

# **ALAMO** INDUSTRIAL **AG96** Rotary Cutter

Published 09/04

Part No. 00761808P

## **PART'S MANUAL**



An Operator's Manual was shipped with the equipment in the Manual Canister. This Operator's Manual is an integral part of the safe operation of this machine and must be maintained with the unit at all times. **READ, UNDERSTAND, and FOLLOW** the Safety and Operation Instructions contained in this manual before operating the equipment. If the Operator's Manual is not with the equipment, contact your dealer or Alamo Industrial (830-372-3551) to obtain a Free copy before operating the equipment.

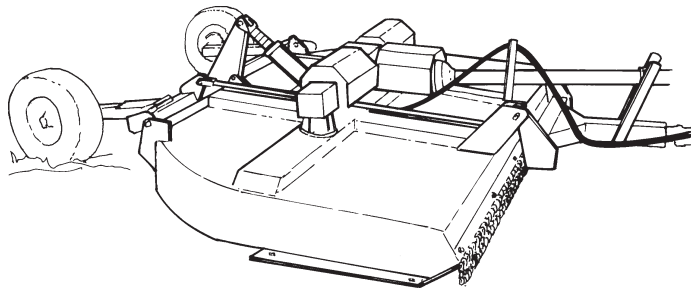

### **ATENCIÓN!**

LEA EL INSTRUCTIVO

Si No Lee Ingles, Pida Ayuda a Alguien  
Que Si Lo Lea Para Que le Traduzca las  
Medidas de Seguridad.

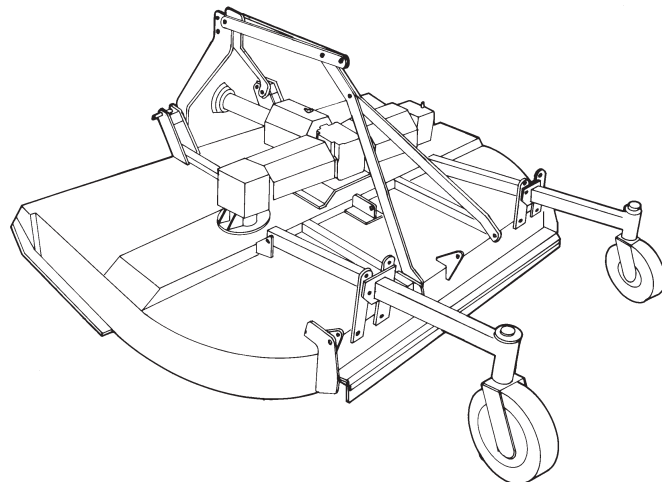

### **Alamo Industrial**

1502 E. Walnut  
Seguin, Texas 78155  
830-372-3551





# TO THE OWNER/OPERATOR/DEALER

All implements with moving parts are potentially hazardous. There is no substitute for a cautious, safe-minded operator who recognizes the potential hazards and follows reasonable safety practices. The manufacturer has designed this implement to be used with all its safety equipment properly attached to minimize the chance of accidents.

**BEFORE YOU START!!** Read the safety messages on the implement and shown in your manual.  
Observe the rules of safety and common sense!



# DANGER

FAILING TO FOLLOW SAFETY MESSAGES AND OPERATING INSTRUCTIONS CAN CAUSE SERIOUS BODILY INJURY OR EVEN DEATH TO OPERATOR AND OTHERS IN THE AREA.

<p>1.</p>	<p>2. NO RIDERS, NO CHILDREN OPERATORS</p>	<p>3. USE SAFETY SHOES, HARD HAT, SAFETY GLASSES, SEAT BELTS, &amp; ROPS</p>	<p>4. BLOCK UP SECURELY BEFORE WORKING UNDER.</p>
-----------	--	--	---

- Study and understand Operator's Manuals, Safety Signs, and Instructional Decals for tractor & flail mower to prevent misuse, abuse, & accidents. Practice before operating mower in a confined area or near passersby.
  - Learn how to stop engine suddenly in an emergency. Be alert for passersby and especially children.
- Allow no children on or near implement or tractor. Allow no riders on tractor or implement. Falling off can cause serious injury or death from being runover by tractor or mower or contact with Flail Mower Blades.
- Operate only with tractor having Roll-Over Protective Structure (ROPS) and with seatbelt fastened securely and snugly to prevent injury and possible death from falling off or tractor overturn. Personal Protective Equipment such as Hard Hat, Safety Glasses, Safety Shoes, and Ear Plugs are recommended.
- Block up or support raised machine and all lifted components securely before putting hands or feet under or working underneath any lifted component to prevent crushing injury or death from sudden dropping or inadvertent operation of controls. Make certain that area is clear before lowering or folding.
- Before transporting, put Lift Lever in detent or full-lift position. Install Transport Safety Devices securely on folding implements. Slow down when turning and on hillsides.
  - Install \*\*Restrictor in folding circuit to slow down lowering and unfolding if action is faster than is desirable.
- Make certain that SMV sign, Warning Lights, and Reflectors are clearly visible. Follow local traffic codes.
- Never operate with Flail Mower or Folding Section raised if passersby, bystanders or traffic are in the area to reduce possibility of injury or death from objects thrown by Blades under Shields or implement structure.
- Before dismounting, secure flail mower in transport position or lower to ground.
  - Put tractor in park or set brake, disengage PTO, stop engine, remove key, and wait until noise of rotation has ceased to prevent entanglement in rotating parts which may cause injury or death.
  - Never mount or dismount a moving vehicle. Crushing from runover may cause injury or death.

<p>5. TRANSPORT SAFELY, LOCK UP.</p>	<p>6. USE SMV, LIGHTS, &amp; REFLECTORS.</p>	<p>7. DO NOT OPERATE WITH MOWER OR WING RAISED.</p>	<p>8. DO NOT MOUNT OR DISMOUNT WHILE MOVING.</p>
--------------------------------------	--	---	--

Read and understand the complete Warranty Statement found in this Manual. Fill out the Warranty Registration Form in full and return it within 30 Days. Make certain the Serial Number of the Machine is recorded on the Warranty Card and on the Warranty Form that you retain. The use of "will-fit" parts will void your warranty and can cause catastrophic failure with possible injury or death.

WARRANTY INFORMATION

002369



# **PARTS SECTION**

# PARTS ORDERING GUIDE

The following instructions are offered to help eliminate needless delay and error in processing purchase orders for the equipment in this section.

1. The Parts Section is prepared in logical sequence and grouping of parts that belong to the basic machine featured in this manual. Part Numbers and Descriptions are given to help locate the parts and quantities required.
2. The Purchase Order must include the name and address of the person or organization ordering the parts, who should be charged, and if possible, the serial number of the machine for which the parts are ordered.
3. The Purchase Order must clearly list the quantity of each part, the complete and correct part number, and the basic name of the part.
4. The Manufacturer reserves the right to substitute parts where applicable.
5. Some parts are unlisted items which are special production items not normally stocked and are subject to special handling. Request a quotation for such parts before sending a Purchase Order.
6. The Manufacturer reserves the right to change prices without prior notice.

NOTE: Please refer to The Safety Section in the front of this Manual for the proper Part Number when ordering Replacement Safety Decals.

NOTE: Please note that the appearance of some parts may vary from the art or photographs shown in this manual.



For maximum safety and to guarantee optimum product reliability, always use genuine Alamo Parts. The use of inferior replacement parts may cause premature or catastrophic failure which could result in serious injury or death. Direct any questions regarding parts to:



Alamo Industrial  
1502 E. Walnut  
Seguin, Texas 78155  
830-379-1480

# PART NAME INDEX

A-FRAME ASSEMBLY - CAT II & III.....	4
AXLE ASSEMBLY .....	7
AXLE ASSEMBLY (SEMI MOUNT & HYD OFFSET MODELS).....	65
BLADE PAN ASSEMBLIES (OFFSET MODEL) .....	57
BLADE PAN ASSEMBLY .....	25
CASTER ASSEMBLY (AXLE) - FOAM FILLED .....	66
CASTER ASSEMBLY - LIFT TYPE.....	11
CHAIN GUARD ASSEMBLY - FRONT .....	38
CHAINGUARD ASSEMBLY - REAR.....	39
CONTROL ROD ASSEMBLY .....	6
CONTROL ROD ASSEMBLY - CV DRIVELINE OPTION .....	47
CYLINDER, HYDRAULIC (OPTIONAL) .....	61, 62
DEFLECTOR ASSEMBLY - FRONT .....	36
DEFLECTOR ASSEMBLY - REAR .....	37
DRIVELINE - LIFT TYPE 1000 RPM .....	16
DRIVELINE - LIFT TYPE 540 RPM .....	13
DRIVELINE - PULL TYPE 1000 RPM.....	18
DRIVELINE - PULL TYPE 540 & 1000 RPM .....	19
DRIVELINE - PULL TYPE 540 RPM.....	17
DRIVELINE ASSEMBLY - CV .....	40, 48
DRIVELINE ASSEMBLY - LIFT TYPE (540 & 1000 RPM).....	14
DRIVELINE COUPLER (OFFSET MODEL).....	56
DRIVELINE COUPLER - OPTIONAL TYPE .....	35
DRIVELINE COUPLER S/N 01604 & BELOW Rev 09-04.....	32
DRIVELINE COUPLER S/N 01605 (09-04) to S/N 01645 (01-05) .....	33
DRIVELINE COUPLER S/N 01646 (01-05) to CURRENT.....	34
GEARBOX - CENTER 540 RPM (OFFSET MODEL) .....	52
GEARBOX ASSEMBLY - DIVIDER 1000 RPM .....	29
GEARBOX ASSEMBLY - DIVIDER 540 RPM .....	28
GEARBOX ASSEMBLY - OUTER.....	30
GEARBOX ASSEMBLY - SIDE (OFFSET MODEL) .....	50
GEARBOX MOUNT PLATE .....	27
GEARBOX MOUNTING (OFFSET MODEL).....	54
HYDRAULIC OFFSET .....	60
JACKSHAFT ASSEMBLY - CV DRIVELINE .....	42
JACKSHAFT ASSEMBLY - PULL TYPE.....	22, 23
JACKSHAFT SUPPORT - PULL TYPE.....	24
JACKSHAFT SUPPORT - PULL TYPE (OFFSET MODEL).....	58
MOWER SUPPORT ASSEMBLY (OFFSET MODEL) .....	59
OFFSET ADAPTER, THREE-POINT (OPTIONAL).....	63
SHIELDS.....	26
SKID SHOE ASSEMBLY .....	46
SLIP CLUTCH ASSEMBLY .....	20, 21
SPRING SHOCK ASSEMBLY .....	10
TAILWHEEL ASSEMBLY - LIFT TYPE .....	12
TIRE & WHEEL OPTIONS - PULL TYPE .....	67
TONGUE & JACKSHAFT ASSY - CV DRIVELINE OPTION.....	44
TONGUE ASSEMBLY .....	5
TONGUE ASSEMBLY (OFFSET MODEL).....	49
WHEEL ASSEMBLY.....	8
WHEEL HUB ASSEMBLY .....	9

# A-FRAME ASSEMBLY - CAT II & III

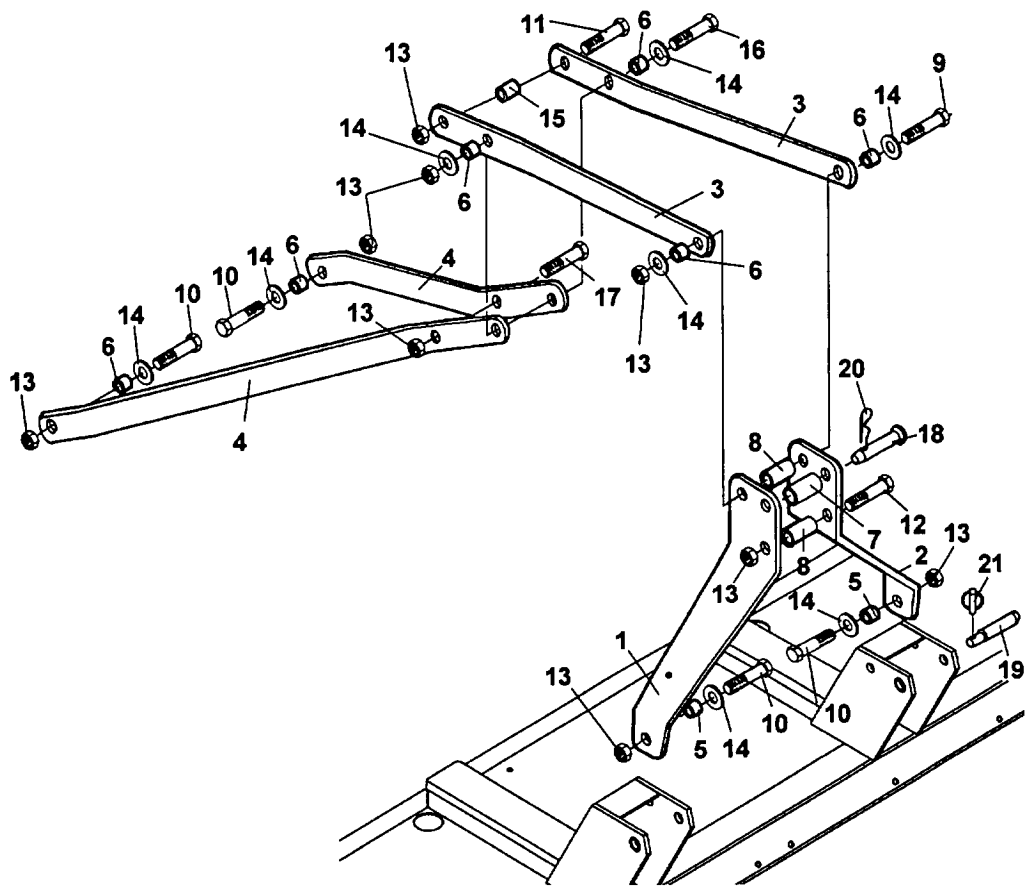

ITEM	PART NO.	QTY.	DESCRIPTION
1	0758550010	1	A-FRAME - ( RH )
2	0758550020	1	A-FRAME - ( LH )
3	00761669	2	BRACE
4	00771403	2	SUPPORT BRACE
5	0758550070	6	BUSHING
6	701023R	1	BUSHING
8	0758550031	2	BUSHING
9	00009500	1	BOLT
10	00037100	5	BOLT
11	02959391	1	BOLT
12	7AH5161436	2	BOLT
13	00037200	9	NUT
14	5312316	8	WASHER
15	00761267	1	BUSHING
16	00007800	2	BOLT
17	5JRC16140	1	NUT
18	3730110	1	TOP LINK PIN
19	69141	2	LOWER HITCH PIN
21	2196	3	CLIP

# TONGUE ASSEMBLY

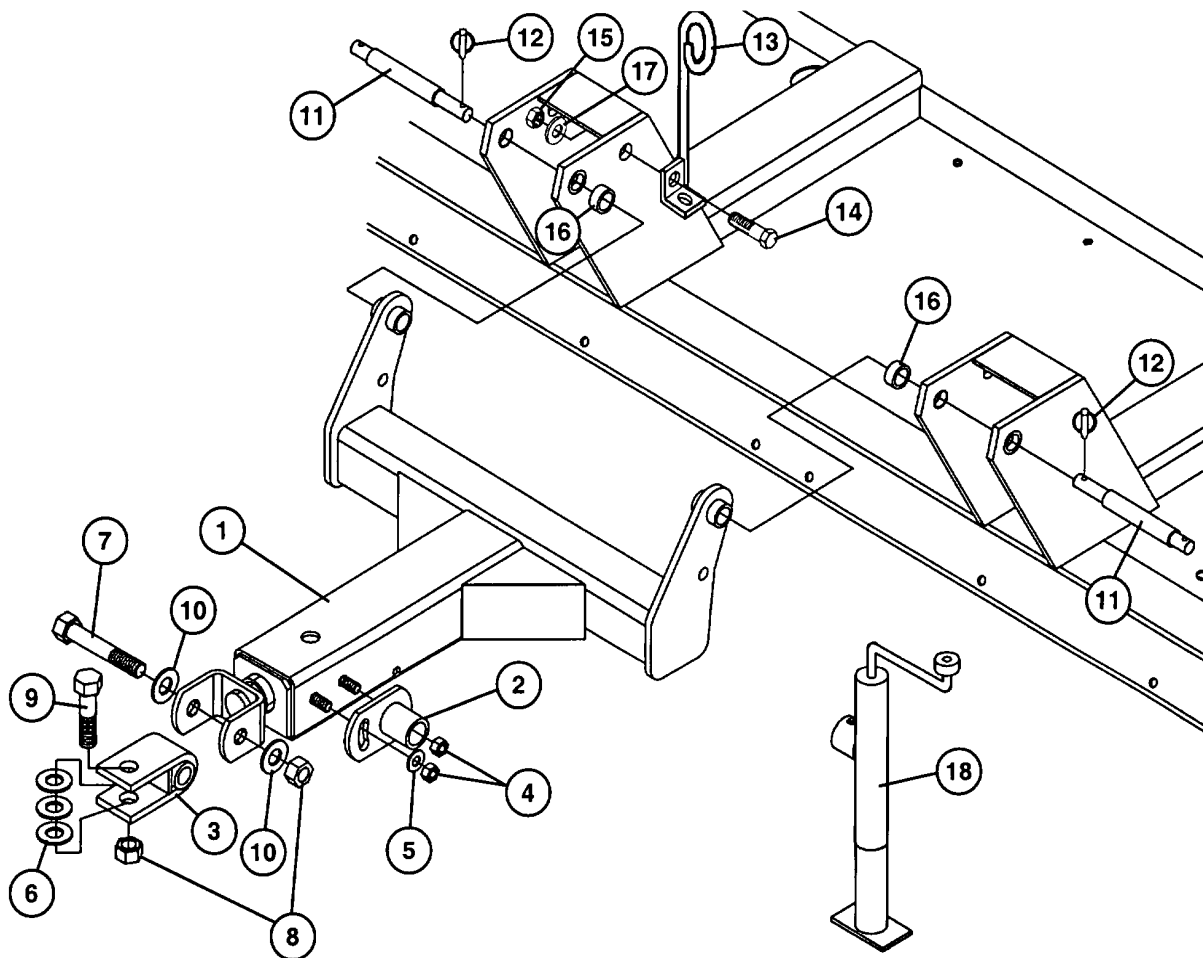

ITEM	PART NO.	QTY.	DESCRIPTION
1	00761272	1	TONGUE WLD'MT
2	00760941	1	JACK TUBE MOUNT WLD'MT
3	00748807	1	CLEVIS WLD'MT
4	00695100	2	LOCKNUT
5	00001400	1	FLATWASHER
6	00759275	3	HITCH CLEVIS WASHER
7	00755305	1	BOLT
8	02030300	2	LOCKNUT
9	02712500	1	BOLT
10	00757478	2	SPRING WASHER
11	69141	2	HITCH PIN
12	2196	2	CLIP
13	8343	1	HOSE HOLDER
14	00748823	1	BOLT
15	00001800	1	LOCKNUT
16	02958686	2	PIVOT BUSHING - SHORT
17	00002700	1	FLATWASHER
18	00772391	1	PARKING JACK

# CONTROL ROD ASSEMBLY

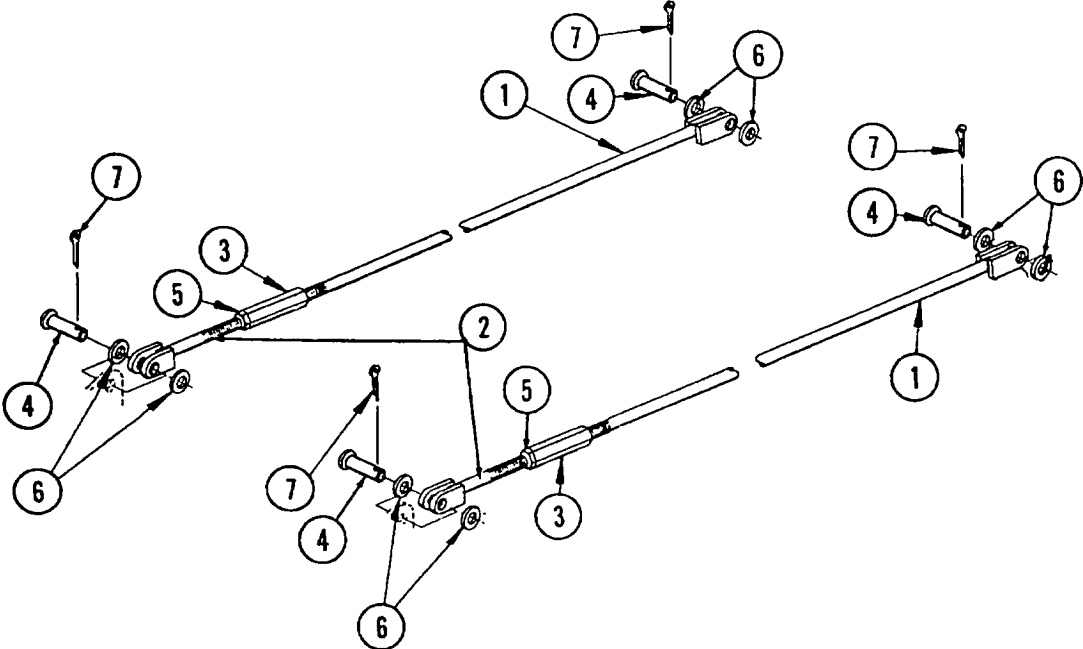

ITEM	PART NO.	QTY.	DESCRIPTION
	<b>00773133</b>	-	<b>CONTROL ROD ASY.</b>
1	00773132	2	CONTROL ROD WLD'MT, L.H. THDS
2	00758643	2	CONTROL ROD WLD'MT, R.H. THDS
3	00778159	2	ADJUSTING NUT WLD'MT 9"
4	651102	4	CONTROL ROD PIN
5	5C1490	2	JAM NUT
6	15B1200	8	WASHER
7	00755153	8	COTTER PIN

# AXLE ASSEMBLY

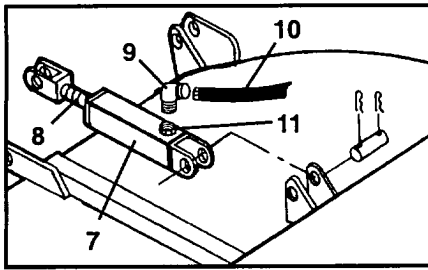

Hydraulic Option

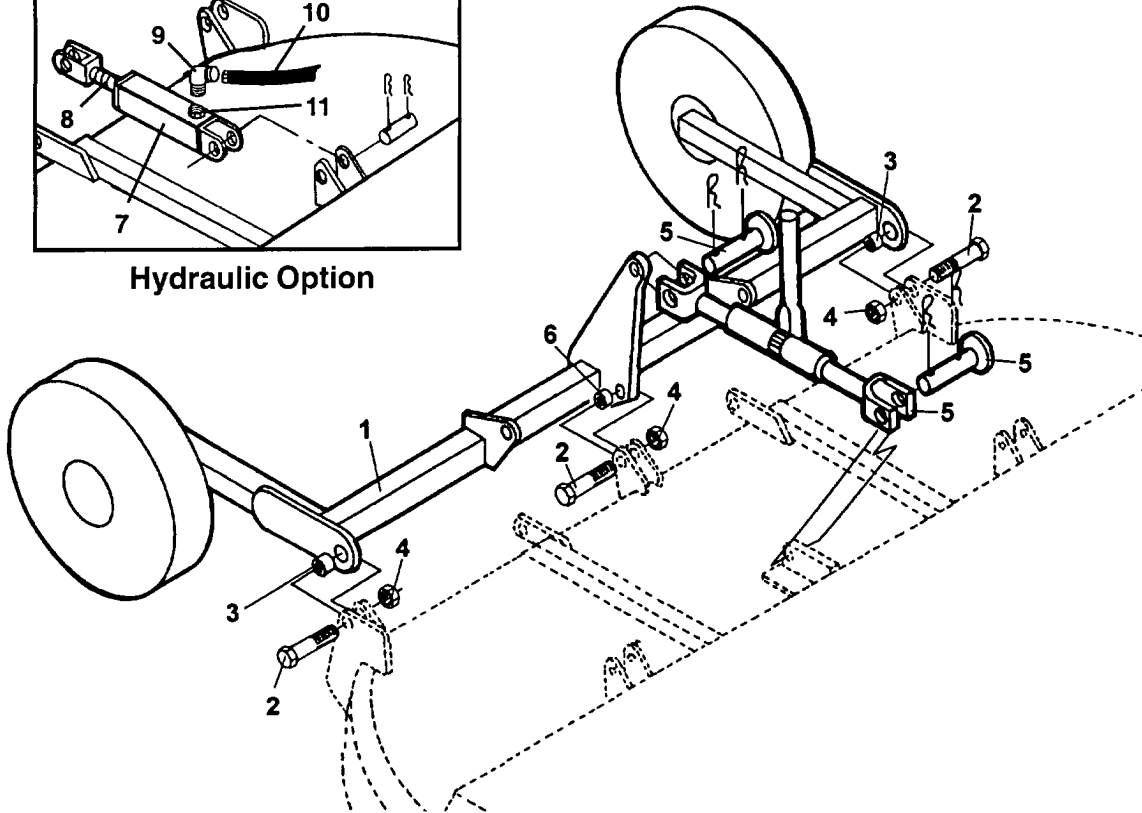

ITEM	PART NO.	QTY.	DESCRIPTION
1	00761271	1	AXLE WLD'MT
2	00007800	3	BOLT
3	00762802	2	BUSHING
4	00037200	3	LOCKNUT
5	00554600	1	RATCHET JACK ASY.
6	8327	1	LEVEL ROD BUSHING
7	8727A	1	HYDRAULIC CYLINDER
8	00755234	1	CONTROL SPACER
9	94514	1	ELBOW SWIVEL
10	651132	1	HOSE
11	00768343	1	HYD. ADAPTER

# WHEEL ASSEMBLY

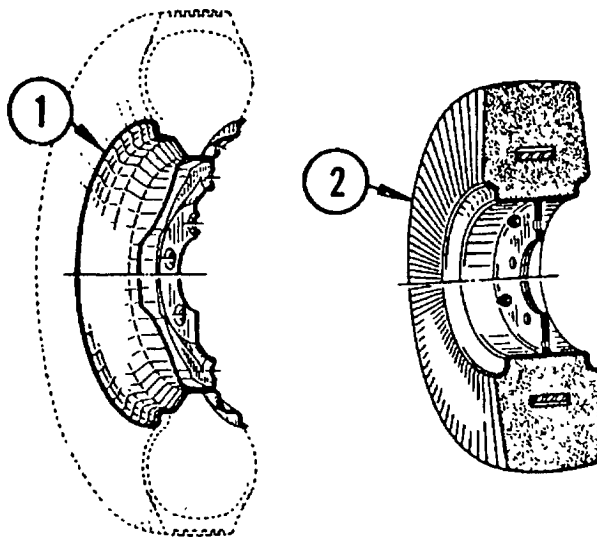

**Wheel Group**  
(Quantities Shown for 1-Cutter, Complete)

ITEM	PART NO.	QTY.	DESCRIPTION
1	00008700	2	WHEEL
2	00025200	2	LAMINATED PUNCTURE-PROOF TIRE & WHEEL ASSEMBLY
	00749700	-	USED 14" AIRPLANE TIRE/WHEEL ( NOT SHOWN )
	00749698	-	IMPLEMENT TIRE/WHEEL ( NOT SHOWN )

Wheel Group (Quantities

# WHEEL HUB ASSEMBLY

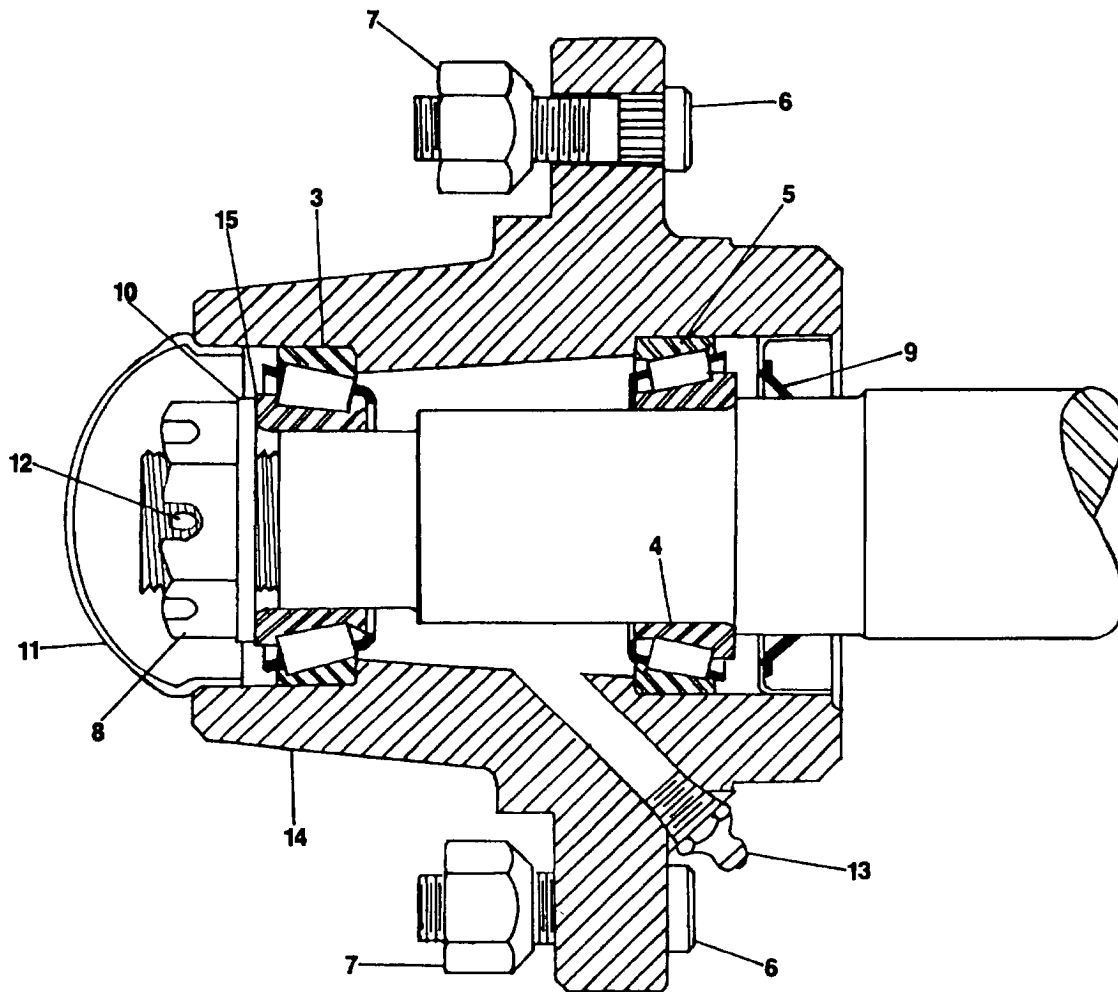

ITEM	PART NO.	QTY.	DESCRIPTION
3	00756576	1	BEARING CUP(OUTSIDE)
4	00750434	1	BEARING CONE(INSIDE)
5	00756577	1	BEARING CUP(INSIDE)
6	00756488	5	STUD BOLT
7	00750614	5	NUT
8	00756490	1	NUT WHEEL HUB
9	02957044	1	OIL SEAL
10	00756493	1	WASHER
11	00756492	1	DUST CAP
12	00000400	1	COTTER PIN
13	00003500	1	GREASE FITTING
14	00756489	1	WHEEL HUB W/CUPS
15	0371242102	1	BEARING CONE(OUTSIDE)

# SPRING SHOCK ASSEMBLY

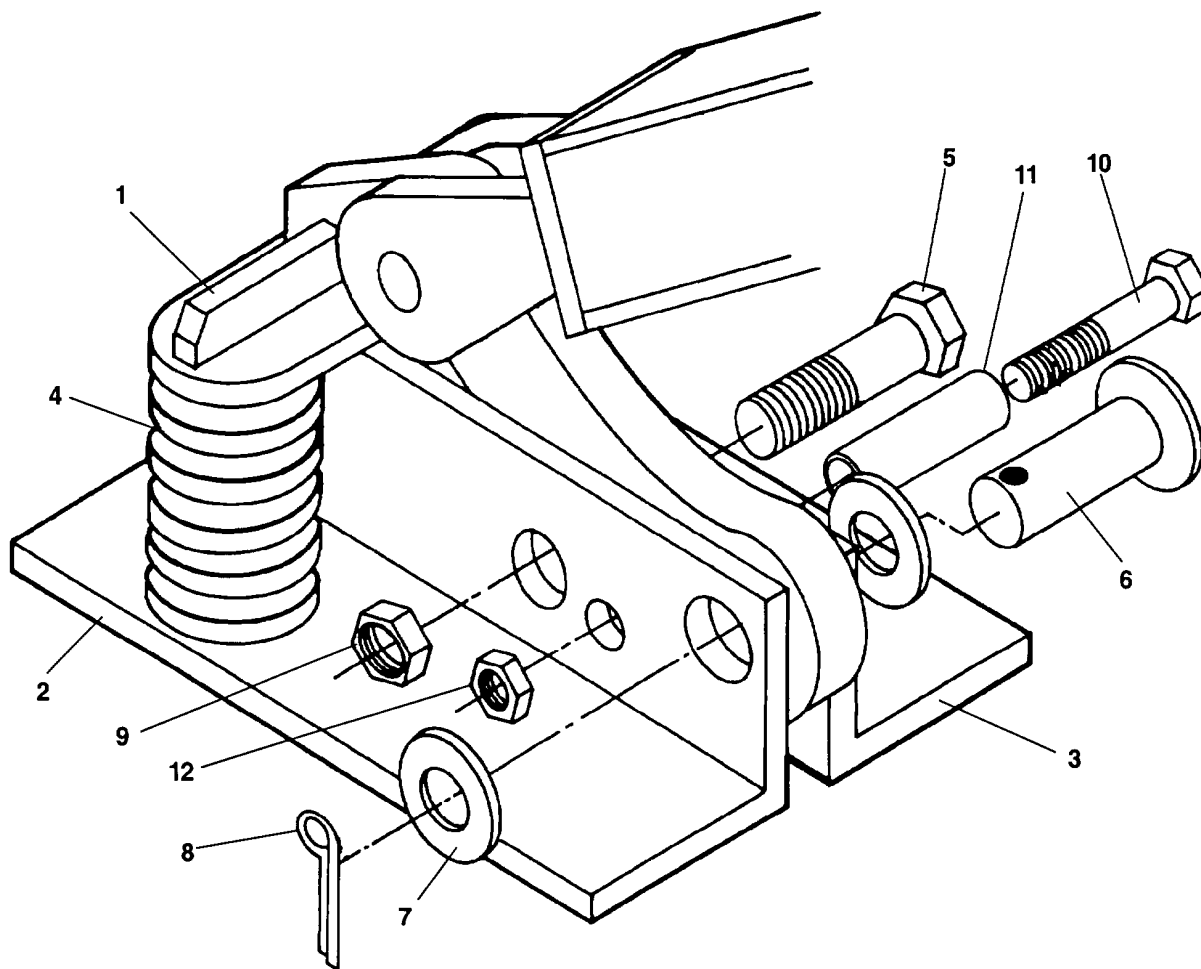

ITEM	PART NO.	QTY.	DESCRIPTION
	<b>00759191</b>	-	<b>SPRING SHOCK ASSEMBLY</b>
1	00759190	1	SPRING SHOCK WLD'MT
2	00759189	1	ANGLE BRACKET WLD'MT - LH
3	00759188	1	ANGLE BRACKET WLD'MT - RH
4	371063A	2	SPRING
5	02782100	1	BOLT
6	8354	1	PIN
7	02822500	1	FLAT WASHER
8	00606000	1	COTTER PIN
9	02030300	1	LOCKNUT
10	00750952	1	BOLT
11	00761199	1	TUBE SPACER
12	00695100	1	LOCKNUT

# CASTER ASSEMBLY - LIFT TYPE

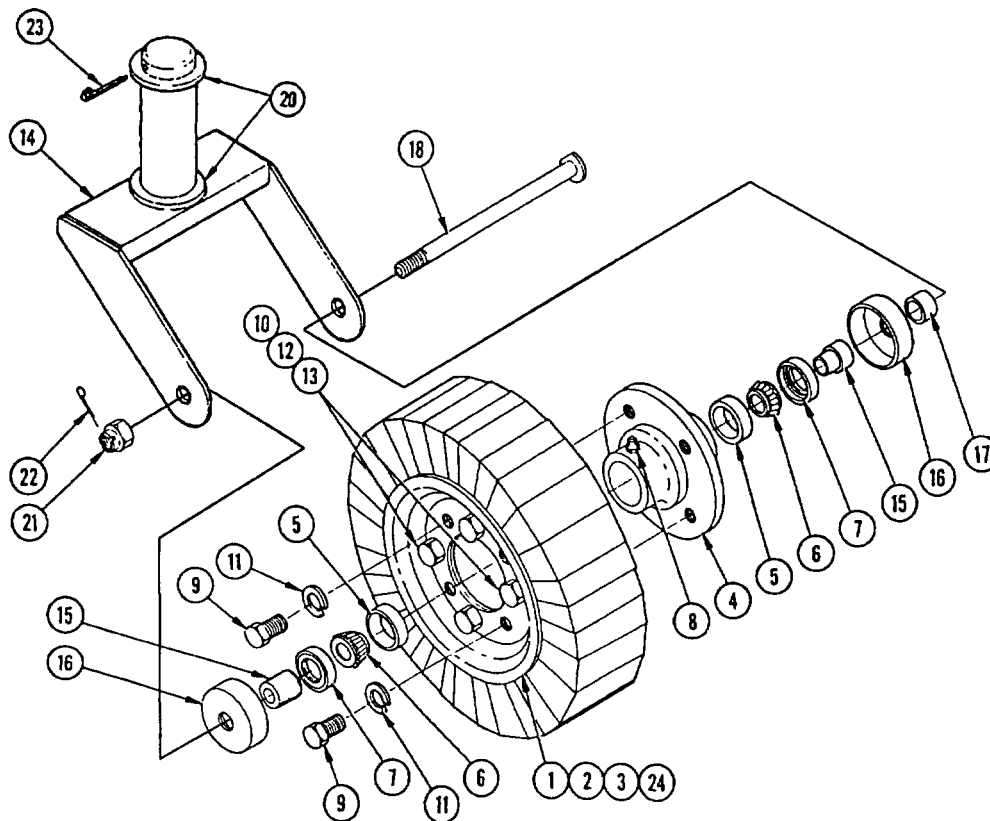

ITEM	PART NO.	QTY.	DESCRIPTION
	<b>00760766</b>	-	<b>CASTER ASSEMBLY</b>
1	373024	1	TIRE & WHEEL ASY.
2	373024A	1	TIRE
3	373024B	1	8" DIA. WHEEL ASY
4	373024D	1	HUB ASY. ( W/ BEARINGS AND SEALS )
5	00750621	2	BEARING CUP
6	373024F	2	BEARING CONE
7	373024E	2	SEAL
8	00752670	1	GREASE FITTING ( THREADED )
	00600000	1	GREASE FITTING ( DRIVE IN )
9	7A8208	4	BOLT
10	7A6166	4	BOLT
11	00001300	4	LOCKWASHER
12	00012101	4	LOCKWASHER
13	00013901	4	NUT
14	0585020210	1	CASTER FORK WLD'MT
15	37302C2C	2	BUSHING
16	37302D2B	2	DUST CAP
17	511016	2	SPACER BUSHING
18	37302D2A	1	SPINDLE BOLT
19	15B1200	1	WASHER
20	15B2400	2	WASHER
21	5E12160	1	CASTLE NUT
22	00026200	1	COTTER PIN
23	00758899	1	COTTER PIN
24	373024H	1(REF)	TIRE AND WHEEL ASY. ( BOLTED ASY. ONLY - LESS HUB )

## TAILWHEEL ASSEMBLY - LIFT TYPE

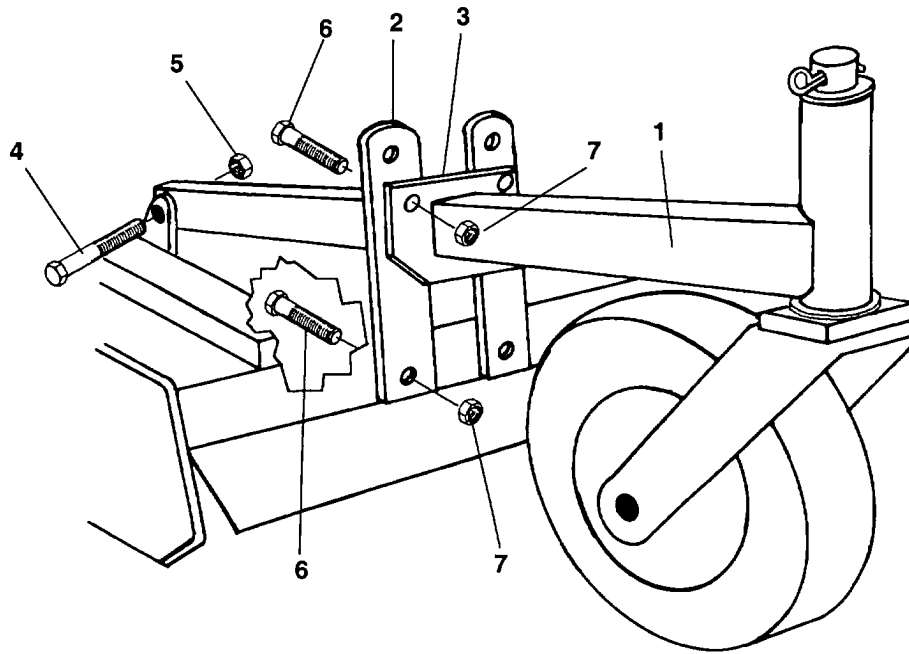

ITEM	PART NO.	QTY.	DESCRIPTION
1	00761466	2	TAILWHEEL BEAM WLD'MT
2	4744	2	BEAM SUPPORT WLD'MT
3	702302R	2	BRACKET
4	00750311	2	BOLT
5	00695100	2	LOCKNUT
6	00748823	8	BOLT
7	00001800	8	LOCKNUT

# DRIVELINE - LIFT TYPE 540 RPM

Order replacement parts from this page if the profile of your driveline is triangle shaped.

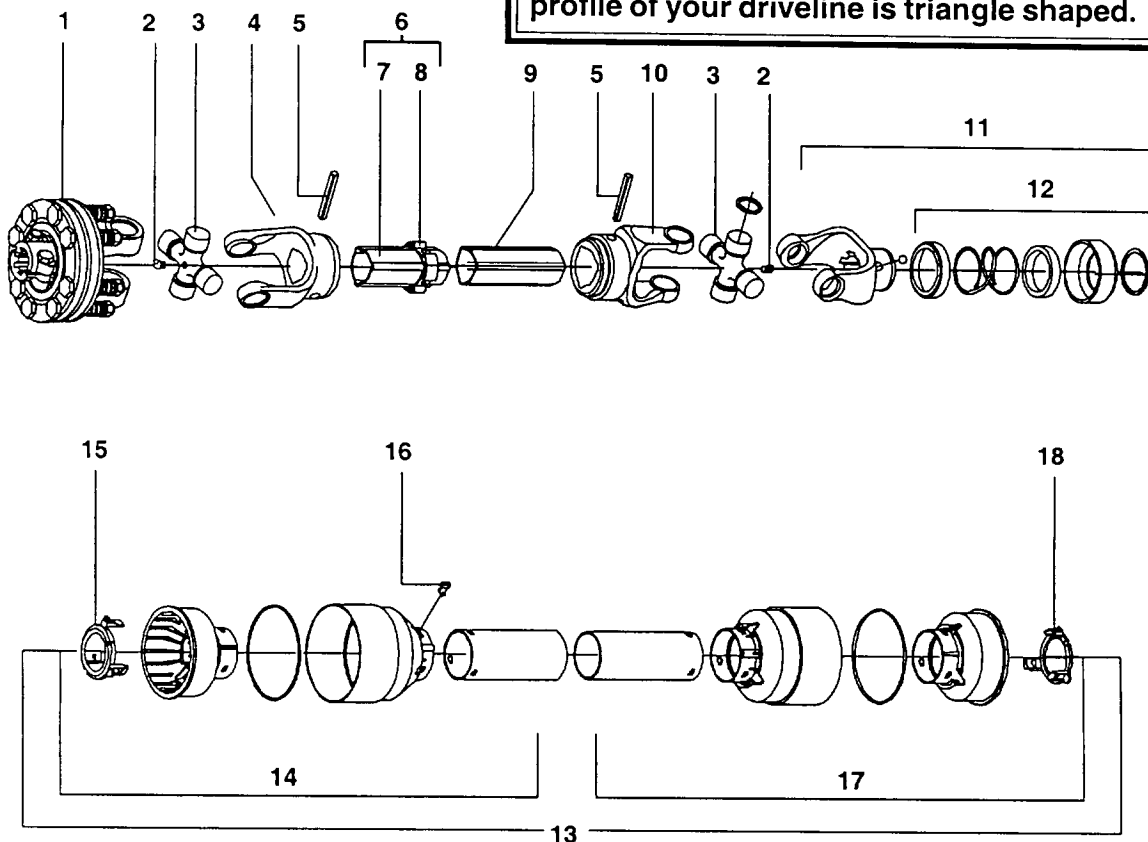

ITEM	PART NO.	QTY.	DESCRIPTION
	<b>00761322</b>	-	<b>COMPLETE DRIVELINE W/ SHIELD</b>
	<b>00761324</b>	-	<b>OUTER HALF DRIVELINE W/ SHIELD</b>
	<b>00754376</b>	-	<b>INNER HALF DRIVELINE W/ SHIELD</b>
1	00756075	1	SLIP CLUTCH
2	00754335	2	GREASE FITTING
3	00752896	2	CROSS & BEARING KIT
4	00754154	1	OUTER YOKE
5	00754167	2	ROLL PIN
6	00762726	1	OUTER TUBE
7	00756004	1	DECAL - DANGER
8	00772529	1	BUSHING W/ GREASE FITTING
9	00762735	1	INNER TUBE
10	00754153	1	INNER YOKE
11	00752883	1	YOKE SLIDE COLLAR ( COMPLETE )
12	00757144	1	COLLAR KIT
13	00754379	1	SHIELD KIT ( COMPLETE )
14	00754377	1	OUTER SHIELD KIT
15	00754332	1	LOCKING COLLAR FOR OUTER SHIELD
16	00754330	6	BOLT
17	00754378	1	INNER SHIELD KIT
18	00754331	1	LOCKING COLLAR FOR INNER SHIELD

# DRIVELINE ASSEMBLY - LIFT TYPE (540 & 1000 RPM)

Order replacement parts from this page if the profile of your driveline is lemon shaped.

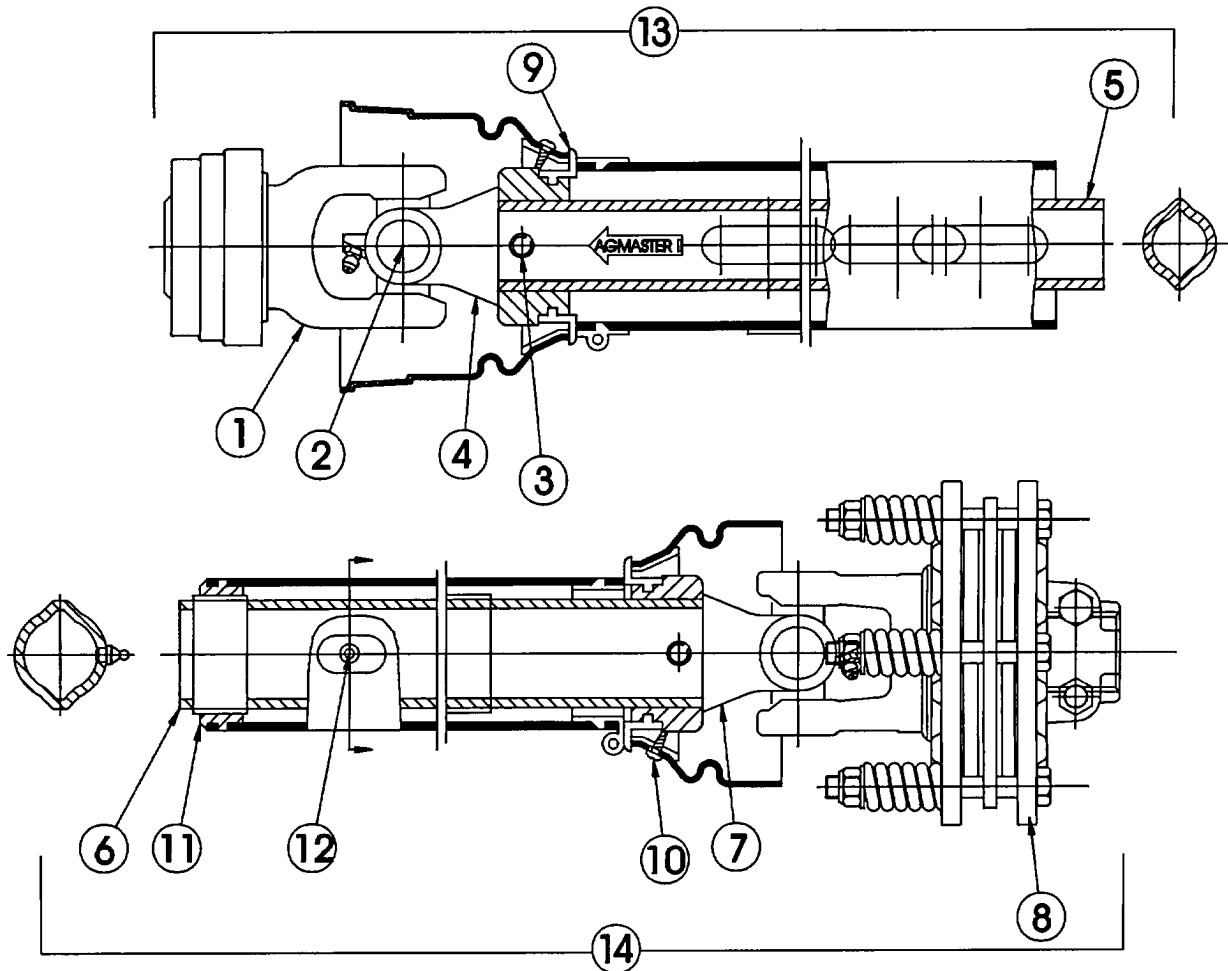

## DRIVELINE ASSEMBLY - LIFT TYPE (540 & 1000 RPM)

ITEM	PART NO.	QTY.	DESCRIPTION
	<b>00775422</b>	-	<b>DRIVELINE ASY.</b>
1	00775353	1	YOKE
2	W279R	2	CROSS & BEARING KIT
3	8384	2	SPRING PIN
4	00775317	1	INBOARD YOKE
5	0921000332	1	INNER PROFILE
6	00775378	1	PROFILE & SLEEVE WLD'MT
7	00775318	1	INBOARD YOKE
8	00775419	1	FRICTION CLUTCH
9	8393	2	BEARING RING
10	4797	2	SCREW
11	8974	1	SUPPORT BEARING
12	1416601	1	ZERK
13	00775427	1	OUTER SHIELD HALF
14	00775428	1	INNER SHIELD HALF
15	00767954	1	YOKE QD KIT
16	8371	1	QD FLANGE KIT

# DRIVELINE - LIFT TYPE 1000 RPM

Order replacement parts from this page if the profile of your driveline is triangle shaped.

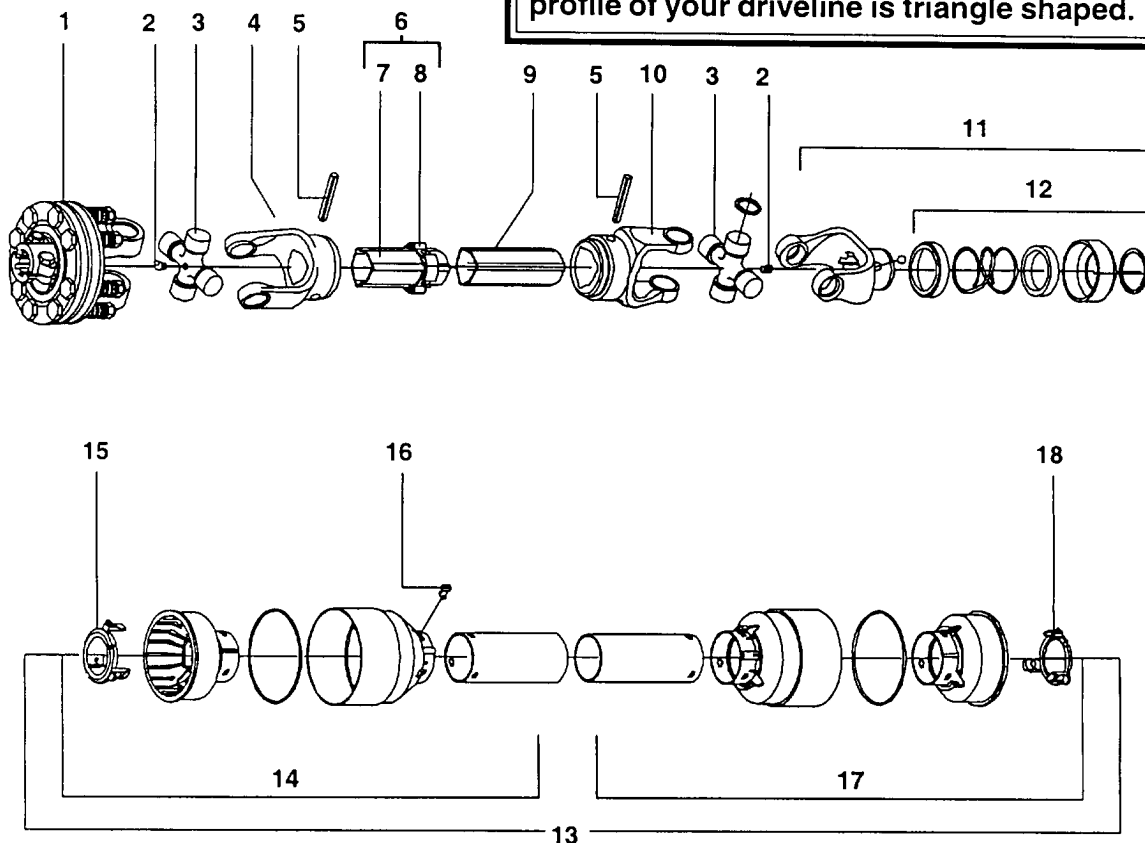

ITEM	PART NO.	QTY.	DESCRIPTION
	<b>00761325</b>	-	<b>COMPLETE DRIVELINE W/ SHIELD</b>
	<b>00761324</b>	-	<b>OUTER HALF DRIVELINE W/ SHIELD</b>
	<b>00761326</b>	-	<b>INNER HALF DRIVELINE W/ SHIELD</b>
1	00756075	1	SLIP CLUTCH
2	00754335	2	GREASE FITTING
3	00752896	2	CROSS & BEARING KIT
4	00754154	1	OUTER YOKE
5	00754167	2	ROLL PIN
6	00762726	1	OUTER TUBE
7	00756004	1	DECAL - DANGER
8	00772529	1	BUSHING W/ GREASE FITTING
9	00762735	1	INNER TUBE
10	00754153	1	INNER YOKE
11	00760002	1	YOKE SLIDE COLLAR ( COMPLETE )
12	00757144	1	COLLAR KIT
13	00754379	1	SHIELD KIT ( COMPLETE )
14	00754377	1	OUTER SHIELD KIT
15	00754332	1	LOCKING COLLAR FOR OUTER SHIELD
16	00754330	6	BOLT
17	00754378	1	INNER SHIELD KIT
18	00754331	1	LOCKING COLLAR FOR INNER SHIELD

# DRIVELINE - PULL TYPE 540 RPM

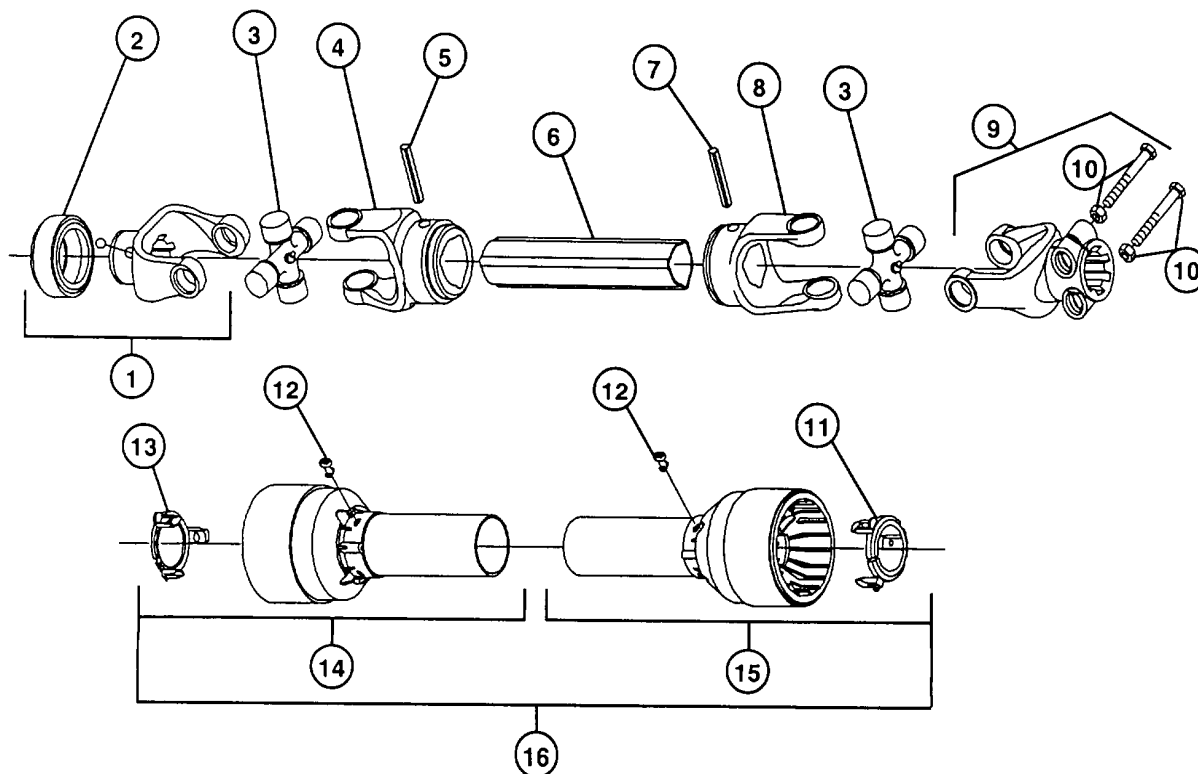

Order replacement parts from this page if the profile of your driveline is triangle shaped.

NOTE: Clamp Yoke will interchange with Collar Yoke.

ITEM	PART NO.	QTY.	DESCRIPTION
	<b>00760898A</b>	-	<b>MAIN DRIVELINE 540 RPM, EQ ANGLE</b>
1	00752883	1	COMPLETE COLLAR YOKE
2	00757144	1	COLLAR KIT
3	00752896	2	CROSS & BEARING KIT
4	00772793	1	OUTER YOKE
5	00754167	1	ROLL PIN FOR OUTER TUBE
6	00772795	1	INNER TUBE
7	00754167	1	ROLL PIN FOR INNER TUBE
8	00754153	1	INNER YOKE
9	00772530	1	COMPLETE CLAMP YOKE
10	00772531	2	NUT & BOLT SET
11	00754331	1	RETAINING COLLAR FOR INNER TUBE
12	00754330	6	BOLT
13	00754332	1	RETAINING COLLAR FOR OUTER TUBE
14	00773046	1	OUTER SHIELD
15	00773047	1	INNER SHIELD
16	00772794	1	COMPLETE SHIELD

# DRIVELINE - PULL TYPE 1000 RPM

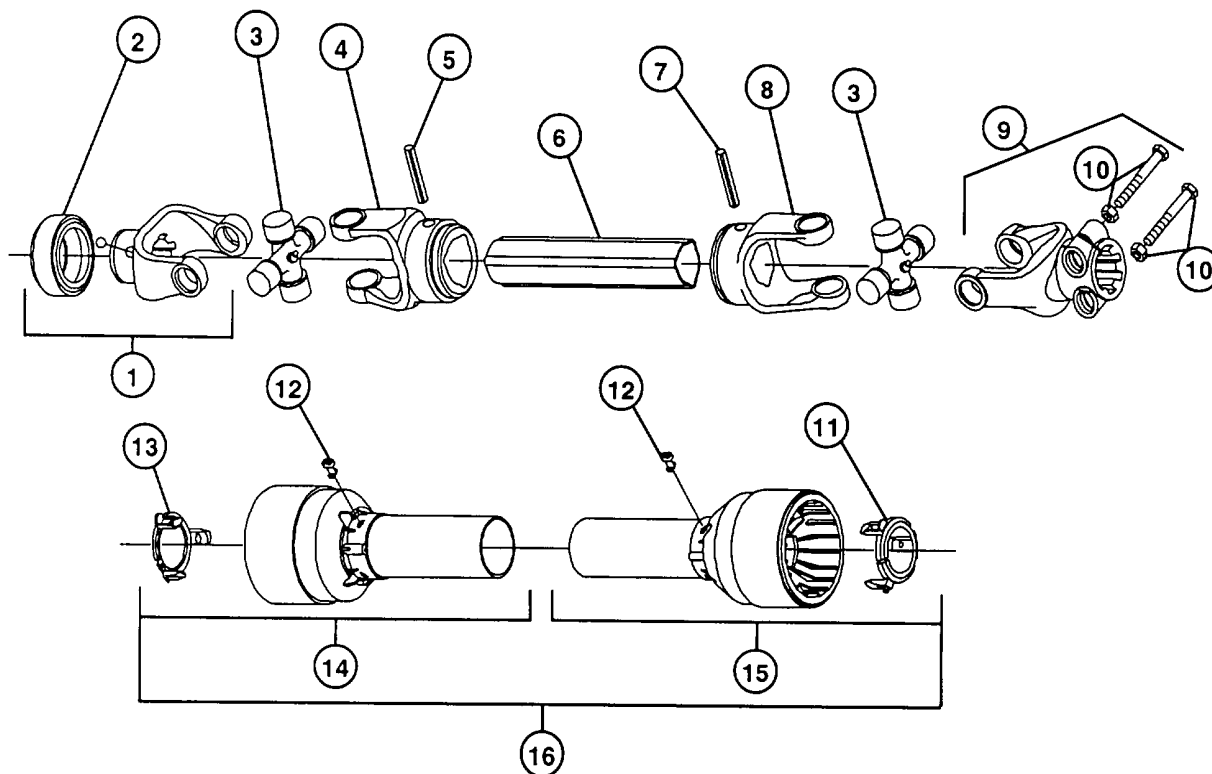

**Order replacement parts from this page if the profile of your driveline is triangle shaped.**

NOTE: Clamp Yoke will interchange with Collar Yoke.

ITEM	PART NO.	QTY.	DESCRIPTION
	<b>00760902A</b>	-	<b>MAIN DRIVELINE 1000 RPM, EQ ANGLE</b>
1	00760002	1	COMPLETE COLLAR YOKE
2	00757144	1	COLLAR KIT
3	00752896	2	CROSS & BEARING KIT
4	00772793	1	OUTER YOKE
5	00754167	1	ROLL PIN FOR OUTER TUBE
6	00772795	1	INNER TUBE
7	00754167	1	ROLL PIN FOR INNER TUBE
8	00754153	1	INNER YOKE
9	00772530	1	COMPLETE CLAMP YOKE
10	00772531	2	NUT & BOLT SET
11	00754331	1	RETAINING COLLAR FOR INNER TUBE
12	00754330	6	BOLT
13	00754332	1	RETAINING COLLAR FOR OUTER TUBE
14	00773046	1	OUTER SHIELD
15	00773047	1	INNER SHIELD
16	00772794	1	COMPLETE SHIELD

# DRIVELINE - PULL TYPE 540 & 1000 RPM

Order replacement parts from this page if the profile of your driveline is lemon shaped.

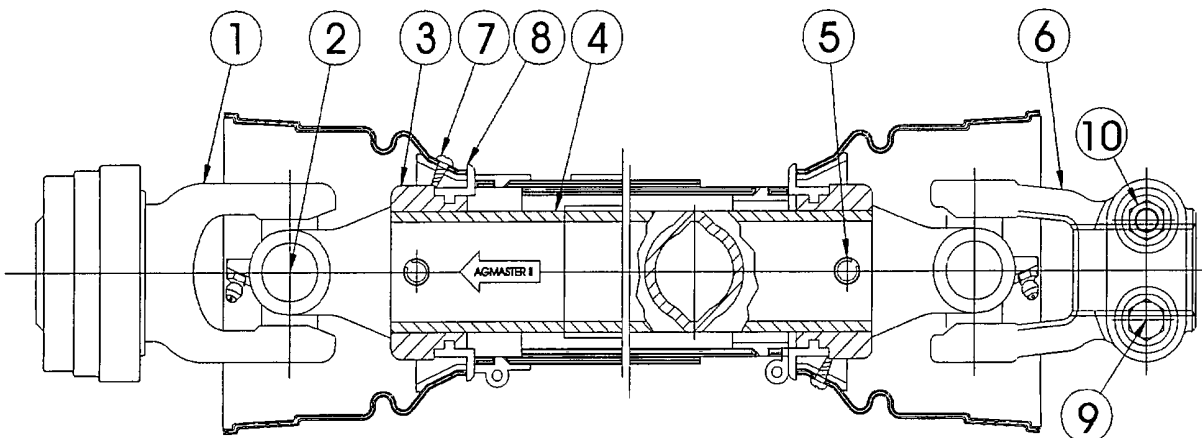

ITEM	PART NO.	QTY.	DESCRIPTION
	<b>00775422</b>	-	<b>DRIVELINE ASY.</b>
1	00775353	1	YOKE
2	W279R	2	CROSS & BEARING KIT
3	8384	2	SPRING PIN
4	00775317	1	INBOARD YOKE
5	0921000332	1	INNER PROFILE
6	00775378	1	PROFILE & SLEEVE WLD'MT
7	00775318	1	INBOARD YOKE
8	00775419	1	FRICTION CLUTCH
9	8393	2	BEARING RING
10	4797	2	SCREW
11	8974	1	SUPPORT BEARING
12	1416601	1	ZERK
13	00775427	1	OUTER SHIELD HALF
14	00775428	1	INNER SHIELD HALF
15	00767954	1	YOKE QD KIT
16	8371	1	QD FLANGE KIT

# SLIP CLUTCH ASSEMBLY

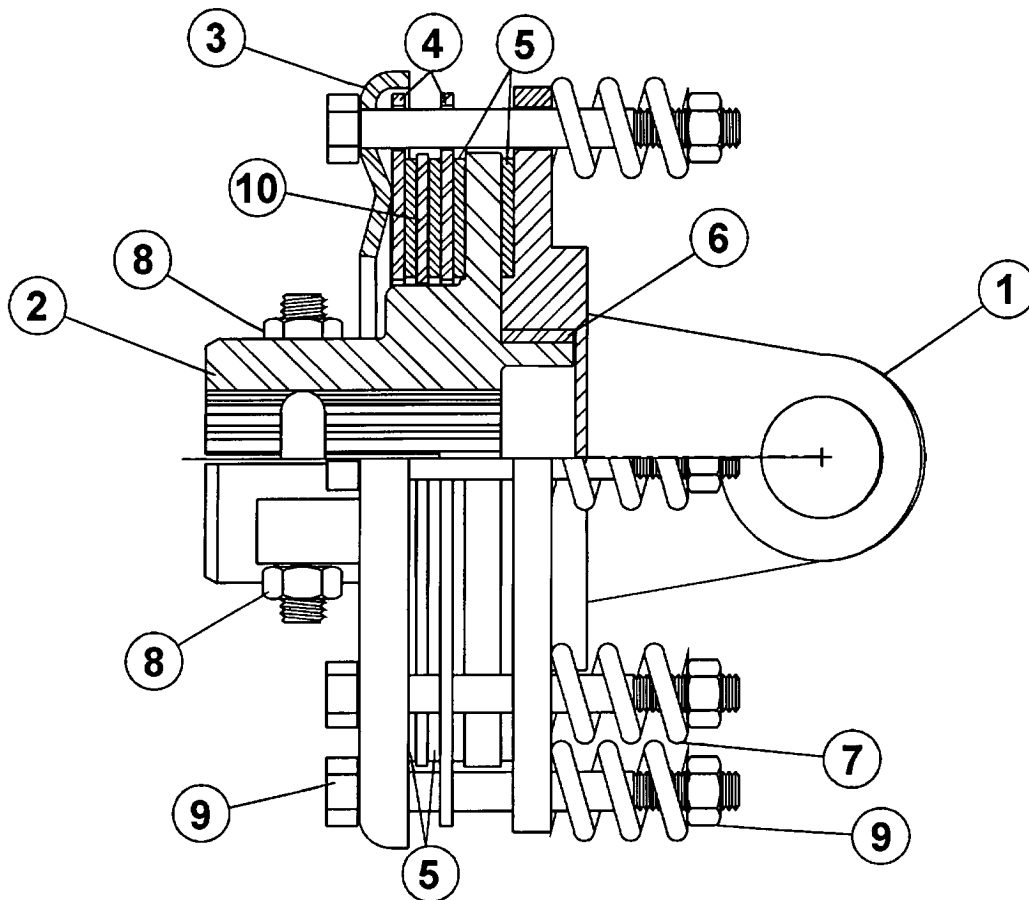

**USED ON DRIVELINES**  
**P/N 00761322, P/N 00761325, P/N 00762045**

ITEM	PART NO.	QTY.	DESCRIPTION
	<b>00756075</b>	<b>1</b>	<b>SLIP CLUTCH ASSEMBLY</b>
1	00754302	1	FLANGE YOKE
2	00755599	1	CLUTCH SUPPORT
3	00766810	1	PRESSURE PLATE
4	00754314	2	PLATE, W/ HOLES
5	00754202	4	LINING RING
6	00754301	1	BUSHING
7	00754303	8	SPRING
8	00755600	2	NUT & BOLT
9	00754199	8	NUT & BOLT
10	00754201	1	INTERMEDIATE PLATE

# SLIP CLUTCH ASSEMBLY

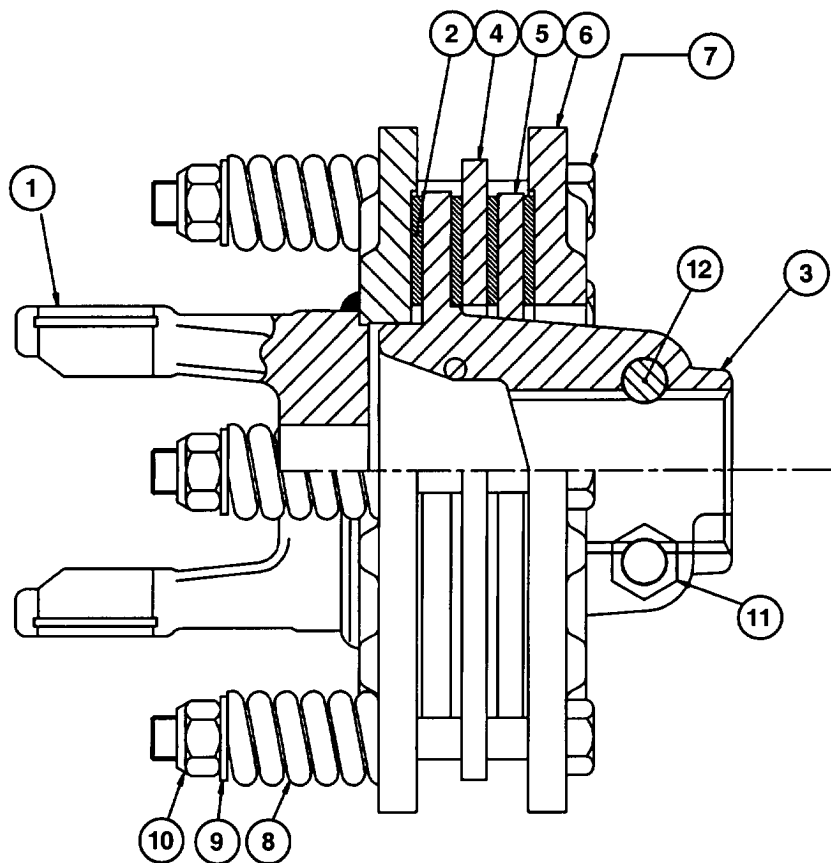

**USED ON DRIVELINES**  
**P/N 00775385, P/N 00775390, P/N 00775397**

ITEM	PART NO.	QTY.	DESCRIPTION
	<b>00775331</b>	-	<b>SLIP CLUTCH</b>
1	00775333	1	FLANGE YOKE
2	8366	4	FRICION DISK
3	00775334	1	HUB
4	00775335	1	DRIVE PLATE
5	00775336	1	DRIVE PLATE
6	00775337	1	THRUST PLATE
7	00775338	6	BOLT
8	00775339	6	COMPRESSION SPRING
9	00754566	6	LOCKWASHER
10	00756164	6	LOCKNUT
11	00775327	2	LOCKNUT
12	00775328	2	BOLT

# JACKSHAFT ASSEMBLY - PULL TYPE

Order replacement parts from this page if the profile of your driveline is triangle shaped.

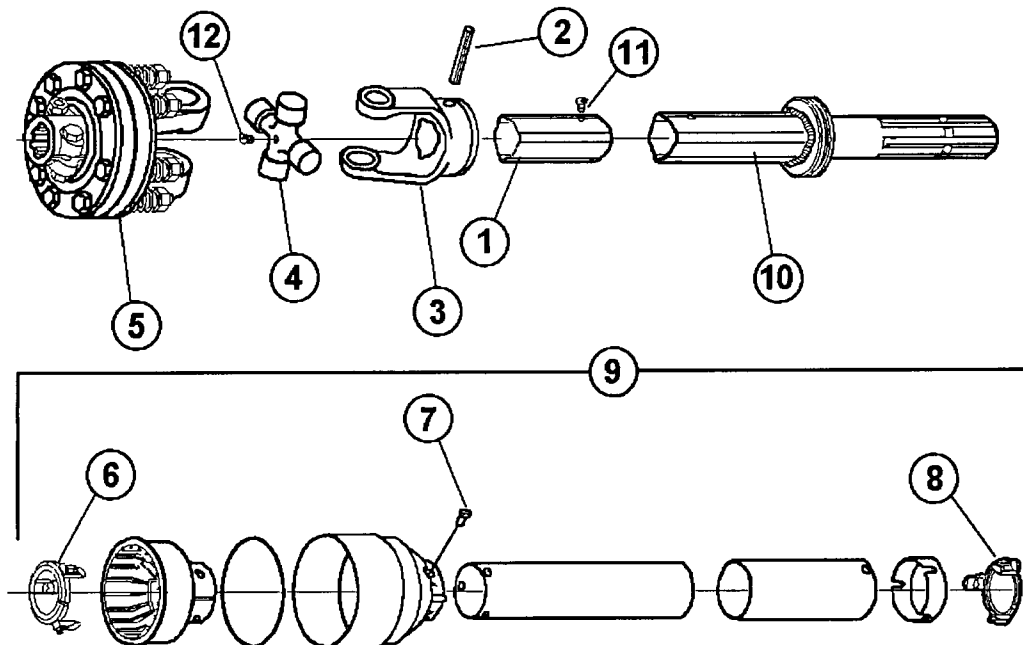

ITEM	PART NO.	QTY.	DESCRIPTION
	<b>00762045</b>	<b>1</b>	<b>JACKSHAFT ASSEMBLY</b>
1	00762730	1	OUTER TUBE TUBE
2	00754167	1	ROLL PIN
3	00754154	1	OUTER YOKE TUBE
4	00752896	1	CROSS & BEARING KIT - SERIES 6
5	00756075	1	SLIP CLUTCH ( W/ SPRING )
6	00754332	1	LOCKING COLLAR ( OUTER TUBE )
7	00754330	6	BOLT
8	00754331	1	LOCKING COLLAR ( INNER TUBE )
9	00762727	1	COMPLETE SHIELD KIT
10	00762729	1	INNER TUBE, 1-3/4" - 20 SPLINE
11	00754335	1	GREASE FITTING
12	00755610	1	GREASE FITTING

# JACKSHAFT ASSEMBLY - PULL TYPE

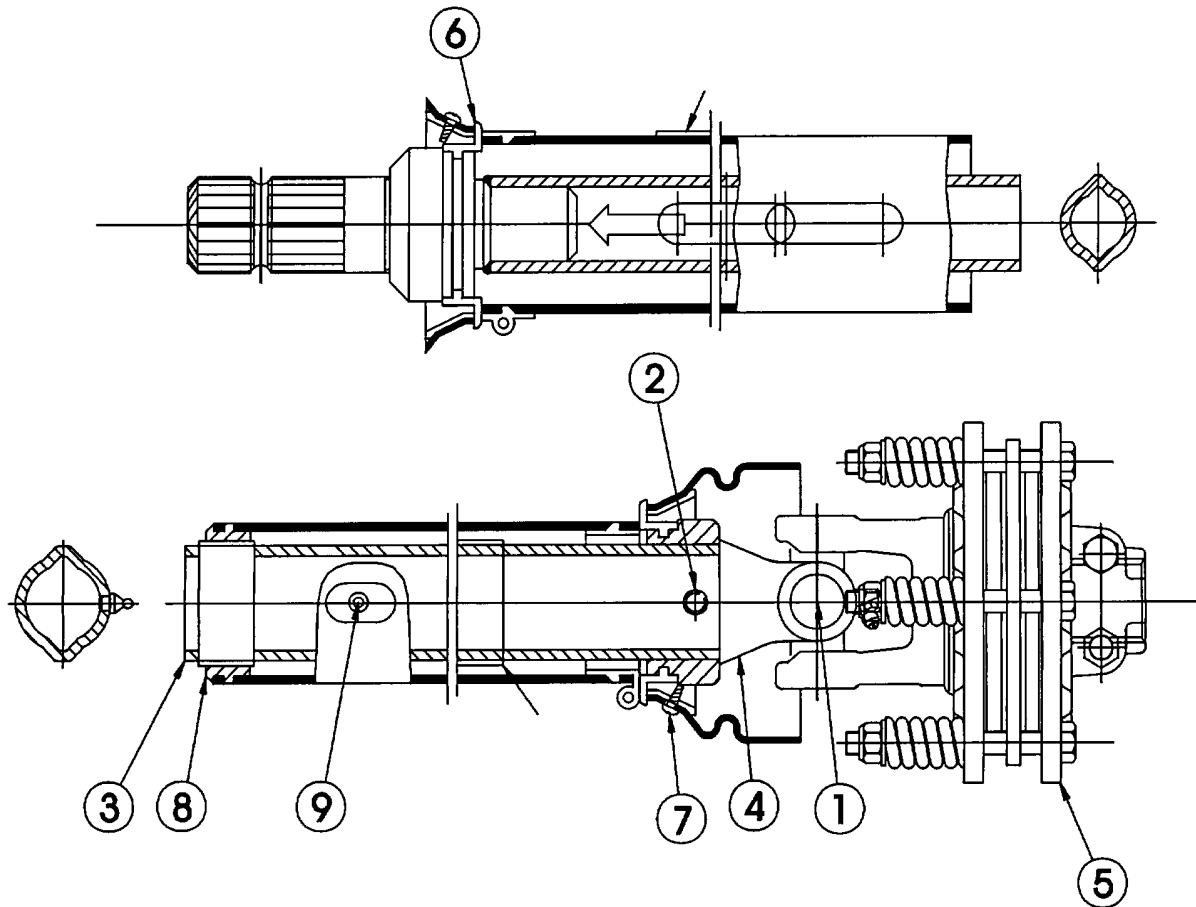

**Order replacement parts from this page if the profile of your driveline is lemon shaped.**

ITEM	PART NO.	QTY.	DESCRIPTION
	<b>00775397</b>	-	<b>DRIVELINE ASSEMBLY</b>
1	W279R	1	CROSS & BEARING KIT
2	8384	1	SPRING PIN
3	00775400	1	PROFILE & SLEEVE
4	00775318	1	INBOARD YOKE
5	00775331	1	FRICTION CLUTCH
6	8393	2	BEARING RING
7	4797	2	SCREW
8	8974	1	SUPPORT BEARING
9	1416601	1	GREASE FITTING
	00775401	1	OUTER SHIELD HALF
	00775402	1	INNER SHIELD HALF

# JACKSHAFT SUPPORT - PULL TYPE

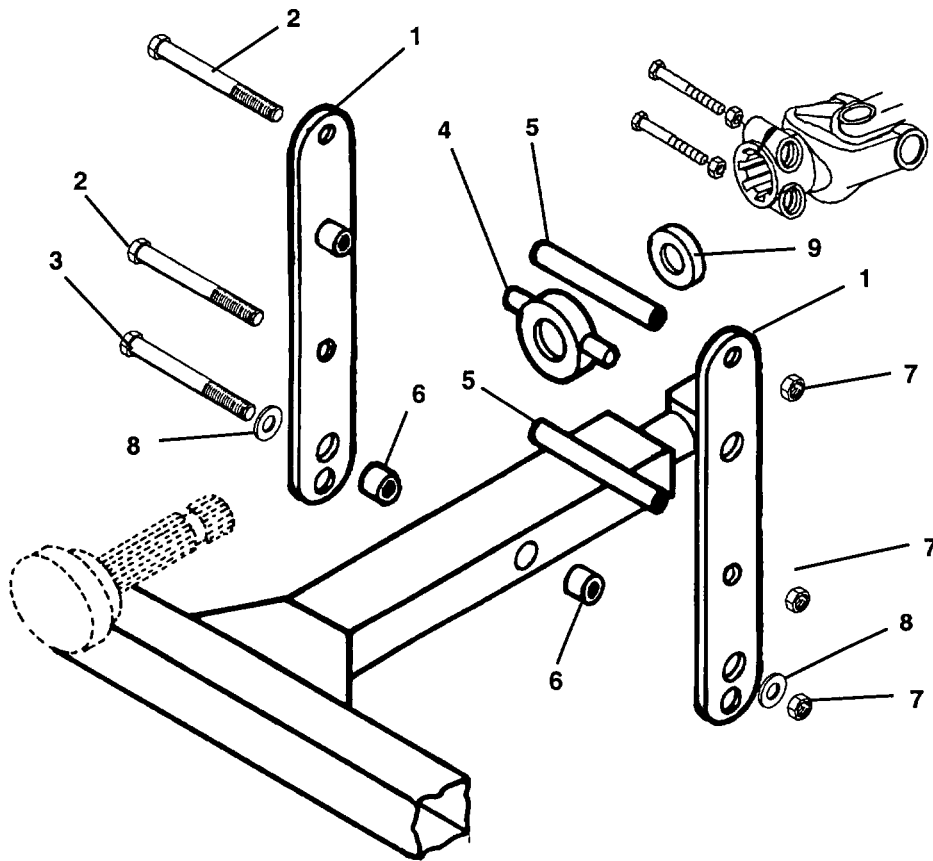

ITEM	PART NO.	QTY.	DESCRIPTION
1	00760944	2	JACKSHAFT SUPPORT WLD'MT
2	00751582	3	BOLT
4	00759100	1	BEARING AND HOUSING ASY.
5	00760943	2	PIPE SPACER
6	681112	2	BUSHING
7	00001800	3	LOCKNUT
8	00002700	2	FLATWASHER
9	00768652	1	SPACER

# BLADE PAN ASSEMBLY

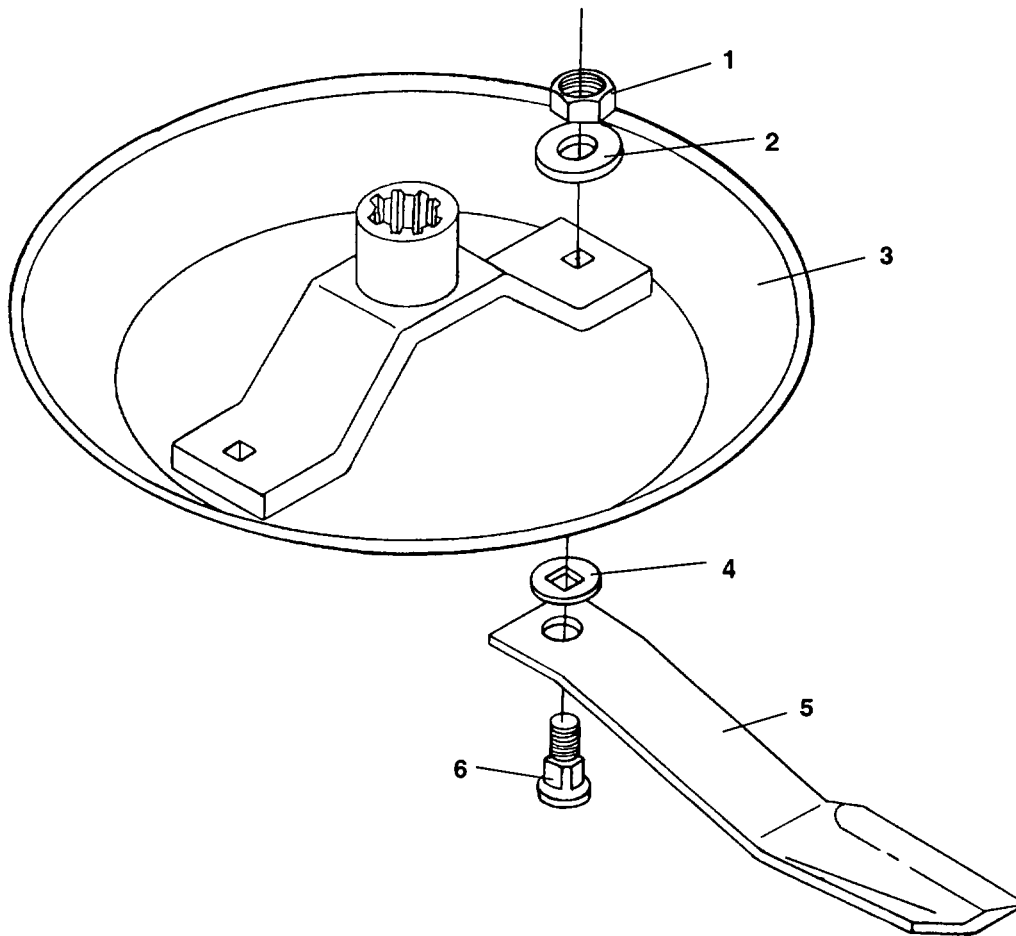

ITEM	PART NO.	QTY.	DESCRIPTION
	<b>00761401</b>	-	<b>BLADE PAN ASY. (CCW - LH)</b>
	<b>00761400</b>	-	<b>BLADE PAN ASY. (CW - RH)</b>
1	5JRC16140	4	LOCKNUT
2	9216	4	WASHER
3	00761399	1	DISHPAN WELDMENT
4	00758579	2	WASHER BLADE
5	00753842	2	BLADE, STD SUCTION ( CCW )
	00769609	2	BLADE, H-LIFT SUCTION (CCW) TWISTED
	00753841	2	BLADE, STD SUCTION ( CW )
	00769610	2	BLADE, HI-LIFT SUCTION (CW) TWISTED
6	8251	4	BLADE BOLT

# SHIELDS

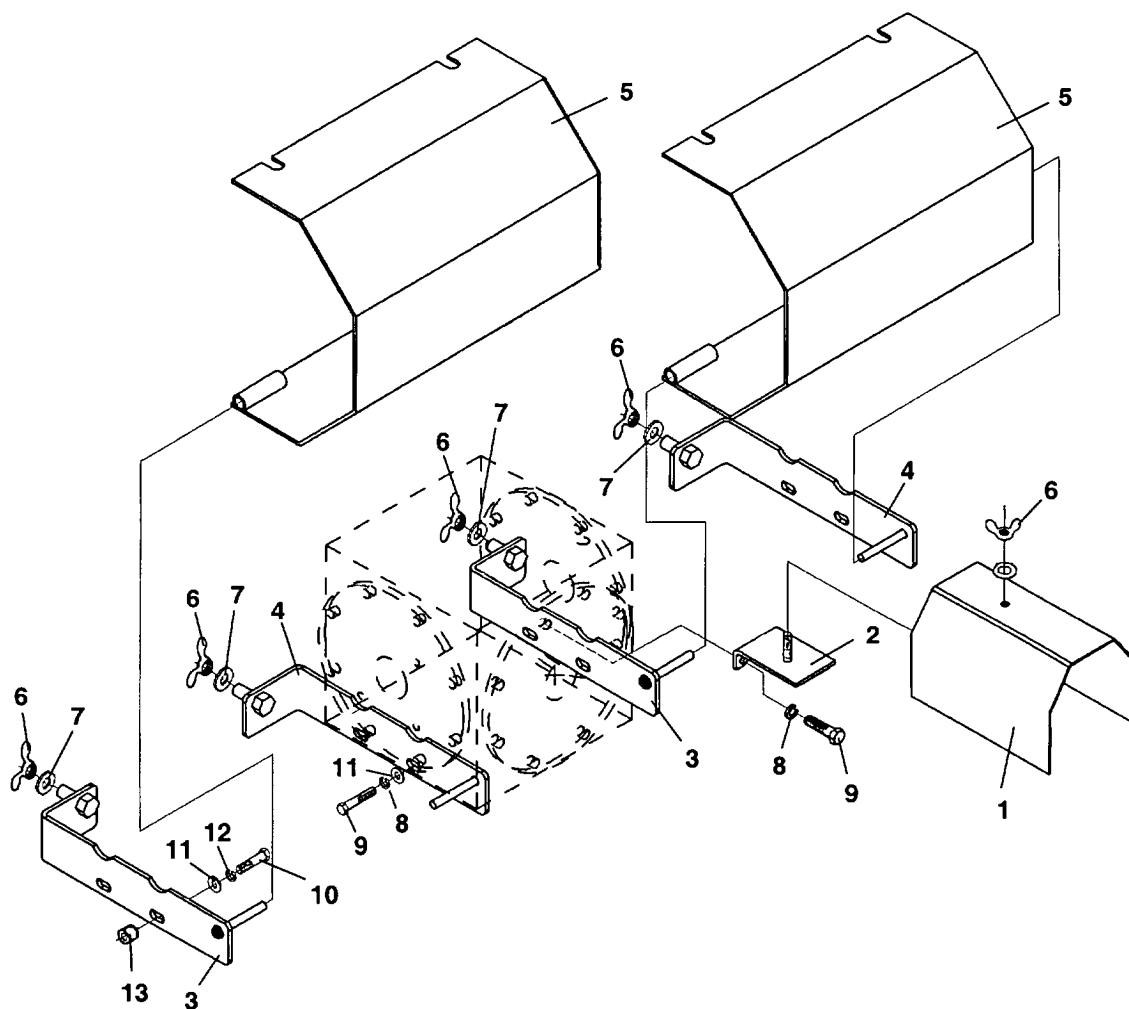

ITEM	PART NO.	QTY.	DESCRIPTION
1	00760909	1	FRONT SHIELD
2	00761405	1	BRACKET WLD'MT
3	00763236	2	BRACKET WLD'MT - RH
4	00763237	2	BRACKET WLD'MT - LH
5	00761342	2	SHIELD WLD'MT
6	5F8130	5	WING NUT
7	00002700	4	FLATWASHER
8	00022200	6*	LOCKWASHER
9	00758659	6*	BOLT
10	00762816	4	BOLT
11	00019700	4	WASHER
12	00012101	4	LOCKWASHER
13	00762837	4	SPACER

\* Existing Hardware

# GEARBOX MOUNT PLATE

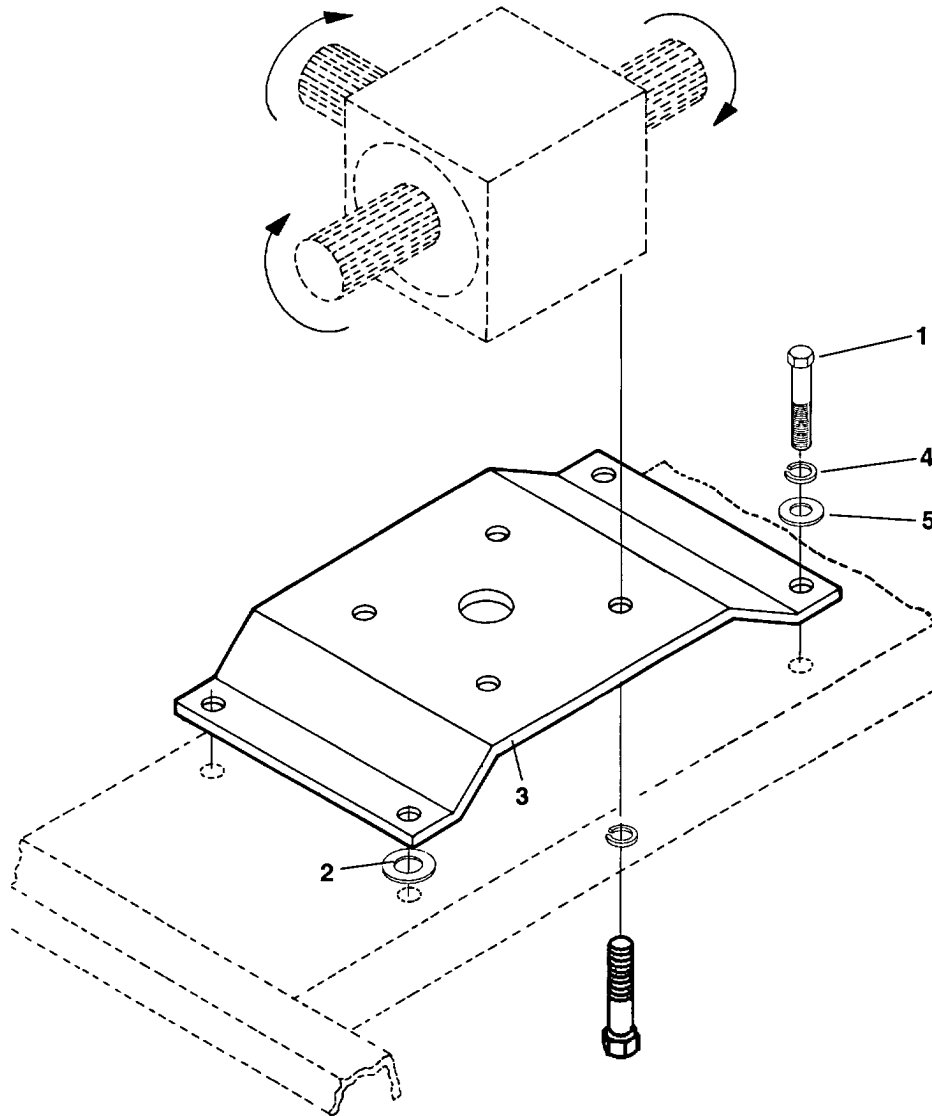

ITEM	PART NO.	QTY.	DESCRIPTION
1	02030700	4	BOLT
2	1169	AR	SHIM WASHER
3	00761447	1	GEARBOX MOUNT PLATE
4	00001300	4	LOCKWASHER
5	00002700	4	FLAT WASHER

# GEARBOX ASSEMBLY - DIVIDER 540 RPM

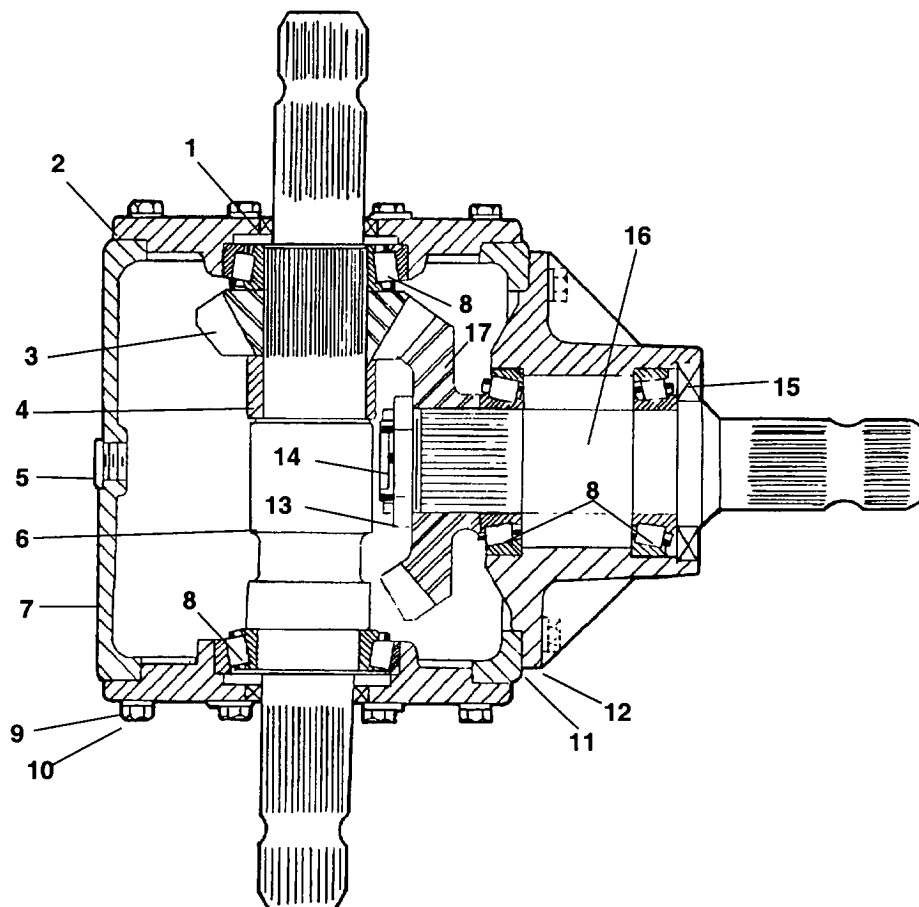

ITEM	PART NO.	QTY.	DESCRIPTION
	<b>00760880</b>	<b>1</b>	<b>GEARBOX ASSEMBLY</b>
1	00758653	2	SEAL
2	00762516	2	CAP - SIDE
3	00758693	1	GEAR - 13 TOOTH
4	00758657	1	SPACER
5	00762517	2	PIPE PLUG
6	00762518	1	SHAFT THRU
7	00762519	1	HOUSING
8	00755628	4	BEARING
9	00755954	24	LOCKWASHER
10	00758659	24	BOLT
11	00748531	AR	SHIM KIT ( INCLUDES 0.40, 0.25, & 0.30 )
12	00762520	1	CAP - HUB INPUT
13	00762121	1	ADJUSTING NUT
14	00026200	1	COTTER PIN
15	00762521	1	SEAL
16	00762522	1	SHAFT INPUT
17	00758694	1	GEAR - 19 TOOTH
18	00762114	1	PIPE PLUG VENTED ( NOT ILLUSTRATED )

NOTE: Shims and Gaskets are Metric Dimensions

# GEARBOX ASSEMBLY - DIVIDER 1000 RPM

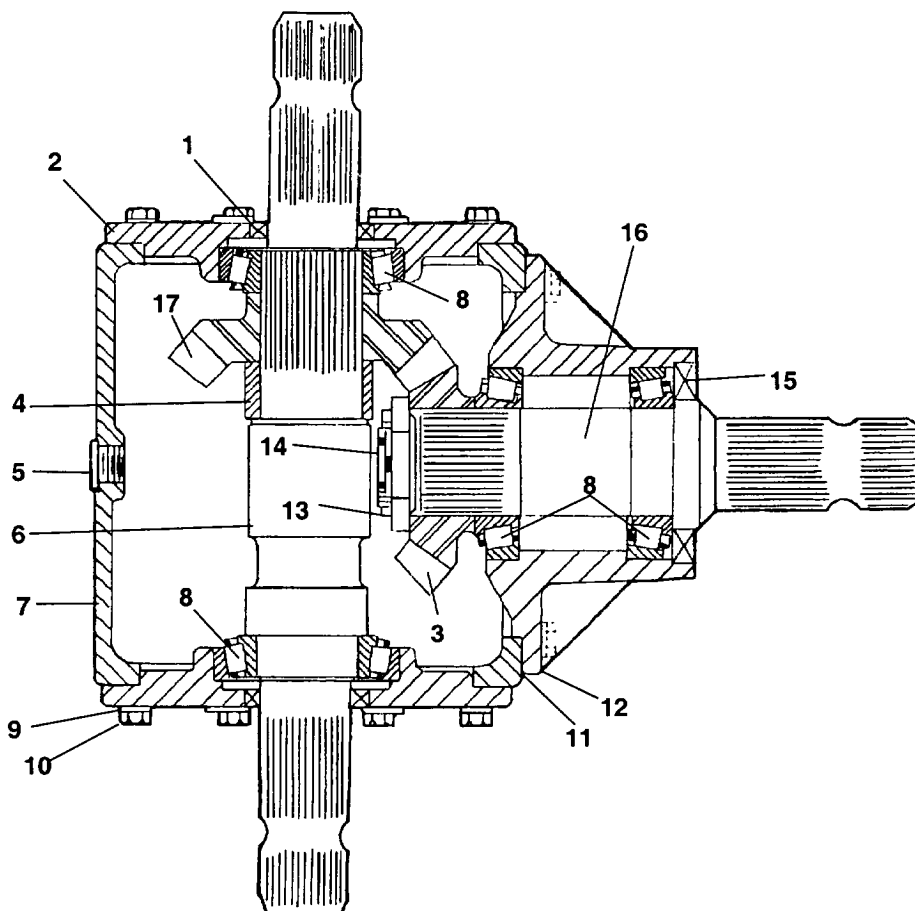

ITEM	PART NO.	QTY.	DESCRIPTION
	<b>00758996</b>	<b>1</b>	<b>GEARBOX ASSEMBLY</b>
1	00758653	2	SEAL
2	00762516	2	CAP - SIDE
3	00759487	1	GEAR - 14 TOOTH
4	00758657	1	SPACER
5	00762517	2	PIPE PLUG
6	00762518	1	SHAFT THRU
7	00762519	1	HOUSING
8	00755628	4	BEARING
9	00755954	24	LOCKWASHER
10	00758659	24	BOLT
11	00748531	AR	SHIM KIT ( INCLUDES 0.40, 0.25, & 0.30 )
12	00762520	1	CAP - HUB INPUT
13	00762121	1	ADJUSTING NUT
14	00026200	1	COTTER PIN
15	00762521	1	SEAL
16	00762522	1	SHAFT INPUT
17	00759488	1	GEAR - 17 TOOTH
18	00762114	1	PIPE PLUG VENTED ( NOT ILLUSTRATED )

NOTE: Shims and Gaskets are Metric Dimensions

# GEARBOX ASSEMBLY - OUTER

P/N 00759205B

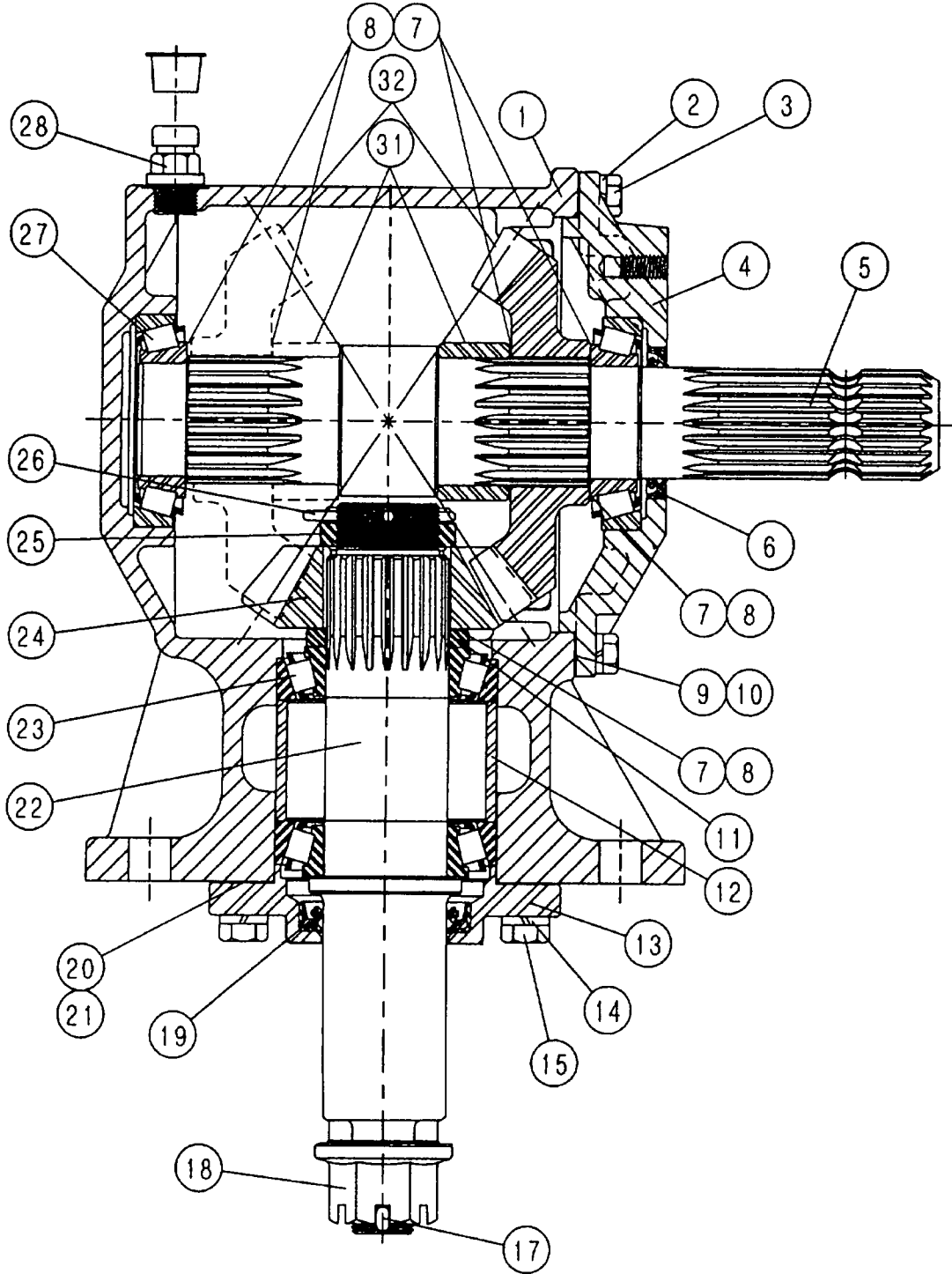

## GEARBOX ASSEMBLY - OUTER

ITEM	PART NO.	QTY.	DESCRIPTION
	<b>00759205B</b>	<b>1</b>	<b>GEARBOX ASSEMBLY</b>
1	00758661	1	HOUSING GEARBOX
2	00755954	8	LOCKWASHER
3	00758659	8	BOLT
4	00758664	1	INPUT CAP
5	00758689	1	INPUT SHAFT
6	00758653	1	OIL SEAL
7	00758667	VAR	SHIM ( 0.30 )
8	00758668	VAR	SHIM ( 0.50 )
9	00758646	VAR	SHIM ( 0.10 )
10	00758647	VAR	SHIM ( 0.25 )
11	00759977	1	SPACER
12	00760889	1	SPACER
13	00758663	1	OUTPUT CAP
14	00758672	4	LOCKWASHER
15	00758673	4	BOLT
17	00606000	1	COTTER PIN
18	00758692	1	NUT
19	00758674	1	OIL SEAL
20	00758676	VAR	OUTPUT CAP GASKET ( 0.10 )
21	00758677	VAR	OUTPUT CAP GASKET ( 0.25 )
22	00760892	1	OUTPUT SHAFT, W/ 00771620 NUT
23	00755628	2	BEARING ASSEMBLY
24	00758693	1	GEAR - 13 TOOTH
25	00770730	1	BEARING ADJUSTING NUT
26	00771620	1	COTTER PIN
27	00758655	2	BEARING ASSEMBLY
28	00762114	1	VENT PLUG ( DIA.=0.7 ) W/ SEAL WASHER
31	00758657	1	SPACER
32	00758694	1	GEAR - 19 TOOTH
33	00769321	1	WASHER SEALING ( NOT SHOWN )

# DRIVELINE COUPLER S/N 01604 & BELOW Rev 09-04

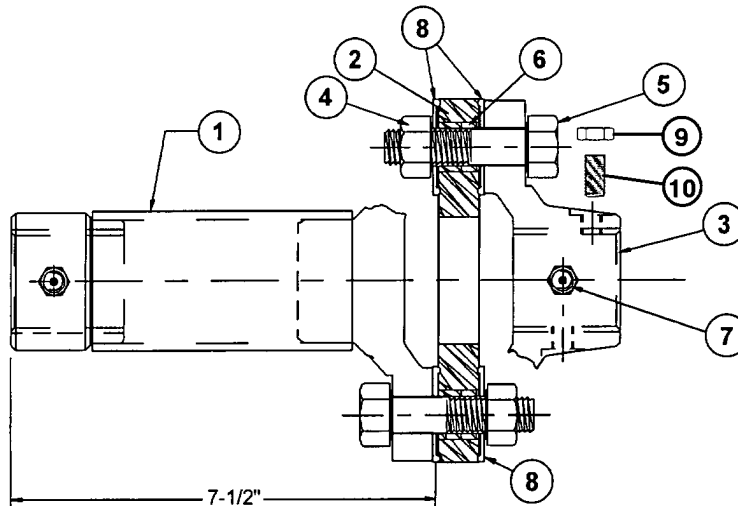

ITEM	PART NO.	QTY.	DESCRIPTION
	<b>00761346A</b>	<b>1</b>	<b>DRIVELINE ASY.</b>
1	00762460A	1	SLEEVE WLD'MT
2	00762215	1	RUBBER DISC
3	00762216A	1	SPIDER
	00762216	1	SPIDER ( OLD STYLE )
4	00765962	6	LOCKNUT
5	02964434	6	BOLT
6	00771287	6	COUPLER BUSHING
7	00764386	2	GREASE FITTING
8	00766475A	12	BEADED WASHER
9	3167	1	SET SCREW
10	5C6160	1	JAM NUT

# DRIVELINE COUPLER S/N 01605 (09-04) to S/N 01645 (01-05)

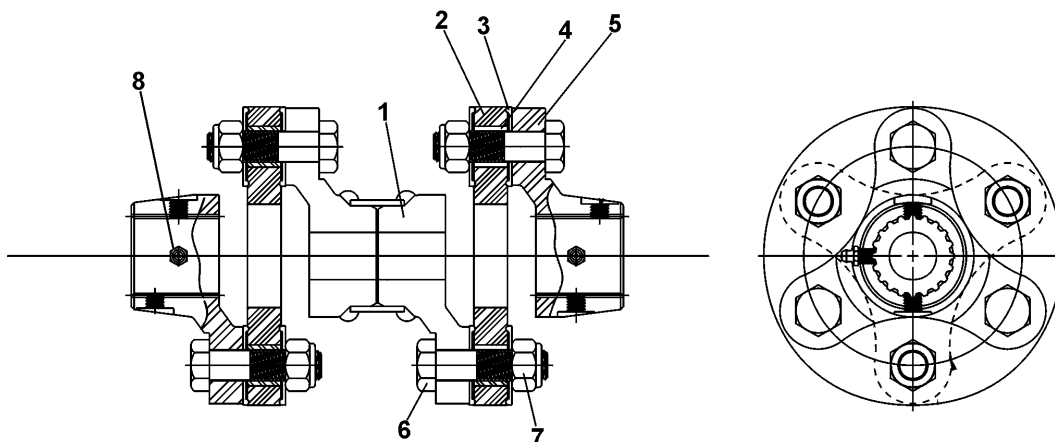

ITEM	PART NO.	QTY.	DESCRIPTION
	<b>00776946</b>	-	<b>SINGLE FLEX COUPLER SHAFT</b>
1	00776949	1	DOUBLE FLEX YOKE WLD'MT
2	00762215	2	RUBBER DISC ( W/O BUSHINGS )
3	00766475A	24	BEADED WASHER, D/L COUPLER
4	00771287	12	RUBBER DISK BUSHING
5	00762216A	2	DRIVELINE SPIDER, 1-3/4" - 20 SPLINE.
6	00765902	12	METRIC BOLT
7	00765962	12	NUT
8	00764386	2	GREASE FITTING

# DRIVELINE COUPLER S/N 01646 (01-05) to CURRENT

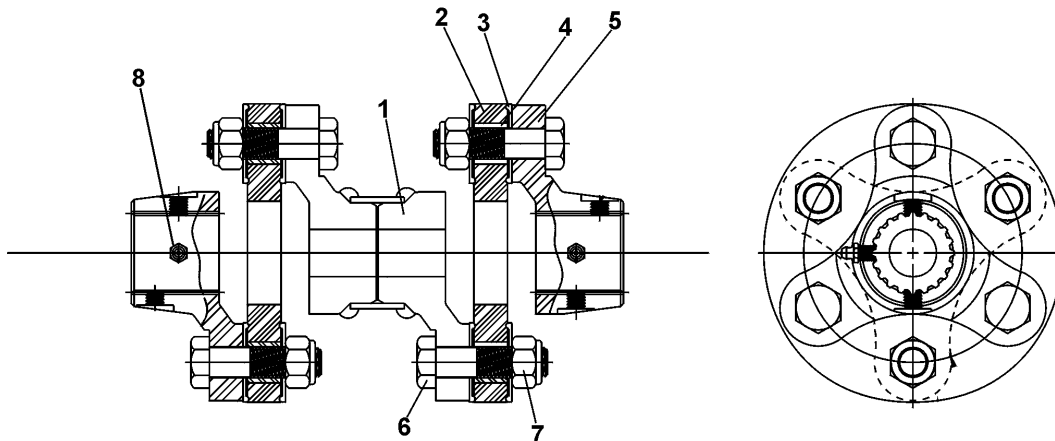

ITEM	PART NO.	QTY.	DESCRIPTION
	<b>00778146</b>	-	<b>FLEX COUPLER SHAFT ASY. ( COMPLETE )</b>
1	00778169	1	DOUBLE FLEX YOKE WLD'MT
2	00762215	2	RUBBER DISC ( W/O BUSHINGS )
3	00766475A	24	BEADED WASHER, D/L COUPLER
4	00771287	12	RUBBER DISK BUSHING
5	00762216A	2	DRIVELINE SPIDER, 1-3/4" - 20 SPLINE
6	00765902	12	METRIC BOLT
7	00765962	12	NUT
8	00764386	2	GREASE FITTING

## DRIVELINE COUPLER - OPTIONAL TYPE

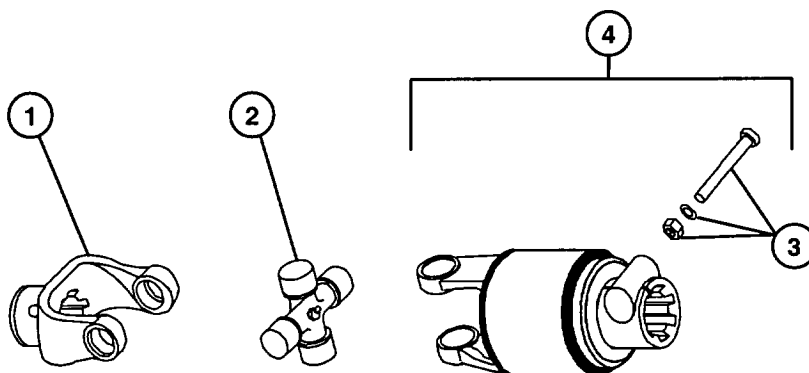

ITEM	PART NO.	QTY.	DESCRIPTION
	<b>00767894</b>	<b>1</b>	<b>DRIVE LINE COUPLER ASY.</b>
1	00774148	1	SPECIAL YOKE
2	00752896	1	CROSS & BEARING KIT
3	00774147	1	TAPERED PIN SET
4	00774146	1	COMPLETE RUBBER ELEMENT

# DEFLECTOR ASSEMBLY - FRONT

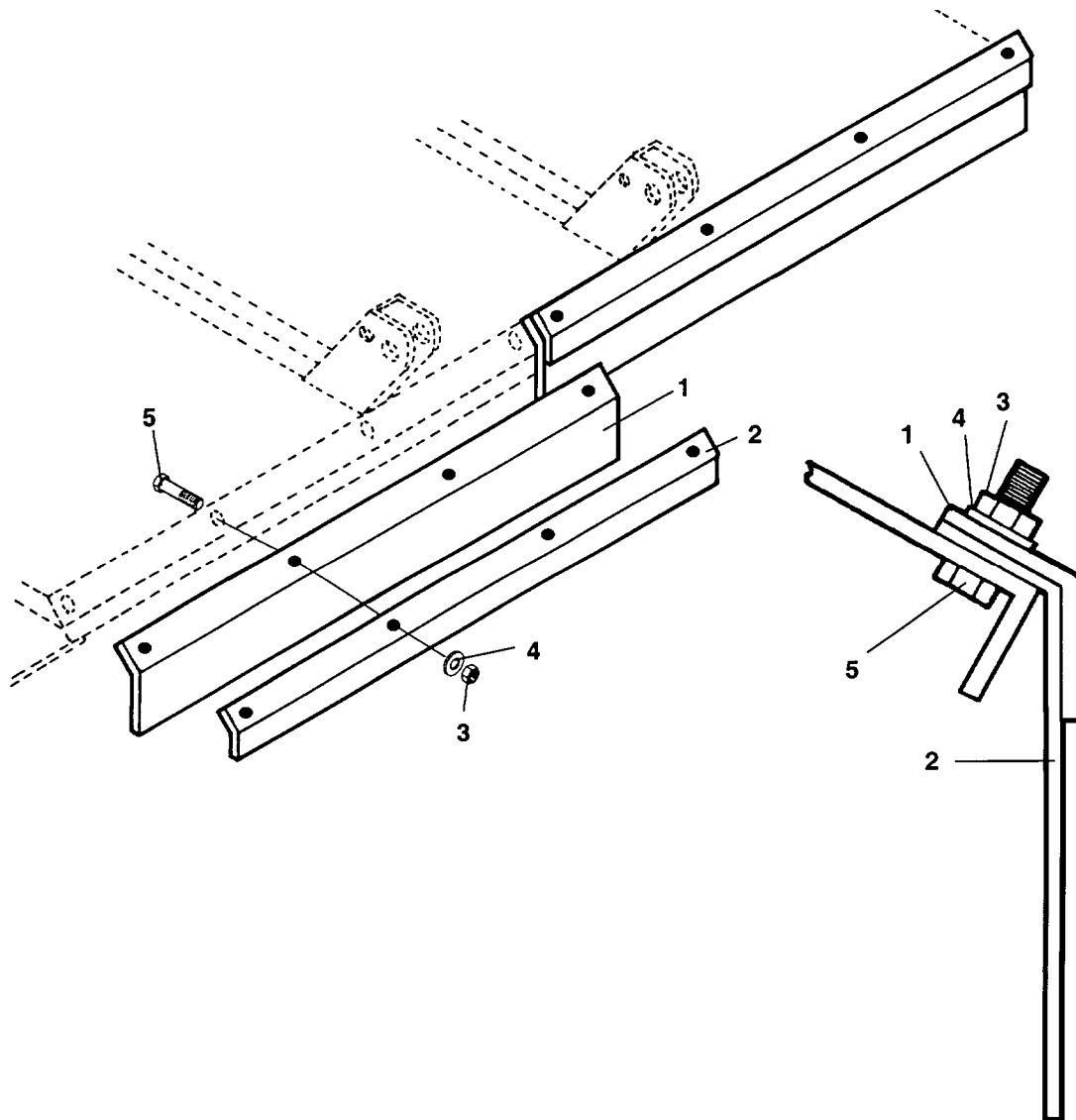

ITEM	PART NO.	QTY.	DESCRIPTION
	<b>00761647</b>	<b>1</b>	<b>DEFLECTOR ASY.</b>
1	00761973	2	FRONT SHIELD DEFLECTOR
2	00761972	2	STRAP BRACKET
3	00001800	8	NUT
4	00002700	8	FLATWASHER
5	02030700	8	BOLT

# DEFLECTOR ASSEMBLY - REAR

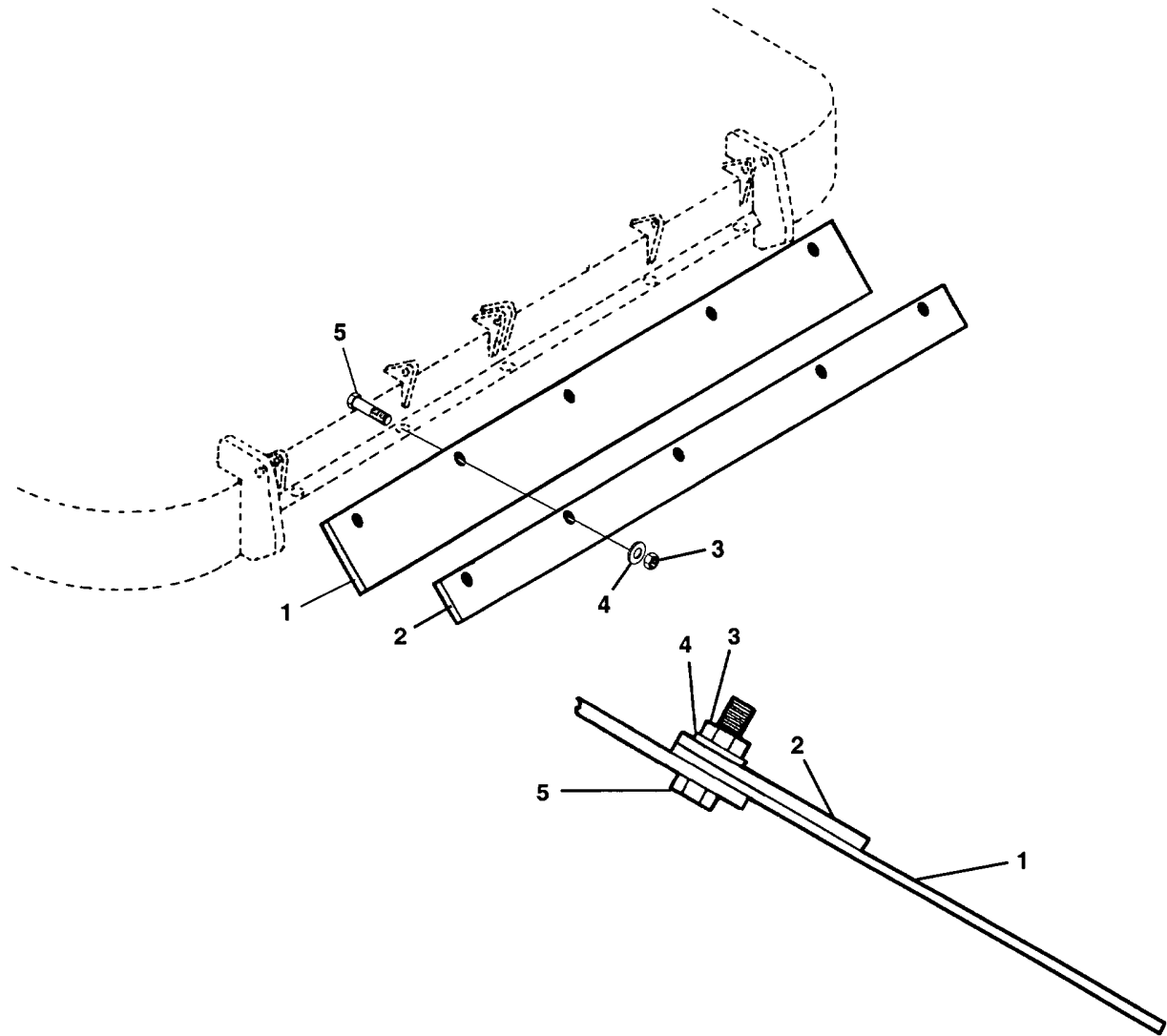

ITEM	PART NO.	QTY.	DESCRIPTION
	<b>00761648</b>	<b>1</b>	<b>DEFLECTOR ASY.</b>
1	00761970	1	REAR DEFLECTOR SHIELD
2	00761971	1	BAR STRAP
3	00001800	5	NUT
4	00002700	5	WASHER
5	02030700	5	BOLT

# CHAIN GUARD ASSEMBLY - FRONT

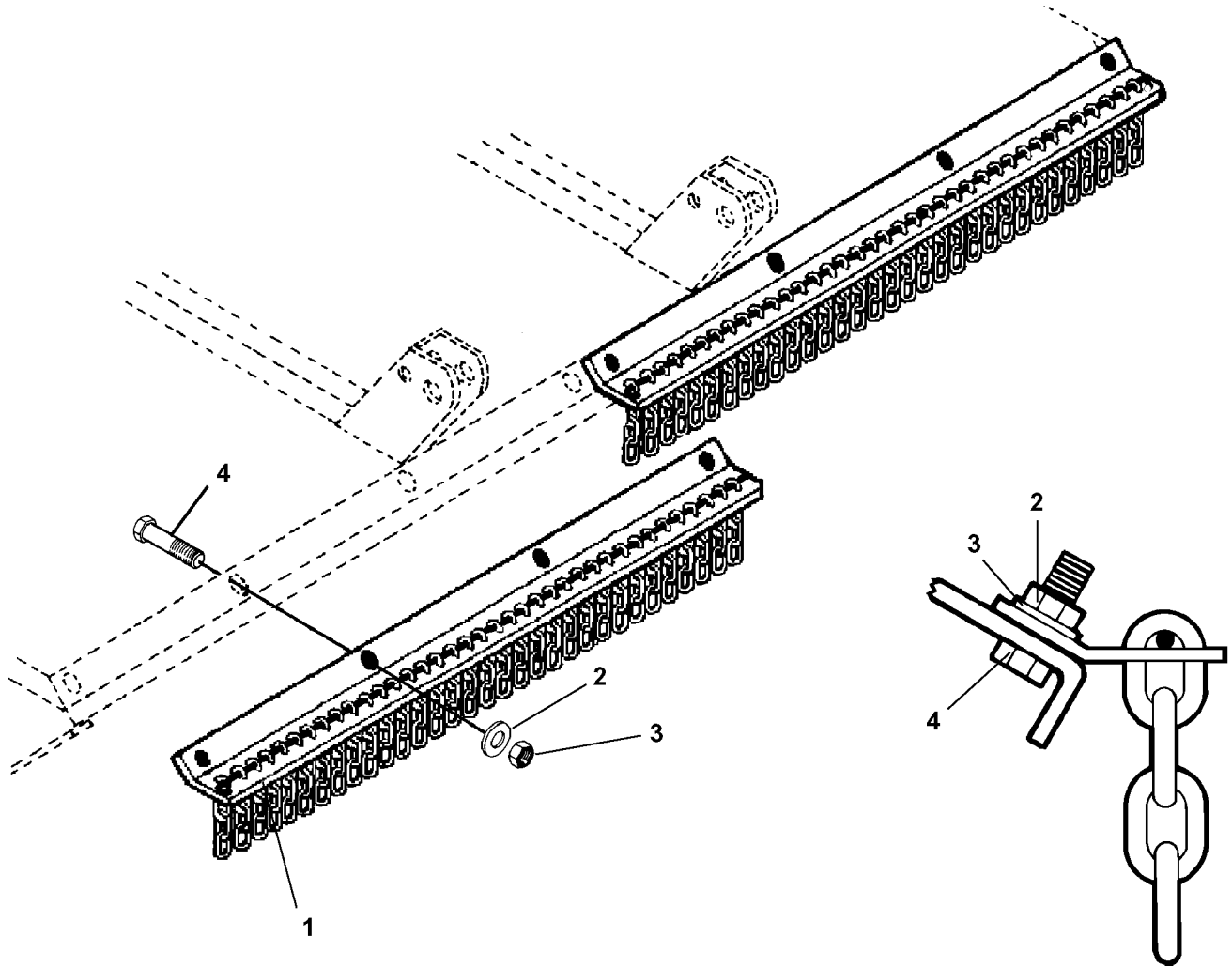

ITEM	PART NO.	QTY.	DESCRIPTION
1	00761867	2	FRONT CHAIN GUARD ASY.
2	00001800	8	LOCKNUT
3	00002700	8	FLATWASHER
4	02030700	8	BOLT

# CHAINGUARD ASSEMBLY - REAR

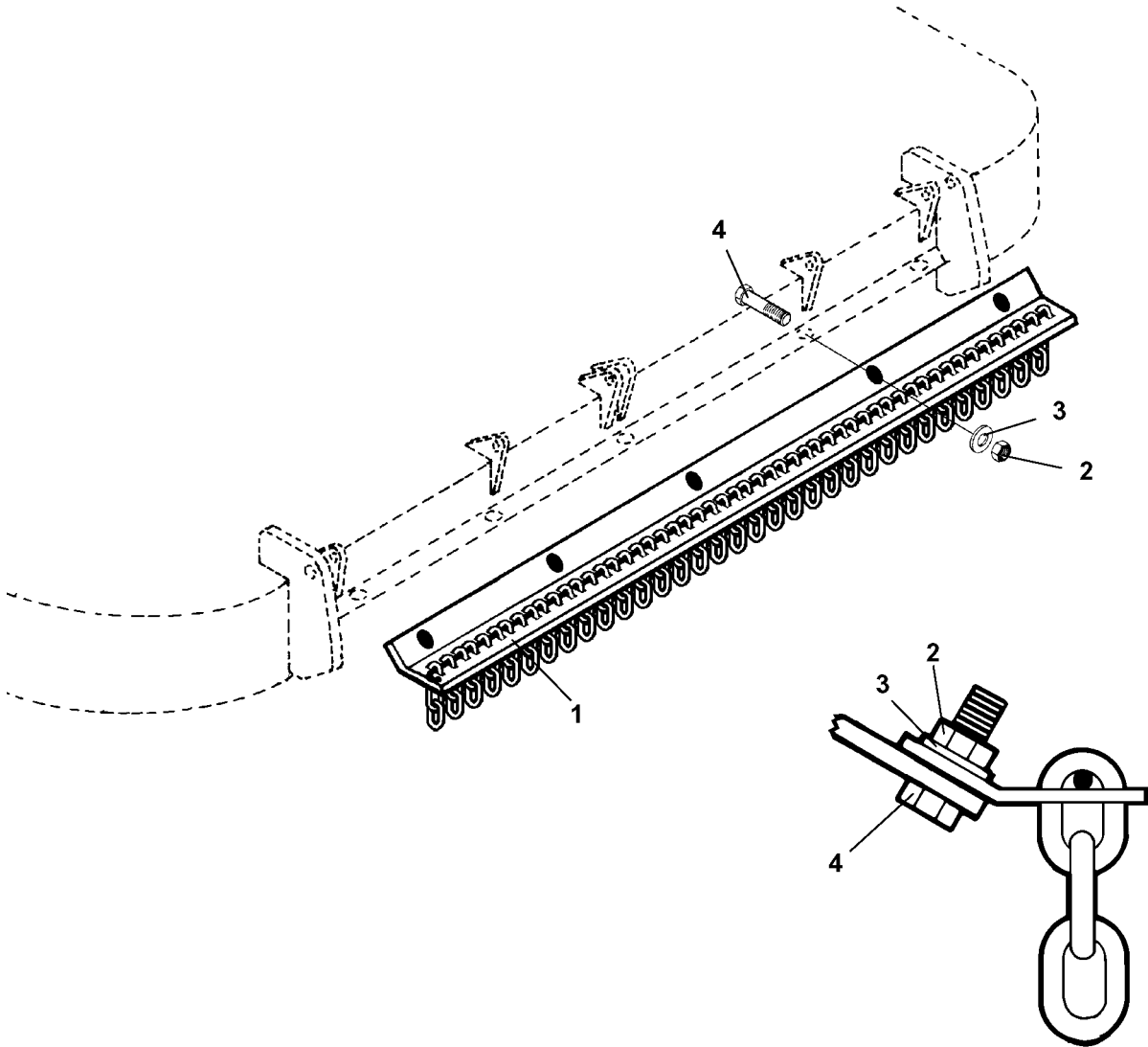

ITEM	PART NO.	QTY.	DESCRIPTION
1	00761868	1	REAR CHAIN GUARD ASY.
2	00001800	5	LOCKNUT
3	00002700	5	FLATWASHER
4	02030700	5	BOLT

# DRIVELINE ASSEMBLY - CV

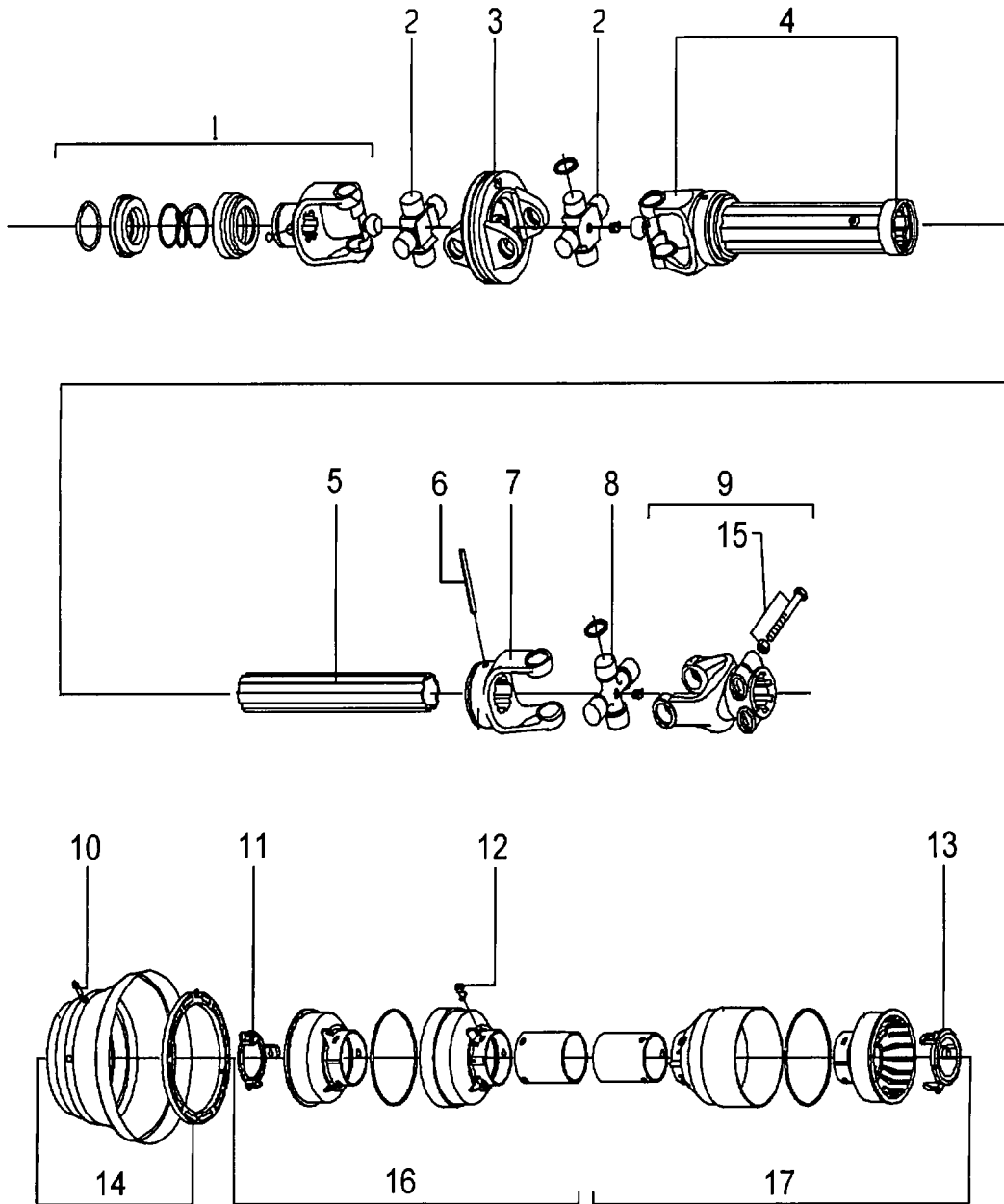

## DRIVELINE ASSEMBLY - CV

ITEM	PART NO.	QTY.	DESCRIPTION
	<b>00772707</b>		<b>DRIVELINE ASY. ( 540 RPM )</b>
	<b>00772706</b>		<b>DRIVELINE ASY. ( 1000 RPM )</b>
1	00773483	1	COMPLETE COLLAR YOKE ( 540 RPM )
	00773473	1	COMPLETE COLLAR YOKE ( 1000 RPM )
2	00773474	2	CROSS & BEARING KIT
3	00773475	1	WIDE ANGLE DOUBLE YOKE
4	00773476	1	COMPLETE OUTER TUBE W/ YOKE
5	00773477	1	INNER TUBE
6	00754167	1	ROLL PIN FOR INNER TUBE
7	00754153	1	INNER YOKE
8	00773478	1	CROSS & BEARING SET
9	00771337	1	INTERFERING CLAMP BOLT YOKE
10	00773479	6	SCREW
11	00754332	1	LOCKING COLLAR OUTER SHIELD
12	00754330	6	BOLT
13	00754331	1	LOCKING COLLAR INNER SHIELD
14	00773480	1	GUARD CONE SET
15	00773289	2	BOLT
16	00773481	1	HALF OUTER GUARD
17	00773482	1	HALF GUARD

# JACKSHAFT ASSEMBLY - CV DRIVELINE

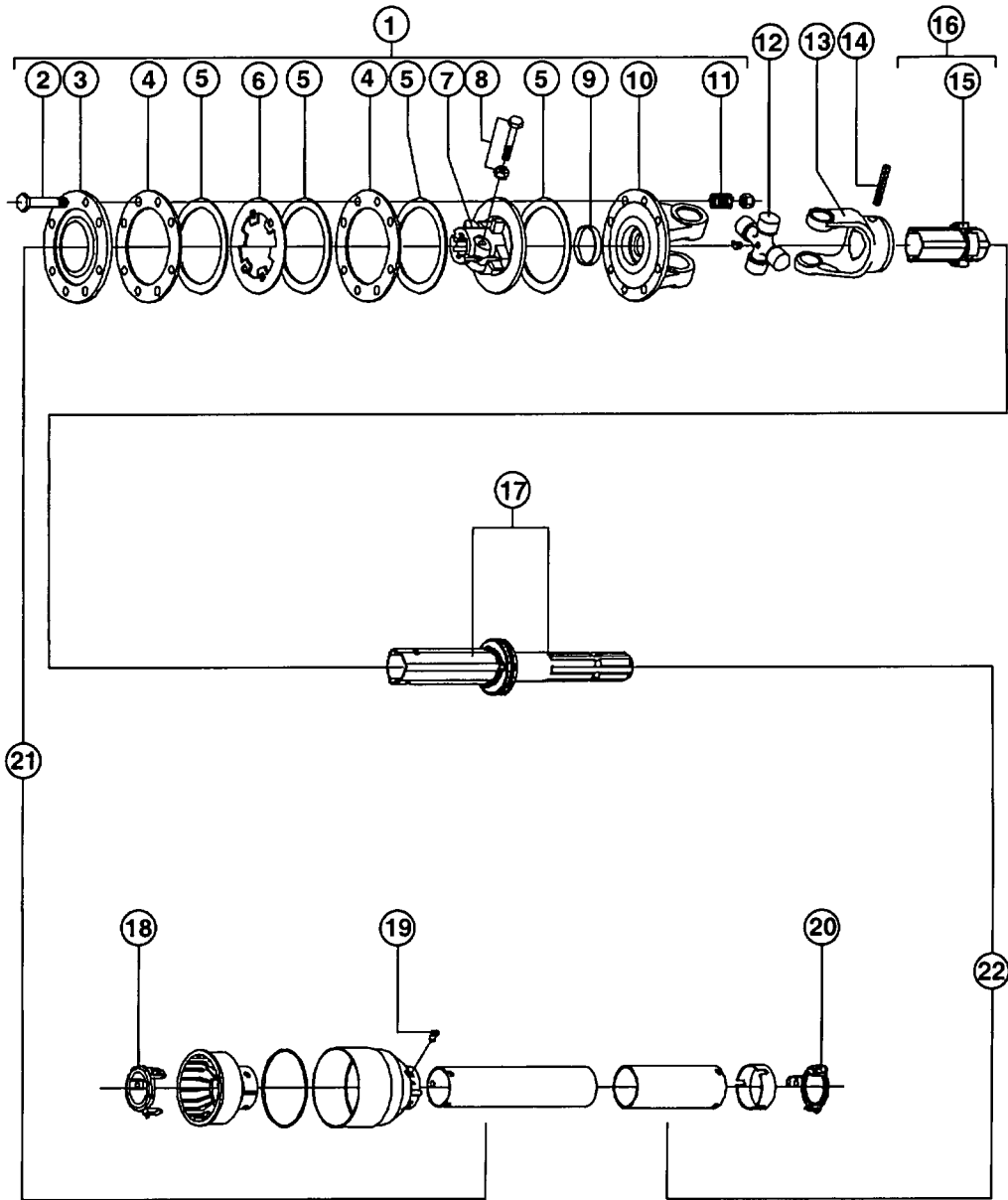

## JACKSHAFT ASSEMBLY - CV DRIVELINE

ITEM	PART NO.	QTY.	DESCRIPTION
	<b>00773121</b>	-	<b>JACKSHAFT ASSEMBLY</b>
1	00756075	1	SLIP CLUTCH ( W/ SPRING )
2	00754199	8	BOLT
3	00754203	1	PRESSURE PLATE
4	00754314	2	INNER PLATE
5	00754202	4	LINING RING
6	00754201	1	INERMEDATE PLATE
7	00755599	1	CLUTCH SUPPORT
8	00755600	2	BOLT
9	00754301	1	BUSHING
10	00754302	1	FLANGED YOKE
11	00754303	8	SPRING
12	00752896	1	CROSS & BEARING KIT
13	00754154	1	OUTER YOKE
14	00754167	1	ROLL PIN FOR OUTER TUBE
15	00772529	1	BUSHING, W/ GREASE FITTING
16	00773584	1	COMPLETE OUTER TUBE
17	00773585	1	INNER TUBE, W/ SPLINE SHAFT
18	00754332	1	GUARD RETAINING COLLAR
19	00754330	6	BOLT
20	00754331	1	GUARD RETAINING COLLAR
21	00773587	1	HALF OUTER SHAFT, W/ GUARD
22	00773586	1	HALF INNER SHAFT, W/ GUARD

# TONGUE & JACKSHAFT ASSY - CV DRIVELINE OPTION

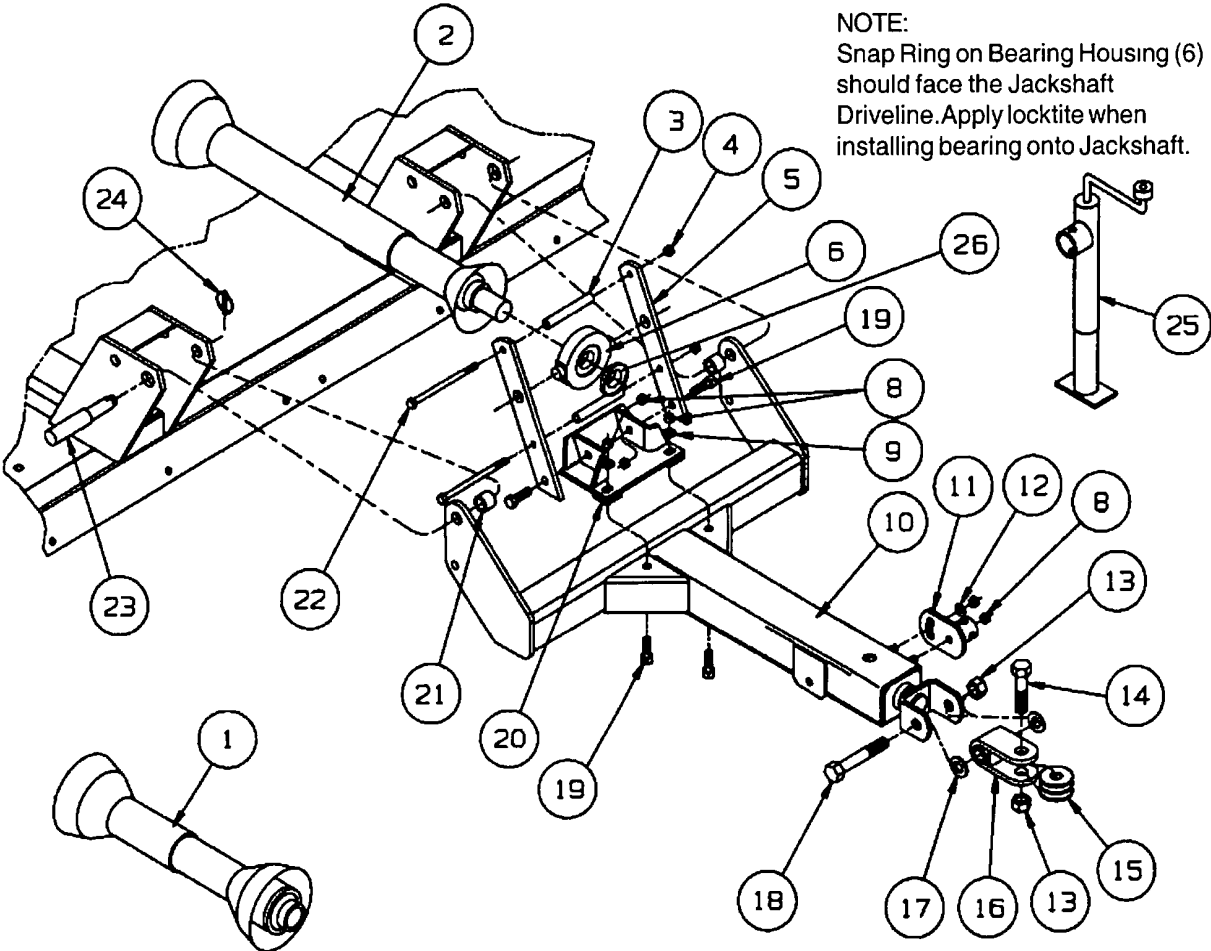

## TONGUE & JACKSHAFT ASSY - CV DRIVELINE OPTION

ITEM	PART NO.	QTY.	DESCRIPTION
1	00772707	1	MAIN DRIVELINE - 540 RPM CV
	00772706	1	MAIN DRIVELINE - 1000 RPM CV
2	00773121	1	JACKSHAFT ASY.
3	00764457	2	PIPE SPACER
4	00001800	2	LOCKNUT
5	00773059	2	JACKSHAFT SUPPORT
6	00773088	1	BEARING & HOUSING
	00764417	1	BEARING
8	00695100	6	LOCKNUT
9	00756077	2	WASHER
10	00765810	1	TONGUE
11	00760941	1	JACK TUBE MOUNT
12	00001400	1	FLATWASHER
13	02030300	2	LOCKNUT
14	02712500	1	BOLT
15	00759275	3	HITCH CLEVIS WASHER
16	00748807	1	CLEVIS
17	00757478	2	SPRING WASHER
18	00755305	1	BOLT
19	02845500	4	BOLT
20	00773068	1	JACKSHAFT MOUNT
21	00761890	2	BUSHING
22	00751582	2	BOLT
23	69141	2	PIVOT PIN
24	2196	2	LYNCH PIN
25	00756655	1	PARKING JACK
26	00768682	1	SPACER

# SKID SHOE ASSEMBLY

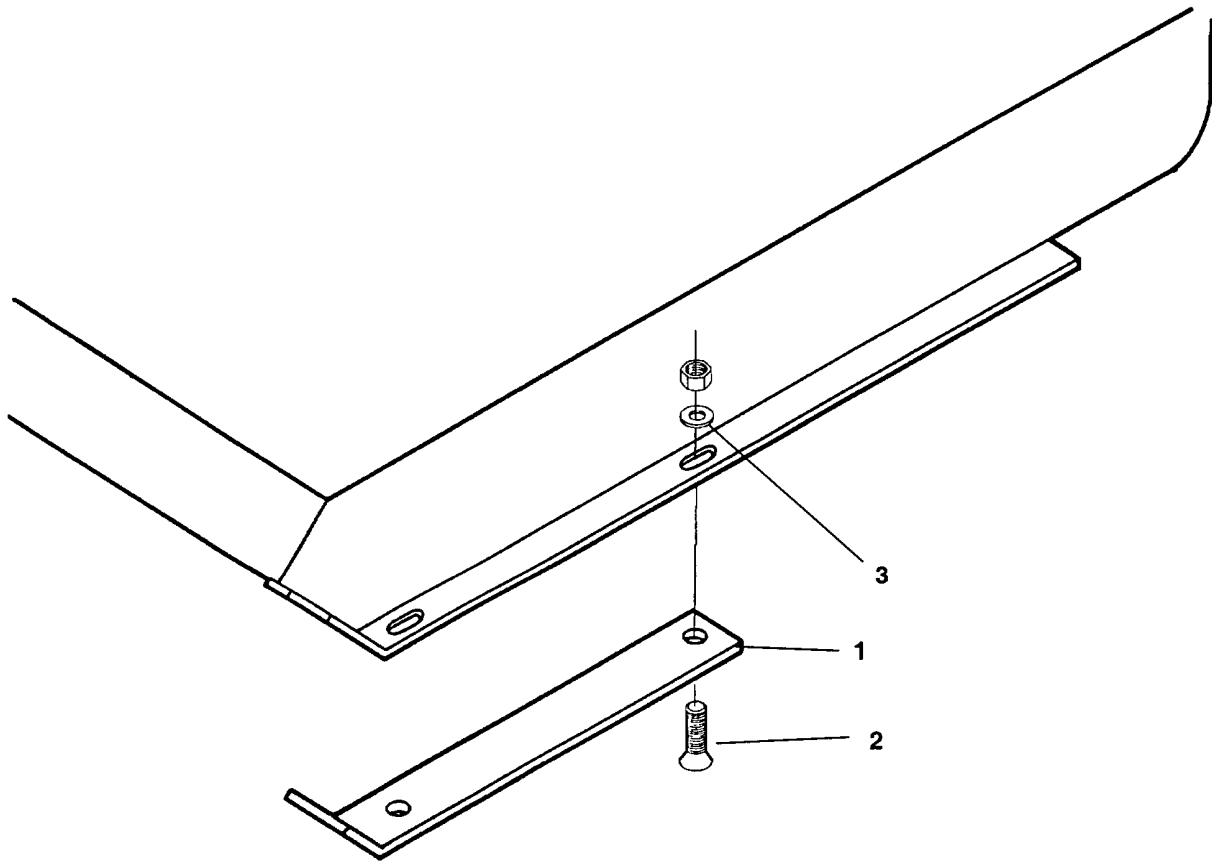

ITEM	PART NO.	QTY.	DESCRIPTION
1	0622000001	2	SKID SHOE
2	2A361612	6	PLOW BOLT
3	4528	6	FLANGE NUT

# CONTROL ROD ASSEMBLY - CV DRIVELINE OPTION

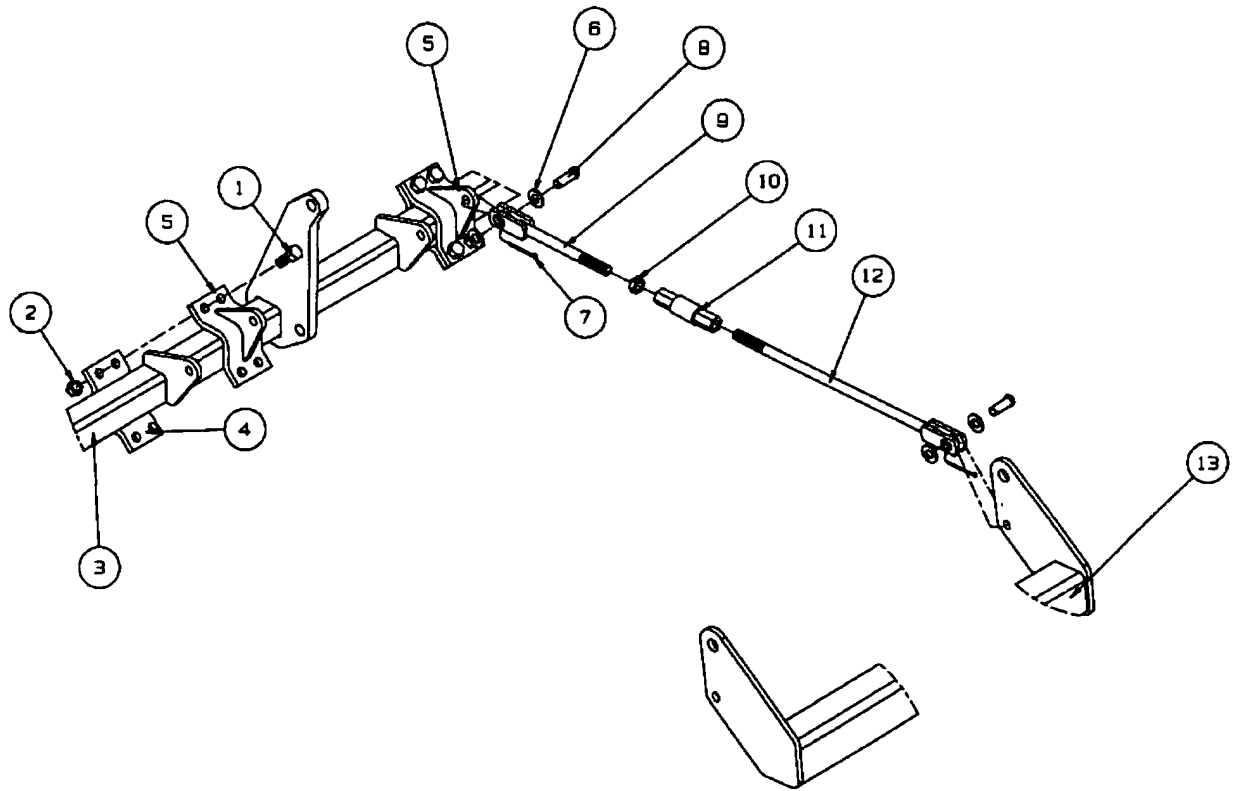

ITEM	PART NO.	QTY.	DESCRIPTION
1	00037100	8	BOLT
2	00037200	8	NUT
3	00761271	1	AXLE
4	00773225	2	TUBE CLAMP
5	00773235	2	CONTROL ROD, CLAMP LUG
6	15B1200	8	FLATWASHER
7	00755153	4	COTTER PIN
8	651102	4	PIN
9	00758643	2	SHORT, CONTROL ROD
10	5C1490	2	JAMNUT
11	00770485	2	ADJUSTING NUT
12	00773132	2	LEVEL ROD
13	00765810	1	TONGUE

# DRIVELINE ASSEMBLY - CV

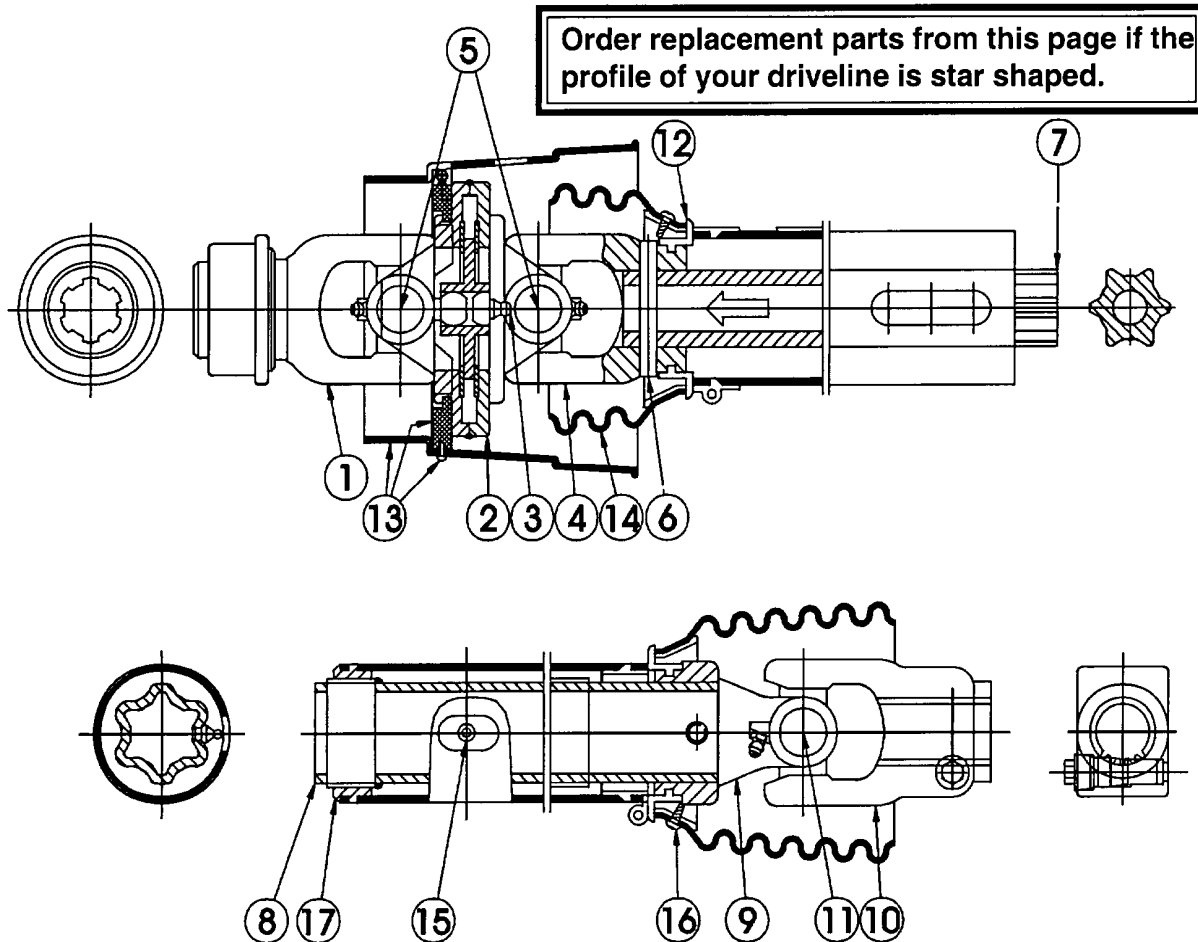

ITEM	PART NO.	QTY.	DESCRIPTION
	<b>00775422</b>	-	<b>DRIVELINE ASY.</b>
1	00775353	1	YOKE
2	W279R	2	CROSS & BEARING KIT
3	8384	2	SPRING PIN
4	00775317	1	INBOARD YOKE
5	0921000332	1	INNER PROFILE
6	00775378	1	PROFILE & SLEEVE WLD'MT
7	00775318	1	INBOARD YOKE
8	00775419	1	FRICTION CLUTCH
9	8393	2	BEARING RING
10	4797	2	SCREW
11	8974	1	SUPPORT BEARING
12	1416601	1	ZERK
13	00775427	1	OUTER SHIELD HALF
14	00775428	1	INNER SHIELD HALF
15	00767954	1	YOKE QD KIT
16	8371	1	QD FLANGE KIT

# TONGUE ASSEMBLY (OFFSET MODEL)

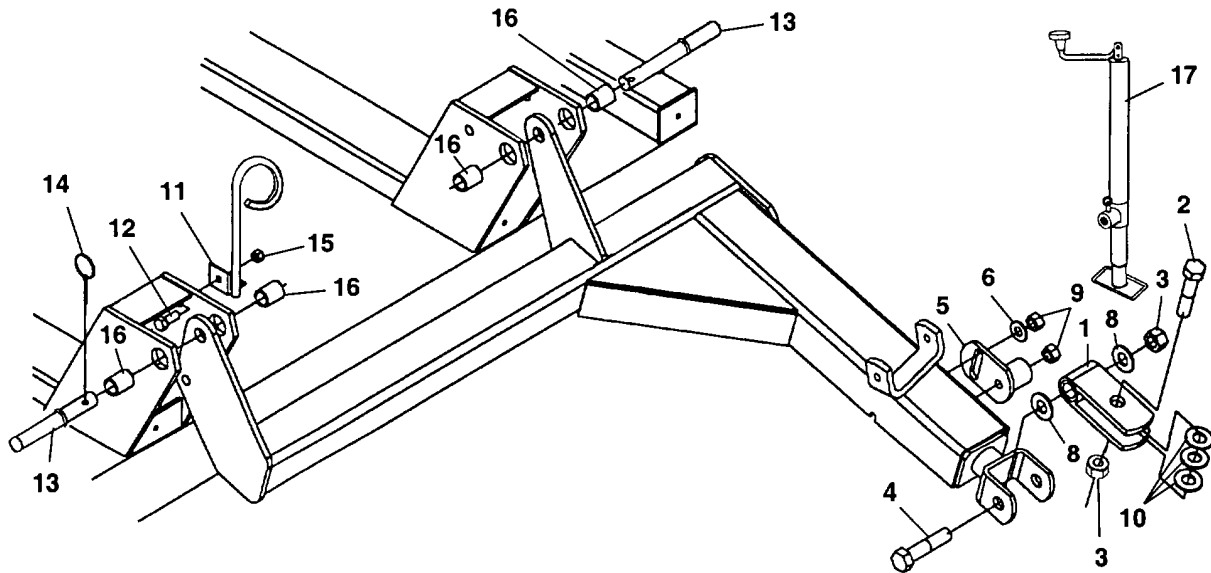

ITEM	PART NO.	QTY.	DESCRIPTION
1	00748807	1	CLEVIS WLD'MT
2	02712500	1	BOLT
3	02030300	2	NUT
4	00755305	1	BOLT
5	00760941	1	JACK TUBE MOUNT
6	00001400	1	FLAT WASHER
8	00757478	2	SPRING WASHER
9	00695100	2	LOCKNUT
10	00759275	3	WASHER
11	8343	1	HOSE HOLDER
12	00748823	1	BOLT
13	00767641	2	PIN HITCH
14	2196	2	CLIP
15	00001800	1	NUT
16	4962	4	BUSHING
17	00772391	1	PARKING JACK

# GEARBOX ASSMEBLY - SIDE (OFFSET MODEL)

P/N 00771225P

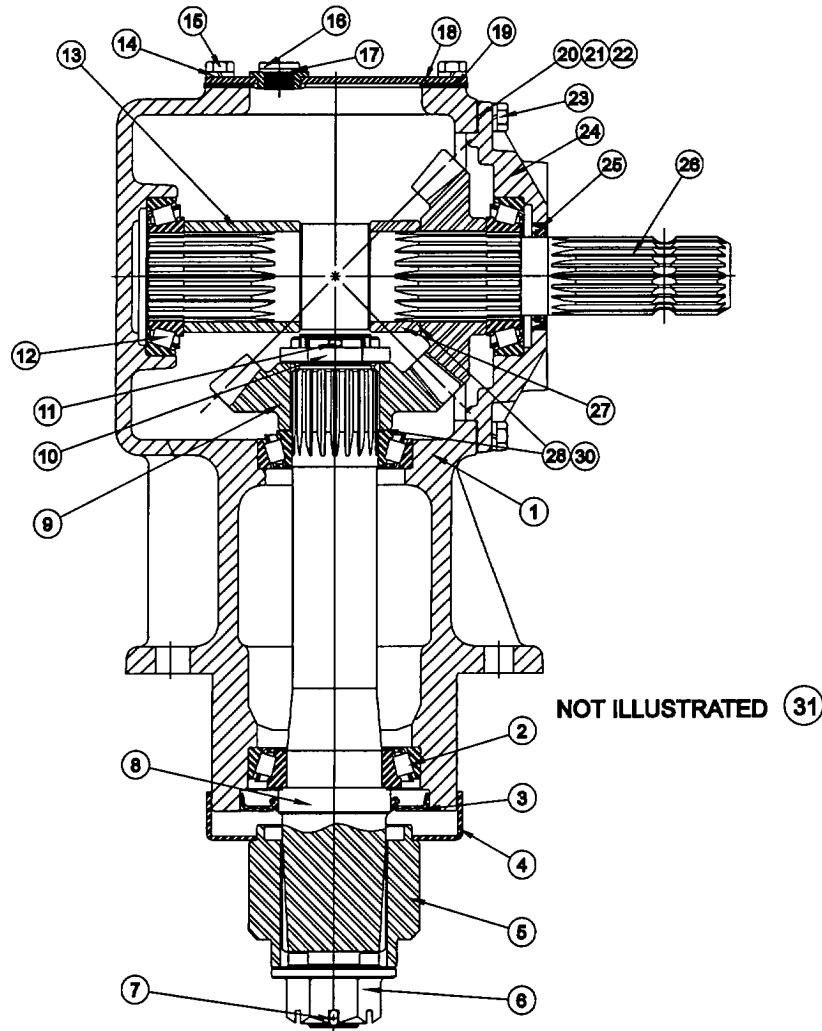

## GEARBOX ASSMEBLY - SIDE (OFFSET MODEL)

ITEM	PART NO.	QTY.	DESCRIPTION
1	00770724	1	HOUSING
2	00770725	1	BEARING ASSEMBLY
3	00770726	1	OIL SEAL
4	00770727	1	SEAL PROTECTOR
5	00771227	1	BLADE HUB
6	00771226	1	FLANGE NUT
7	01422502	1	COTTER PIN
8	00770728	1	VERTICAL OUTPUT SHAFT
9	00770736	2	PINION GEAR - 13 TOOTH
10	00762121	1	BEARING ADJUSTMENT
11	00606000	1	COTTER PIN
12	00755628	3	BEARING ASSEMBLY
13	00770731	1	INPUT SHAFT SPACER
14	00766083	12	LOCKWASHER
15	00754338	4	HEAD BOLT
16	00762517	2	PIPE PLUG
17	00769321	3	SEALING WASHER
18	00770732	1	INSPECTION COVER
19	00770733	1	COVER GASKET
20	00758646	VAR	SHIM
21	00758647	VAR	SHIM
22	00758648	VAR	SHIM
23	00765905	8	BOLT
24	00770734	1	INPUT CAP
25	00758653	1	OIL SEAL
26	00770735	1	INPUT SHAFT
27	00758657	1	INPUT SHAFT SPACER
28	00758667	VAR	SHIM
30	00758668	VAR	SHIM
31	00762114	1	PLUG RELIEF VALVE

# GEARBOX - CENTER 540 RPM (OFFSET MODEL)

P/N 00757918

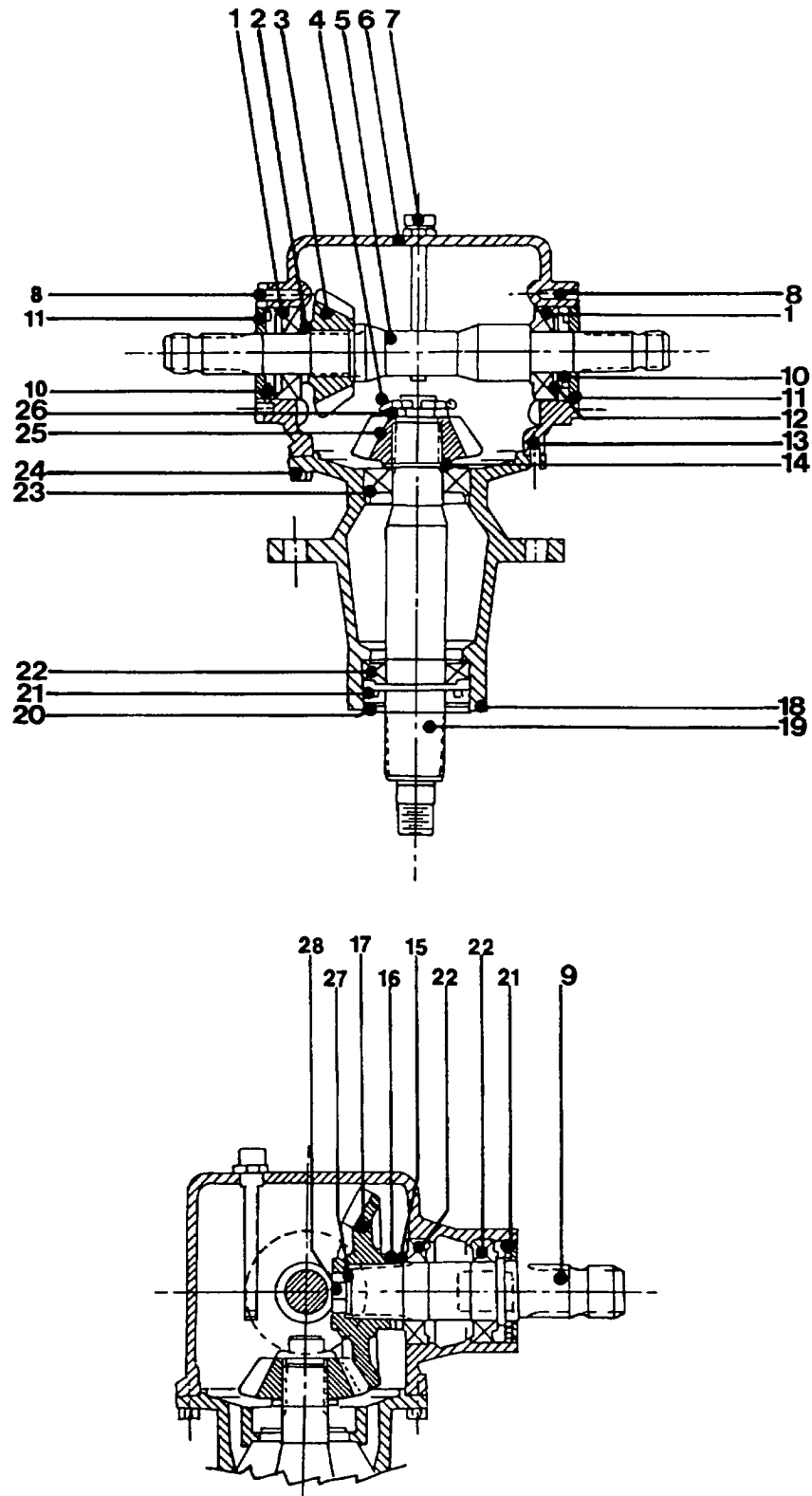

## GEARBOX - CENTER 540 RPM (OFFSET MODEL)

ITEM	PART NO.	QTY.	DESCRIPTION
	<b>00757918</b>	<b>1</b>	<b>GEARBOX ASSEMBLY</b>
1	00758480	2	BEARING CUP & CONE
2	00758481	1	SHIM-BACK GEAR
3	00758482	2	PINION GEAR
4	00001600	1	COTTER PIN
5	00758487	1	SHAFT-CROSS
6	00758483	1	CASING
7	00758484	1	PLUG-VENT
8	00744338	8	BOLT
9	00758495	1	SHAFT-INPUT
10	00758486	2	OIL SEAL
11	00758485	2	COVER - SIDE SHAFT
12	00758488	1	SHIM - CROSS SHAFT
13	00758489	2	SPRING PIN
14	00758490	1	SHIM - LOWER GEAR
15	00758500	1	SHIM - INPUT GEAR
16	00758491	1	SPACER - INPUT GEAR
17	00758499	1	GEAR INPUT
18	00758493	1	EXTENSION LOWER
19	00758492	1	SHAFT - LOWER BLADE
20	00755626	1	PROTECTIVE SHIELD
21	00755627	2	OIL SEAL
22	00755628	3	BEARING
23	00758494	1	BEARING CUP & CONE
24	00751688	8	BOLT
25	00758482	2	PINION GEAR
26	00758496	1	NUT
27	00758498	1	SPRING WASHER
28	00758497	1	LOCKNUT

# GEARBOX MOUNTING (OFFSET MODEL)

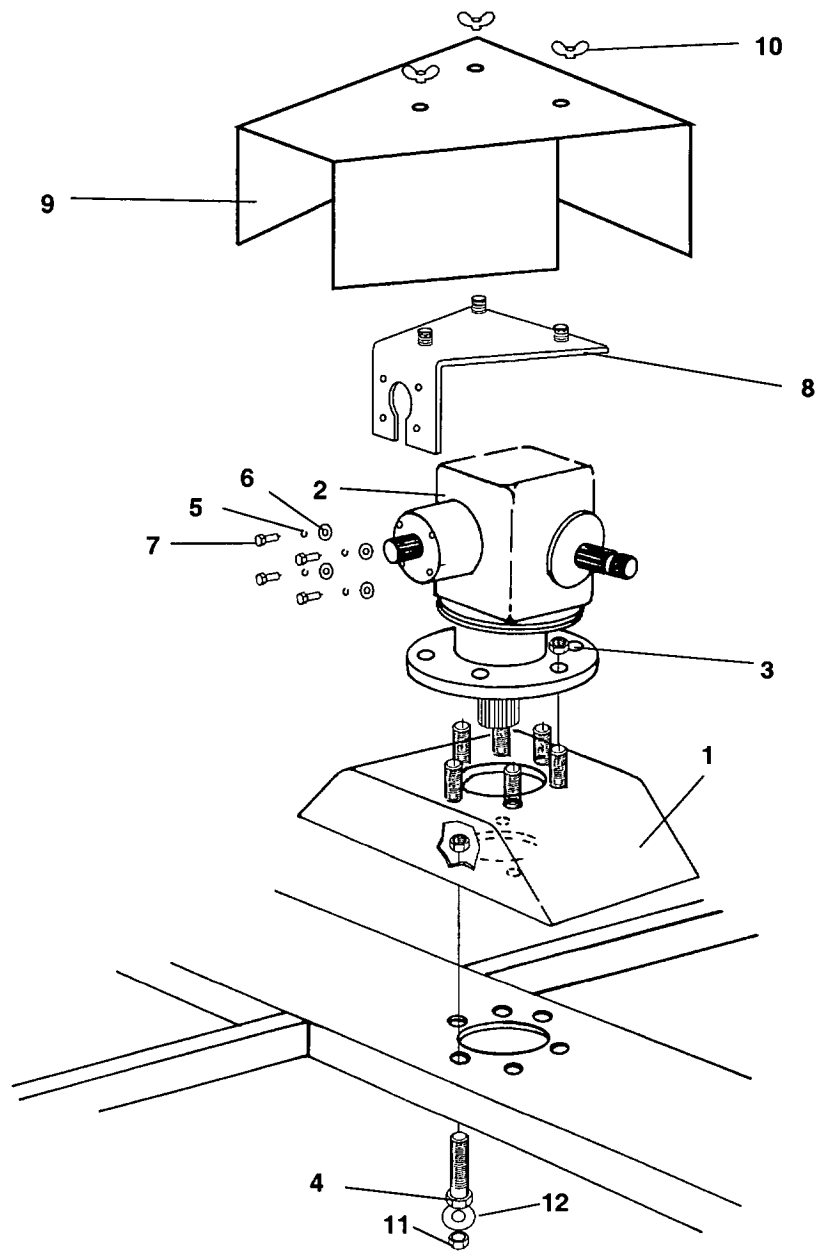

## GEARBOX MOUNTING (OFFSET MODEL)

ITEM	PART NO.	QTY.	DESCRIPTION
1	00767668	1	GEARBOX MOUNT WLD'MT ( S/N 12424 AND ABOVE )
1	00765743	1	GEARBOX MOUNT WLD'MT ( S/N 12423 AND BELOW )
2	00757918	1	GEARBOX
3	00037200	6	NUT
4	02959391	6	BOLT ( NOT REQUIRED S/N 12424 AND ABOVE )
5	00011700	4	LOCKWASHER
6	00023500	4	FLATWASHER
7	02958784	4	BOLT
8	00763919	1	SHIELD BRACKET
9	00763914	1	GEARBOX SHIELD
10	5F8130	3	WING NUT
11	00695100	6	NUT ( S/N 12424 AND ABOVE )
12	00756077	6	WASHER ( S/N 12424 AND ABOVE )

# DRIVELINE COUPLER (OFFSET MODEL)

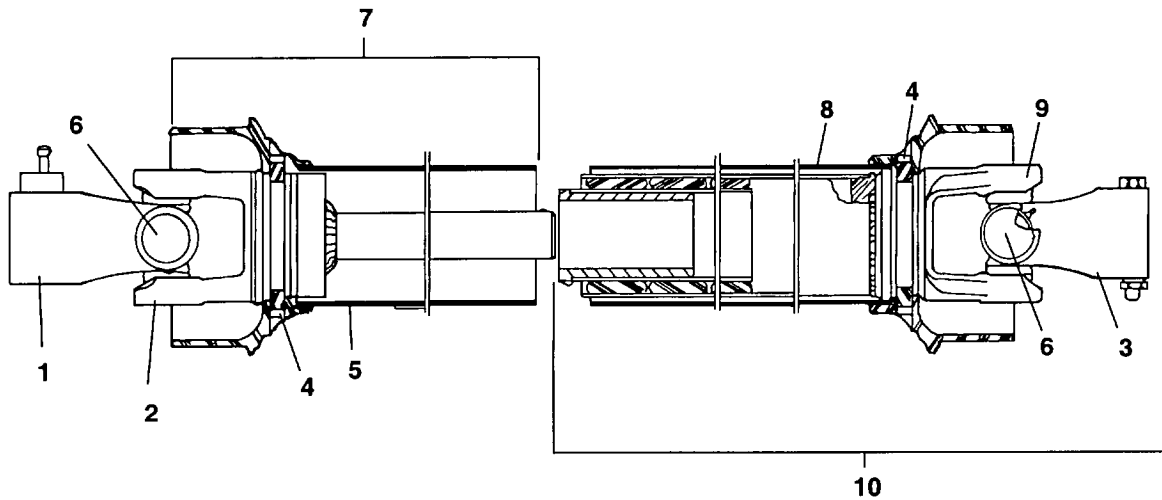

ITEM	PART NO.	QTY.	DESCRIPTION
	<b>00764755</b>	<b>1</b>	<b>DRIVELINE ASY.</b>
1	3066	1	YOKE
2	00758470	1	YOKE AND BAR WLD'MT
3	00758472	1	YOKE
4	00758475	1	SHIELD BEARING
5	00758474	1	OUTER SHIELD TUBE
6	00189700	2	CROSS & BEARING KIT
7	00758468	1	DRIVELINE - BAR HALF
8	00769320	1	INNER SHIELD TUBE
9	00769319	1	YOKE, TUBE & SLEEVE
10	00766442	1	DRIVELINE - INNER HALF

# BLADE PAN ASSEMBLIES (OFFSET MODEL)

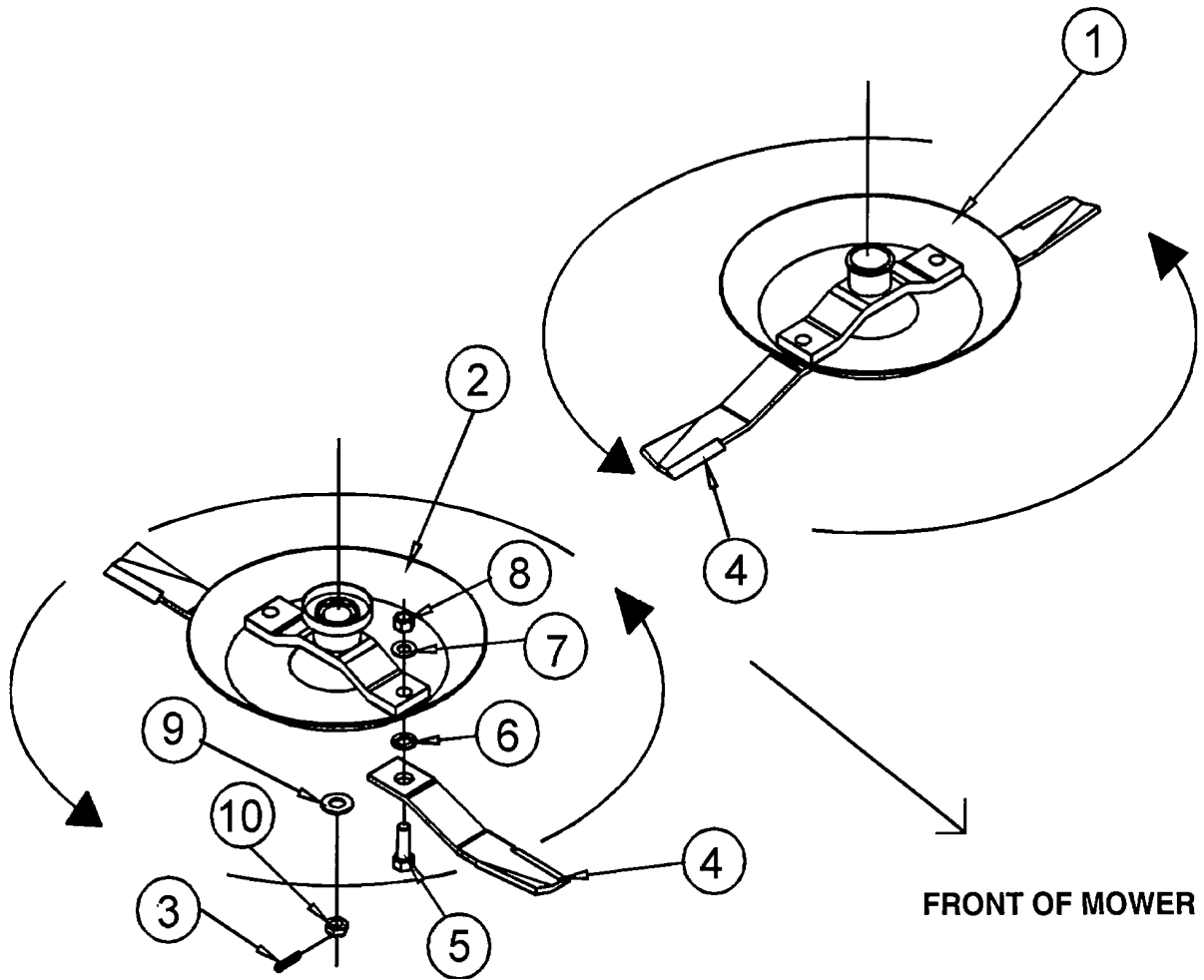

ITEM	PART NO.	QTY.	DESCRIPTION
1	00767670	1	DISHPAN WLD'MT
2	00767672	1	DISHPAN WLD'MT
3	00606000	2	COTTER PIN
4	00753842	4	BLADE, STD SUCTION ( CCW )
	00769609	4	BLADE, HI-LIFT SUCTION (CCW) TWISTED
5	8251	4	BLADE BOLT
6	00758579	4	WASHER BLADE
7	9216	4	WASHER 1" STRUCTURAL
8	5JRC16140	4	LOCKNUT
9	00755623	REF	WASHER
10	00755624	REF	NUT

# JACKSHAFT SUPPORT - PULL TYPE (OFFSET MODEL)

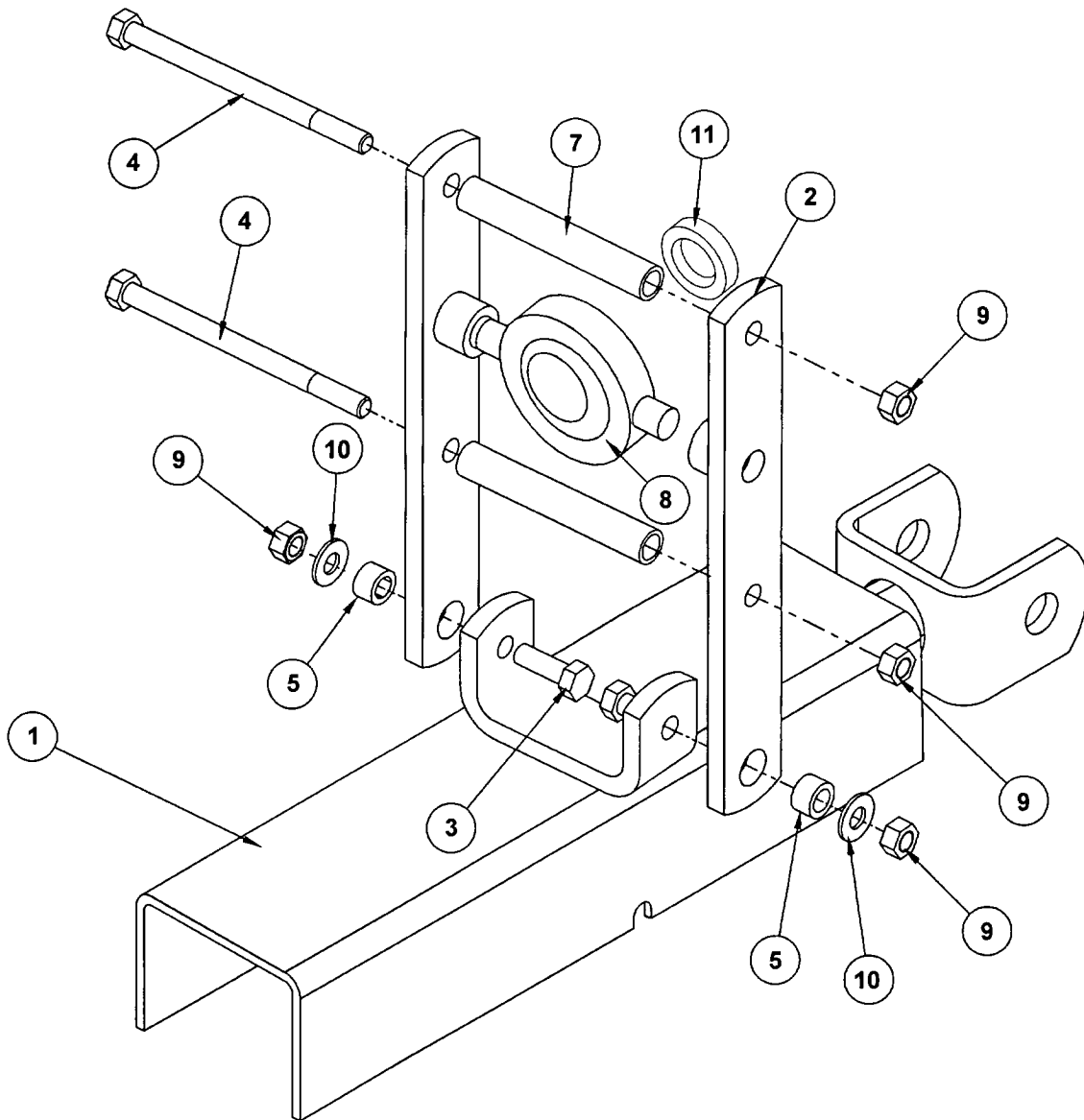

ITEM	PART NO.	QTY.	DESCRIPTION
1	00767629	1	OFFSET TONGUE WLD'MT
2	00767632	2	JACKSHAFT SUPPORT WLD'MT
3	00748823	2	BOLT
4	02963243	2	BOLT
5	681112	2	BUSHING
7	00760943	2	PIPE SPACER
8	00759100	1	BEARING & HOUSING
9	00001800	4	NUT
10	00002700	2	FLATWASHER
11	00768652	1	SPACER

AG96 (April-04) S/N 01605 -Current Rev 09-04

# MOWER SUPPORT ASSEMBLY (OFFSET MODEL)

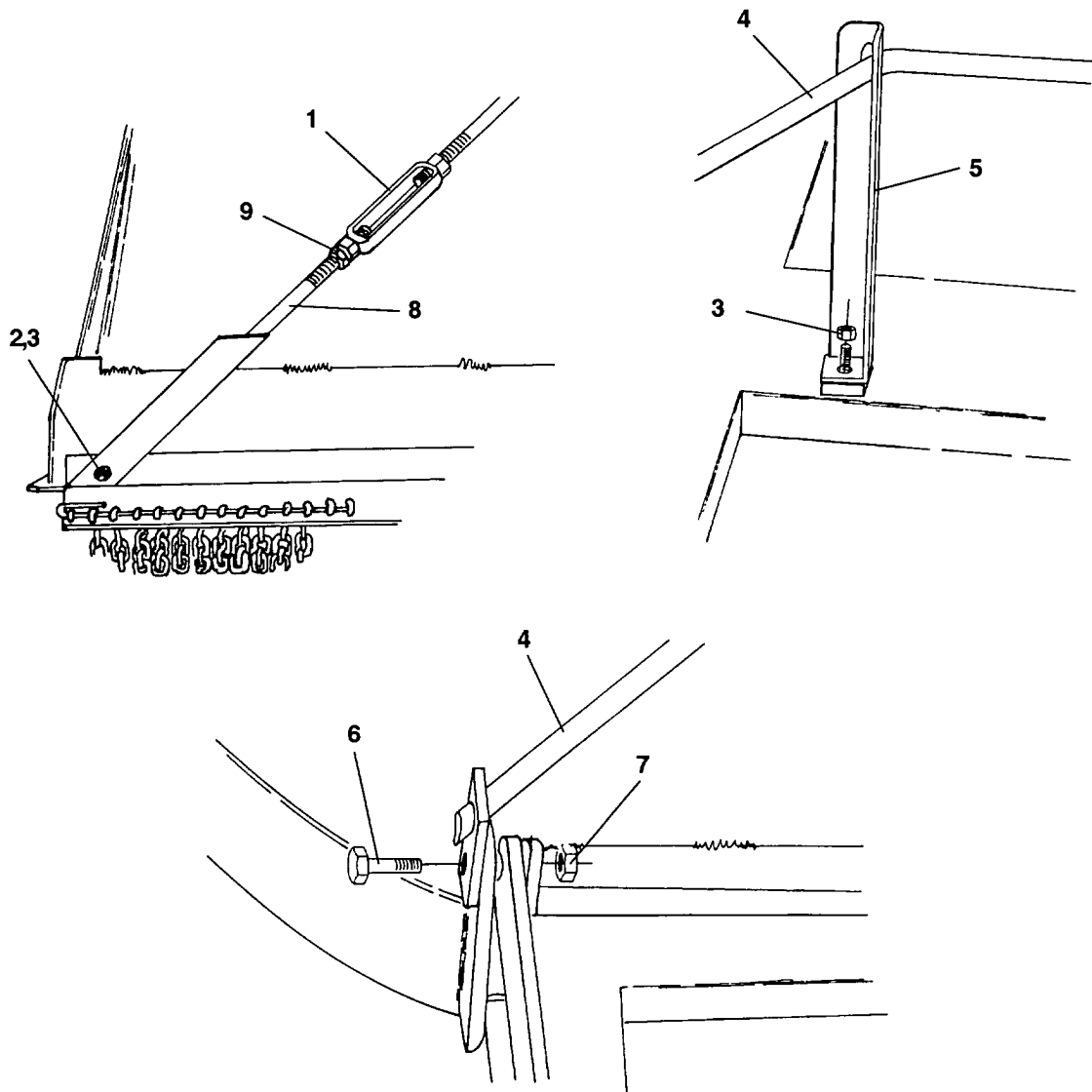

ITEM	PART NO.	QTY.	DESCRIPTION
1	8305	1	TURNBUCKLE BODY
2	02030700	1	BOLT
3	00001800	1	NUT
4	00766334	1	LONG ROD WLD'MT
5	00766331	1	SUPPORT BEAM WLD'MT
6	00007800	1	BOLT
7	00037200	1	NUT
8	00766337	1	SHORT ROD WLD'MT
9	5C1490	1	JAM NUT

# HYDRAULIC OFFSET

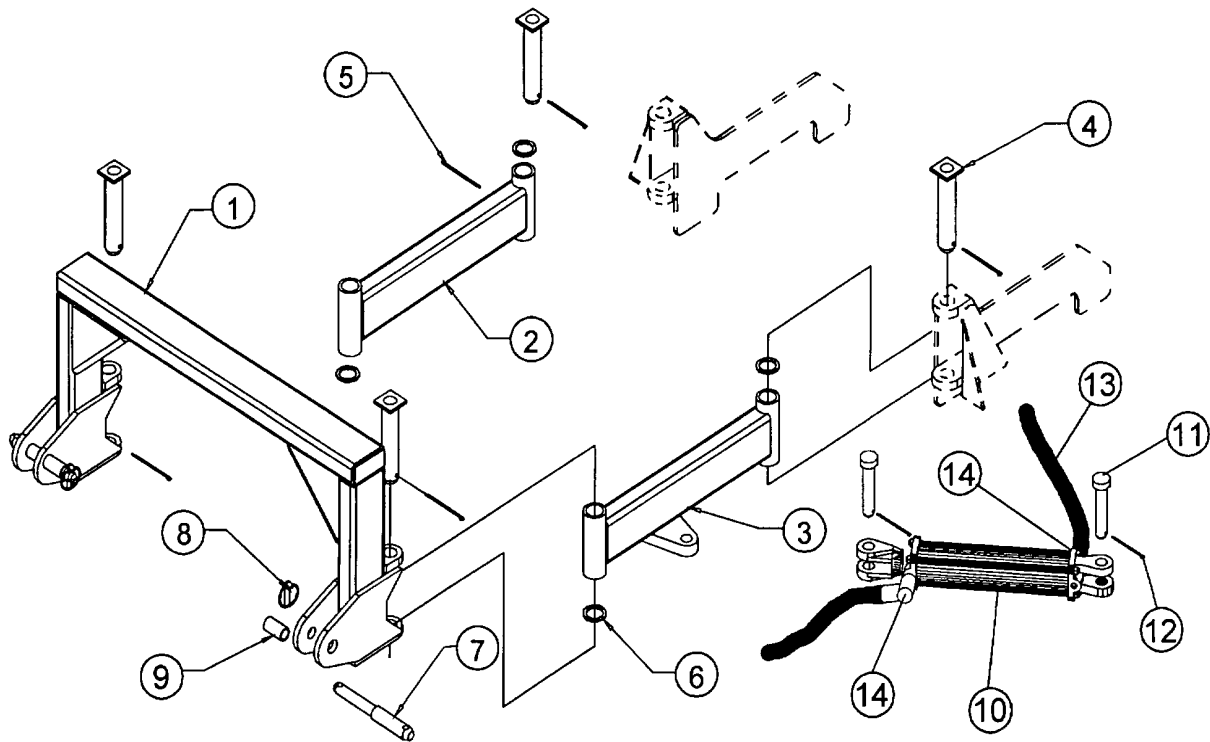

ITEM	PART NO.	QTY.	DESCRIPTION
1	00771344	1	HITCH FRAME WLD'MT
2	00771345	1	SPRING RIGHT ARM WLD'MT
3	00771346	1	SPRING LEFT ARM, W/ LUG WLD'MT
4	00771281	4	PIVOT PINS, W/ WLD'MT
5	01422502	4	COTTER PIN
6	00749941	4	WASHER
7	0781080000	2	HITCH PIN
8	2196	2	LYNCH PIN
9	00772458	2	TUBE SPACER
10	8727	1	CYLINDER
11	8354	2	PIVOT PIN
12	00606000	2	COTTER PIN
13	00755449	2	HOSE
14	104151	2	ADAPTER

# CYLINDER, HYDRAULIC (OPTIONAL)

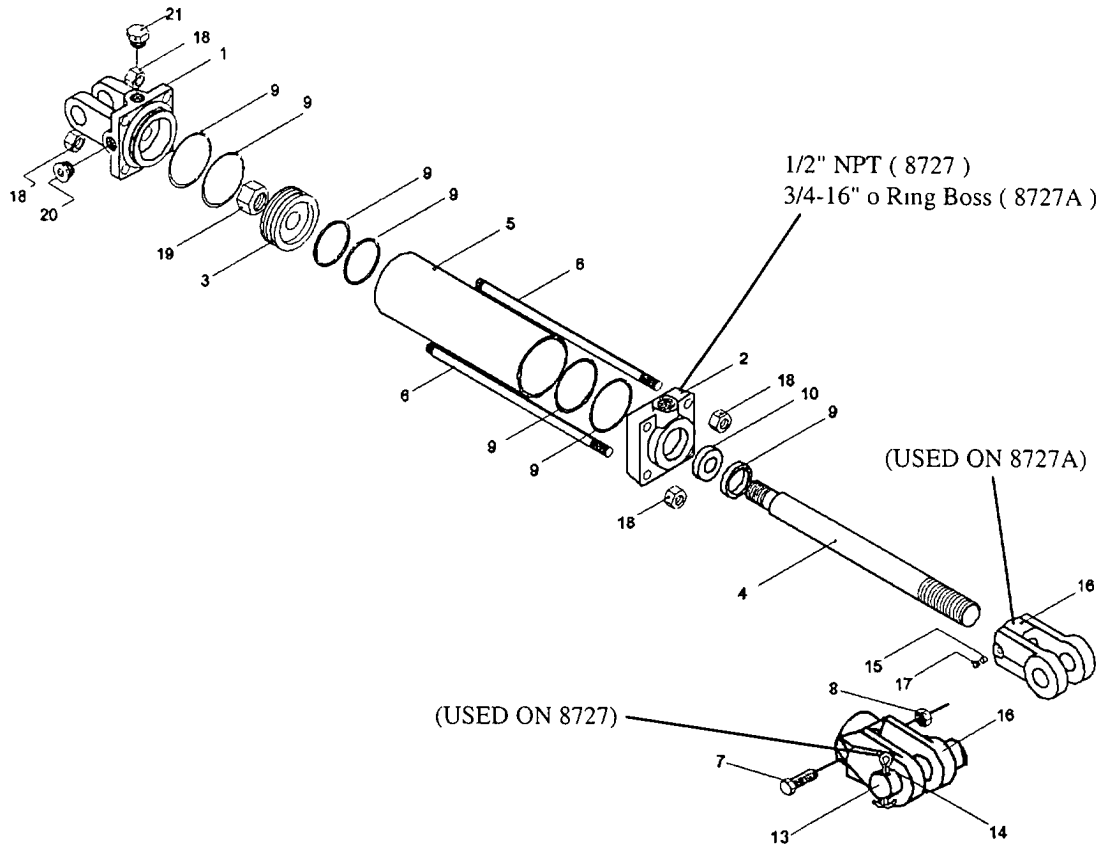

ITEM	PART NO.	QTY.	DESCRIPTION
	<b>8727</b>		<b>CYLINDER ASY.</b>
1	8755	1	CAP
2	8757	1	HEAD
3	00760671	1	PISTON
4	8753	1	PISTON ROD
5	8752	1	TUBE
6	8756	4	TIE ROD
7	00023100	1	BOLT
8	00013901	1	HEX NUT
9	8763	1	SEAL KIT
13	8354	2 ref	PIVOT PIN
14	00606000	2 ref	COTTER PIN
16	8754	1	OUTER CLEVIS
18	02031800	8	TIE ROD NUT
19	4675	1	PISTON NUT
21	7339	1	BREATHER PLUG
	651132	2 ref	HYDRAULIC HOSE ( NOT SHOWN )
	94514	2 ref	SWIVEL FITTING 90-DEGREES ( NOT SHOWN )

# CYLINDER, HYDRAULIC (OPTIONAL)

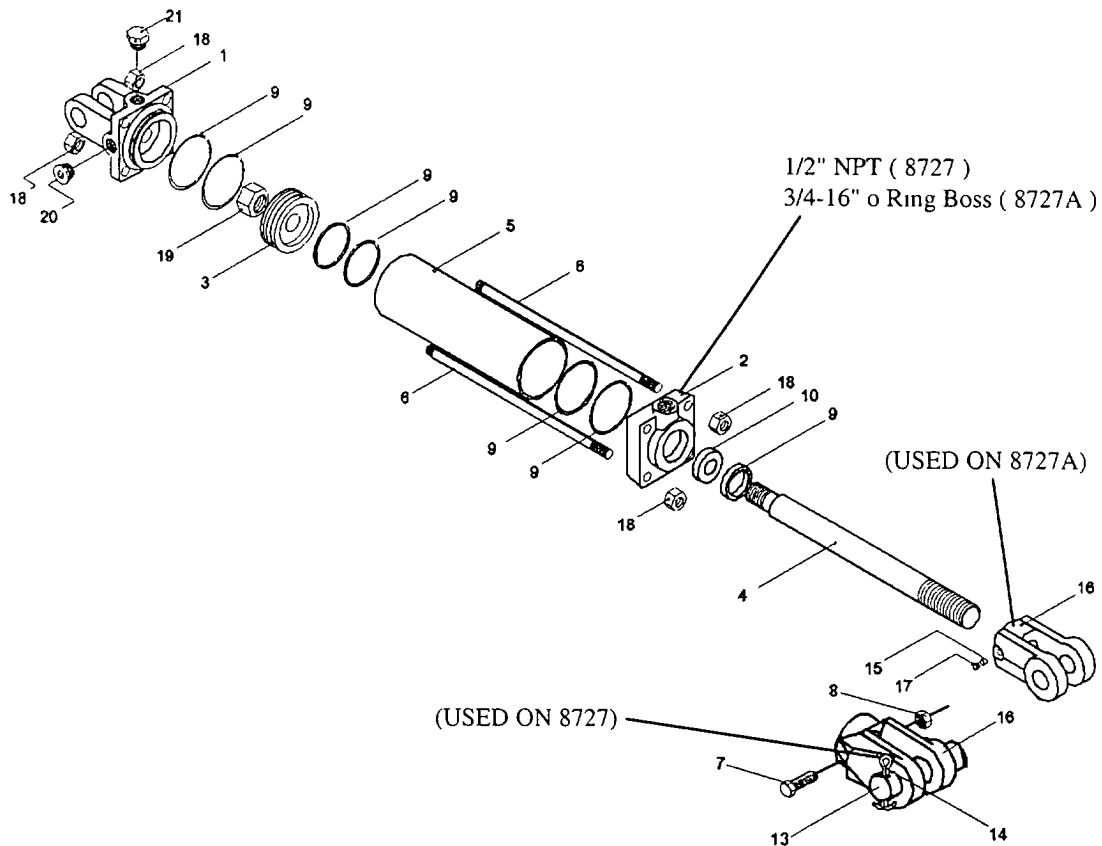

ITEM	PART NO.	QTY.	DESCRIPTION
	<b>8727A</b>		<b>CYLINDER ASY.</b>
1	00774729	1	CLEVIS CAP
2	00774734	1	ROD CAP
3	00774730	1	PISTON
4	00774753	1	ROD
5	3047111	1	TUBE
6	3047112	4	TIE ROD
9	00774760	1	SEAL KIT
15	3047117	1	NYLON THREAD PROTECTOR
16	1917140	1	ROD CLEVIS
17	00774740	1	SET SCREW
18	33003H5C	8	TIE ROD NUT
19	5JRC12160	1	PISTON NUT
20	1917132	1	PORT PLUG
21	2417154	1	BREATHER
	651132	2 ref	HOSE ( NOT SHOWN )
	94514	2 ref	ELBOW ( NOT SHOWN )
	0652141311	2 ref	ADAPTER ( NOT SHOWN )
	8354	2 ref	PIN ( NOT SHOWN )
	00606000	2 ref.	COTTER PIN ( NOT SHOWN )

# NOTE

# OFFSET ADAPTER, THREE-POINT (OPTIONAL)

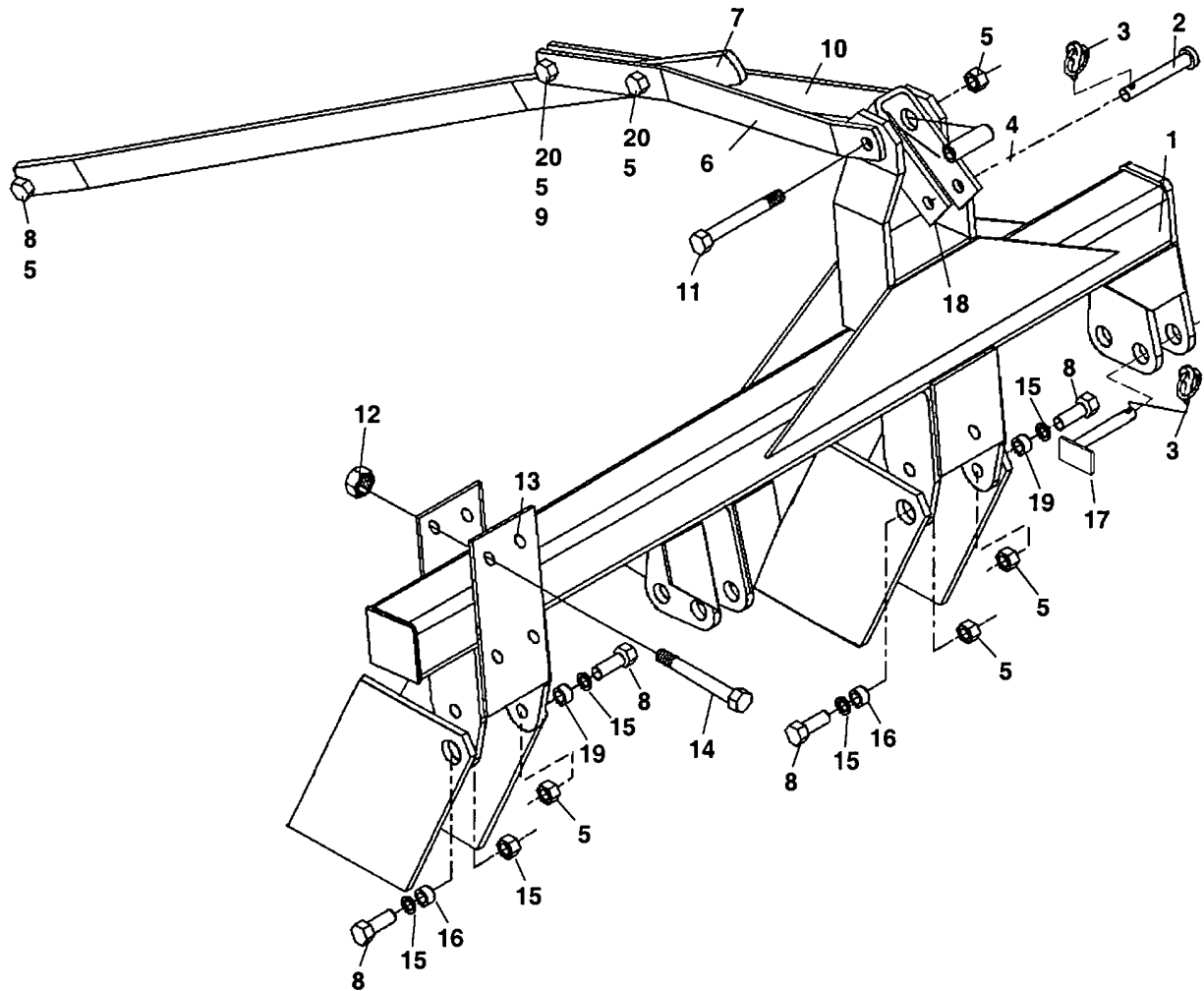

## OFFSET ADAPTER, THREE-POINT (OPTIONAL)

ITEM	PART NO.	QTY.	DESCRIPTION
1	00761610	1	OFFSET ADAPTER WLD'MT
2	3730110M	1	TOPLINK PIN
3	2196	3	CLIP
4	00757953	1	BUSHING
5	00037200	8	NUT
6	00763391	1	FLAT BRACE ( FORMED SHORT )
7	00763392	1	FLAT BRACE ( FORMED LONG )
8	02931300	5	BOLT
9	00762808	1	SPACER
10	00763430	1	FLAT BRACE ( STRAIGHT )
11	02959587	1	BOLT
12	00695100	4	LOCKNUT
13	00761621	1	HITCH LUG WLD'MT
14	00059100	4	BOLT
15	00002701	4	FLATWASHER
16	00761624	2	BUSHING
17	0758440000	2	WRIST PIN WLD'MT
18	00760959	1	FLAT TOP LINK
19	00761625	2	BUSHING
20	02959391	2	BOLT

# AXLE ASSEMBLY (SEMI MOUNT & HYD OFFSET MODELS)

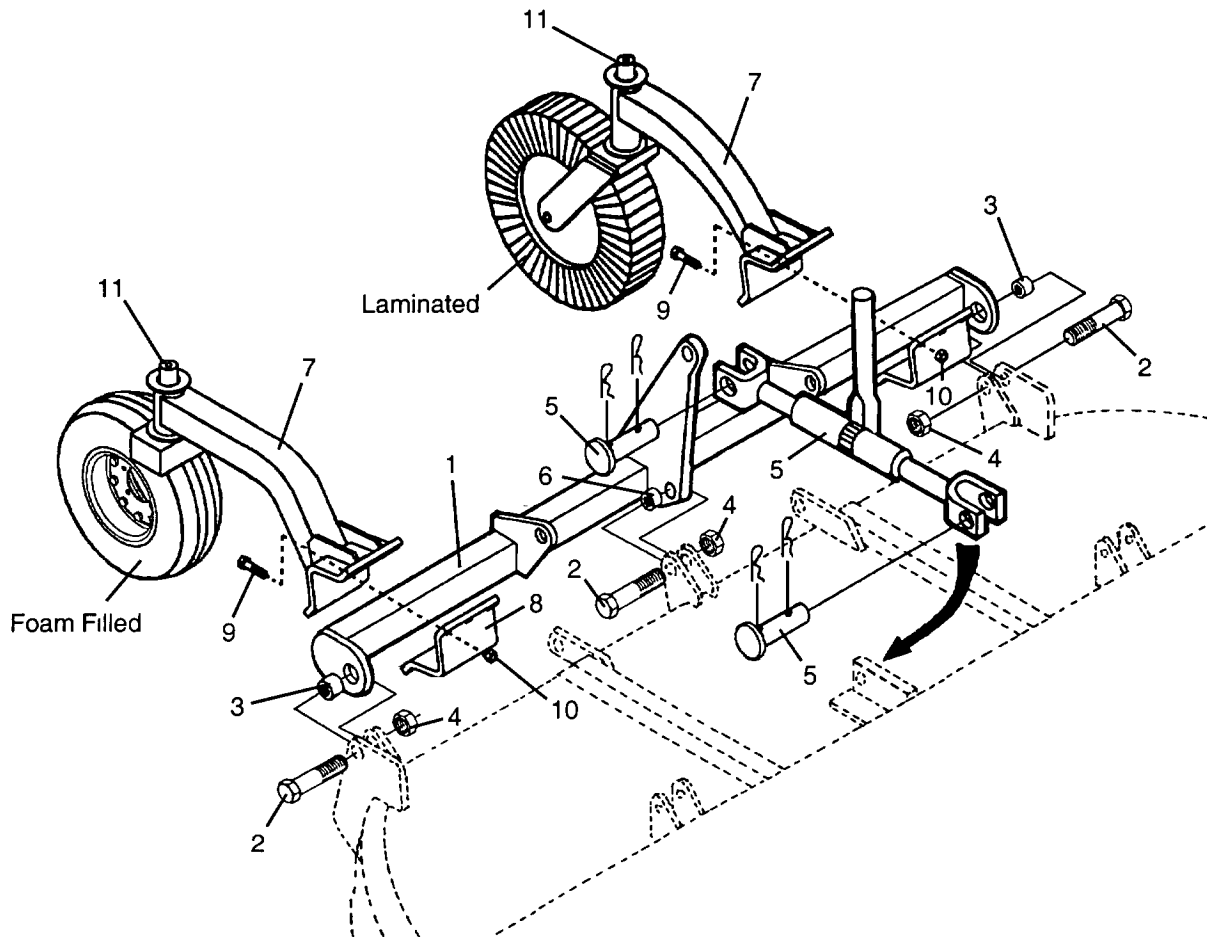

ITEM	PART NO.	QTY.	DESCRIPTION
1	00769692	1	AXLE WLD'MT
2	00007800	3	BOLT
3	00762802	2	BUSHING
4	00037200	3	NUT
5	00554600	1	RATCHET JACK ASY.
6	8327	1	LEVEL ROD BUSHING
7	00769690	2	CASTER ARM ( W/ LAMINATED TIRE )
	00763097	2	CASTER ARM ( W/ FOAM FILLED TIRE )
8	0683030200	2	CAP WLD'MT
9	00750952	12	BOLT
10	02956948	12	NUT
11	0585020200	2	CASTER FORK ( W/ LAMINATED TIRE )
	00758151	2	CASTER FORK ( W/ FOAM FILLED TIRE )

# CASTER ASSEMBLY (AXLE) - FOAM FILLED

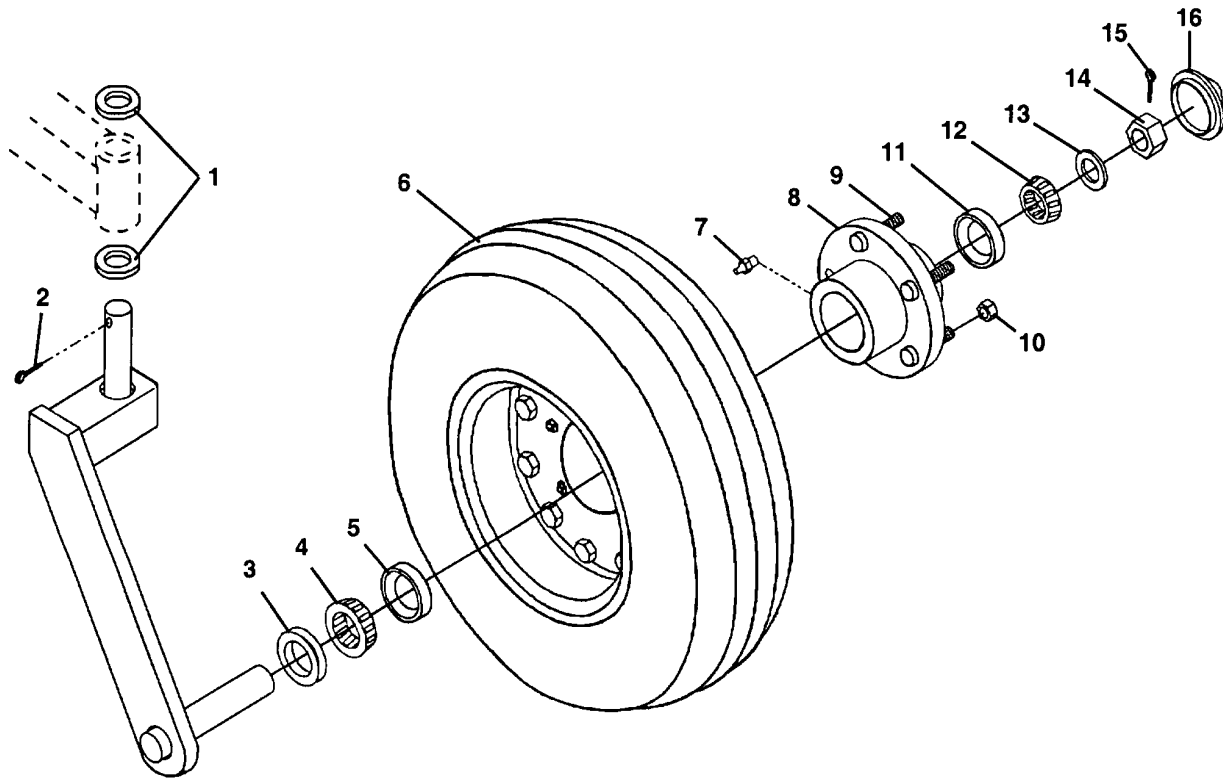

ITEM	PART NO.	QTY.	DESCRIPTION
	<b>00763516</b>	-	<b>COMPLETE CASTER ASY. ( W/ CASTER ARM ) NOT SHOWN</b>
1	00765807	2	WASHER
2	165024	1	COTTER PIN
3	00750616	1	SEAL
4	00750434	1	INSIDE BEARING CONE
5	00756577	1	INSIDE BEARING CUP
6	00766911A	1	AIRCRAFT FOAM FILLED TIRE
7	00003500	1	GREASE FITTING
8	00756489	1	HUB ASY., W/ CUPS & STUDS
9	00752177	5	STUD BOLT
10	00750614	5	NUT
11	00756576	1	OUTSIDE BEARING CUP
12	0371242102	1	OUTSIDE BEARING CONE
13	00756493	1	WASHER
14	00756490	1	SPINDLE NUT
15	00026200	1	COTTER PIN
16	00756492	1	DUST CAP

# TIRE & WHEEL OPTIONS - PULL TYPE

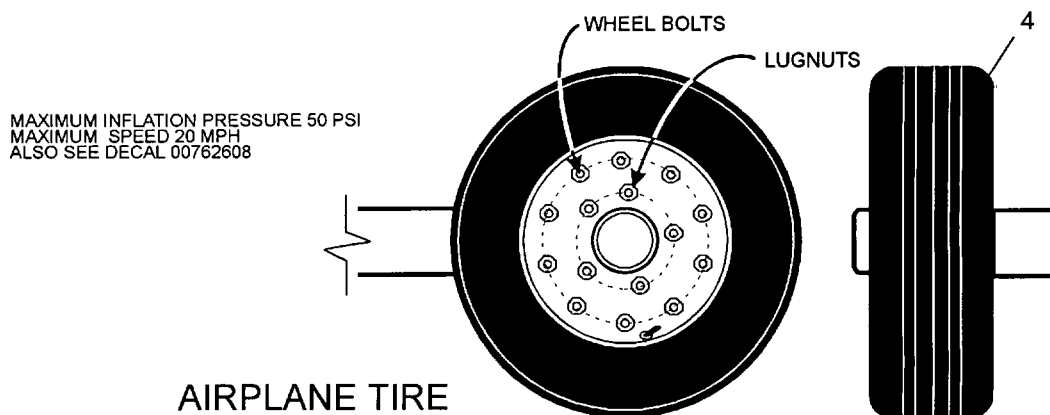
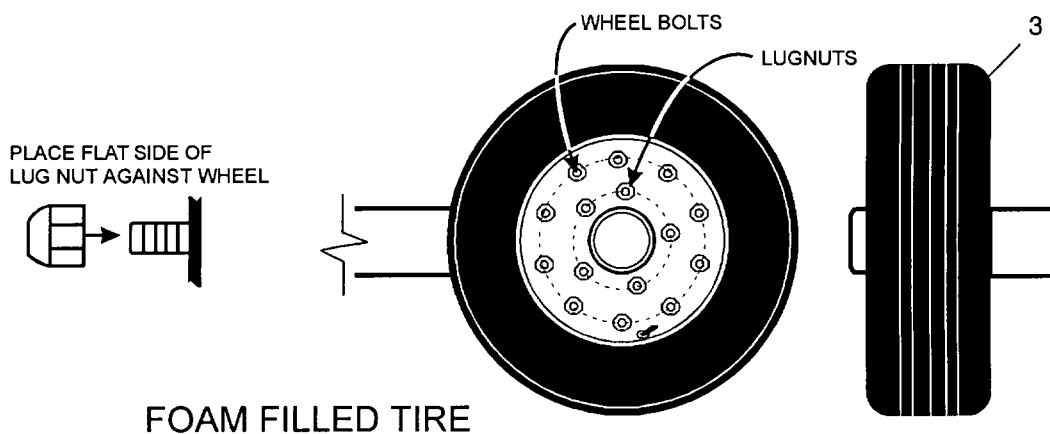
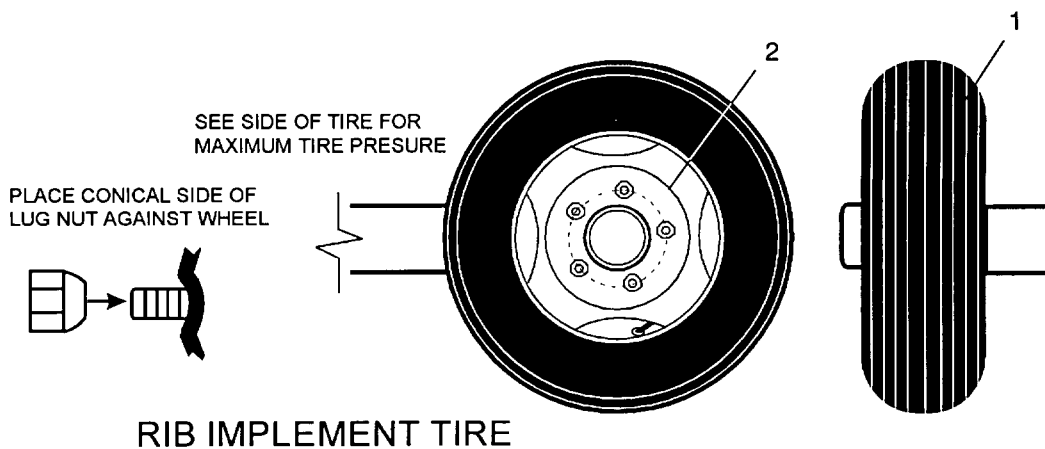

## TIRE & WHEEL OPTIONS - PULL TYPE

ITEM	PART NO.	QTY.	DESCRIPTION
1	00749698	2	IMPLEMENT TIRE ( COMPLETE ASY. )
2	00008700	2	15" RIM
3	00766911A	2	FOAM FILLED AIRPLANE TIRE
4	00771461	2	AIRPLANE TIRE



# ALAMO INDUSTRIAL

## LIMITED WARRANTY

### 1. LIMITED WARRANTIES

- 1.01. Alamo Industrial warrants for one year from the purchase date to the original non-commercial, governmental, or municipal purchaser ("Purchaser") and warrants for six months to the original commercial or industrial purchaser ("Purchaser") that the goods purchased are free from defects in material or workmanship.
- 1.02. Manufacturer will replace for the Purchaser any part or parts found, upon examination at one of its factories, to be defective under normal use and service due to defects in material or workmanship.
- 1.03. This limited warranty does not apply to any part of the goods which has been subjected to improper or abnormal use, negligence, alteration, modification, or accident, damaged due to lack of maintenance or use of wrong fuel, oil, or lubricants, or which has served its normal life. This limited warranty does not apply to any part of any internal combustion engine, or expendable items such as blades, shields, guards, or pneumatic tires except as specifically found in your Operator's Manual.
- 1.04. Except as provided herein, no employee, agent, Dealer, or other person is authorized to give any warranties of any nature on behalf of Manufacturer.

### 2. REMEDIES AND PROCEDURES.

- 2.01. This limited warranty is not effective unless the Purchaser returns the Registration and Warranty Form to Manufacturer within 30 days of purchase.
- 2.02. Purchaser claims must be made in writing to the Authorized Dealer ("Dealer") from whom Purchaser purchased the goods or an approved Authorized Dealer ("Dealer") within 30 days after Purchaser learns of the facts on which the claim is based.
- 2.03. Purchaser is responsible for returning the goods in question to the Dealer.
- 2.04. If after examining the goods and/or parts in question, Manufacturer finds them to be defective under normal use and service due to defects in material or workmanship, Manufacturer will:
  - (a) Repair or replace the defective goods or part(s) or
  - (b) Reimburse Purchaser for the cost of the part(s) and reasonable labor charges (as determined by Manufacturer) if Purchaser paid for the repair and/or replacement prior to the final determination of applicability of the warranty by Manufacturer.The choice of remedy shall belong to Manufacturer.
- 2.05. Purchaser is responsible for any labor charges exceeding a reasonable amount as determined by Manufacturer and for returning the goods to the Dealer, whether or not the claim is approved. Purchaser is responsible for the transportation cost for the goods or part(s) from the Dealer to the designated factory.

### 3. LIMITATION OF LIABILITY.

- 3.01. MANUFACTURER DISCLAIMS ANY EXPRESS (EXCEPT AS SET FORTH HEREIN) AND IMPLIED WARRANTIES WITH RESPECT TO THE GOODS INCLUDING, BUT NOT LIMITED TO, MERCHANTABILITY AND FITNESS FOR A PARTICULAR PURPOSE.
- 3.02. MANUFACTURER MAKES NO WARRANTY AS TO THE DESIGN, CAPABILITY, CAPACITY, OR SUITABILITY FOR USE OF THE GOODS.
- 3.03. EXCEPT AS PROVIDED HEREIN, MANUFACTURER SHALL HAVE NO LIABILITY OR RESPONSIBILITY TO PURCHASER OR ANY OTHER PERSON OR ENTITY WITH RESPECT TO ANY LIABILITY, LOSS, OR DAMAGE CAUSED OR ALLEGED TO BE CAUSED DIRECTLY OR INDIRECTLY BY THE GOODS INCLUDING, BUT NOT LIMITED TO, ANY INDIRECT, SPECIAL, CONSEQUENTIAL, OR INCIDENTAL DAMAGES RESULTING FROM THE USE OR OPERATION OF THE GOODS OR ANY BREACH OF THIS WARRANTY. NOT WITHSTANDING THE ABOVE LIMITATIONS AND WARRANTIES, MANUFACTURER'S LIABILITY HEREUNDER FOR DAMAGES INCURRED BY PURCHASER OR OTHERS SHALL NOT EXCEED THE PRICE OF THE GOODS.
- 3.04. NO ACTION ARISING OUT OF ANY CLAIMED BREACH OF THIS WARRANTY OR TRANSACTIONS UNDER THIS WARRANTY MAY BE BROUGHT MORE THAN TWO (2) YEARS AFTER THE CAUSE OF ACTION HAS OCCURRED.

### 4. MISCELLANEOUS.

- 4.01. Proper Venue for any lawsuits arising from or related to this limited warranty shall be only in Guadalupe County, Texas.
- 4.02. Manufacturer may waive compliance with any of the terms of this limited warranty, but no waiver of any terms shall be deemed to be a waiver of any other term.
- 4.03. If any provision of this limited warranty shall violate any applicable law and is held to be unenforceable, then the invalidity of such provision shall not invalidate any other provisions herein.
- 4.04. Applicable law may provide rights and benefits to purchaser in addition to those provided herein.

### KEEP FOR YOUR RECORDS

ATTENTION: Purchaser should fill in the blanks below for his reference when buying repair parts and/or for proper machine identification when applying for warranty.

Alamo Industrial Implement Model \_\_\_\_\_ Serial Number \_\_\_\_\_

Date Purchased \_\_\_\_\_ Dealer \_\_\_\_\_

ATTENTION:  
READ YOUR OPERATOR'S MANUAL

**ALAMO INDUSTRIAL**

An Alamo Group Company  
1502 E. Walnut  
Seguin, Texas 78155  
830-379-1480





## TO THE OWNER/OPERATOR/DEALER

To keep your implement running efficiently and safely, read your manual thoroughly and follow these directions and the Safety Messages in this Manual. The Table of Contents clearly identifies each section where you can easily find the information you need.

The OCCUPATIONAL SAFETY AND HEALTH ACT (1928.51 Subpart C) makes these minimum safety requirements of tractor operators:

### REQUIRED OF THE OWNER:

1. Provide a Roll-Over-Protective Structure that meets the requirements of this Standard; and
2. Provide Seatbelts that meet the requirements of this paragraph of this Standard and SAE J4C; and
3. Ensure that each employee uses such Seatbelt while the tractor is moving; and
4. Ensure that each employee tightens the Seatbelt sufficiently to confine the employee to the protected area provided by the ROPS.

### REQUIRED OF THE OPERATOR

1. Securely fasten seatbelt if the tractor has a ROPS.
2. Where possible, avoid operating the tractor near ditches, embankments, and holes.
3. Reduce speed when turning, crossing slopes, and on rough, slick, or muddy surfaces.
4. Stay off slopes too steep for safe operation.
5. Watch where you are going - especially at row ends, on roads, and around trees.
6. Do not permit others to ride.
7. Operate the tractor smoothly - no jerky turns, starts, or stops.
8. Hitch only to the drawbar and hitch points recommended by the tractor manufacturer.
9. When the tractor is stopped, set brakes securely and use park lock, if available.

- 
- Keep children away from danger all day, every day...**
  - Equip tractors with rollover protection (ROPS) and keep all machinery guards in place...**
  - Please work, drive, play and live each day with care and concern for your safety and that of your family and fellow citizens.**



