

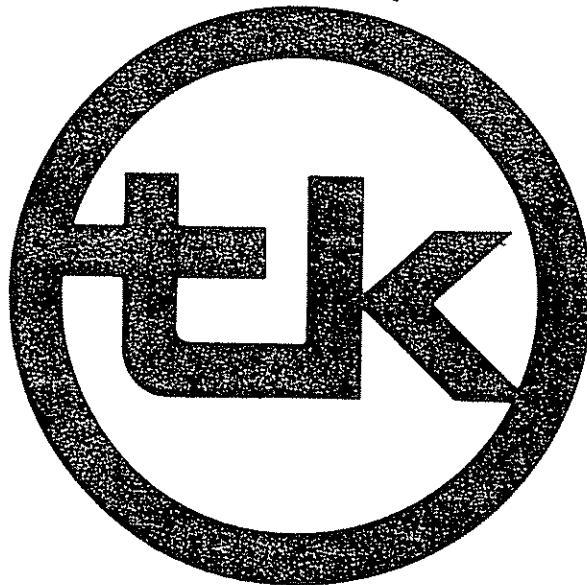

Alamo Group

# TK-101

## OWNER'S MANUAL AND PARTS LIST



# TERRAIN KING CORPORATION

P.O. DRAWER 549 SEGUIN, TEXAS 78156-0549 Phone (512) 379-1480

This Parts Manual is specially made for the following unit.  
T.101\_\_\_\_\_/10-86 Serial No.\_\_\_\_\_  
Dealer/Customer\_\_\_\_\_

# TABLE OF CONTENTS

WARRANTY.....	2
OPERATION SAFEGUARDS.....	3,4
OPERATION INSTRUCTIONS.....	5,6
PRE-OPERATION CHECKS, LUBRICATIONS, MAINTENANCE.....	7
SLIP CLUTCHES, CUTTING SYSTEM.....	8
DISASSEMBLY OF SIDE GEARBOX, ASSEMBLY OF SIDE GEARBOX.....	9
DISASSEMBLY OF CENTER GEARBOX, ASSEMBLY OF CENTER GEARBOX....	10
INSTRUCTIONS FOR ORDERING PARTS.....	11
ASSEMBLY INSTRUCTIONS FOR LIFT MODEL.....	12
ASSEMBLY INSTRUCTIONS FOR PULL MODEL.....	13

## PARTS LIST

BASE ASSEMBLY - LIFT MODEL.....	14,15
BASE ASSEMBLY - PULL MODEL.....	16
BLADE BAR ASSEMBLY - LIFT & PULL MODEL.....	17
CENTER GEARBOX ASSEMBLY - LIFT & PULL MODEL.....	18,19
SIDE GEARBOX ASSEMBLY - LIFT & PULL MODEL.....	20,21
RIGHT HAND FLEXIBLE COUPLING - LIFT & PULL MODEL.....	22
LEFT HAND FLEXIBLE COUPLING - LIFT & PULL MODEL.....	23
DRIVESHAFT ASSEMBLY - LIFT MODEL.....	24
DRIVESHAFT ASSEMBLY - PULL MODEL.....	25
SLIP CLUTCH - LIFT & PULL MODEL.....	26
SAFETY SHIELD ASSEMBLY - LIFT & PULL MODEL.....	27
"A" FRAME ASSEMBLY - LIFT MODEL.....	28
TAILWHEEL ASSEMBLY - LIFT MODEL.....	29
TONGUE ASSEMBLY - PULL MODEL.....	30
SHOCK ABSORBER ASSEMBLY - PULL MODEL.....	31
AXLE ASSEMBLY - PULL MODEL.....	32
HUB AND BEARING GROUP - PULL MODEL.....	33
RATCHET JACK ASSEMBLY - PULL MODEL.....	34

## OPTIONS

ROUND BLADE HOLDER ASSEMBLY - LIFT & PULL MODEL.....	35
CHAIN GUARD ASSEMBLIES - LIFT & PULL MODEL.....	36

TK-101 PARTS BOOK PART NUMBERT 00754860 PUBLISHED OCTOBER 1986

# WARRANTY

WITHIN A PERIOD OF 1 YEAR FROM PURCHASE DATE, TERRAIN KING CORPORATION WILL REPLACE FOR THE ORIGINAL PURCHASER, FREE OF CHARGES, ANY PART OR PARTS FOUND, UPON EXAMINATION AT OUR FACTORY AT SEGUIN, TEXAS, TO BE DEFECTIVE UNDER NORMAL USE AND SERVICE DUE TO DEFECTS IN MATERIAL OR WORKMANSHIP.

THE WARRANTY SHALL NOT APPLY TO ANY PART OF THE PRODUCT WHICH HAS BEEN SUBJECTED TO MISUSE, NEGLIGENCE, ALTERATION, OR ACCIDENT. THIS WARRANTY DOES NOT APPLY TO UNIVERSAL JOINTS OR TO EXPENDABLE ITEMS SUCH AS BLADES.

THE WARRANTY IS NOT EFFECTIVE UNLESS THE WARRANTY CARD IS RETURNED TO TERRAIN KING CORPORATION WITHIN 14 DAYS OF PURCHASE. CLAIMS MUST BE FILED WITHIN 30 DAYS OF THE FAILURE. WRITTEN PERMISSION MUST BE OBTAINED TO RETURN ITEMS FOR WARRANTY CONSIDERATION. A PACKING LIST MUST ACCOMPANY EACH SHIPMENT GIVING MODEL NUMBER, SERIAL NUMBER, DATE OF SALE, HOURS OR TIME IN OPERATION, DEALER'S NAME, CUSTOMER'S NAME, AND EVENTS LEADING TO THE FAILURE.

# SAFEGUARDS

THE FOLLOWING IS A LIST OF SAFEGUARDS WHICH SHOULD BE FOLLOWED.

1. ROTARY CUTTERS ARE CAPABLE OF THROWING OBJECTS FOR GREAT DISTANCES AND INFLECTING SERIOUS INJURY. NO BYSTANDER SHOULD BE ALLOWED WITHIN A 100 YARD RADIUS OF THE MACHINE IN OPERATION.
2. EXTREME CARE SHOULD BE TAKEN WHEN OPERATING NEAR LOOSE OBJECTS SUCH AS GRAVEL, ROCKS AND DEBRIS. THESE OBJECTS SHOULD BE AVOIDED.
3. THE ROTATING PARTS OF THIS MACHINE HAVE BEEN DESIGNED AND TESTED FOR RUGGED USE. HOWEVER, THEY COULD FAIL UPON IMPACT WITH HEAVY SOLID OBJECTS SUCH AS STEEL GUARD RAILS, CONCRETE ABUTMENTS, ETC., CAUSING THEM TO BE THROWN AT VERY HIGH VELOCITIES. NEVER ALLOW THE CUTTING BLADES TO CONTACT SUCH OBSTACLES.
4. THE OPERATOR AND ALL SUPPORT PERSONNEL SHOULD WEAR "HARD HATS" AND "SAFETY GLASSES" AT ALL TIMES TO PROTECT THEM AGAINST FALLING OBJECTS AND ITEMS THROWN BY THE MACHINE.
5. THE ROTATING PARTS OF THIS MACHINE CONTINUE TO ROTATE EVEN AFTER THE PTO HAS BEEN TURNED OFF. THE OPERATOR SHOULD REMAIN IN HIS SEAT FOR 60 SECONDS AFTER THE TRACTOR HAS BEEN TURNED OFF. THIS WILL ALLOW ENOUGH TIME FOR THE ROTATING MEMBERS TO COME TO REST.
6. OBJECTS SUCH AS WIRE, CABLE, ROPE, CHAINS, ETC., CAN BECOME ENTANGLED IN THE ROTATING PARTS OF THE HEAD. THESE ITEMS COULD THEN SWING OUTSIDE THE HOUSING AT GREATER VELOCITIES THAN THE BLADES, CREATING AN EXTREMELY DANGEROUS CONDITION. INSPECT THE CUTTING AREA FOR SUCH OBJECTS PRIOR TO MOWING. NEVER ALLOW THE CUTTING BLADES TO CONTACT SUCH ITEMS.



## **DANGER**

**THIS EQUIPMENT IS EXTREMELY DANGEROUS!**  
**SERIOUS INJURY OR DEATH MAY OCCUR UNLESS CARE**  
**IS TAKEN TO INSURE THE SAFETY OF BOTH THE**  
**OPERATOR AND ANY OTHER PERSONS IN THE AREA.**

7. THE HITCH SHOULD BE EXAMINED DAILY FOR SIGNS OF WEAR OR BROKEN PARTS. A HITCH FAILURE COULD ALLOW THE MACHINE TO SEPARATE FROM THE TRACTOR AND CREATE A HAZARDOUS SITUATION.
8. TRANSPORT MOWER AT SAFE SPEEDS (10 MPH MAXIMUM). USE FLASHING WARNING LIGHTS WHEN TOWING MACHINE ALONG HIGHWAYS. NEVER ALLOW RIDERS ON MOWER OR TRACTOR.
9. INSPECT THE ENTIRE MACHINE ONCE A WEEK FOR LOOSE BOLTS, WORN OR BROKEN PARTS, ETC. SERIOUS INJURY MAY OCCUR FROM NOT MAINTAINING THIS MACHINE IN GOOD WORKING ORDER.
10. IF OPTIONAL CHAINGUARDS ARE USED, THEY SHOULD BE MAINTAINED IN PROPER WORKING ORDER. THE CHAINGUARDS SHOULD BE CHECKED ONCE A WEEK FOR MISSING CABLE OR CHAIN LINKS. THE MISSING ITEMS SHOULD BE REPLACED.
11. FRONT END WEIGHT SHOULD BE ADDED TO THE TRACTOR TO MAINTAIN ENOUGH WEIGHT ON THE FRONT WHEELS FOR SAFE STEERING. WHEN YOU ADD A HEAVY MOWER ON THE THREE POINT LIFT ARMS OF THE TRACTOR, THE FRONT END OF THE TRACTOR MAY BECOME LIGHT AND LIFT OFF THE GROUND.

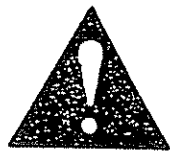

# CAUTION

Failure to follow safe operating practices can cause tractors to rear up which can cause equipment damage and bodily injury.

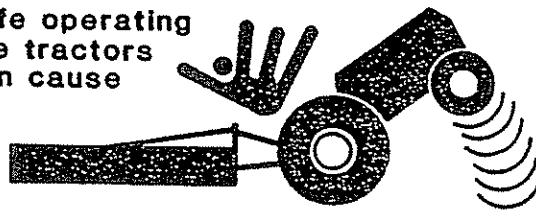

- |   |  |
|---|--|
| 1. MAKE CERTAIN THAT LOCK PINS ARE INSTALLED INTO UPPER AND LOWER LINK PINS ON HITCH.             | 4. NEVER START OR ACCELERATE SUDDENLY TO MAINTAIN SAFE STEERAGE WEIGHT.    |
| 2. ADD FRONT END WEIGHTS AS REQUIRED TO MAINTAIN ENOUGH WEIGHT ON FRONT WHEELS FOR SAFE STEERING. | 5. DO NOT LIFT HEAVY IMPLEMENTS GOING UP STEEP SLOPES.                     |
| 3. SLOW DOWN IN CURVES AND IN ROUGH PLACES TO MAINTAIN SAFE STEERAGE WEIGHT ON FRONT WHEELS.      | 6. DO NOT LIFT IMPLEMENT HEAVIER THAN RECOMMENDED BY TRACTOR MANUFACTURER. |

12. THIS IS ONLY A PARTIAL LIST OF SAFETY PRECAUTIONS TO FOLLOW. PERHAPS THE BEST GENERAL RULE TO FOLLOW IS ALWAYS TO STAY ALERT, USE COMMON SENSE AND MAINTAIN AN AWARENESS OF THE DANGERS INVOLVED IN OPERATING THIS TYPE OF EQUIPMENT.

# OPERATION INSTRUCTIONS

THE TK-101 TERRAIN KING MOWER WAS DESIGNED TO FILL YOUR MOWING NEEDS AND WAS BUILT TO GIVE YOU THE UTMOST IN LONG LIFE AND TROUBLE-FREE SERVICE. FOR BEST RESULTS, PLEASE OBSERVE THE SUGGESTIONS AND PRECAUTIONS GIVEN BELOW:

1. ENGAGE PTO SHAFT AT A LOW ENGINE RPM AND SPEED ENGINE UP AFTER BLADES ARE FULLY ENGAGED. NEVER ENGAGE PTO SHAFT AT A HIGH ENGINE RPM. THIS COULD CAUSE DAMAGE TO THE PTO SHAFT AS WELL AS THE DRIVESHAFTS.
2. ALWAYS RUN THE MACHINE AT THE HIGHEST POSITION WHICH WILL ENABLE YOU TO OBTAIN THE DESIRED CUTTING RESULTS. ALLOWING THE BLADES TO CUT INTO THE GROUND WILL CAUSE WEAR AND UNDUE STRAIN ON THE MOWER FRAME AND MOWER COMPONENTS.
3. IF YOU ARE MOWING IN CONDITIONS OF HEAVY GROWTH OR ROUGH GROUND WHERE THE BLADES CUT INTO THE GROUND AND THE TRACTOR ENGINE SLOWS DOWN, DO NOT SLIP THE CLUTCH TO ALLOW THE ENGINE TO SPEED UP AND ENGAGE THE CLUTCH AGAIN. THIS PROCEDURE EXERTS TREMENDOUS STRAIN ON THE DRIVELINE OF THE TRACTOR AND MOWER. ALWAYS DISENGAGE THE POWER TAKE-OFF AND MOVE FORWARD OR BACKWARD UNTIL THE MACHINE IS CLEAR.
4. THE TK-101 ROTARY MOWER IS DESIGNED WITH FREE SWINGING BLADES. THIS FEATURE REDUCES THE AMOUNT OF SHOCK TRANSMITTED TO OTHER COMPONENTS. ALWAYS MAKE SURE THE BLADE CAN SWING FREELY ON THE BLADE BAR.
5. THE MOWER SHOULD BE OPERATED AT AN ENGINE SPEED THAT TURNS THE PTO AT 540 RPM. THE MOWER IS DESIGNED TO RUN AT THAT SPEED. HIGHER OR LOWER PTO SPEED CAN INCREASE THE LOAD ON THE DRIVESHAFTS AND CLUTCH AND CAUSE PREMATURE FAILURE OF THE DRIVE-LINE. ALWAYS RUN THE TRACTOR AT A SPEED TO GIVE 540 RPM, PTO SPEED.
6. THE STANDARD THREE-POINT LIFT MOWER IS EQUIPPED WITH CATEGORY I SYSTEM BY CHANGING THESE PINS. FRONT END WEIGHTS WILL BE NEEDED TO OPERATE THIS MOWER ON SOME TRACTORS.

7. WHEN CUTTING FOLIAGE AND FINE SHREDDING IS DESIRED, RUN THE MOWER, LEVEL OR SLIGHTLY LOWER IN THE REAR SO AS TO KEEP THE MATERIAL IN THE MOWER UNTIL IT IS SHREDDED. THIS WILL REQUIRE MORE POWER BUT WILL SHRED BETTER. WHEN CUTTING HEAVY FOLIAGE AND FINE SHREDDING IS NOT DESIRED, RAISE THE REAR OF THE MOWER. THIS ALLOWS THE HIGH VOLUME OF MATERIAL TO BE DISCHARGED THUS REQUIRING MUCH LESS POWER.
8. THE TONGUE ON THE MACHINE IS DESIGNED TO HAVE A TURNING RADIUS AS SMALL AS POSSIBLE. SEVERAL FACTORS INCLUDING TIRE SIZE, REAR TIRE SPACING, FRONT TIRE SPACING, AND DRAWBAR LENGTH ALL AFFECT THE TURNING RADIUS. BY BRINGING THE FRONT AND REAR TIRES CLOSER INTO THE TRACTOR, THE TURNING RADIUS CAN BE REDUCED. THE DRAWBAR SHOULD ALSO BE IN THE EXTENDED POSITION.  
  
NOTE: EXCESSIVELY SHARP TURNS WHILE THE MOWER IS RUNNING CAN CAUSE WEAR AND UNDUE STRAIN ON THE MAIN DRIVE-SHAFT. PREMATURE BEARING LOSS CAN OCCUR FROM CONTINUED EXCESSIVELY TIGHT TURNS.
9. DO NOT RIDE THE CLUTCH ON THE TRACTOR. MOW IN THE APPROPRIATE GEARS TO GIVE THE CORRECT GROUND SPEED.

#### OFFSETTING INSTRUCTIONS

1. TO OFFSET BRACES REMOVE BOLTS AND NUTS (ITEM 9 AND 13, PAGE 28) FROM BRACES. RIGHT HAND BRACE WILL MOVE FORWARD, LEFT HAND BRACE WILL MOVE BACK.  
  
NOTE: FOR EVERY HOLE BRACES ARE MOVED MOWER WILL OFFSET 4".
2. TO OFFSET "A" FRAME REMOVE BOLTS, WASHERS AND NUTS (ITEMS 4, 5 AND 6, PAGE 14).
3. REPLACE AND TIGHTEN ALL NUTS AND BOLTS.

## PRE-OPERATION CHECKS

AFTER INSTALLATION OF THE WHEELS AND THE MAIN DRIVESHAFT, THE FOLLOWING PROCEDURES SHOULD BE FOLLOWED BEFORE OPERATING THE MOWER:

1. CHECK THE LEVEL OF THE GEAR GREASE AND LUBRICATION OF ALL LUBE POINTS.
2. HAND ROTATE THE MAIN DRIVESHAFT TO CHECK FREEDOM OF ACTION.
3. CHECK BLADES TO MAKE SURE THEY SWING FREELY.
4. RAISE THE MOWER SLOWLY (LIFT-TYPE MOWERS) AFTER CONNECTING POWER TAKE-OFF TO MAKE SURE THE DRIVESHAFT DOES NOT STRIKE THE FRAME. SHORTEN THE TOP LINK UNTIL THERE IS 1/2" (ONE-HALF INCH) OF CLEARANCE BETWEEN THE DRIVESHAFT AND THE FRAME WHEN THE MOWER IS FULLY RAISED.

## LUBRICATION

1. GEARBOX LUBRICANT SHOULD BE KEPT LEVEL WITH SIDE PLUG. CHECK THE LEVEL EVERY EIGHT HOURS OF OPERATION. (USE TERRAIN KING GREASE OR EQUIVALENT).
2. GREASE UNIVERSAL JOINTS EVERY EIGHT HOURS OF OPERATION.
3. GREASE DRIVESHAFT SLIP JOINT EVERY EIGHT HOURS OF OPERATION. IF THE SLIP JOINT DOES NOT HAVE A GREASE FITTING, SLIP THE SHAFT APART AND PACK THE GREASE EVERY 40 HOURS OF OPERATION.
4. GREASE WHEELS ON THREE-POINT LIFT EVERY EIGHT HOURS OF OPERATION.

## MAINTENANCE

THE TERRAIN KING TK-101 IS DESIGNED FOR RUGGED USE, BUT LIKE ALL MACHINERY IT MUST BE PROPERLY MAINTAINED. PROPER MAINTENANCE WILL ADD HOURS OF USAGE TO THIS MACHINE AND WILL PREVENT COSTLY BREAKDOWNS.



## SLIP CLUTCHES

AFTER THE FIRST HOURS OF OPERATION THE SLIP CLUTCH SHOULD BE CHECKED FOR EXCESSIVE SLIPPAGE, INDICATED BY THE CLUTCH RUNNING HOT. TO PROPERLY ADJUST THE SLIP CLUTCH, SPRING BOLTS SHOULD BE TIGHTENED TO THE LENGTH ILLUSTRATED BELOW. ANY INCREASE OR DECREASE IN TIGHTNESS WILL LOWER THE TORQUE RATING AND COULD CAUSE PREMATURE FAILURE.

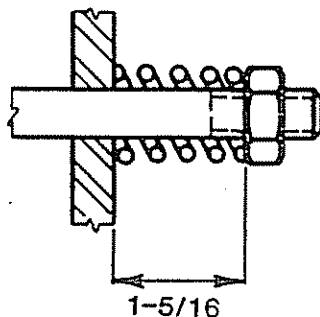

THE SLIP CLUTCH SHOULD BE ADJUSTED AS DESCRIBED PERIODICALLY TO COMPENSATE FOR WEAR. IF THE MOWER HAS BEEN IDLE FOR AN EXTENDED PERIOD OF TIME, THE CLUTCH SHOULD BE CHECKED TO MAKE SURE THE PLATES ARE NOT FROZEN. THE CLUTCH SHOULD BE CHECKED PERIODICALLY FOR WEAR AND THE PRESENCE OF OIL, GREASE, MOISTURE, OR CORROSION ON THE DRIVING PLATES WHICH WILL GREATLY AFFECT THE EFFICIENCY AND LIFE OF THE CLUTCH DISC.

## CUTTING SYSTEM

THE TERRAIN KING 101 IS EQUIPPED WITH REVERSIBLE FORGED STEEL BLADES. THEY SHOULD BE KEPT SHARP AT ALL TIMES TO GIVE THE BEST CUTTING PERFORMANCE AND TO REDUCE THE POWER REQUIREMENTS.

CHECK THE BLADES FOR FREE-SWINGING ACTION AFTER THE MACHINE HAS SET IDLE FOR A PROLONGED PERIOD. IT MAY BE NECESSARY TO APPLY PENETRATING OIL TO LOOSEN THEM. THESE PIVOT POINTS MUST BE KEPT FREE.

WHEN CHANGING BLADES OR REVERSING THE BLADES, REMOVE ALL NICKS AND DIRT FROM THE BLADES AND BLADE HOLDER. AFTER TIGHTENING THE BLADE SWIVEL BOLT, CHECK FOR FREE SWINGING ACTION OF THE BLADE.

## DISASSEMBLY OF SIDE GEARBOX

1. REMOVE BLADE HUB.
2. LOOSEN YOKE RETAINING BOLT AND SLIDE DRIVESHAFT CLEAR OF THE SIDE GEARBOX SHAFT.
3. LOOSEN BOLTS HOLDING GEARBOX ON FRAME AND LIFT OUT GEARBOX.
4. REMOVE TOP COVER AND DRAIN OUT OLD GREASE.
5. FLUSH OUT GEAR HOUSING WITH SOLVENT.
6. REMOVE BEARING CAPS FROM GEAR HOUSING.
7. REMOVE SET SCREW FROM GEAR ON INPUT SHAFT. PRESS FRONT BEARING CONE AND CUP OUT THROUGH FRONT OF GEAR HOUSING. REMOVE REAR BEARING CONE AND GEAR FROM SHAFT.
8. LOOSEN NUT LOCK ON VERTICAL SHAFT AND REMOVE LOCKNUT, NUT LOCK, GEAR, KEY, BEARING SHIELD, AND SPACER FROM SHAFT. PRESS SHAFT OUT OF TOP BEARING CONE. REMOVE LOWER BEARING, GREASE SEAL AND GREASE SEAL RACE FROM SHAFT.
9. CLEAN ALL PARTS WITH SOLVENT, INSPECT FOR WORN OR DAMAGED PARTS, AND REPLACE WITH NEW PARTS IF NECESSARY.

## ASSEMBLY OF SIDE GEARBOX

1. REPLACE LOWER BEARING CONE AND GREASE SEAL. START GREASE SEAL SQUARELY WITH LIP OF SEAL POINTING IN. PRESS SEAL INTO BOX UNTIL IT SEATS AGAINST HOUSING.
2. PRESS GREASE SEAL RACE ON VERTICAL OUTPUT SHAFT. PRESS SHAFT INTO LOWER BEARING CONE. REPLACE TOP BEARING CONE, SPACER, BEARING SHIELD, KEY, GEAR, NUT LOCK AND LOCKNUT. TIGHTEN LOCKNUT UNTIL BEARINGS DRAG WHEN ROTATED. LOOSEN LOCKNUT SLIGHTLY. TAP TOP OF SHAFT. SHAFT SHOULD TURN FREELY WITH NO END PLAY. STAKE NUT TO SHAFT WITH CENTER PUNCH AND SECURE LOCKNUT WITH LOCK EARS. PUT A FEW DROPS OF LOCKTITE ON THE GEAR SET SCREW AND TIGHTEN SECURELY. TURN SHAFT SO THE BLADE HUB KEY IS POINTED TOWARD THE INPUT SHAFT.
3. REPLACE THE GEAR AND HORIZONTAL INPUT SHAFT. PRESS NEW OIL SEAL IN BEARING CAPS WITH LIP POINTING IN. REPLACE THE BEARINGS AND BEARING CAPS. (USE PERMATEx BETWEEN THE CAP AND HOUSING). TAP THE GEAR BACK AGAINST THE SHOULDER AND TIGHTEN THE SET SCREW. (USE LOCKTITE ON THE SET SCREW). CHECK THE GEAR BACKLASH (.006-.016) AND EASE OF ROTATION.
4. FILL THE GEAR HOUSING WITH GREASE TO THE LEVEL OF THE SIDE PLUG AND REPLACE THE TOP COVER. (USE PERMATEx BETWEEN THE COVER AND HOUSING).
5. REPLACE THE GEARBOX ON THE FRAME AND REPLACE THE BLADE HUB.

#### DISASSEMBLY OF CENTER GEARBOX

1. REMOVE SIDE DRIVESHAFTS, MAIN DRIVESHAFT, SLIP CLUTCH ASSEMBLY, AND LOOSEN BOLTS HOLDING GEARBOX ON FRAME AND REMOVE GEARBOX.
2. REMOVE TOP COVER AND DRAIN OUT OLD GREASE.
3. FLUSH OUT HOUSING WITH SOLVENT.
4. LOOSEN SET SCREWS HOLDING GEARS ON SHAFT. LOOSEN BOLTS HOLDING BEARING HOUSING AND REMOVE HOUSING AND GEAR.
5. REMOVE SIDE BEARING CAPS.
6. PRESS BEARING CUP AND CONE (ON OPPOSITE SIDE OF GEAR) OUT OF HOUSING AND PRESS THE CROSS SHAFT OUT OF GEAR AND CONE.
7. IF IT IS NECESSARY TO DISASSEMBLE THE FRONT BEARING HOUSING, LOOSEN THE NUT LOCK AND REMOVE THE LOCKNUT. PRESS SHAFT OUT OF GREASE SEAL, SEAL RACE, AND BEARING CONE. REMOVE GREASE SEAL RACE, GREASE SEAL AND BEARING CONE FROM HOUSING.
8. CLEAN ALL PARTS WITH SOLVENT, INSPECT FOR WORN OR DAMAGED PARTS AND REPLACE WITH NEW PARTS IF NECESSARY.

#### ASSEMBLY OF CENTER GEARBOX

1. REPLACE CROSS SHAFT, KEY, GEAR AND BEARINGS IN HOUSING. PRESS NEW SEALS IN BEARING CAPS WITH LIP POINTED IN AND REPLACE THE BEARING CAPS. (USE PERMATEx BETWEEN CAP AND HOUSING).
2. REASSEMBLE THE FRONT BEARING HOUSING. REPLACE INNER CONE, SHAFT, OUTER CONE, GREASE SEAL RACE, GREASE SEAL (LIP POINTED IN), NUT LOCK AND LOCKNUT. TIGHTEN LOCKNUT TO REMOVE ALL END PLAY AND THEN LOCK WITH NUTLOCK.
3. REPLACE GEAR KEY IN SHAFT. PERMATEx THE FLANGE OF THE BEARING HOUSING, AND HOLD GEAR ON THE INSIDE OF THE GEAR HOUSING. PLACE THE SHAFT IN THE GEAR. TIGHTEN THE BEARING HOUSING ON THE GEAR HOUSING. TAP THE GEARS BACK AGAINST THE SHAFT SHOULDER AND TIGHTEN SET SCREWS IN BOTH GEARS. (USE LOCKTITE ON THE SET SCREWS). CHECK THE GEAR BACKLASH (.006-.016) AND FOR EASE OF ROTATION.
4. FILL THE GEAR HOUSING WITH GREASE TO THE LEVEL OF THE SIDE PLUG AND REPLACE THE SIDE COVER. (USE PERMATEx BETWEEN THE COVER AND HOUSING).
5. REPLACE THE GEARBOX ON THE FRAME AND REPLACE THE BLADE HUB.

# INSTRUCTIONS FOR ORDERING PARTS

THE FOLLOWING INSTRUCTIONS ARE OFFERED TO HELP ELIMINATE NEEDLESS DELAY AND ERROR IN PROCESSING PURCHASE ORDERS FOR TK-101 PARTS.

1. THE PARTS LISTING IS PREPARED IN LOGICAL SEQUENCE, BY PART NUMBER, WITHIN EACH SECTION AND INCLUDES THE DESCRIPTION AND QUANTITY PER UNIT.
2. THE PURCHASE ORDER MUST INDICATE THE NAME AND ADDRESS OF THE PERSON OR ORGANIZATION ORDERING THE PARTS, TO WHOM THE CHARGES ARE TO BE MADE, AND IF POSSIBLE THE SERIAL NUMBER FOR WHICH PARTS ARE BEING ORDERED.
3. THE PURCHASE ORDER MUST CLEARLY LIST THE QUANTITY OF EACH PART, THE COMPLETE AND CORRECT PART NUMBER AND THE BASIC (ONE WORD) NAME OF THE PART ONLY.
4. TERRAIN KING CORPORATION RESERVES THE RIGHT TO SUBSTITUTE PARTS WHERE APPLICABLE.
5. REQUEST QUOTATION FOR UNLISTED ITEMS WHICH ARE SPECIAL PRODUCTION ITEMS NOT NORMALLY STOCKED AND ARE SUBJECT TO SPECIAL HANDLING.
6. TERRAIN KING CORPORATION RESERVES THE RIGHT TO CHANGE PRICES WITHOUT PRIOR NOTICE.

## LIFT MODEL

### TK-101 ASSEMBLY INSTRUCTIONS

YOUR TK-101 LIFT MODEL HAS BEEN PACKAGED FOR SHIPMENT IN CONFORMANCE WITH ICC REGULATIONS TO PROVIDE THE LOWEST POSSIBLE TRANSPORTATION COST AND THE ABSOLUTE MINIMUM ASSEMBLY NECESSARY BEFORE USE. FOR QUICK AND EASY ASSEMBLY, USE THE FOLLOWING STEP BY STEP INSTRUCTIONS.

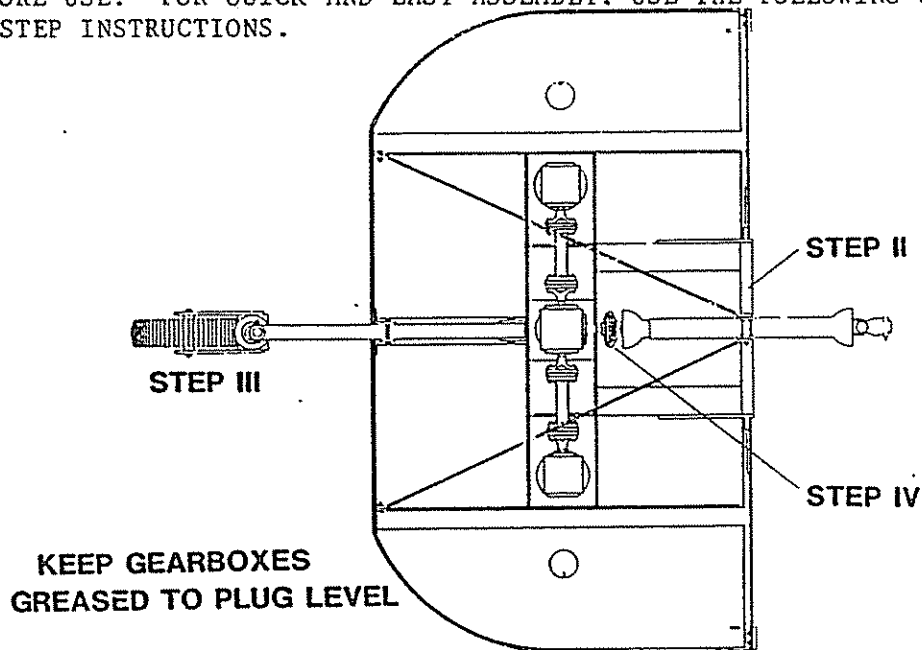

- STEP I: READ ENTIRE ASSEMBLY INSTRUCTIONS AND BECOME FAMILIAR WITH ALL PARTS OF THIS MACHINE. REMOVE ALL WIRE AND BINDING MATERIAL AND ARRANGE ALL LOOSE PARTS IN AN ORDERLY.
- STEP II: ASSEMBLY "A" FRAME.
- ATTACH BOLT LEFT AND RIGHT HAND YOKE BARS (ITEMS 1 & 2, PAGE 28) TO BASE FRAME WITH HITCH PIN AND STOPNUT (ITEMS 5 & 6, PAGE 28). ALSO BOLT AND LOCKNUT (ITEMS 11 & 12, PAGE 28).
  - ATTACH SLOTTED LINKS (ITEM 7, PAGE 28) TO YOKE BARS WITH BOLTS AND LOCKNUTS (ITEMS 8 & 9, PAGE 28). ROUND HOLES IN LINKS SHOULD BE TO FRONT OF MOWER AND SLOTS TO THE REAR. CENTER BUSHING (ITEM 4, PAGE 28) AS SHOWN.
  - ATTACH A-FRAME BRACE SUPPORTS (ITEM 3, PAGE 28) TO YOKE BARS WITH BOLTS AND LOCKNUTS (ITEMS 24 & 25, PAGE 28).
- STEP III: ASSEMBLE TAIL WHEEL ASSEMBLY
- ATTACH CASTER FORK AND WHEEL TO TAIL WHEEL TUBE WELDMENT AS SHOWN ON (PAGE 29).
  - ATTACH TAIL ASSEMBLY TO BASE FRAME WITH BOLTS, LOCK-WASHERS, AND NUTS (ITEMS 2, 3 AND 4, PAGE 29).
- STEP IV: ATTACH DRIVESHAFT TO GEARBOX WITH BOLT KIT, (ITEM 5, PAGE 23).

## PULL MODEL

### ASSEMBLY INSTRUCTIONS

YOUR TK-101 PULL MODEL HAS BEEN PACKAGED FOR SHIPMENT IN CONFORMANCE WITH ICC REGULATIONS TO PROVIDE THE LOWEST POSSIBLE TRANSPORTATION COST AND THE ABSOLUTE MINIMUM ASSEMBLY NECESSARY BEFORE USE. FOR QUICK AND EASY ASSEMBLY USE THE FOLLOWING STEP BY STEP INSTRUCTIONS.

STEP I: READ ENTIRE ASSEMBLY INSTRUCTIONS AND BECOME FAMILIAR WITH ALL PARTS OF THIS MACHINE. REMOVE ALL WIRE AND BINDING MATERIAL AND ARRANGE ALL LOOSE PARTS IN AN ORDERLY MANNER.

STEP II: ATTACH TONGUE ASSEMBLY TO BASE FRAME WITH BOLTS AND NUTS (ITEMS 4 & 5, PAGE 30).

STEP III: ATTACH RATCHET JACK OR HYDRAULIC CYLINDER TO AXLE AND ADJUST TO DESIRED CUTTING HEIGHT.

NOTE: IF HYDRAULIC CYLINDER IS USED, THE SCREW ADJUSTMENT YOKE ON THE ROD END CAN BE SCREWED OUT TO A MAXIMUM OF 2 1/4". CUTTING HEIGHT CAN BE FROM 1" TO 18" DEPENDING ON TIRE SIZE AND CYLINDER SETTING. THE CHART SHOWS HOW THIS IS ACCOMPLISHED.

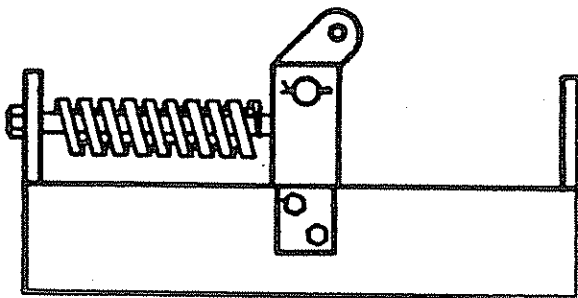

**A**

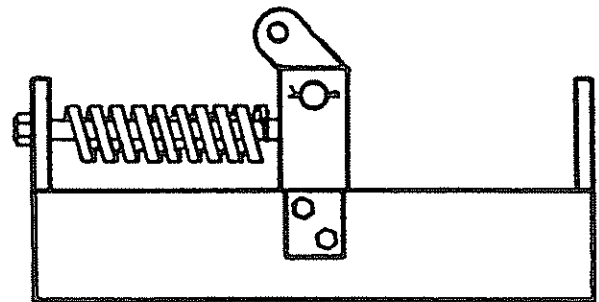

**B**

CYLINDER SETTING	20" DIAMETER TIRE		IMPLEMENT TIRE (6:70 X 15)	
	FIG.A	FIG.B	FIG.A	FIG.B
CYLINDER RETRACTED & ADJUSTMENT SCREWED IN	2"	0"	5"	0"
CYLINDER EXTENDED & ADJUSTMENT SCREWED IN	14"	6"	9"	8"
CYLINDER RETRACTED & ADJUSTMENT SCREWED OUT	8"	0"	12"	3"
CYLINDER EXTENDED & ADJUSTMENT SCREWED OUT	14"	13"	17"	13"

BASE ASSEMBLY  
P/N 00754678

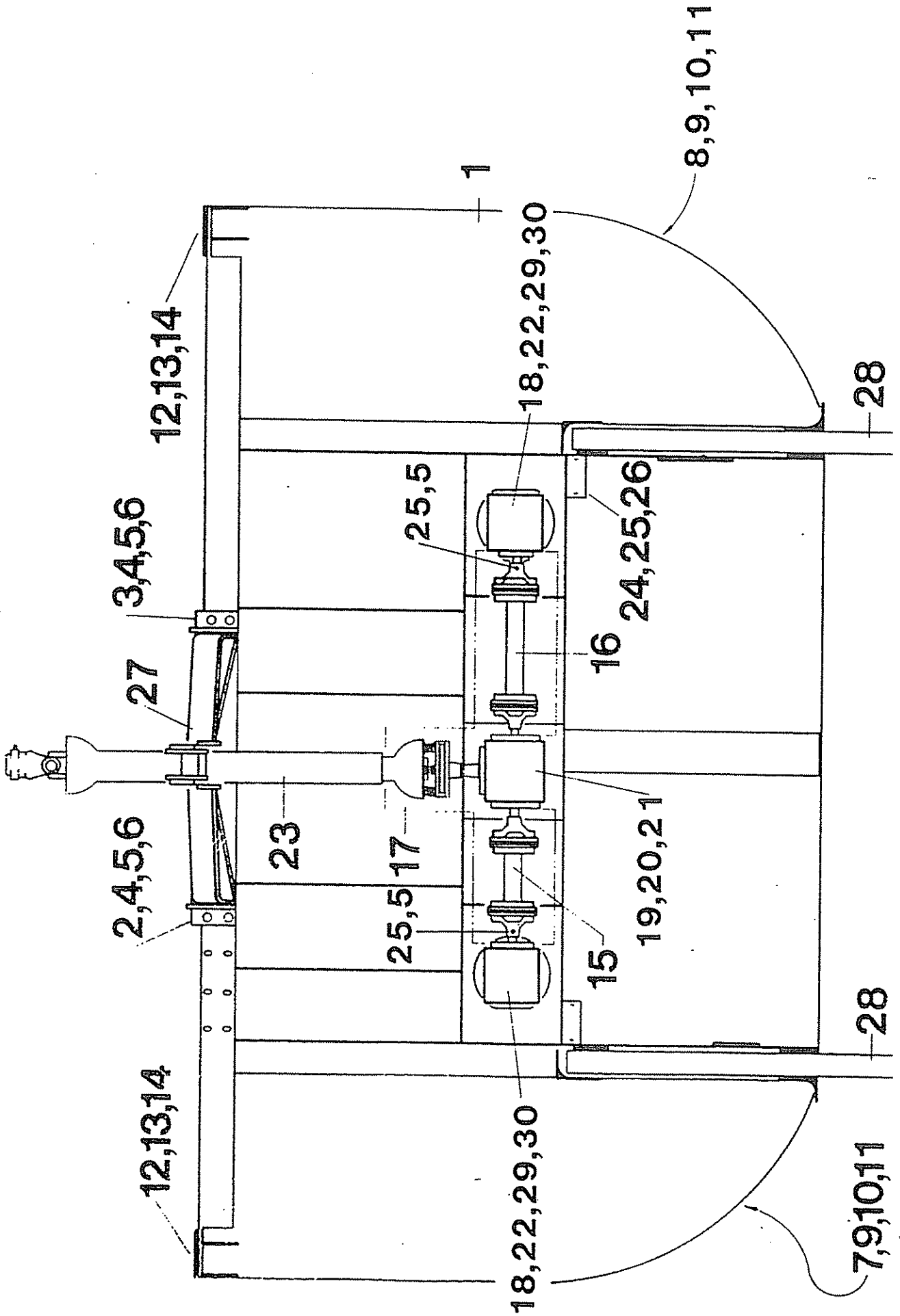

# LIFT MODEL BASE ASSEMBLY

## P/N 00754678

ITEM	PART NO.	DESCRIPTION	QTY
1	00754679	FRAME WELDMENT	1
2	00753551	LEFT HAND HITCH PLATE	1
3	00753750	RIGHT HAND HITCH PLATE	1
4	00748823	BOLT	12
5	00749137	NUT	14
6	00002700	FLATWASHER	26
7	00754130	CCW BLADE BAR ASSEMBLY	1
8	00754129	CW BLADE BAR ASSEMBLY	1
9	00606100	NUT	2
10	00606000	COTTER PIN	2
11	00748547	FLATWASHER	2
12	00743179	RIGHT HAND SKID SHOE WELDMENT	1
	00753180	LEFT HAND SKID SHOE WELDMENT	1
13	00002400	BOLT	4
14	00019400	NUT	4
15	00754446	FLEXIBLE COUPLING	1
16	00754306	FLEXIBLE COUPLING	1
17	00753097	SAFETY SHIELD ASSEMBLY	1
18	00754811	SIDE GEARBOX	2
19	02030700	BOLT	4
20	00001300	LOCKWASHER	4
21	00754810	CENTER GEARBOX	1
22	00008300	BOLT	8
23	00754173	DRIVESHAFT	1
24	00747600	INSPECTION COVER PLATE	2
25	00752716	BOLT	2
26	00004000	WINGNUT	2
27	-----	"A" FRAME ASSEMBLY	1
28	-----	TAILWHEEL ASSEMBLY	2
29	00010400	NUT	8
30	00010300	LOCKWASHER	8



**TK-101  
BASE ASSEMBLY - PULL MODEL**

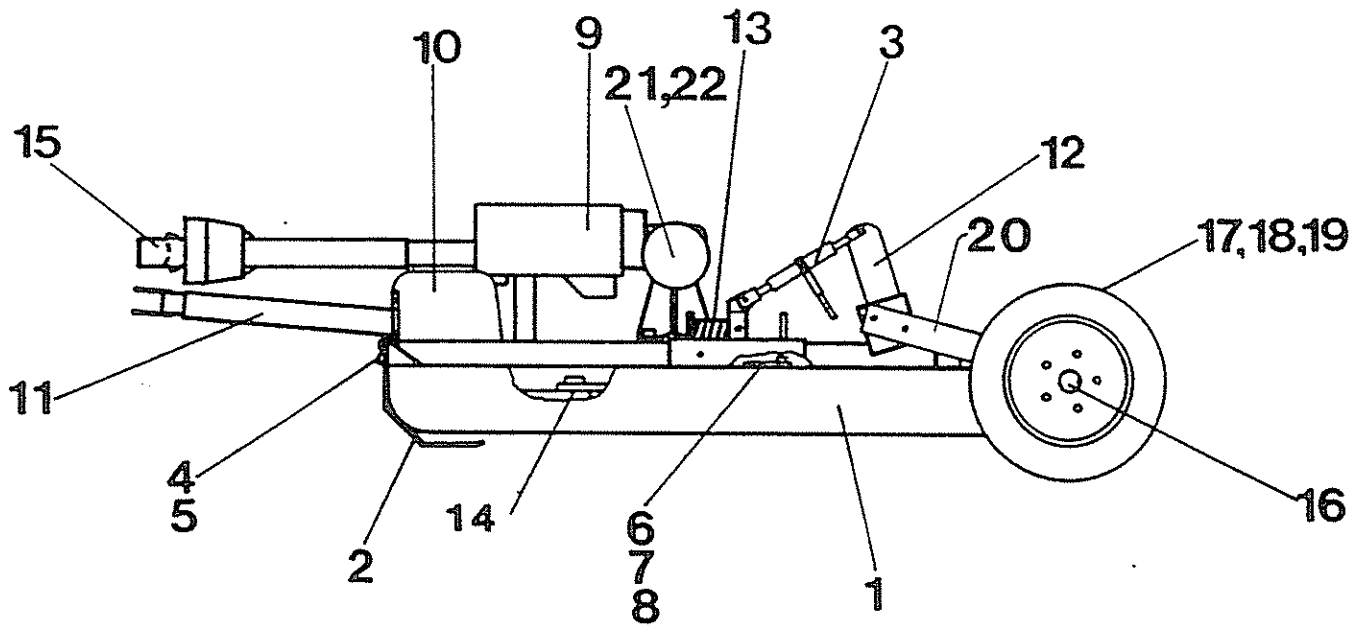

ITEM	PART NO.	DESCRIPTION	QTY
1	00754679	FRAME WELDMENT	1
2	00753179	RIGHT HAND SKID SHOE	1
	00753180	LEFT HAND SKID SHOE	1
3	00554600	RATCHET JACK	1
4	00607900	BOLT	4
5	00019400	NUT	4
6	00747600	COVER PLATE	2
7	00004000	NUT	2
8	00024100	LOCKWASHER	2
9	00753097	SAFETY SHIELD ASSEMBLY	1
10	00753750	PULL HITCH PLATE RIGHT HAND	2
	00753751	PULL HITCH PLATE LEFT HAND	2
11	00754144	TONGUE WELDMENT	1
12	00754479	AXLE ARM ASSEMBLY	1
13	00754231	SHOCK ABSORBER ASSEMBLY	1
14	00754129	BLADE ASSEMBLY (CCW)	1
	00754130	BLADE ASSEMBLY (CLOCKWISE)	1
15	00754174	DRIVESHAFT W/SLIPCLUTCH	1
16	00752753	WHEEL HUB ASSEMBLY	2
17	00025200	TIRE AND WHEEL ASSEMBLY	2
18	00019200	RIM 14" OPTIONAL	2
19	00008700	RIM 15" OPTIONAL	2
20	00753718	AXLE WELDMENT	1
21	00754810	CENTER GEARBOX	1
	02030700	BOLT, CENTER GEARBOX ATTACHMENT	4
	00001300	LOCKWASHER, CTR GRBX ATTACHMENT	4
22	00754811	SIDE GEARBOX	2
	00008300	BOLT, SIDE GEARBOX ATTACHMENT	8
	00010400	NUT, SIDE GEARBOX ATTACHMENT	8
	00010300	LOCKWASHER, SIDE GRBX ATTACHMENT	8

# BLADE BAR ASSEMBLY

CLKWISE P/N 00754129 CNTRCLKWISE P/N 00754130

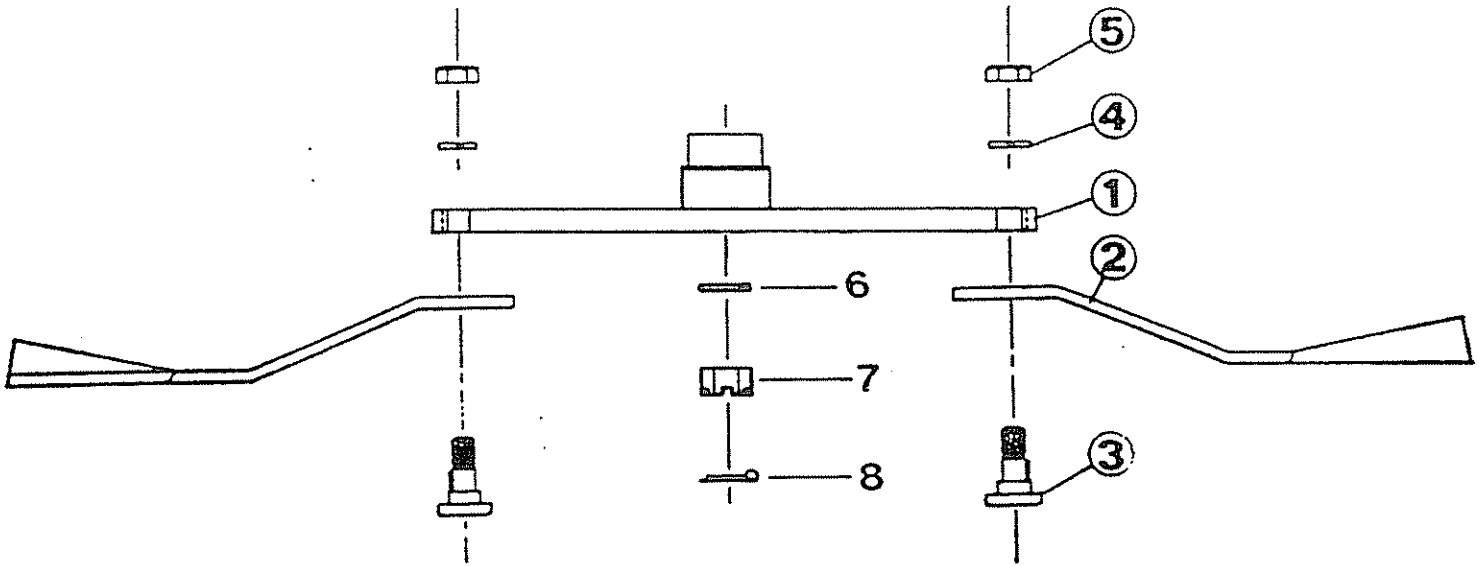

TORQUE ITEMS #3 & #7 TO 250 ft.lbs.

ITEM	PART NO.	DESCRIPTION	QTY
1	00754126	BLADE BAR WELDMENT	1
2	00753842	BLADE COUNTERCLKWISE	1
	00753841	BLADE CLOCKWISE	1
3	00752827	BLADE BOLT	2
4	00748000	LOCKWASHER	2
5	00747900	NUT	2
6	00748547	WASHER	REF
7	00606100	NUT	REF
8	00606000	COTTER PIN	REF

# CENTER GEARBOX P/N 00754810

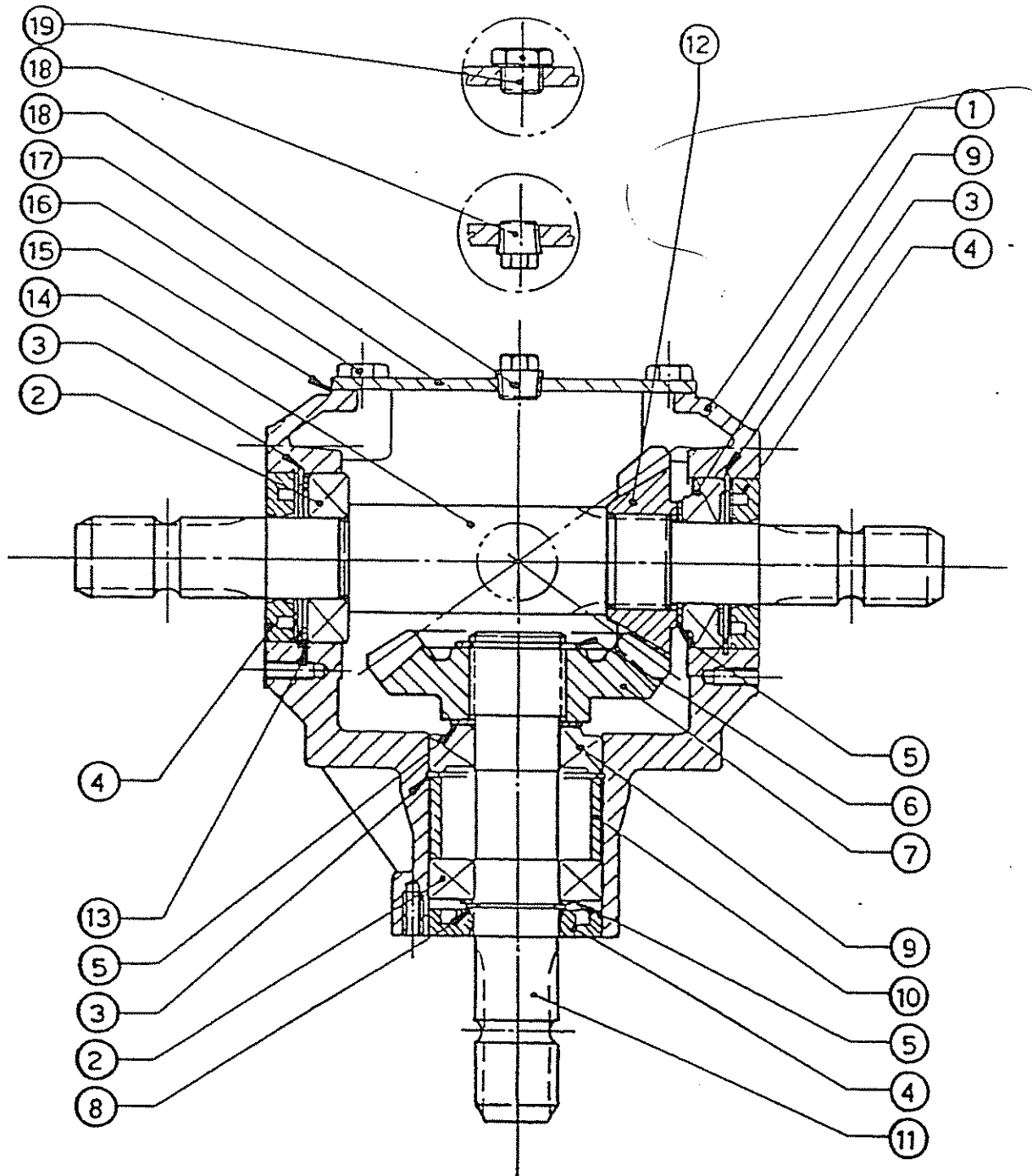

# CENTER GEARBOX

## P/N 00754810

ITEM	PART NO.	DESCRIPTION	QTY
1	00754750	CASING	1
2	00754751	BEARING	2
3	00754752	INTERNAL CLIP	3
4	00754753	DUST EXCLUDER	3
5	00754754	SHIM	3
6	00752927	EXTERNAL CIRCLIP	1
7	00754755	CROWNWHEEL	1
8	00754756	EXTERNAL CIRCLIP	1
9	00754757	BEARING	2
10	00754758	SPACER	1
11	00754759	SHAFT	1
12	00754760	BEVEL PINION	1
13	00754761	SHIM	1
14	00754762	SHAFT	1
15	00754763	GASKET	1
16	00754764	BOLT	4
17	00754765	COVER	1
18	00752931	PLUG	2
19	00754766	OIL FILLER PLUG	1

# SIDE GEARBOX P/N 00754811

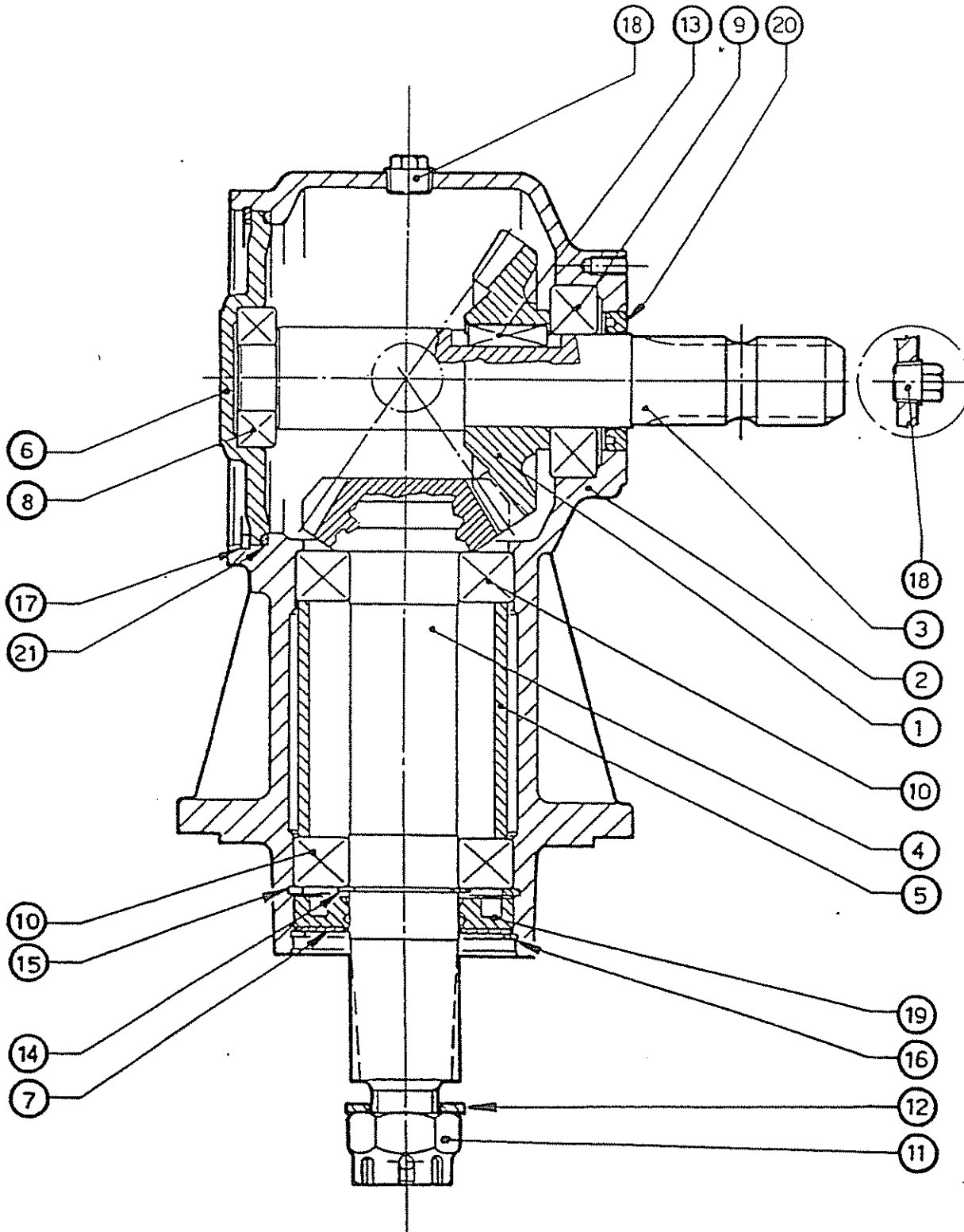

# SIDE GEARBOX

## P/N 00754811

ITEM	PART NO.	DESCRIPTION	QTY
1	00754767	CROWNWHEEL	1
2	00754768	CASING	1
3	00754769	SHAFT	1
4	00754770	PINION SHAFT	1
5	00754771	SPACER	1
6	00754772	COVER	1
7	00754773	PROTECTIVE SHIELD	1
8	00754774	BEARING	1
9	00754775	BEARING	1
10	00754776	BEARING	2
11	00754777	CASTLE NUT	1
12	00754778	BOLT WASHER	1
13	00754779	PARALLEL KEY	1
14	00752927	EXTERNAL CIRCLIP	1
15	00754780	INTERNAL CIRCLIP	1
16	00754781	SHOULDER RING	1
17	00754782	SHOULDER RING	1
18	00752931	PLUG	2
19	00754783	DUST EXCLUDER	1
20	00754784	OIL SEAL	1
21	00754785	O-RING	1

# FLEXIBLE COUPLING P/N 00754306

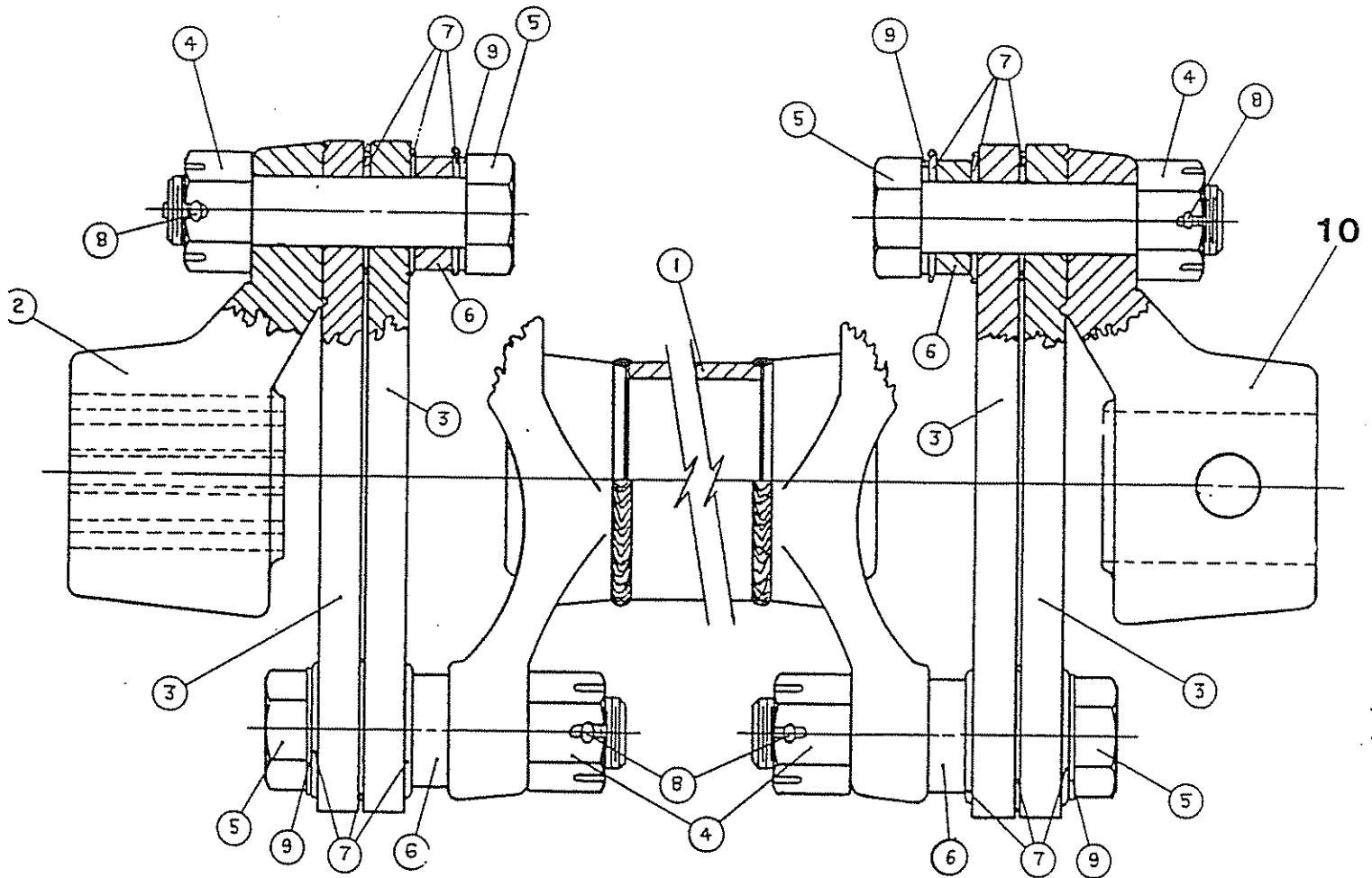

ITEM	PART NO.	DESCRIPTION	QTY
1	00753261	CENTER SPIDER WELDMENT	1
2	00750263	SPIDER FLEX COUPLER	1
3	00749172	RUBBER SPACER	4
4	00748742	NUT	12
5	00749756	BOLT	12
6	00749759	SPACER	12
7	00749760	BEADED WASHER	36
8	00026200	COTTER PIN	12
9	00750996	WASHER	12
10	00750265	SPIDER FLEX COUPLER (SMOOTH)	1

# FLEXIBLE COUPLING

## P/N 00754446

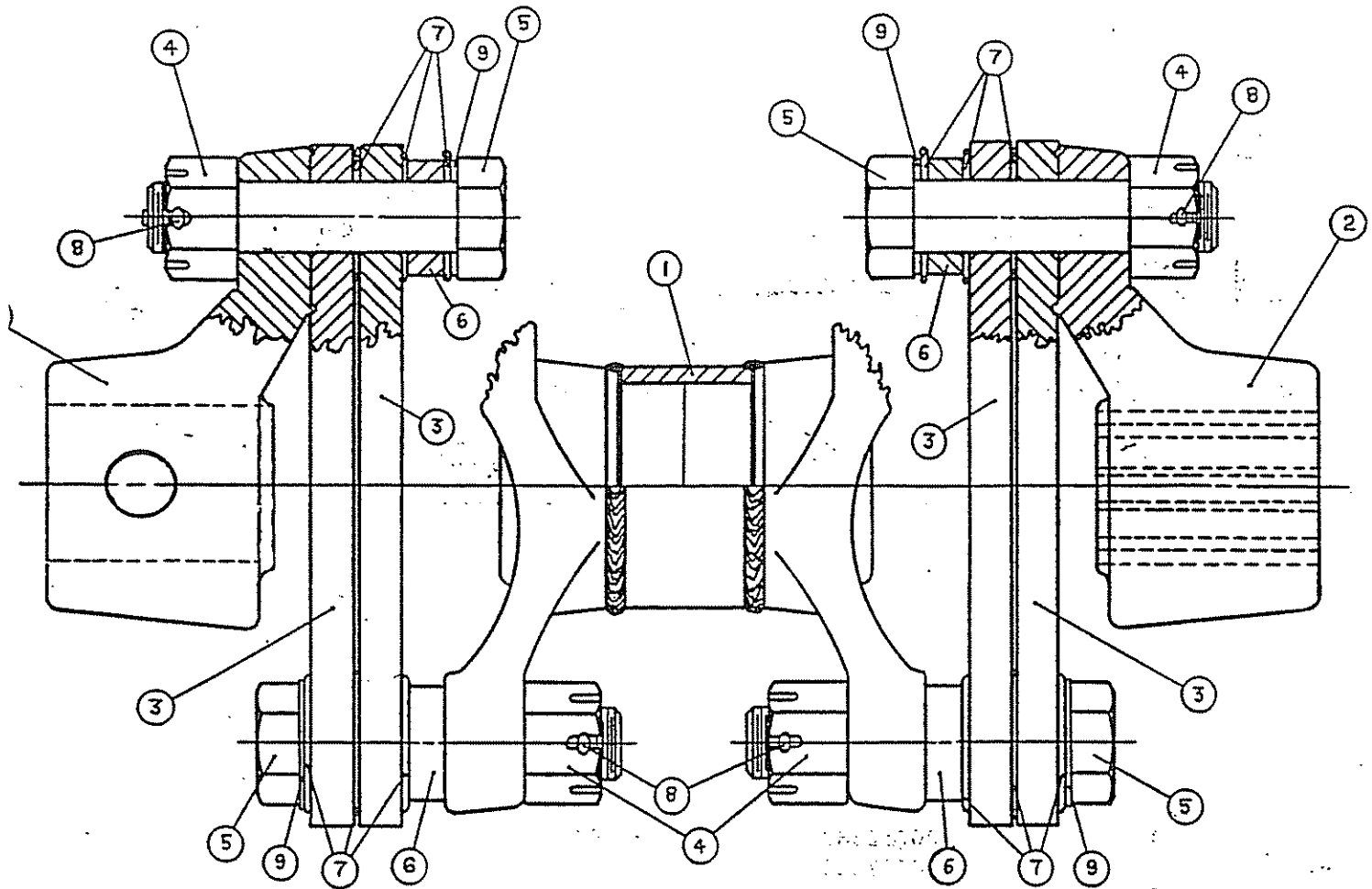

ITEM	PART NO.	DESCRIPTION	QTY
1	00754449	CENTER SPIDER WELDMENT	1
2	00750263	SPIDER FLEX COUPLER	1
3	00749172	RUBBER SPACER	4
4	00748742	NUT	12
5	00749756	BOLT	12
6	00749759	SPACER	12
7	00749760	BEADED WASHER	36
8	00026200	COTTER PIN	12
9	00750996	WASHER	12
10	00750265	SPIDER FLEX COUPLER (SMOOTH)	1



# PULL MODEL DRIVESHAFT P/N 00754174

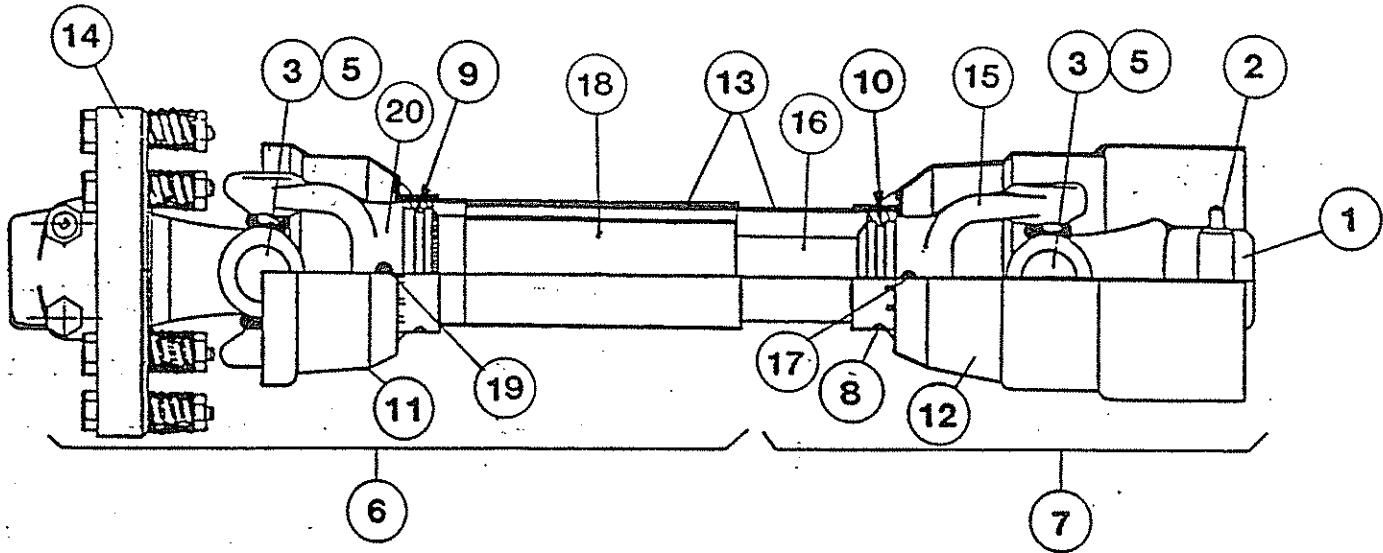

ITEM	PART NO.	DESCRIPTION	QTY
1	00752883	OUTER YOKE	1
2	00752880	PUSH PIN SET	1
3	00752896	CROSS JOURNAL SET	2
4	00754335	GREASE NIPPLE FOR TUBE	1
5	00754334	GREASE NIPPLE FOR CROSS	2
6	00754420	MOWER HALF COMPLETE	1
7	00754421	TRACTOR HALF COMPLETE	1
8	00754330	NYLON BOLT	6
9	00754332	LOCKING COLLAR OUTER	1
10	00754331	LOCKING COLLAR INNER	1
11	00754422	SHIELD COMPLETE OUTER	1
12	00754423	SHIELD COMPLETE INNER	1
13	00754424	SHIELD COMPLETE	1
14	00754320	CLUTCH	1
15	00754153	YOKE - INNER TUBE	1
16	00755516	INNER TUBE	1
17	00754167	ROLL PIN - INNER TUBE	1
18	00755517	OUTER TUBE	1
19	00754166	ROLL PIN - OUTER TUBE	1
20	00754154	YOKE - OUTER TUBE	1

# LIFT MODEL DRIVESHAFT P/N 00754173

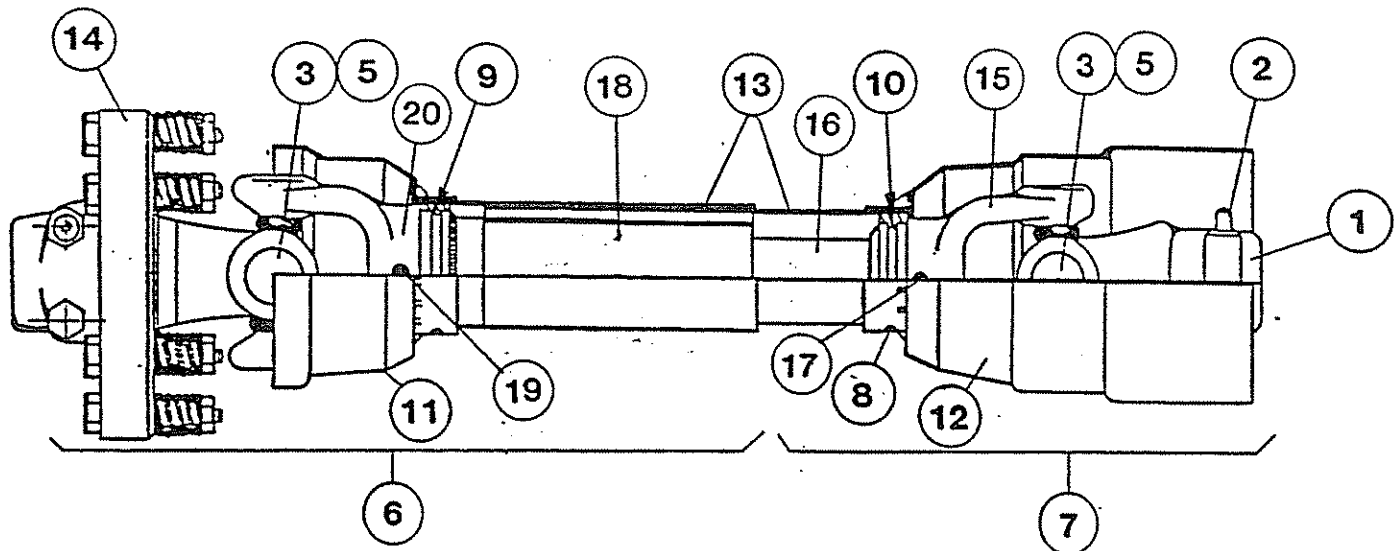

ITEM	PART NO.	DESCRIPTION	QTY
1	00752883	OUTER YOKE	1
2	00752880	PUSH PIN SET	1
3	00752896	CROSS JOURNAL SET	2
4	00754335	GREASE NIPPLE FOR TUBE	1
5	00754334	GREASE NIPPLE FOR CROSS	2
6	00754420	MOWER HALF COMPLETE	1
7	00754421	TRACTOR HALF COMPLETE	1
8	00754330	NYLON BOLT	6
9	00754332	LOCKING COLLAR OUTER	1
10	00754331	LOCKING COLLAR INNER	1
11	00754422	SHIELD COMPLETE OUTER	1
12	00754423	SHIELD COMPLETE INNER	1
13	00754424	SHIELD COMPLETE	1
14	00754320	CLUTCH	1
15	00754153	YOKE - INNER TUBE	1
16	00755514	INNER TUBE	1
17	00754167	ROLL PIN - INNER TUBE	1
18	00755515	YOKE - OUTER TUBE	1
19	00754166	ROLL PIN	1
20	00754154	YOKE - OUTER TUBE	1

# SLIPCLUTCH P/N 00754320

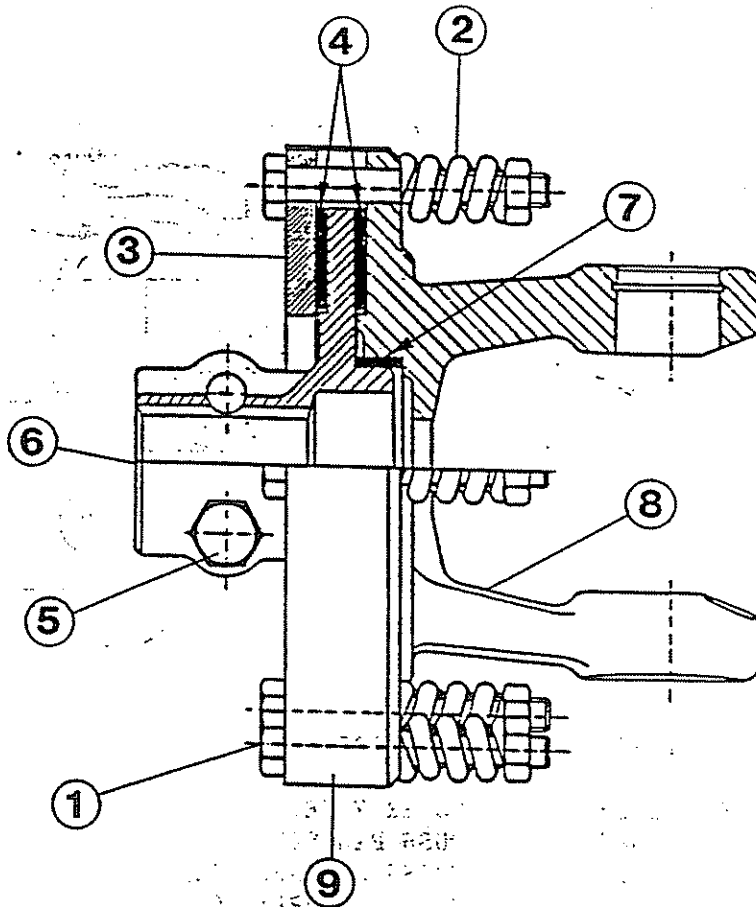

ITEM	PART NO.	DESCRIPTION	QTY
1	00754316	BOLT	8
2	00754315	SPRING	8
3	00754203	OUTER FLANGE	1
4	00754202	DISK	2
5	00752903	BOLT AND NUT	2
6	00754317	BODY - FRICTION CLUTCH	1
7	00754301	SPACER	1
8	00754302	YOKE FRICTION	1
9	00754318	DIRT SHIELD	1

# DRIVESHAFT SAFETY SHIELD ASSEMBLY

P/N 00753097

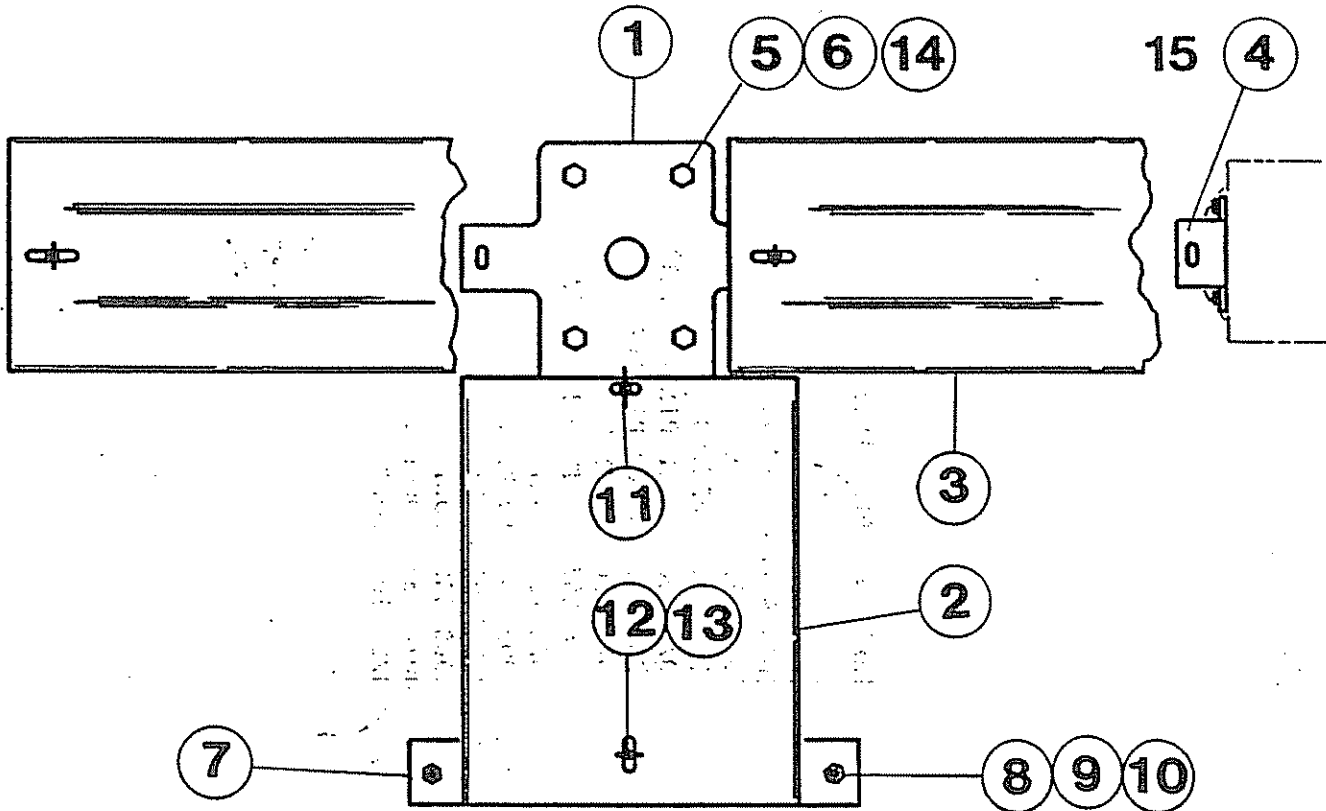

ITEM	PART NO.	DESCRIPTION	QTY
1	00752441	MOUNT PLATE - CENTER	1
2	00752442	SAFETY SHIELD - SLIP CLUTCH	1
3	00752443	SAFETY SHIELD - FLEX COUPLING RH	2
4	00754822	MOUNT PLATE	2
5	00748823	BOLT	4
6	00001400	FLATWASHER	4
7	00752459	STRAP	1
8	00022200	LOCKWASHER	4
9	00019700	FLATWASHER	4
10	00999316	NUT	4
11	00751685	CLIP	1
12	00751588	THUMBSCREW	6
13	00752536	NUT	5
14	00010300	LOCKWASHER	4
15	00751693	BOLT	4

# A-FRAME ASSEMBLY

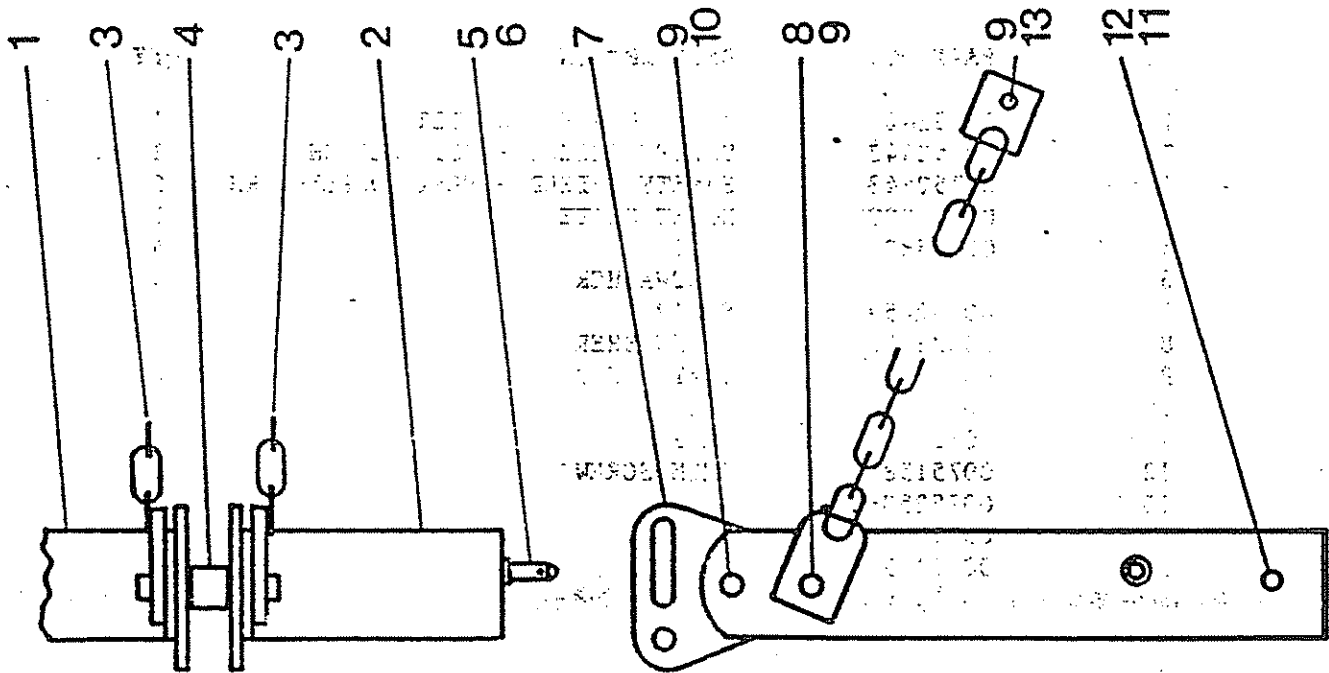

ITEM	PART NO.	DESCRIPTION	QTY
1	00752575	YOKE BAR WELDMENT RIGHT HAND	1
2	00749926	YOKE BAR WELDMENT LEFT HAND	1
3	00753117	BRACE	1
4	00748569	BUSHING	2
5	00748100	HITCH PIN (CAT. II)	2
6	00603500	HITCH PIN (CAT. I)	2
7	00747500	STOPNUT	2
8	00749857	SLOTTED LINK (CAT. II)	2
9	00748786	BOLT	1
10	00037200	LOCKNUT	2
11	00748598	BOLT	1
12	00603300	BOLT	2
13	00749136	LOCKNUT	2
13	02892100	BOLT	2

# TAILWHEEL ASSEMBLY

ITEM	PART NO.	DESCRIPTION	QTY
1	00752475	TUBE, TAIL WHEEL	1
2	02711800	BOLT	3
3	00001300	LOCKWASHER	3
4	02816800	NUT	3
5	00749264	COLLAR	1
6	00749413	BOLT	1
7	00749017	NUT	1
8	00748751	CASTER FORK	1
9	00156503	BOLT	1
10	00752272	AXLE HUB	1
11	02817100	BEARING ASS'Y (CONE & CUP)	2
12	00013600	SEAL	*
13	00130010	TIRE AND WHEEL ASSEMBLY	*
14	00695100	NUT	1

\* PART OF 00130010 - TIRE AND WHEEL ASSEMBLY

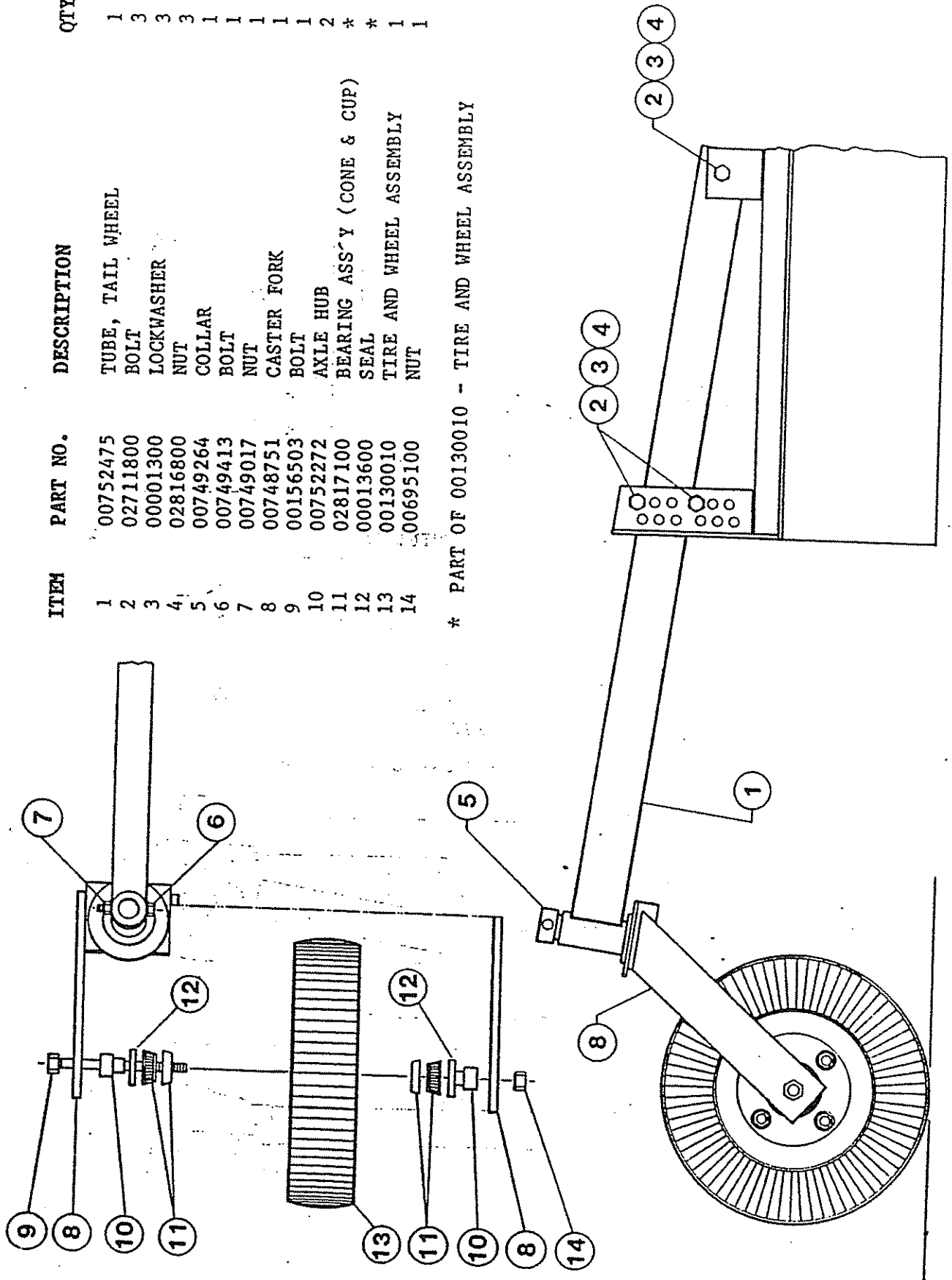

# TONGUE ASSEMBLY

## P/N 00754144

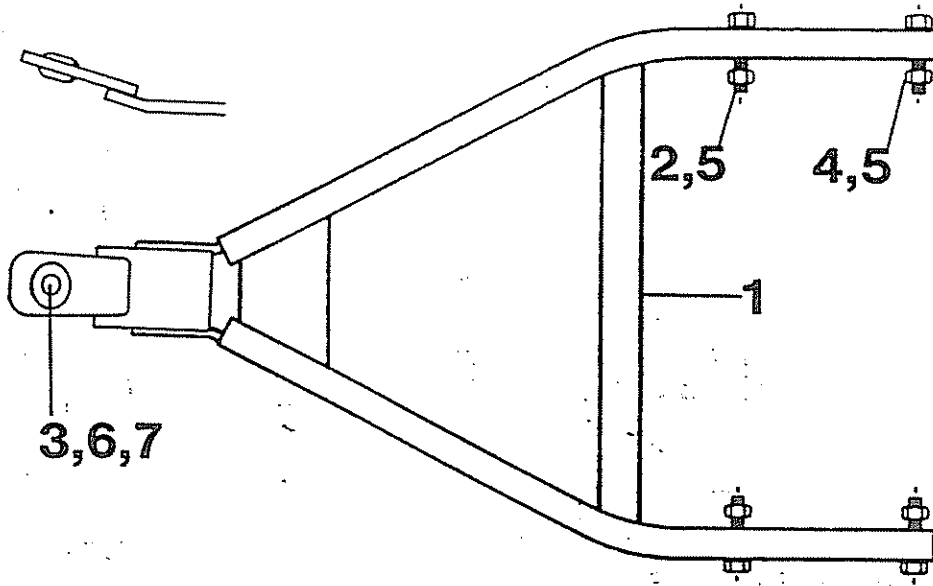

ITEM	PART NO.	DESCRIPTION	QTY
1	00753748	TONGUE WELDMENT	1
2	00750952	BOLT	2
3	00750477	BOLT	1
4	02845600	BOLT	2
5	00695100	NUT	4
6	00749946	WASHER	1
7	02030300	NUT	1

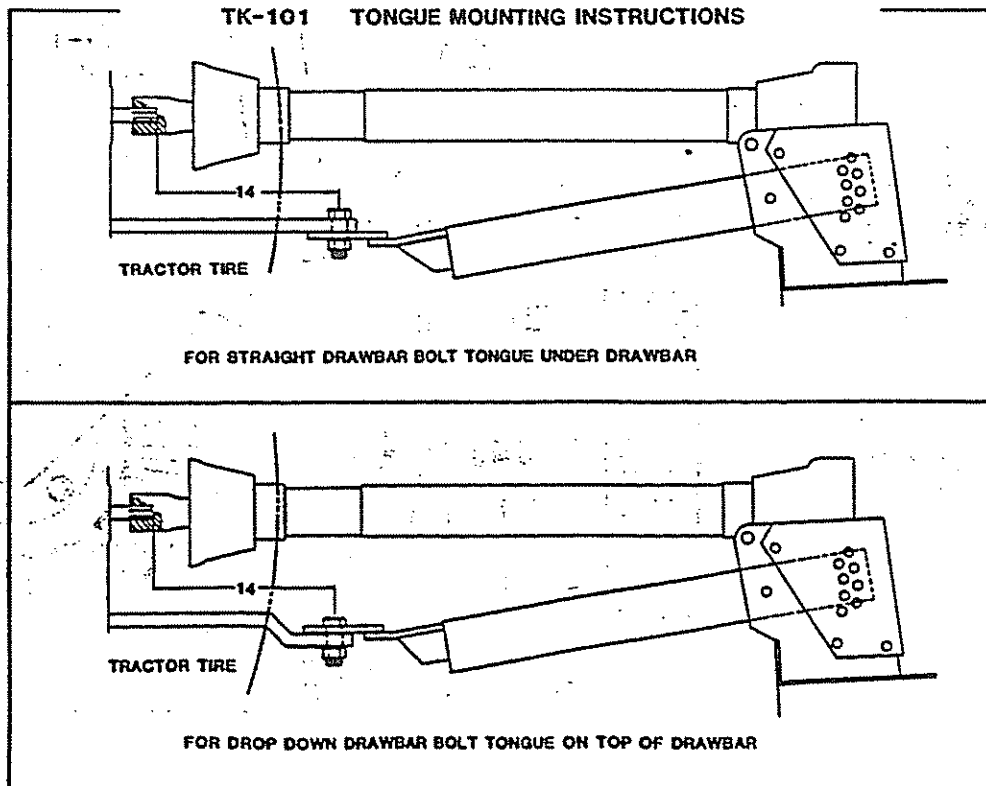

# SHOCK ABSORBER ASSEMBLY P/N 00754231

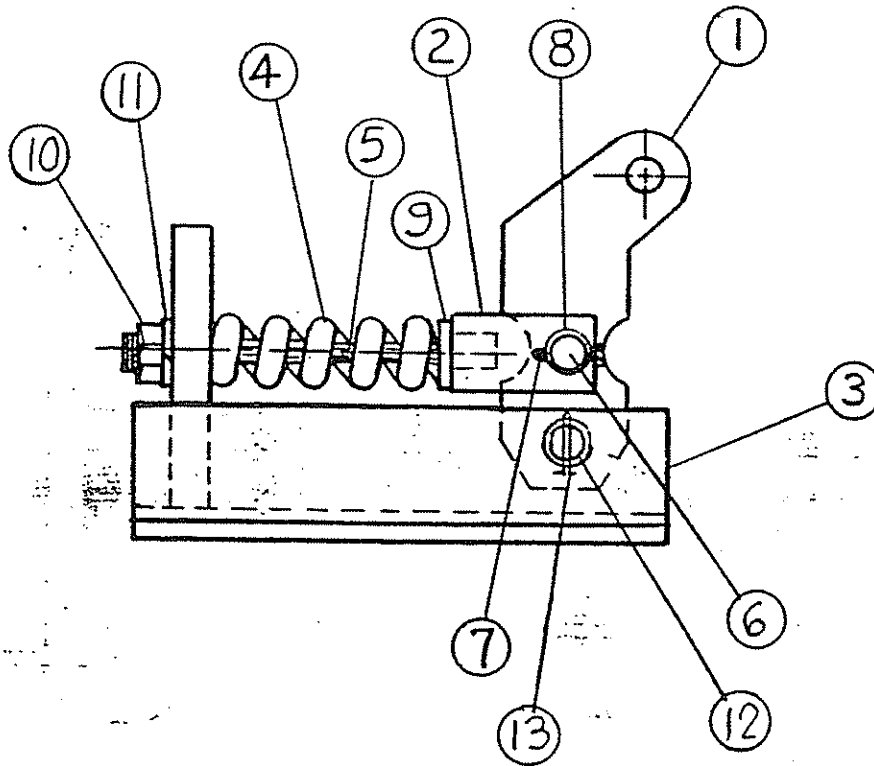

## SHOCK ABSORBER ASSEMBLY P/N 00754231

ITEM	PART NO.	DESCRIPTION	QTY
1	00754221	SHOCK ABSORBER CYL.LUG WLDMT.	1
2	00754224	SHOCK ABSORBER ROD WLDMT.	1
3	00754229	SHOCK ABSORBER WLDMT.	1
4	00750739	SPRING	1
5	00749168	SPACER TUBE	1
6	00748813	CENTER PIN	1
7	00000400	COTTER PIN	2
8	02822500	FLATWASHER	2
9	00749946	FLATWASHER	1
10	00059500	NUT	1
11	02032200	LOCKWASHER	1
12	00754230	PIN	1
13	00752667	ROLL PIN	1



# AXLE ASSEMBLY

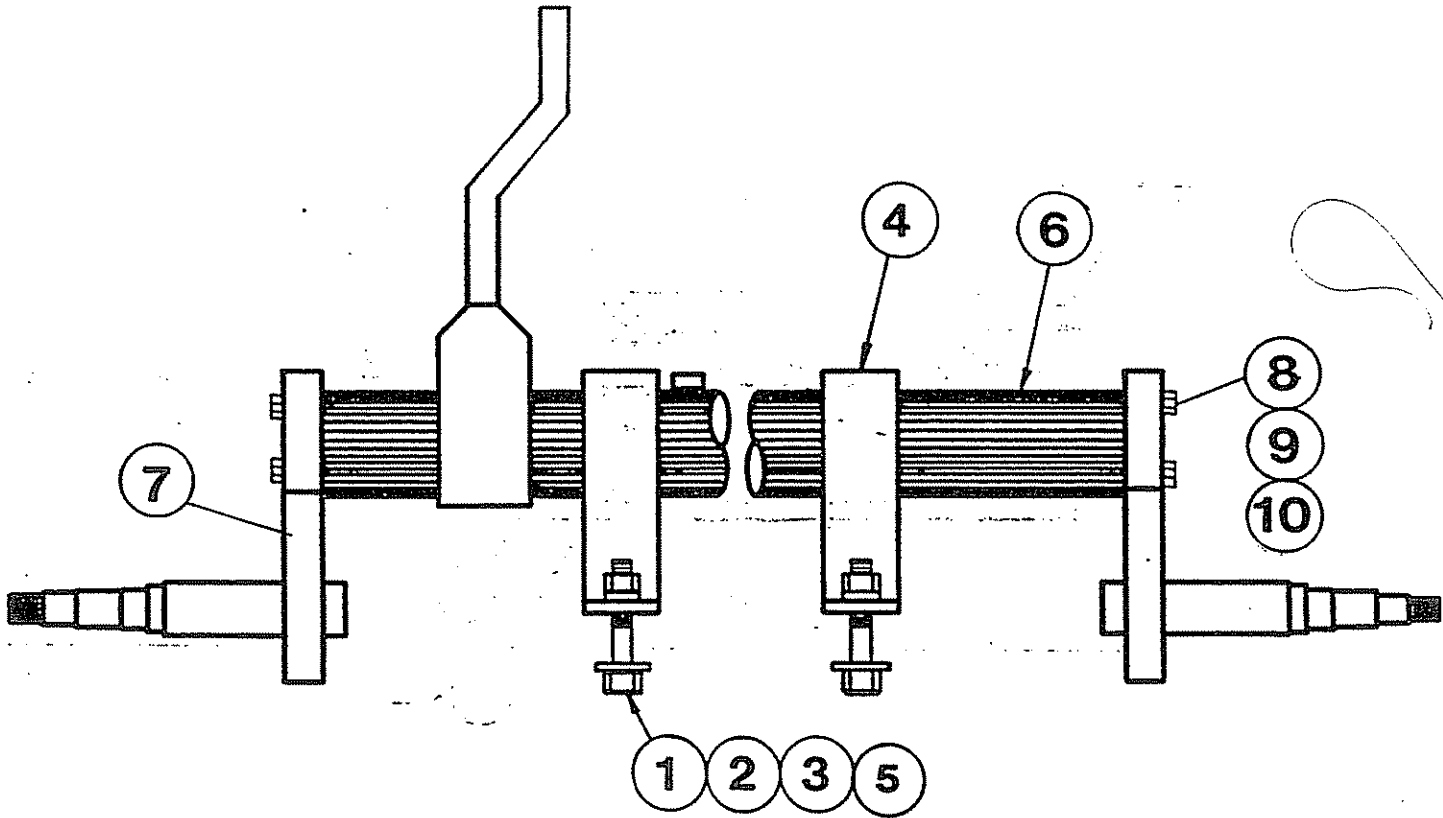

ITEM	PART NO.	DESCRIPTION	QTY
1	00748823	BOLT	4
2	00001300	LOCKWASHER	4
3	00001200	NUT	4
4	00754657	CLAMP WELDMENT	1
5	00002700	FLATWASHER	8
6	00753718	AXLE WELDMENT	1
7	00754477	AXLE ARM WELDMENT	2
8	00703200	BOLT	4
9	00010300	LOCKWASHER	4
10	00010400	NUT	4

# WHEEL HUB ASSEMBLY P/N 00752753

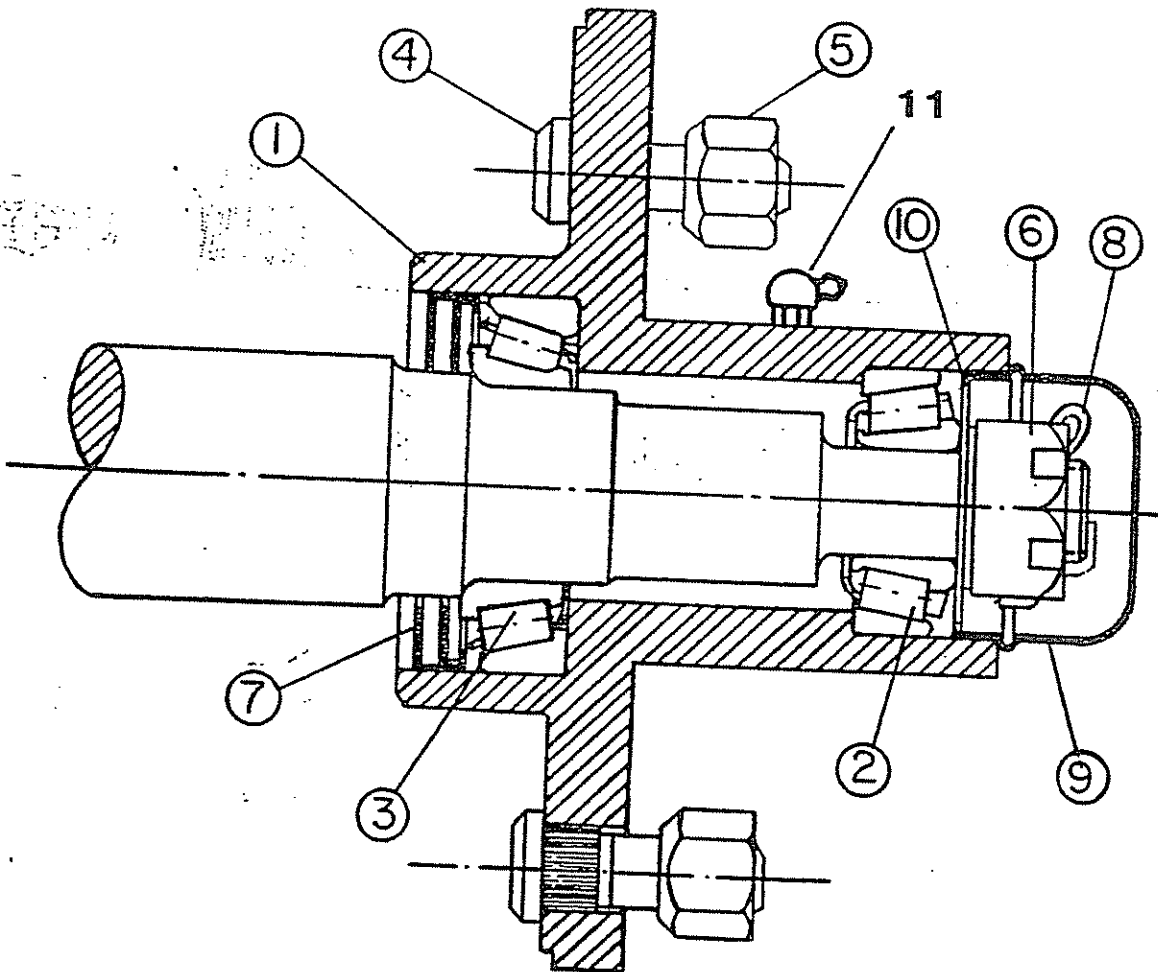

ITEM	PART NO.	DESCRIPTION	QTY
1	00752752	WHEEL HUB W/CUPS, STUDS NUTS, AND ZERK FITTINGS	1
2	00753721	BEARING CONE AND CUP	1
3	00753720	BEARING CONE AND CUP	1
4	00752177	STUD BOLT	1
5	00750614	NUT	5
6	00750615	NUT	5
7	00750616	SEAL	1
8	00000400	COTTER PIN	1
9	00752751	DUST CAP	1
10	00750618	WASHER	1
11	00752176	ZERK FITTINGS	1
12	00752753	WHEEL HUB ASSEMBLY INCLUDES ITEMS 1-11	1

# RATCHET JACK ASSEMBLY

## P/N. 00554600

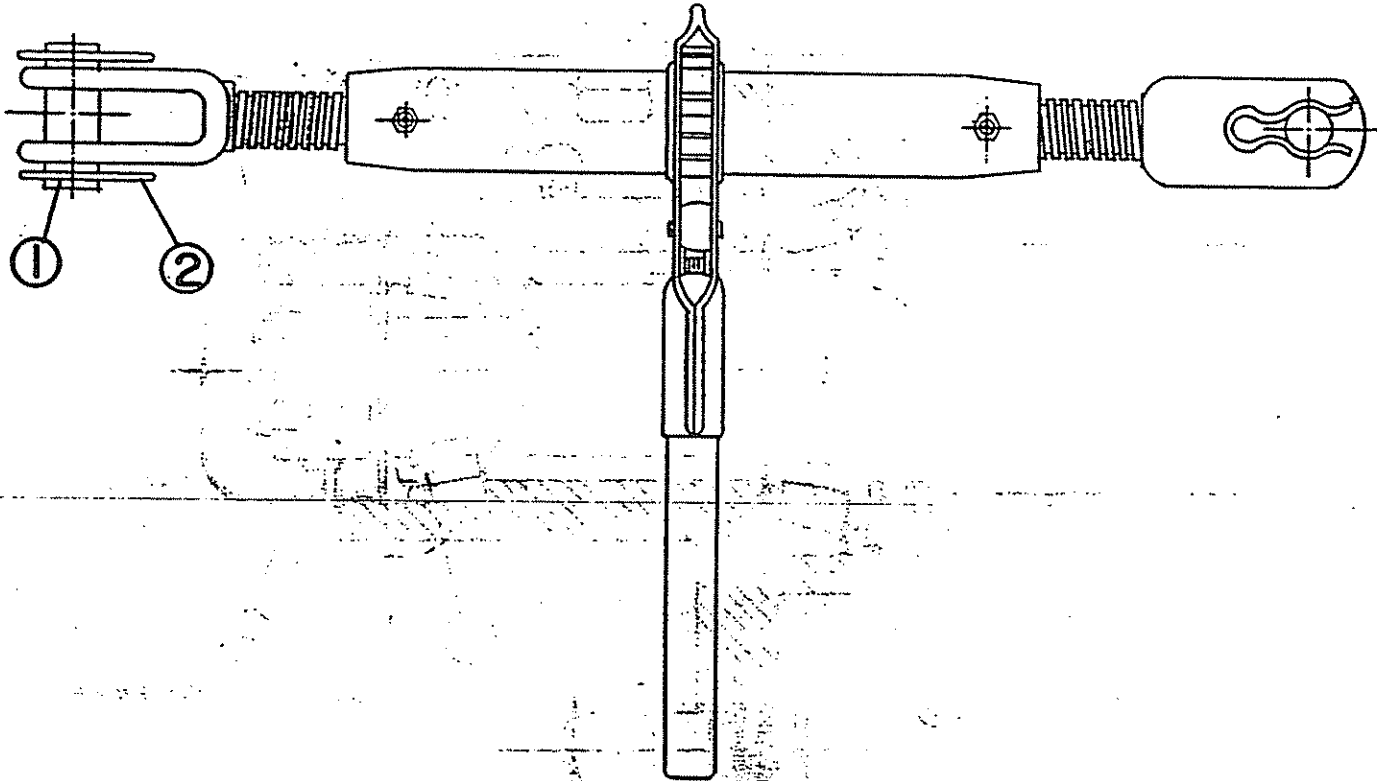

ITEM	PART NO.	DESCRIPTION	QTY
1	00748714	PIN	2
2	00748715	CLIP	4

# STUMP JUMPER PAN ASSEMBLIES

CLKWISE 00754499 CNTRCLKWISE 00754498

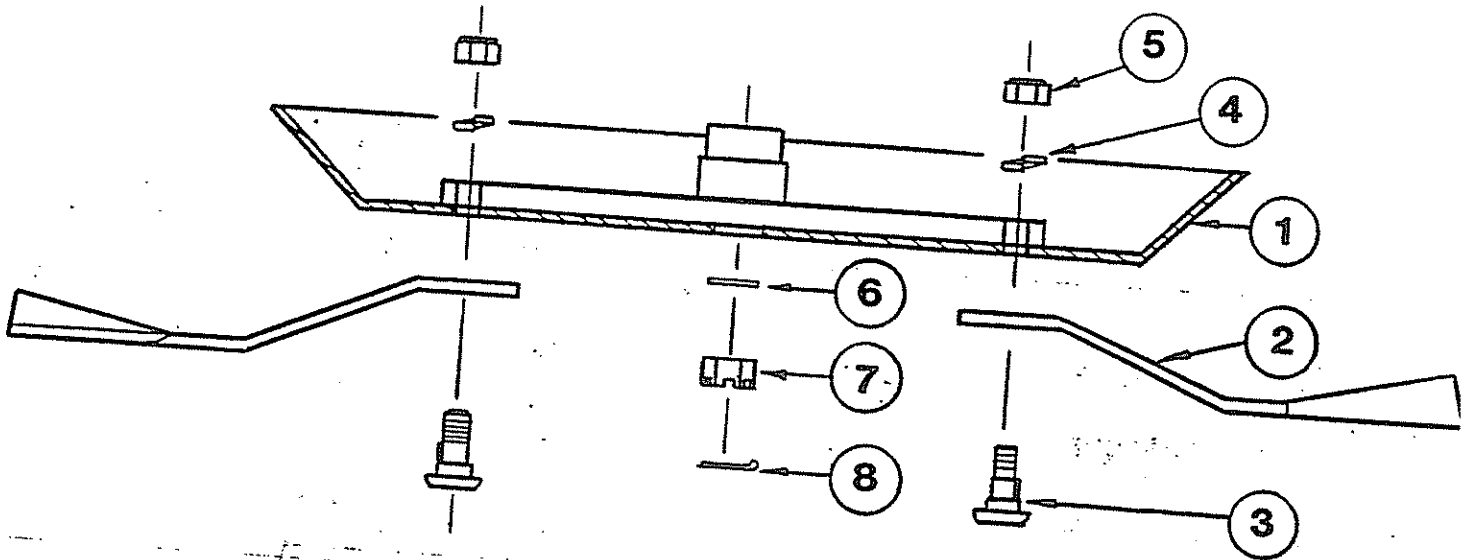

**! DANGER**

**BLADES SHOULD ALWAYS BE REPLACED IN PAIRS. BLADES OF DIFFERENT WEIGHTS CAN CAUSE SERIOUS IMBLANCE AND DAMAGE TO THE MACHINE AND PERSONNEL. WHEN REPLACING BLADES, BLADE BOLTS, BUSHINGS, NUTS AND WASHERS MUST BE CHANGED.**

ITEM	PART NO.	DESCRIPTION	QTY
1	00754654	STUMP JUMPER PAN	
2	00754940	CLKWISE BLADES	1
	00753842	COUNTER CLKWISE BLADES	1
3	00752827	BLADE BOLT	1
4	00748000	LOCKWASHER	2
5	00747900	NUT	2
6	00748547	FLATWASHER	2
7	00606100	NUT	REF
8	00606000	COTTER PIN	REF

# CHAINGUARD ASSEMBLIES

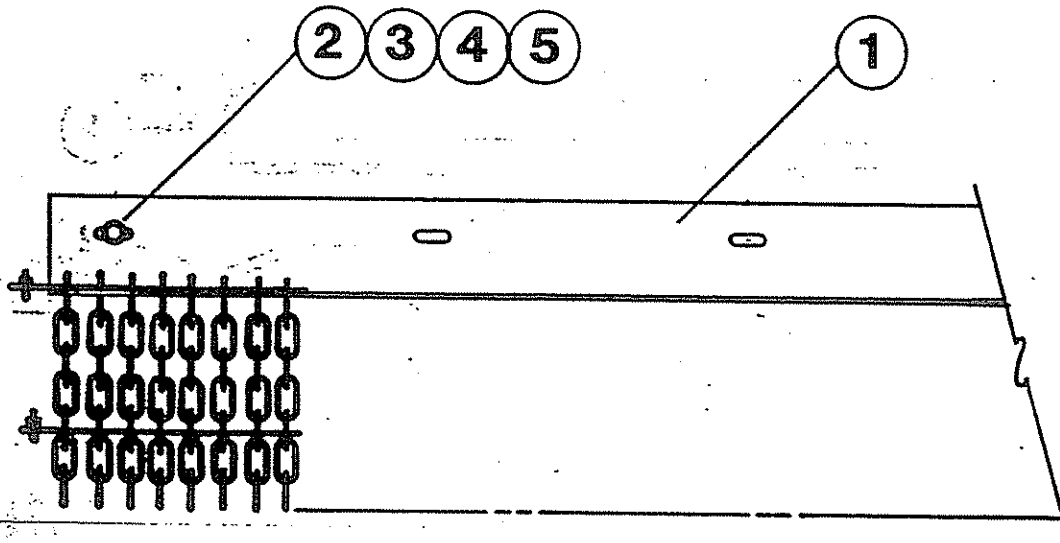

ITEM	PART NO.	DESCRIPTION	QTY
1	00753132	FRONT CHAIN GUARD ASSEMBLY	1
	00753133	FRONT SIDE CHAIN GUARD ASSEMBLY (NOT ILLUSTRATED)	2
	00753136	REAR CHAIN GUARD ASSEMBLY	1
2	00022500	BOLT - FRONT CHAIN GUARD	10
		BOLT - REAR CHAIN GUARD	5
3	00019700	WASHER - FRONT CHAIN GUARD	20
		WASHER - REAR CHAIN GUARD	10
4	00022200	LOCKWASHER - FRONT CHAIN GUARD	10
		LOCKWASHER - REAR CHAIN GUARD	5
5	00999316	NUT - FRONT CHAIN GUARD	10
		NUT - REAR CHAIN GUARD	5

