

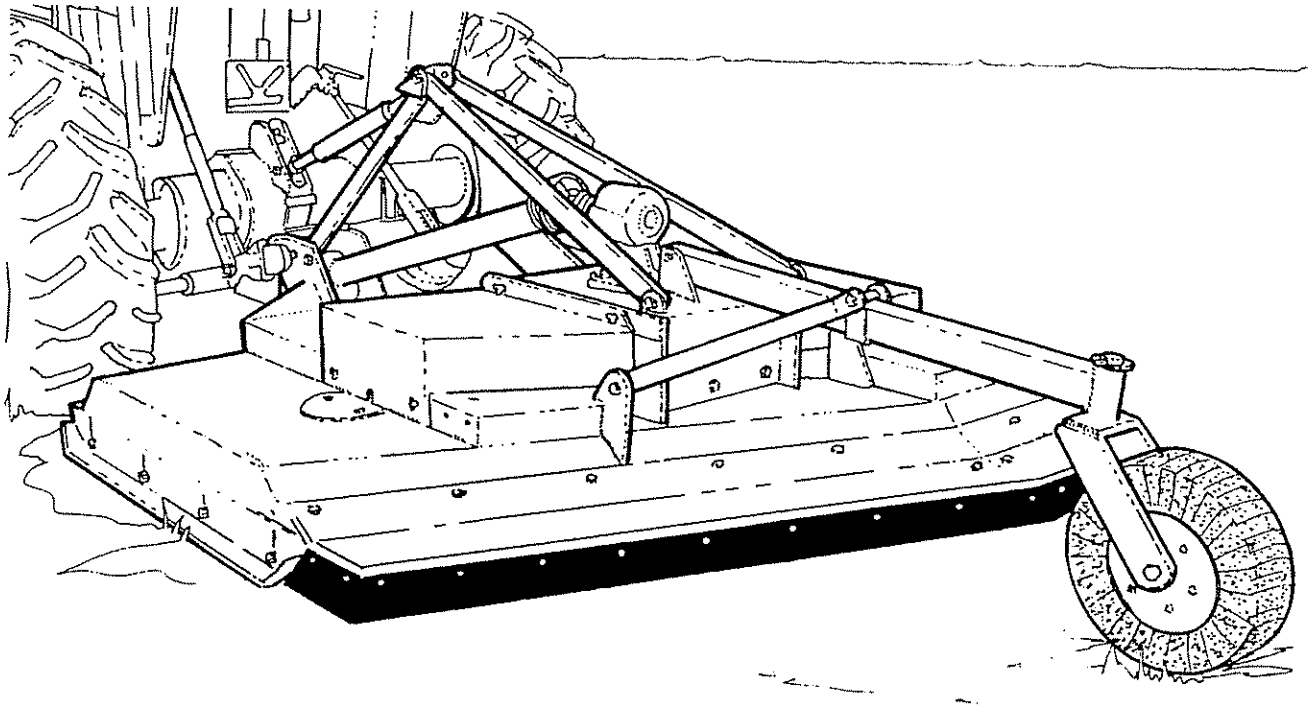

# BD80

Rotary Mower



## OPERATOR'S MANUAL with PARTS LISTING

ALAMO INDUSTRIAL

Post Office Box 549  
Seguin, Texas 78156  
830-372-3551

An Alamo Group Company

© 1997 Alamo Group Inc.

# TO THE OWNER/OPERATOR/DEALER

All implements with moving parts are potentially hazardous. There is no substitute for a cautious, safe-minded operator who recognizes the potential hazards and follows reasonable safety practices. The manufacturer has designed this implement to be used with all its safety equipment properly attached to minimize the chance of accidents.





## BEFORE YOU START!!

Read the safety messages on the implement and shown in your manual. Observe the rules of safety and common sense!



# DANGER

FAILING TO FOLLOW SAFETY MESSAGES AND OPERATING INSTRUCTIONS CAN CAUSE SERIOUS BODILY INJURY OR EVEN DEATH TO OPERATOR AND OTHERS IN THE AREA.

<p>1.</p> 	<p>2. NO RIDERS. NO CHILDREN OPERATORS.</p> 	<p>3. USE SAFETY SHOES, HARD HAT, SAFETY GLASSES, SEAT BELTS, ROPS &amp; OPS</p> 	<p>4. BLOCK UP SECURELY BEFORE WORKING UNDER.</p> 
---	---	---	---

1. Study and understand Operator's Manuals, Safety Decals, and Instructional Decals for tractor and implement to prevent misuse, abuse, and accidents. Practice before operating in a confined area or near passersby.

- Learn how to stop engine suddenly in an emergency. Be alert for passersby and especially children

2. Allow no children on or near folding mower or tractor. Allow no riders on tractor or implement. Falling off may cause serious injury or death from being run over by tractor or mower or contact with rotating blades.

3. Operate only with tractor having Roll-Over Protective Structure (ROPS) and with seat belt securely fastened to prevent injury and possible death from falling off or tractor overturn.

- Personal Protective Equipment such as Hard Hat, Safety Glasses, Safety Shoes, & Ear Plugs are recommended.

4. Block up or support raised machine and all lifted components securely before putting hands or feet under or working underneath any lifted component to prevent crushing injury or death from sudden dropping or inadvertent operation of controls. Make certain area is clear before lowering or folding

5. Before transporting, put Lift Lever in detent or full-lift position. Install Transport Safety Devices securely on folding mowers. Put Booms securely in Transport Rest.



- Folding and Boom Mowers have raised center of gravity. Slow down when turning and on hillsides.

6. Make certain that SMV sign, warning lights, and reflectors are clearly visible. Follow local traffic codes.

7. Never operate with Cutting Head or Folding Section raised if passersby, bystanders, or traffic are in the area to reduce possibility of injury or death from objects thrown by Blades under Guards or mower structure.

8. Before dismounting, secure implement in transport position or lower to ground.

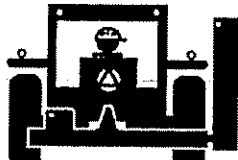
- Put tractor in park or set brake, disengage PTO, stop engine, remove key, and wait until noise of rotation has ceased to prevent crushing by entanglement in rotating parts which could cause injury or death.
- Never mount or dismount a moving vehicle. Crushing from runover may cause serious injury or death.

<p>5. TRANSPORT SAFELY, LOCK UP.</p> 	<p>6. USE SMV, LIGHTS, &amp; REFLECTORS.</p> 	<p>7. DO NOT OPERATE WITH CUTTER OR WING RAISED.</p> 	<p>8. DO NOT MOUNT OR DISMOUNT WHILE MOVING.</p> 
--	--	---	--

022067827

## WARRANTY INFORMATION:

Read and understand the complete Warranty Statement found in this Manual. Fill out the Warranty Registration Form in full and return it within 30 Days. Make certain the Serial Number of the Machine is recorded on the Warranty Card and on the Warranty Form that you retain. The use of "will-fit" parts will void your warranty and can cause catastrophic failure with possible injury or death.

# TABLE OF CONTENTS

	PAGE
SAFETY INFORMATION .....	2-4
DECAL LOCATION .....	5-6
INTRODUCTION .....	7-8
ASSEMBLY .....	9-23
A-frame, Braces, and Hitch Pins .....	9
Tail Wheel .....	10
Check Chains for Lift Model .....	11
Drivelines .....	12-13
Blade Carrier and Blades.....	14
Shields, Guards, and Deflectors .....	15-17
Rear Axle, Leveling Rods, and Lifting Parts .....	18-19
Ratchet Lift Screw .....	20
Lifting Hydraulic Cylinder .....	20
Wheels, Tires, and Hub .....	21
Tongue Attachment .....	22
Mower Preparation .....	23
OPERATION .....	24-32
Preparing the Tractor.....	24
Attaching Cutter to Tractor .....	24
Check PTO Length .....	25
Cutting Height Adjustment .....	26
Slip Clutch Adjustment .....	26
Starting and Stopping Cutter .....	26
Cutting Speed .....	27
Cutting Tips .....	27
Uneven Terrain.....	28
Blade Carriers .....	28
Transporting.....	29
Trouble Shooting .....	30-32
MAINTENANCE .....	33-46
Lubrication Information .....	33
Gearbox .....	34
Tail Wheel.....	34
Universal Joints .....	35
Driveline .....	35
Blade Servicing .....	35
Blade Sharpening .....	35
Blade Removal.....	36
Blade Carrier Removal.....	36
Blade Carrier Installation .....	36
Slip Clutch .....	36-37
Storage.....	37
Gearbox Disassembly and Assembly .....	38-41
Slip Clutch Dissassembly and Assembly .....	42
Driveline Shields .....	43
Torque Chart .....	44
Belt Replacement.....	44
Belt Adjustment .....	44
PARTS SECTION.....	Parts 1
Parts Ordering Guide .....	Parts 2
Parts Table of Contents.....	Parts 3

# SAFETY

## **DANGER**



There are obvious and hidden potential hazards in the operation of this mower. **REMEMBER!** This machine is often operated in rough terrain conditions and in heavy weeds. The Blades of this mower can throw objects for a great distance at very high speeds. Serious injury or even death may occur unless care is taken to insure the safety of the operator, bystanders, or passersby in the area.

## **KEEP CLEAR**

Included here is a list of Safety Messages which should be followed. Serious injury or death may occur unless care is taken to follow these Safety Messages and use good common sense in avoiding hazards.

Equipment should be operated only by those who are responsible and instructed to do so.

## **DANGER**

Read this manual carefully to acquaint yourself with the Rotary Cutter. Working with unfamiliar equipment can lead to accidents.



## **DANGER**



Rotary Mowers are capable under some conditions of throwing objects for great distances (100 yards or more), and causing objects to inflict serious injury or death. Follow safety messages carefully. **STOP MOWING IF PASSERSBY ARE WITHIN 100 YARDS UNLESS:**

Front and Rear Deflectors, or Chain Guards, or Bands are installed and in good, workable condition.  
-Mower sections are running close to and parallel to the ground without exposed Blades;  
-Passersby are outside the existing thrown-object zone;  
-All areas have been thoroughly inspected and all foreign material such as rocks, cans, glass, and general debris has been removed.

**NOTE:** Where there are grass and weeds high enough to hide debris that could be struck by the blades, the area should be inspected and large debris removed, mowed at an intermediate height, inspected closely with any remaining debris being removed, and mowed again at desired final height. (This will also reduce power required, reduce wear and tear on the Mower drivetrain, spread cut material better, eliminate streaking, and make the final cut more uniform.)

## **WARNING**



The Chain Guards, Bands, Flaps, Driveline Shields, and Gearbox Shields should be used and maintained in good working conditions. They should be inspected carefully at least daily for missing or broken cable, chain links, shields, or guards. Missing, broken, or worn items must be replaced at once to reduce the possibility of injury from thrown objects or entanglement.

## **DANGER**



Extreme care should be taken when operating near loose objects such as gravel, rocks, wire, and other debris. Foreign objects should be removed from the site or avoided to prevent machine damage and/or bodily injury or even death.

## **WARNING**



Do not let the Blades turn when the Mower Deck is raised for turning. This exposes the Cutting Blades which creates a potentially serious hazard and could cause serious injury or even death by objects thrown from the Blades.

## **WARNING**



Do not modify or alter or permit anyone to modify or alter this equipment or any of its components or any equipment function without first consulting your Equipment Dealer.

## **WARNING**



The operator and all support personnel should wear hard hats, safety shoes, and safety glasses at all times for protection from injury by falling objects and items thrown by the machine.

# SAFETY

**WARNING**  Before leaving the tractor seat, always engage the brake and/or set the tractor transmission in parking gear. Disengage the PTO, stop the engine, remove the key, and wait for all moving parts to stop. Place the tractor shift lever into a low range or parking gear to prevent the tractor from rolling. Never mount or dismount a moving tractor. Operate the tractor controls from the tractor seat only.

**WARNING**  Many varied objects, such as wire, cable, rope, or chains, can become entangled in the operating parts of the mower head. These items could then swing outside the housing at greater velocities than the blades. Such a situation is extremely hazardous. Inspect the cutting area for such objects before mowing. Remove any like object from the site. Never allow the cutting blades to contact such items.

"WAIT A MINUTE...SAVE A LIFE!"

**DANGER**  Be particularly careful in transport. Turn curves or go up hills only at a low speed and at a gradual steering angle. Make certain that at least 20% of the tractor's weight is on the front wheels to maintain safe steering. Slow down on rough or uneven surfaces.

**WARNING**  Make certain that the "Slow Moving Vehicle" (SMV) sign is installed in such a way as to be clearly visible and legible. Use flashing warning lights and follow all local traffic regulations.

**WARNING**  Periodically inspect all moving parts for wear and replace with authorized service parts if an excessive amount of wear is present.

**WARNING**  Look for loose fasteners, worn or broken parts, and leaky or loose fittings. Make sure all pins have cotter pins and washers. Serious injury may occur from not maintaining this machine in good working order.

**DANGER**  Do not mount or dismount the tractor while the tractor is mowing. Mount or dismount the tractor only when it is completely stopped.

**DANGER**  Never leave the cutter in the raised transport position. Mower could fall causing injury to anyone who might inadvertently be under mower.

**DANGER**  Never clean or adjust PTO-driven equipment with the tractor engine running.

**DANGER**  Never allow riders on either tractor or mower. Falling off can kill.

# SAFETY

## DANGER



Operate the mower only with a tractor equipped with an approved roll-over-protective system (ROPS). Always wear seat belts. Serious injury or even death could result from falling off the tractor-particularly during a turnover when the operator could be pinned under the ROPS for the Tractor.

## DANGER



**NEVER ALLOW CHILDREN TO OPERATE, RIDEON, OR COME CLOSE TO MOWER OR TRACTOR.** Usually, 15-16 year-old children who are mature and responsible can operate the mower with reasonable safety if they have read Operator's Manual, been trained in safe operation of the machine, and are physically large and strong enough to reach and operate controls easily.

## DANGER



Never work under the Mower Deck, the framework, or any lifted component unless the mower is securely supported or blocked up to prevent sudden or inadvertent falling which could cause serious injury or even death.

## WARNING



Never operate the tractor and mower until you have read and completely understand this manual, the Tractor Operator's Manual, and each of the Safety Messages found on the tractor and mower.

## WARNING



Always maintain the safety decals in good readable condition. If a decal becomes torn, painted over, or otherwise illegible, order replacement decals immediately.

## WARNING



Do not turn sharp enough to get severe "knocking" or vibration in the Driveline which will cause accelerated wear and breakage of drive train components which may cause injury from the seperated Driveline sections.

## DANGER



Make sure the PTO shield is installed when using PTO-driven equipment, and always replace the PTO shield if damaged.

## CAUTION! **PROLONGED EXPOSURE TO LOUD NOISE MAY CAUSE PERMANENT HEARING LOSS!**



Tractors with or without Mowers attached can often be noisy enough to cause permanent, partial hearing loss. We recommend that you wear hearing protection on a full-time basis if the noise in the Operator's position exceeds 80db. Noise over 85db on a long-term basis can cause severe hearing loss. Noise over 90db adjacent to the Operator over a long-term basis may cause permanent, total hearing loss. Note: Hearing loss from loud noise [from tractors, chain saws, radios, and other such sources close to the ear] is cumulative over a lifetime without hope of natural recovery.

In addition to the design and configuration of this implement, including Safety Signs and Safety Equipment, hazard control and accident prevention are dependent upon the awareness, concern, prudence, and proper training of personnel involved in the operation, transport, maintenance, and storage of the machine. Refer also to Safety Messages and operation instruction in each of the appropriate sections of the Tractor and Mower Manuals. Pay close attention to the Safety Signs affixed to the Tractor and Mower.

# DECALS

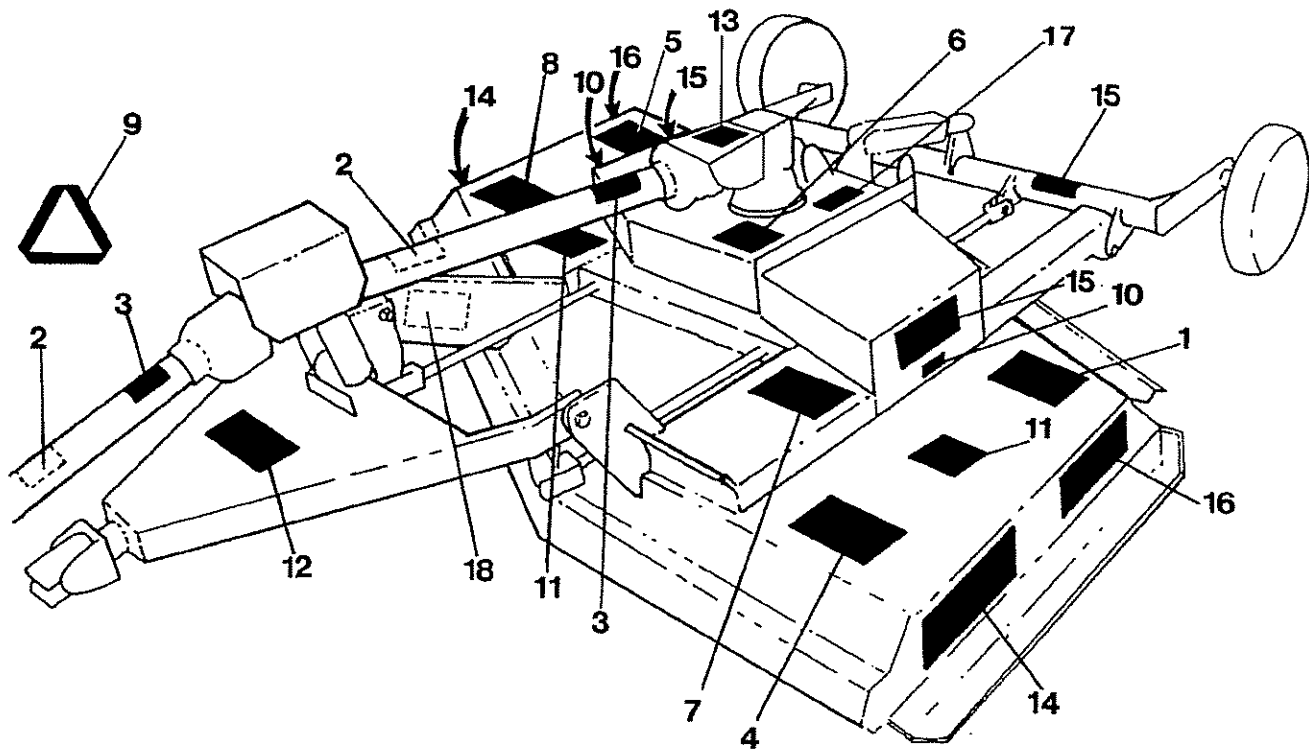

ITEM	PART NO.	QTY	TYPE	DECAL DESCRIPTION
1	00749117	1	DANGER	Multiple Hazard, 8 Pictographs
2	00756004	1 (2)	DANGER	D/L Shield Missing, Do Not Oper.
3	00756005	1 (2)	DANGER	Rotating D/L, Entanglement
4	00756007	1	WARNING	Use/Repair Shields & Guards
5	00756485	1	DANGER	Cutting Blades, Thrown Objects
6	00756494	1	DANGER	Driveline Hazards, 540 RPM
7	00758194	1	WARNING	V-Belt Nip Point
8	02925100	1	CAUTION	Genuine Parts, Rotary Mowers
9	03200347	*	REFLECTR	SMV Emblem
10	000678	2	INSTRUC	Grease Fitting Inside
11	D137	2	INSTRUC.	Counter-Clockwise Blade Rotation
12	D102	(1)	INSTRUC.	Drawbar-to-PTO Distance
13	00763613	1	INSTRUC.	Slip Clutch
14	00758206	1	Alamo Group Logo	3-7/8 x 14-1/16
15	02960766	(2)	Alamo Group Logo	4 x 5
16	00758193	2	BD80 Name Decal Only	
17	00756059	1	DANGER	Oil Leak Detection
18	NFS	1	Serial Plate	

\* Furnished by tractor manufacturer  
( ) Pull Models Only

# DECALS

**! DANGER**

**ROTATING DRIVELINE CONTACT CAN CAUSE DEATH KEEP AWAY!**

DO NOT OPERATE WITHOUT—

- ALL DRIVELINE, TRACTOR AND EQUIPMENT SHIELDS IN PLACE
- DRIVELINES SECURELY ATTACHED AT BOTH ENDS
- DRIVELINE SHIELDS THAT TURN FREELY ON DRIVELINE

00756005

3 - 00756005

**GREASE FITTING INSIDE**

10 - 000678

**! DANGER**

**SHIELD MISSING DO NOT OPERATE**

**! DANGER**

**SHIELD MISSING DO NOT OPERATE**

**! DANGER**

2 - 00756004

**! DANGER**

1. MAKE CERTAIN DRIVELINES ARE OF THE CORRECT LENGTH AND SECURELY ATTACHED. DRIVELINE SEPARATION AND/OR PTO STUB SHAFT FAILURE CAN CAUSE INJURY OR DEATH. (See Operator's Manual for procedure.)

2. MAKE CERTAIN THAT DRIVELINE SHIELDS ARE INSTALLED CORRECTLY AND TURN FREELY TO PREVENT INJURY OR DEATH FROM ENTANGLEMENT

3. IF DRIVELINE SHIELDS HAVE TETHER CHAINS, ATTACH TETHER CHAINS SECURELY TO MOWER AND TRACTOR TO PREVENT SHIELD ROTATION, BELL AND/OR SHIELD FAILURE AND SERIOUS INJURY OR DEATH.

4. 540 PTO RPM UNLESS SPECIFICALLY MARKED OTHERWISE.

00756494

6 - 00756494 (See page 43 for enlargement)

02925100

**! CAUTION**

**ALAMO**

For your Safety and to Guarantee Optimum Product Reliability, Always use Genuine Alamo Replacement Parts. The use of Inferior Replacement Parts may cause premature or Catastrophic Failure which could result in Serious Injury or Death. If you have any Questions concerning the Repair Parts you are using, Contact Alamo Group, P.O. Box 549, Seguin, Texas 78156.

8 - 02925100

**! DANGER**

CUTTING BLADES      THROWN OBJECTS

**KEEP AWAY - ROTATING BLADES**

SERIOUS INJURY OR DEATH CAN RESULT FROM THROWN OBJECTS OR BLADE CONTACT.

- \* STOP MOWING IF PERSONS ARE NOT CLEAR OF THROWN OBJECTS.
- \* DO NOT STAND ON OR NEAR MACHINE WHEN IN OPERATION.
- \* DO NOT OPERATE WITH DEFLECTORS OR GUARDS REMOVED.

5 - 00756485 (Enlarged on page 14)



**BD 80**

16- 00758193

**IMPORTANT**

REQUIRED FOR JACK SHAFT UNIT SUGGESTED FOR STANDARD SHAFT

TONGUE      DRAWBAR

12-D102 (See page 22 for enlargement)

**BLADE ROTATION**

11 - D137

**! WARNING**

USE PAPER OR CARDBOARD TO CHECK FOR LEAKS. NEVER USE YOUR HAND. IF OIL PENETRATES SKIN, GANGRENE OR OTHER SERIOUS INJURY COULD OCCUR. GET IMMEDIATE MEDICAL ATTENTION. See Operator's Manual.

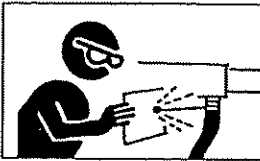

17 - 00756059

**! WARNING**

DO NOT OPERATE WITH BELT SHIELD REMOVED. FINGER(S) MAY BE PINCHED OFF IF CAUGHT BETWEEN V-BELT AND PULLEY.

00758194

7 - 00758194



14-00758206

**ATTENTION!**

Do not operate PTO until ALL Slip Clutches are properly adjusted and checked to make certain that NONE ARE FROZEN and that ALL WILL SLIP under excessive load. See Operator's Manual for complete instructions.

00753613



# INTRODUCTION

This Rotary Mower is designed with care and built with quality materials by skilled workers. Proper assembly, maintenance, and operating practices, as described in this manual, will help the owner/operator get years of satisfactory service from the machine.

The purpose of this manual is to familiarize, instruct, and train. The Assembly Section instructs the owner/operator in the correct assembly of the Mower using standard and optional equipment. The Parts Listing section is designed to familiarize the owner/operator with replaceable parts on the Mower. This section provides exploded assembly drawings of each mower component illustrating each piece and the corresponding part number.

Careful use and timely service saves extensive repairs and costly downtime losses. The Operation and Maintenance Sections of the manual train the owner/operator how to work the Mower correctly and attend to appropriate maintenance. The Trouble Shooting Guide helps diagnose difficulties with mower and offers solution to the problems.

Safety is of primary importance to the owner/operator and to the manufacturer. The first section of this manual includes a list of Safety Messages, that, if followed, will help protect the operator and bystanders from injury or death. Many of the Safety Messages will be repeated throughout the manual. The owner/operator/dealer should know these Safety Messages before assembly and be aware of the hazards of operating this mower during assembly, use, and maintenance. The Safety Alert Symbol combined with a Signal Word, as seen below, is intended to warn the owner/operator of impending hazards and the degree of possible injury faced when operating this machine.

**CAUTION** The lowest level of Safety Message; warns of possible minor injury. Decals located on the Mower with this Signal Word are Black and Yellow.



**WARNING** Serious injury or possible death! Decals are Black and Orange.



**DANGER** Imminent death/critical injury. Decals are Red and White.



## ATTENTION OWNER/OPERATOR

### BEFORE OPERATING THIS MACHINE:

1. Carefully read the Operator's Manual, completely understand the Safety Messages and instructions, and know how to operate correctly both the tractor and Mower.
2. Fill out the Warranty Card in full. Be sure to answer all questions, including the Serial Number of the Mower. Mail promptly using the return envelope included with the Operator's Manual.

*NOTE: Warranties are honored only if completed "Owner Registration and Warranty" forms are received by Alamo Group within thirty days of delivery of the mower.*

3. Record the Mower Model and Serial Numbers on the Warranty page at the end of the Operator's Manual. Keep this as part of the permanent maintenance file for the Mower.

# INTRODUCTION

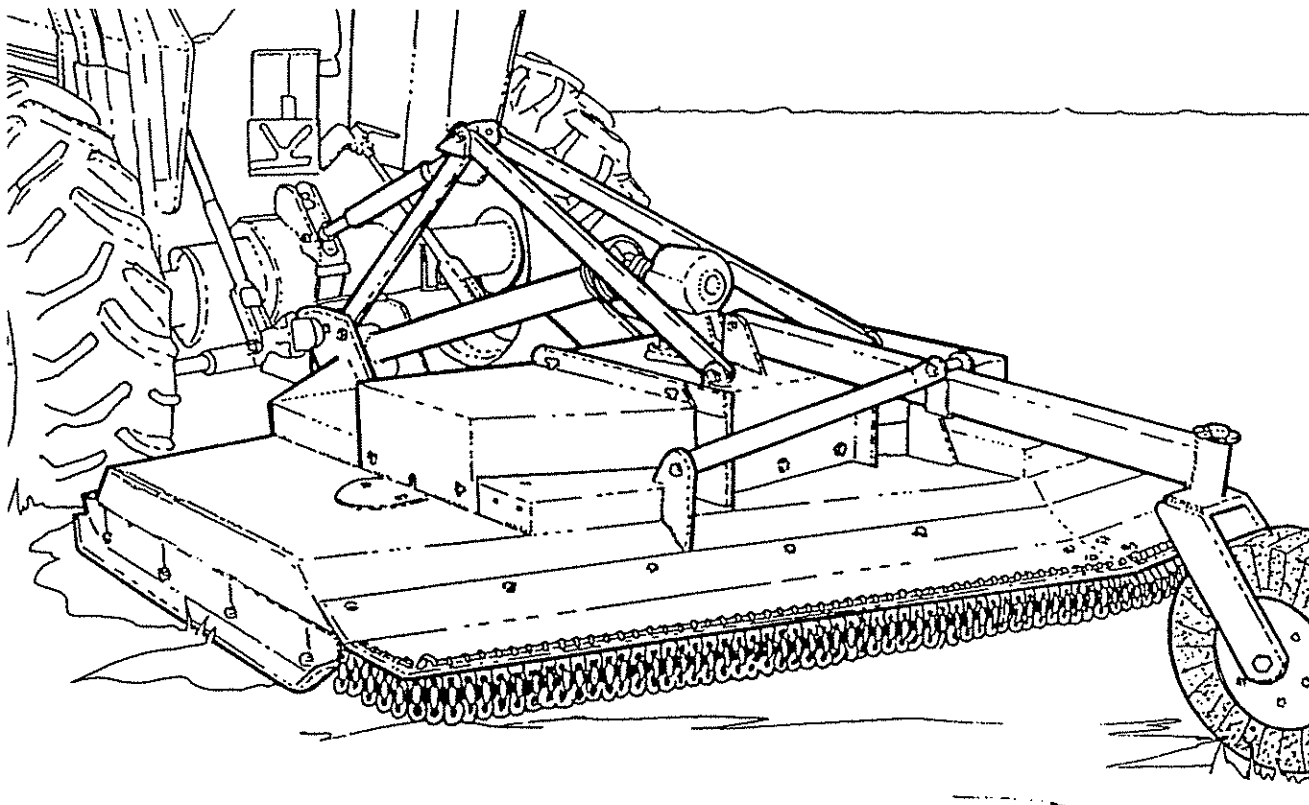

These mowers are available in lift-type and pull-type. These rugged Mowers are designed for medium-duty work. They can mow pastures, cut brush up to 1-1/2" in diameter, and control grass and weeds on highways or industrial sites.

## **DANGER**



For Non-Agricultural use, OSHA, ASAE, SAE, and ANSI standards require the use of Chain Guards, Deflectors, or Solid Skirts at all times. The Mower manufacturer strongly recommends the use of Chain Gaurds, Deflectors, or Solid Skirts for Agricultural purposes as well to reduce the risk of property damage, serious bodily injury, or even death from objects thrown out by or from contact with the Cutting Blades.

This 80" machine requires a minimum of 30 HP with adequate front end weight.

## **WARNING**



At least 20% of the tractor's total weight must be on the front tires with the Mower lifted to provide adequate traction for safe steering under good conditions. Slow down on hills, rough terrain, and curves.

Front and rear, and left and right are determined by the normal direction of travel (the same as on your automobile).

# ASSEMBLY

## A-FRAME, BRACES, AND HITCH PINS (Figure 1)

1. The three-point hitch A-Frames (1) attach to the lift lugs (2) on the mainframe with  $3/4 \times 2$  bolts and locknuts (3).
2. The brace member (with top hitch assembly and bushing (4) installed between brace members (5)) are installed between A-Frame uprights with  $3/4 \times 6$  bolt and locknut (6). The brace members (5) attach to lugs on rear of frame (7) with two  $3/4 \times 2$  bolts and locknuts. Tighten all five bolts securely.
3. Hitch pins for Cat II (8) attach to top front holes in lift lugs as shown with  $7/8$ " NFT nut. Tighten nut to 150 ft.lbs. min. Hitch pins for Cat I attach with pins to the INSIDE.

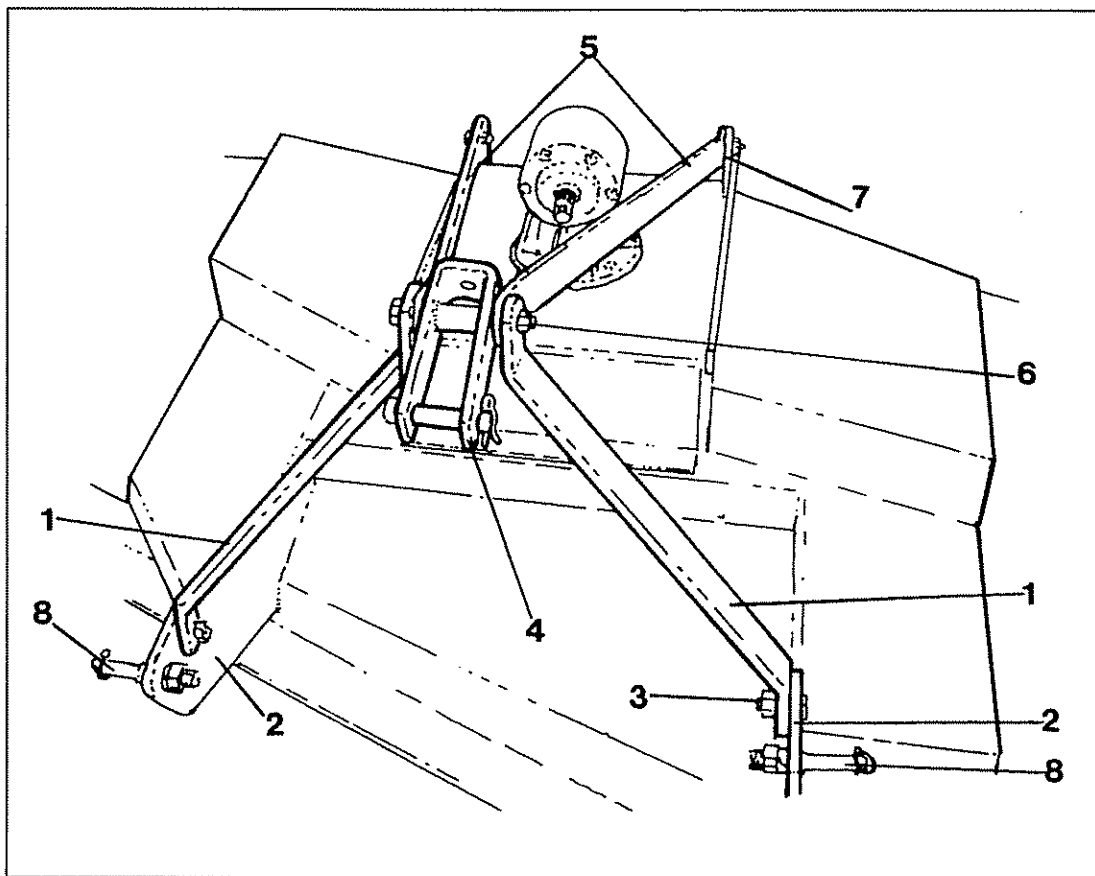

FIGURE 1

# ASSEMBLY

## TAIL WHEEL (Figure 2)

Attach tailwheel beam (1) to anchor (2) on gearbox mounting assy with 5/8 x 3-1/2 bolt and locknut (3). Tighten locknut securely but not excessively. Attach tail wheel adjustment brackets (4) to lugs (5) on rear of frame with 5/8 x 2 bolts and locknuts.

Adjust tail wheel to desired height by loosening 5/8 x 4-1/2 bolt (7) in support clamp (8) and sliding clamp forward on the beam to raise tail wheel (reduce height of cut). Slide clamp to the rear to lower tail wheel (increase height of cut). Tighten all four bolts and locknuts securely.

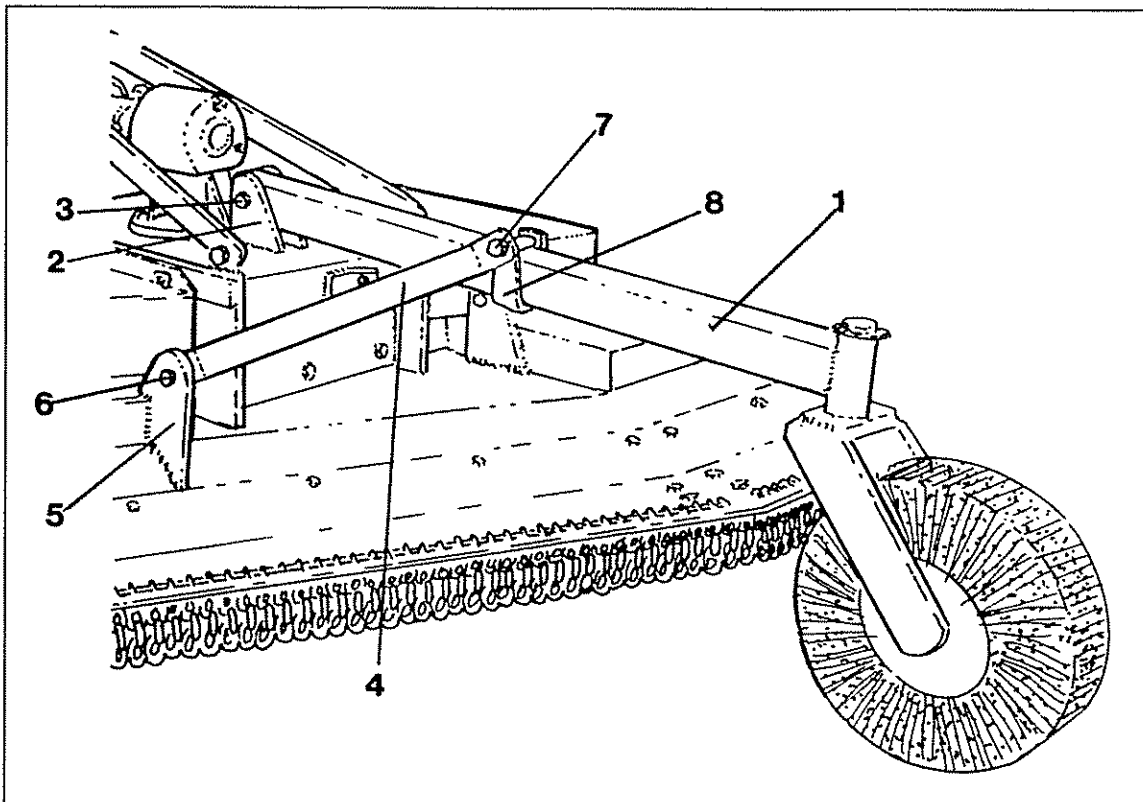

FIGURE 2

# ASSEMBLY

## CHECK CHAINS (EXTRA EQUIPMENT) FOR LIFT-MODELS (Figure 3)

Check Chains are available for attachment to front of Mower as an accessory. Check chains are used to control cutting height and especially allow Mower to be lowered to the same preset cutting height effortlessly.

Install lower end of check chain (4) to hitch ears (6) through lower holes (7) using bolts, nuts and lockwashers(8). Tighten securely.

Install chain lugs (3) on either side of tractor top link mounting (5) using bolt or pin of required diameter and length. Cat I kit requires a 3/4" diameter bolt. Cat II kit requires a 1" diameter bolt. Install top end of check chains in brackets (3).

Cutting height is then set by placing proper chain link in keyhole slot. Cutting height is easily adjustable by hooking chain higher or lower in the keyholes in chain lug (3).

### CAUTION



For additional safety in transport, raise mower as high as possible without having driveline hit deck and shorten check chains as much as possible to prevent inadvertent falling in transport.

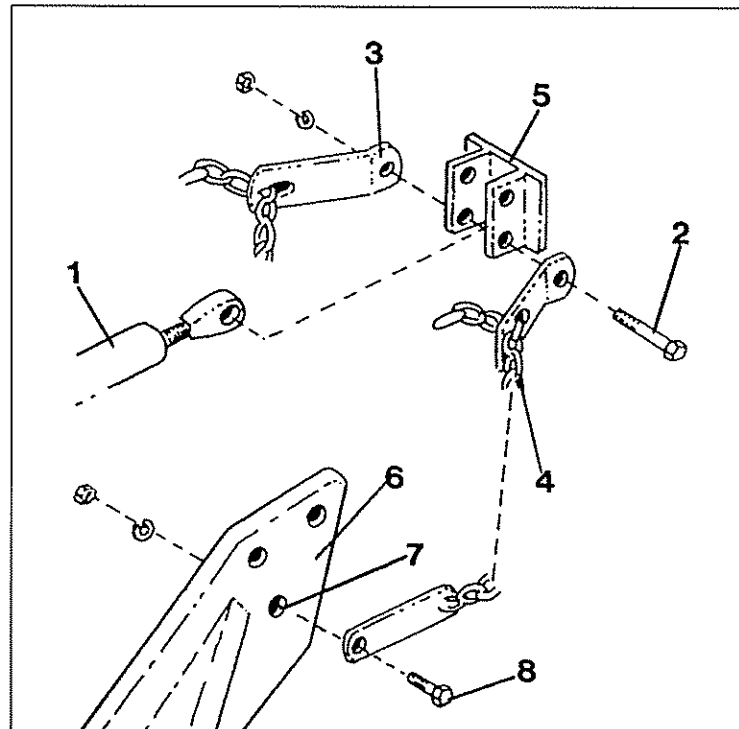

FIGURE 3

# ASSEMBLY

## DRIVELINES

Before starting assembly, make certain that all paint, dirt, and grease are removed from splines and that the slip joint grease fittings align properly with holes in shields. File or grind off any burrs or knicks to ease assembly and apply a light coat of grease to splines and assemble. Do not assemble a driveline without a shield. Entanglement in rotating shafts can kill.

### A. Lift-type Drivelines

1. Attach the slip clutch end of the implement input driveline to the gearbox input shaft (IIC) securely. Make certain that the slip clutch is fully onto the input shaft splines and that the spring-loaded locking collar is completely seated. See Figure 4.

**NOTE:** Shield removed to show detail only, Mower should **NEVER** be operated without shield in place.

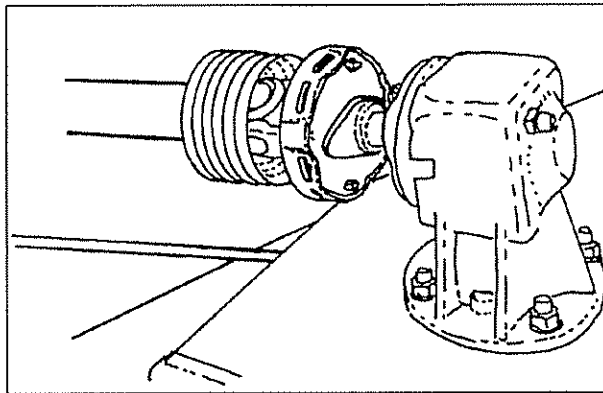
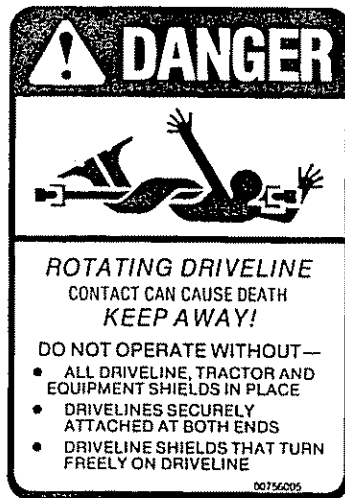

FIGURE 4



# ASSEMBLY

## DRIVELINES

### B. Pull-type Driveline

1. Attach the slip clutch end of the jackshaft driveline to the gearbox input shaft (IIC) securely. Make certain that the slip clutch is fully onto the input shaft splines and that the spring-loaded locking collar is completely seated. See **Figure 6**.
2. Put 1-3/8-21 splined end of jackshaft through bearing in jackshaft stand. Assemble stand to tongue with two bolts. See **Figure 7**.
3. Assemble 1-3/8-21 end of implement input driveline onto jackshaft stub shaft. Make certain yoke is fully seated and that slide seated in place. See **Figure 8**.
4. Attach shield to top of jackshaft stand with wing nut. Tighten securely. See **Figure 8**.

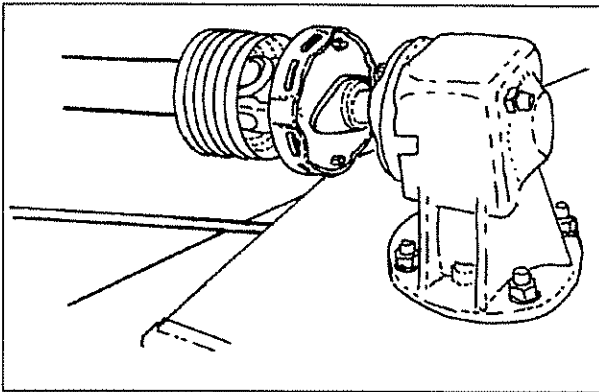

FIGURE 6

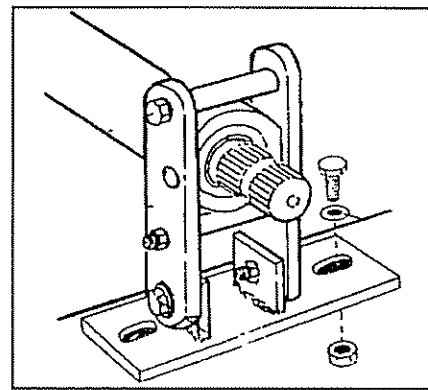

FIGURE 7

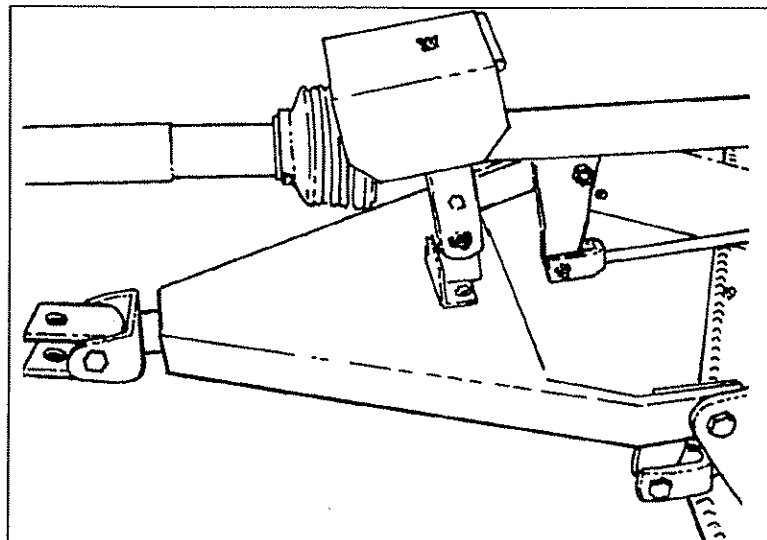

FIGURE 8

# ASSEMBLY

## BLADE CARRIERS AND BLADES

These mowers are shipped with the Gearbox already assembled to the deck. The optional Blade Bar or Pan Blade Carrier with Combination Blades is attached at the factory as well.

Secure the mainframe vertically and allow free access to the Gearbox output shaft for safe installation of the Blade Carrier and Blades. Tighten nut on Gearbox output shaft/blade carrier hub 1 to 350 ft/lbs. Insert and spread cotter securely. See Figure 9.

**NOTE:** Blade Bolts 2 are grade 8, heat-treated, have right-hand threads. Tighten to 250 ft/lb torque. Make certain that bushing is in blade before installing bolt.

**NOTE:** Combination updraft Blades will handle brush up to 1-1/2" as well as straight blades and will also help pick up trampled down grass for smoother cutting.

**WARNING** Use particular care when working on Blade Carriers. Blades are heavy and sharp and can pivot and cause severe injury to arms and hands. DO NOT REPLACE BLADE BOLTS with anything except Rhino grade 8, alloy heat treated hex bolts.

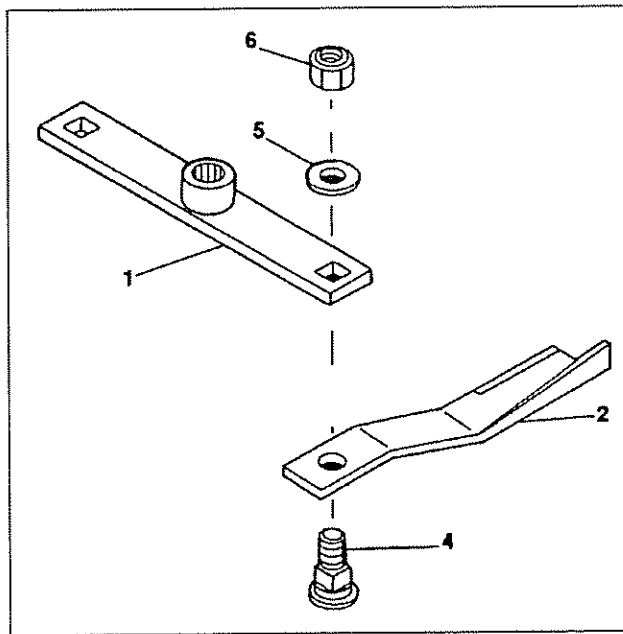

FIGURE 9

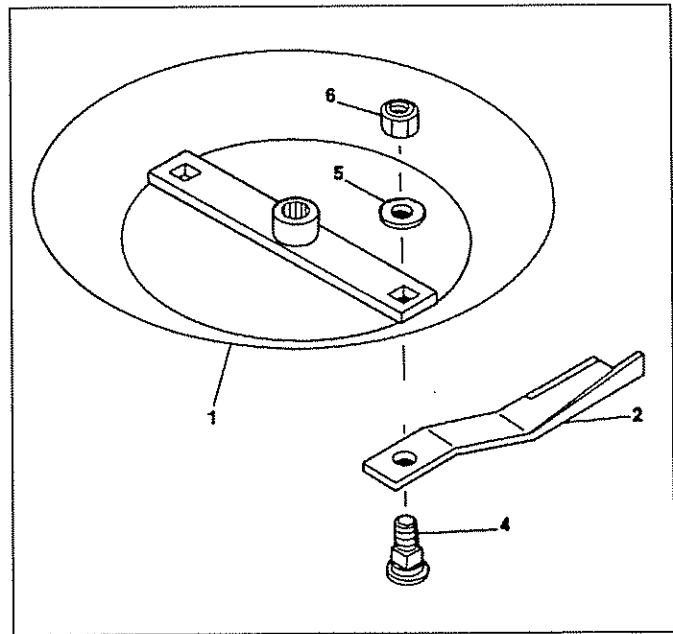

FIGURE 10



# ASSEMBLY

## SHIELDS, GUARDS, AND DEFLECTORS

Shields, Guards, and Deflectors are provided for the protection of the operator and bystanders. The Manufacturer strongly recommends the use of Protective Shielding at all times. Do not operate the machine without Shields in place.

### DANGER

Make certain that all Driveline Shields are installed and turn freely and that the tractor PTO shield is replaced before starting the PTO.

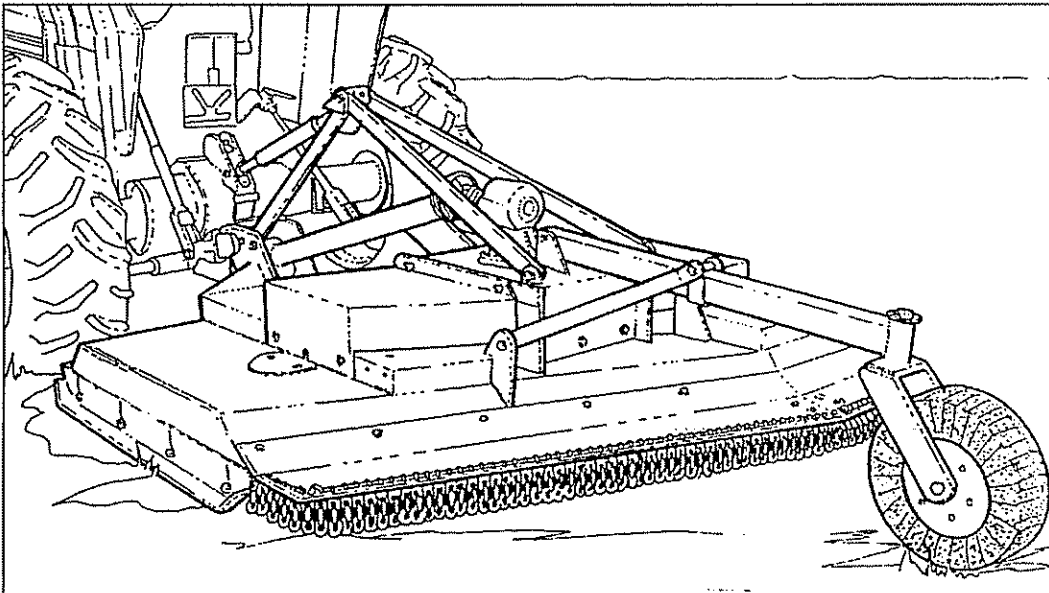
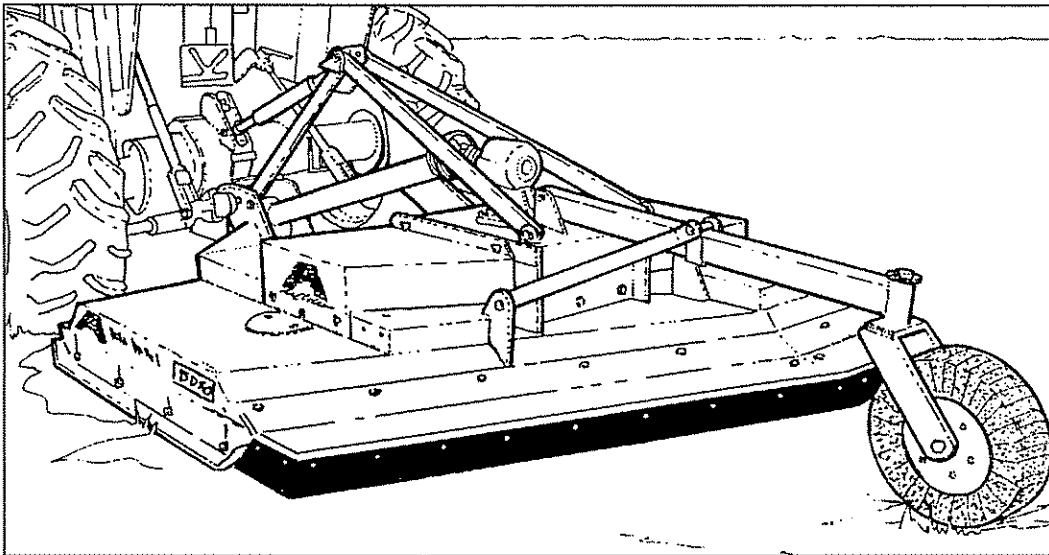

# ASSEMBLY

## CHAIN GUARDS AND RUBBER FABRIC DEFLECTOR ASSEMBLIES

### A. Rubber Fabric Deflectors (Standard Equipment)

#### Front (See Figure 11)

1. Attach the front right and left deflector with (10) - 1/2" x 1-1/4" bolts, (10) - 1/2" flatwashers and (10) - 1/2" locknuts.

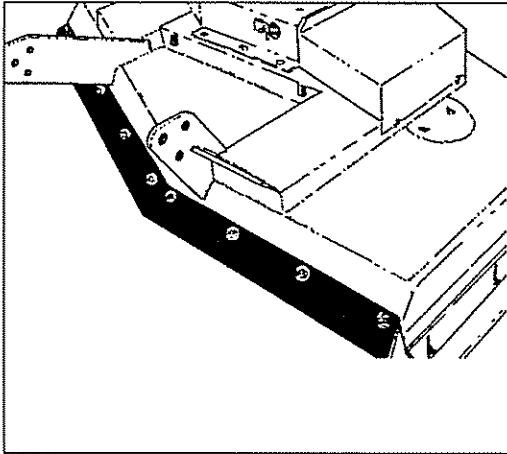

FIGURE 11

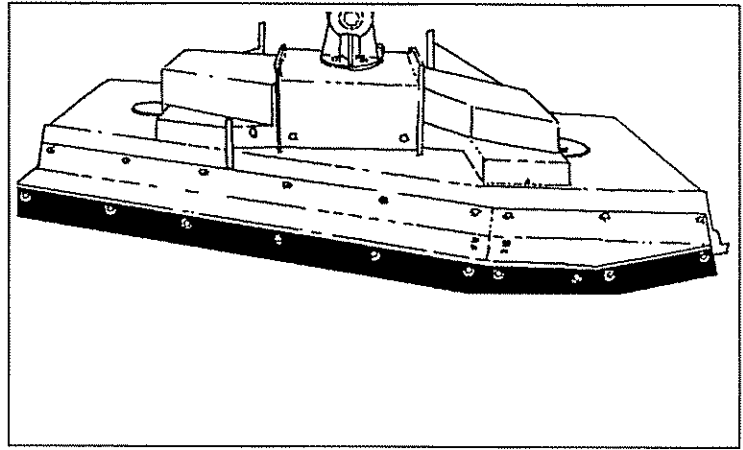

FIGURE 12

#### Rear (See Figure 12)

1. Attach the right and left deflector mount to rear of mower with (10) - 1/2" x 1-1/4" bolts, (10) - 1/2" flatwashers and (10) - 1/2" locknuts.
2. Attach the deflector mount angle to the left debris deflector mount with (2) - 1/2" x 1-1/4" bolts, (2) - 1/2" flatwasher and (2) - 1/2" locknuts.
3. Attach the right and left deflector mounts together with the rear chainguard tie bar using (4) - 1/2" x 1-1/4" bolts, (4) - 1/2" flatwashers, and (4) - 1/2" locknuts.
4. Attach the right and left deflector with (14) - 1/2" x 1-1/4" bolts, (14) - 1/2" flatwashers and (14) - 1/2" locknuts.
5. Attach the rear left side deflector with (2) - 1/2" x 1-1/4" bolts, (2) - 1/2" flatwashers and (2) - 1/2" locknuts.



## WARNING

WHENEVER THIS MACHINE IS OPERATED IN ANY AREA WHERE THROWN OBJECTS COULD INJURE PERSONS OR PROPERTY, SAFETY SHIELDING MUST BE INSTALLED AND IN GOOD REPAIR TO REDUCE THE POSSIBILITY OF INJURY FROM THROWN OBJECTS.

CHAIN GUARDS, SOLID BANDS, RUBBER FLAPS, AND OTHER GUARDS ARE SUBJECT TO WEAR AND LOST OR BROKEN PIECES. IT IS THE OPERATOR'S RESPONSIBILITY TO SEE THAT THESE ITEMS OF SAFETY EQUIPMENT ARE REPAIRED AND/OR REPLACED AS SOON AS DAMAGE OCCURS, OR YOU WILL BE OPERATING MACHINE THAT IS IN AN UNSAFE CONDITION.

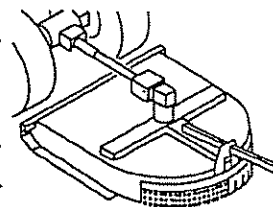

00756007

# ASSEMBLY

## CHAIN GUARDS AND RUBBER DEFLECTOR ASSEMBLY

### B CHAIN GUARD (EXTRA EQUIPMENT)

Front

1. Attach the right and left chain guard assemblies to the mower with (10) - 1/2" x 1-1/4" bolts, (10) - 1/2" flatwashers, and (10) - 1/2" locknuts as shown in **figure 13**.

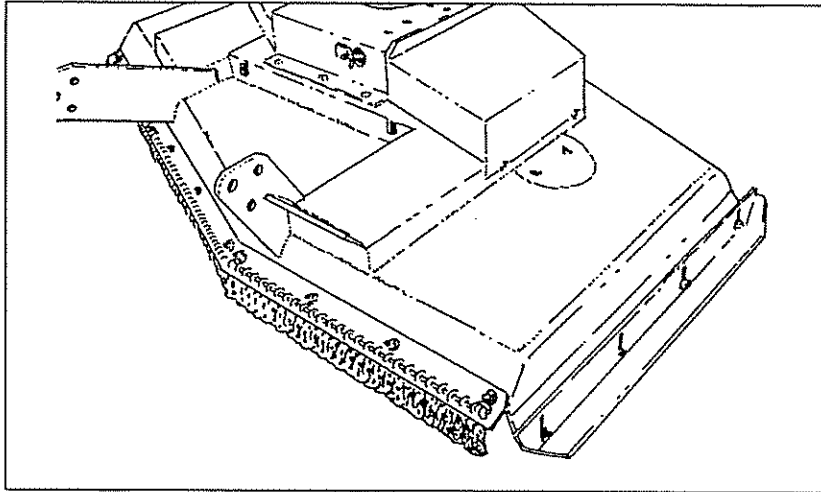

FIGURE 13

Rear

1. Attach the right and left chain guard assemblies to the mower with (9) - 1/2" x 1-1/4" bolts, (9) - 1/2" flatwashers and (9) - 1/2" locknuts as shown in **figure 14**.
2. Attach the right and left chain guard assemblies together with the rear chain guard tie bar using (4) - 1/2" x 1-1/4" bolts, (4) - 1/2" flatwashers and (4) - 1/2" locknuts as shown in **figure 14**.

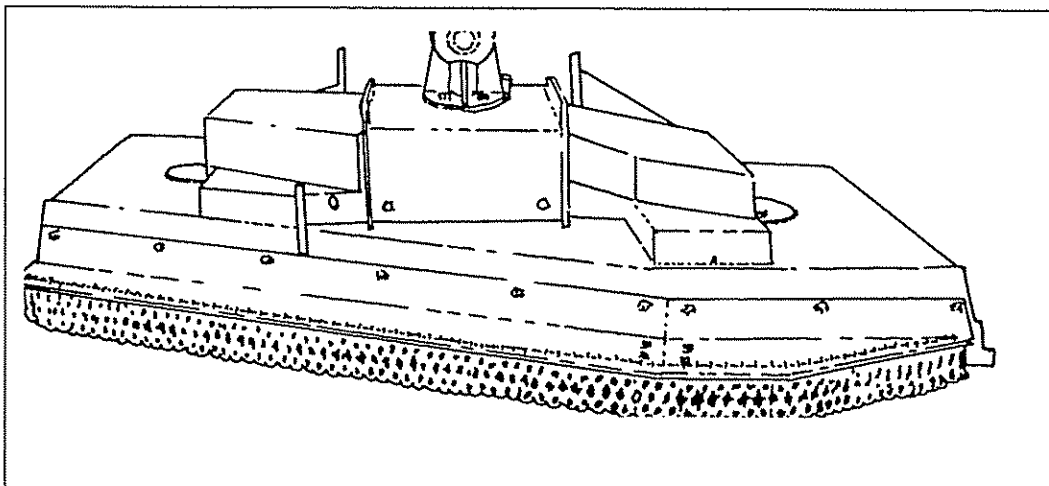

FIGURE 14

# ASSEMBLY

## REAR AXLE, LEVELING RODS, AND LIFTING PARTS

### A. Rear Axle Pivot Angles

Attach the right and left axle pivot angle to the top of the mower deck with (5) - 5/8" x 1-1/2" bolts (2 on the right and 3 on the left). See **Figure 15 & 16**.

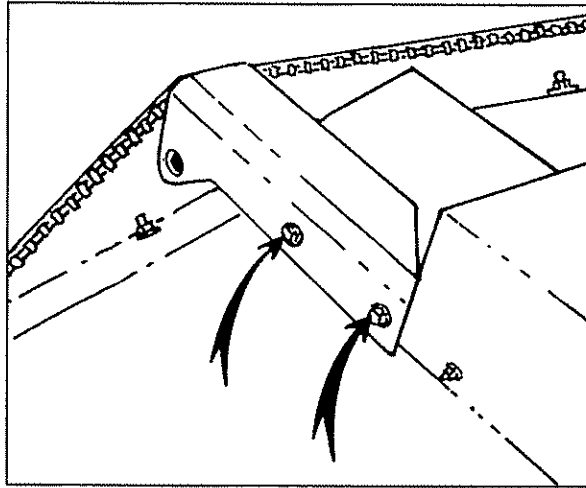

FIGURE 16

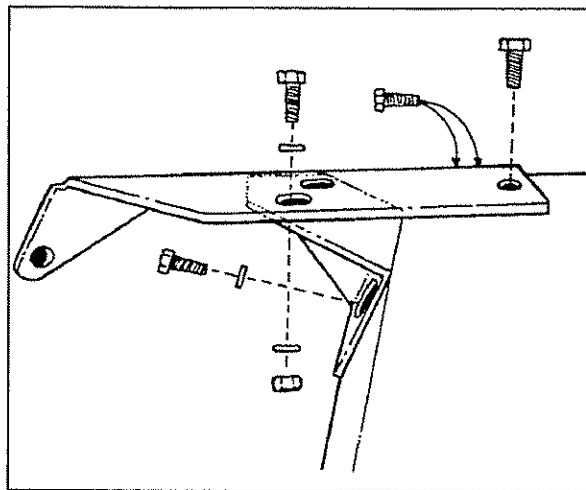

FIGURE 17

**NOTE:** The nuts for the attaching bolts are welded to the inside of the mower frame.

# ASSEMBLY

## REAR AXLE, LEVELING RODS, AND LIFTING PARTS

### B. LEVELING RODS

Slide long level lift rods (Item 1, **Figure 17**), through holes in mower deck. Attach jam nuts and adjusting nut to long level rods (Item 2 and 3, **Figure 17**). Attach the short level rods (item 4) to adjusting nuts.

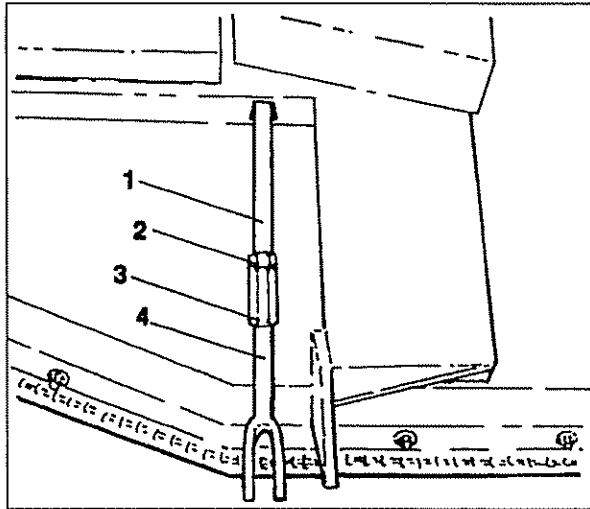

**FIGURE 17**

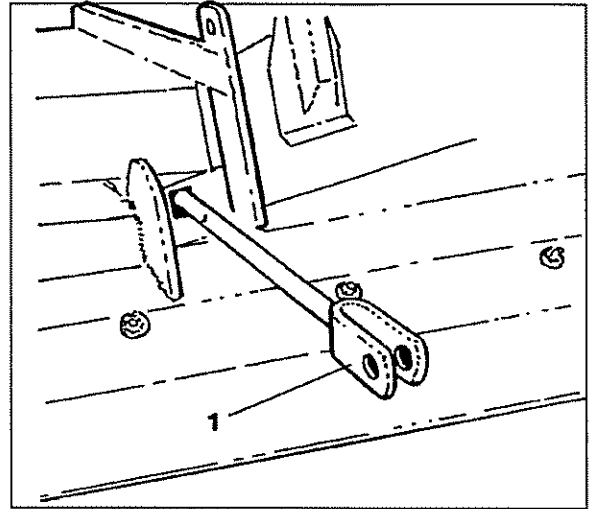
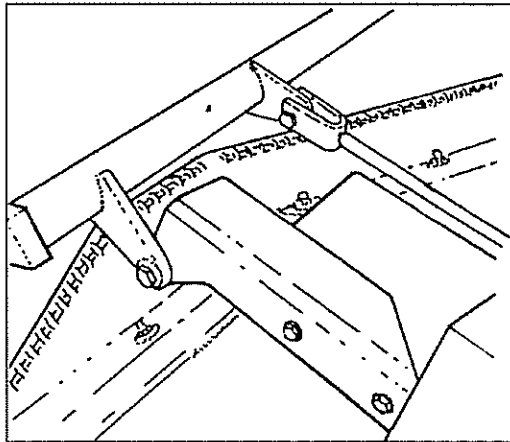

**FIGURE 18**

### C. REAR AXLE

1. Attach the rear axle to the right and left axle pivot angles with (2) -  $3/4$ " x  $2-3/4$ " bolts, (2) - bushings, and (2) - locknuts. Tighten securely. See **Figures 19 & 20**.

2. Attach the leveling rods to the rear axle with (2) -  $3/4$ " x  $2-3/4$ " bolts, (2) - bushings, and (2) - locknuts. Tighten securely. See **Figure 29 & 20**.



**FIGURE 19**

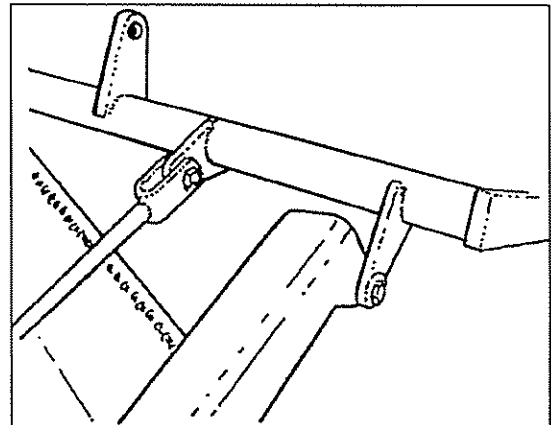

**FIGURE 20**

# ASSEMBLY

## D. RATCHET LIFT SCREW (OPTIONAL)

1. The ratchet lift screw attaches on one end to the long lug on the rear axle. The other end of the lift screw attaches to lug behind the center gearbox. Use hardware provided with lift screw. See **Figure 21**. Final adjustment of lift screw is made later in the "Operation" section.

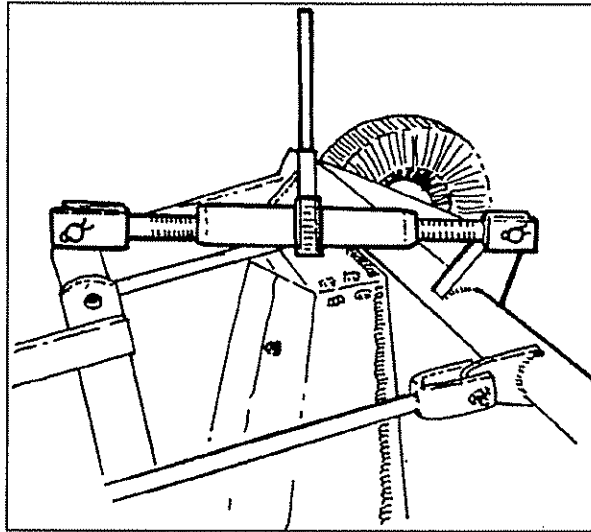

FIGURE 21

## E. LIFTING HYDRAULIC CYLINDER (OPTIONAL)

1. The lifting hydraulic cylinder attaches on one end to the long lug on the rear axle and the other end of the lifting hydraulic cylinder attaches to lug behind the center gearbox. Use hardware provided with hydraulic cylinder. Make certain the hardware is attached securely. See **Figure 22**.

2. Attach hydraulic fitting to cylinder. Coat all hydraulic threads with sealant. **DO NOT USE THREAD TAPE.** Tighten securely. (**DO NOT OVERTIGHTEN, THE TAPER THREAD CAN CRACK THE CASTING IF OVERTIGHTENED**).

3. Run hose through hose supports (**figure 23**) and attach to outlet on tractor. (Note: Hose couplers are not furnished. Obtain locally from your dealer to match your tractor.)

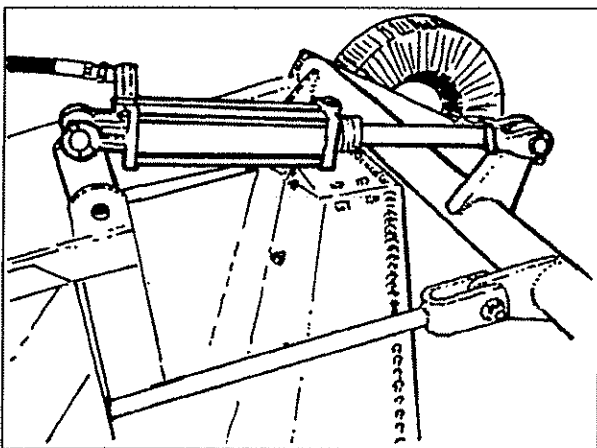

FIGURE 22

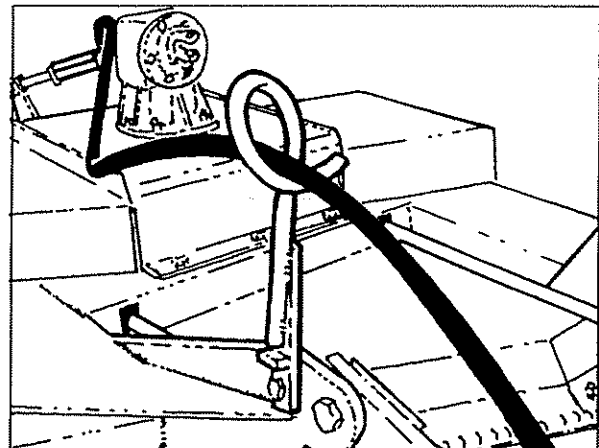
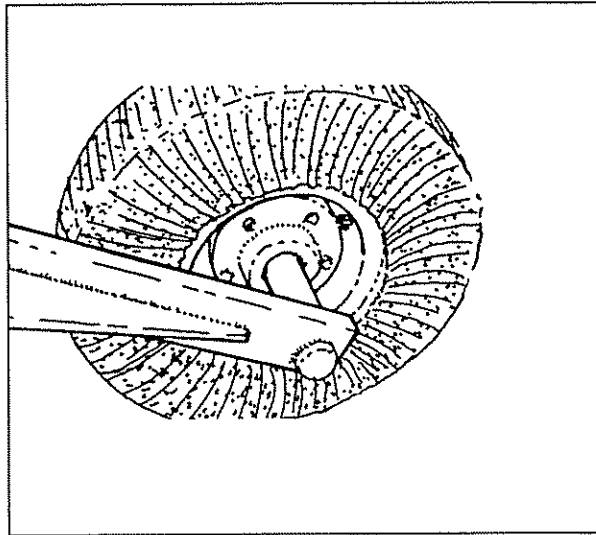

FIGURE 23

# ASSEMBLY

## F. WHEELS, TIRES AND HUBS

1. Attach laminated tires and wheels (See **Figure 24**) or 14" or 15" wheels and tires to hubs. (Tires are not furnished. Four-ply tires up to size 9.5L are acceptable.) Hub bolts must be tightened to 125 ft.lbs. minimum.



**FIGURE 24**

2. When attaching laminated tires and wheels, make certain the flat side of the nut is against the wheel. Note direction of travel and curvature of rubber segments in tire and install as shown in **Figure 25**.

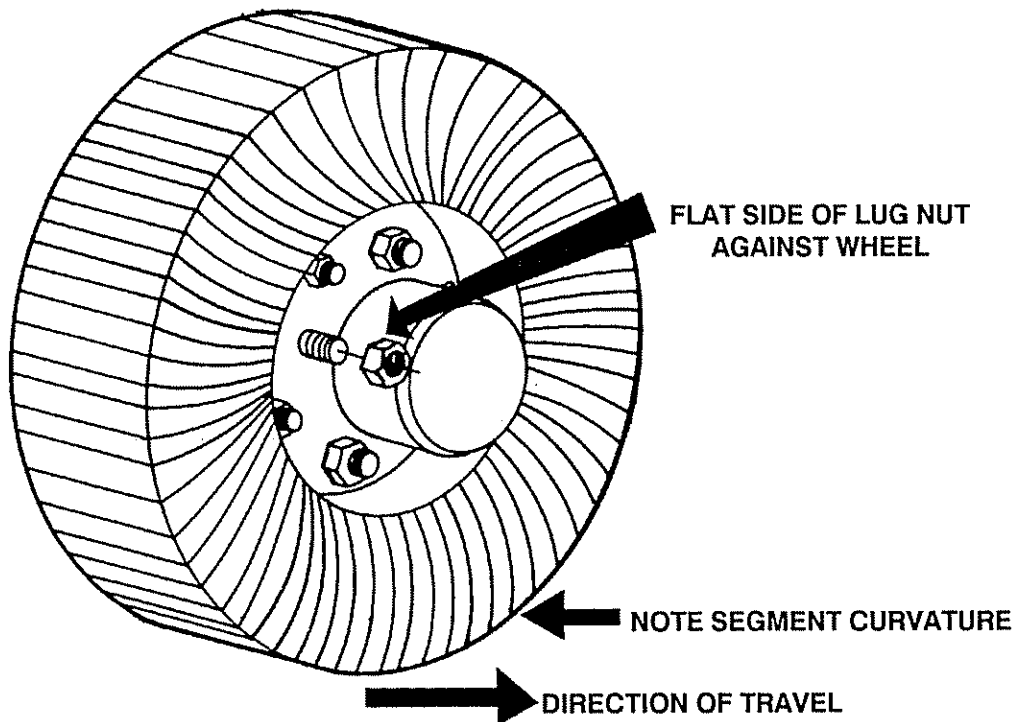

**FIGURE 25**

# ASSEMBLY

## TONGUE ATTACHMENT

1. Attach tongue to mower with (2) - 3/4" x 3" bolts, (2) - bushings, (2) - lockwashers, and (2) - nuts. See Figure 26.
2. Attach the leveling rods to the tongue with (2) - 3/4" x 2-3/4" bolts, (2) - bushings and (2) - nuts. See Figure 26.

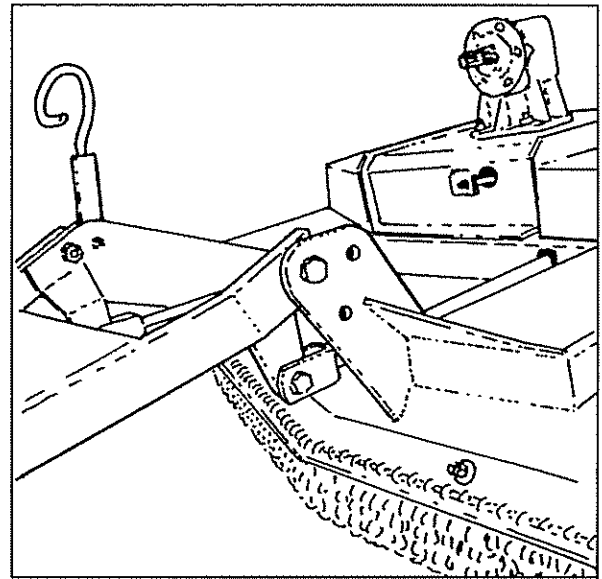
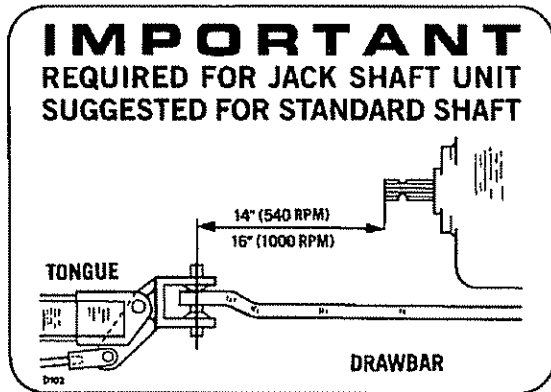

FIGURE 26

3. Attach hose bracket to the mower with (1) - 5/8" x 2" bolt, (1) - lockwasher and (1) - nut. See Figure 27.

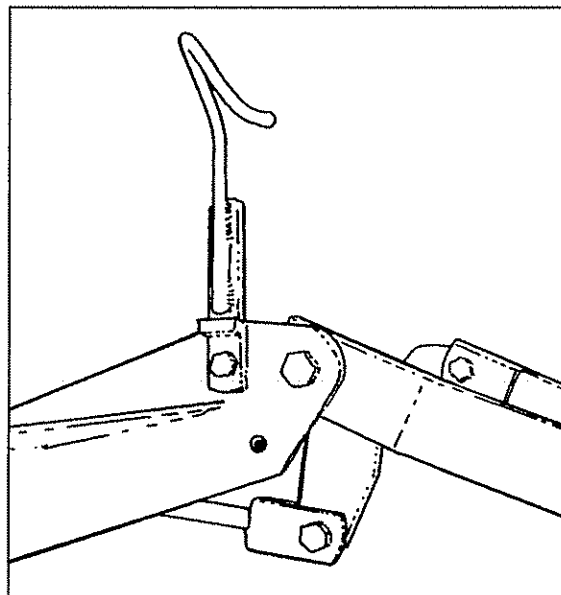

FIGURE 27



# ASSEMBLY

## MOWER PREPARATION

### 3-POINT HITCH

A tractor with a Category I or Category II hitch attaches to the top of the A-Frame without an adaptor. When attaching machine to a Category I hitch, the two lower hitch pins must be replaced with 7/8" diameter pins (turned inward) and a 1" o.d. bushing must be placed over the 3/4" Top Link Hitch Pin. Figure 28.

The tractor Lift Arms are attached to the Lift Lugs. Category I Hitches use 7/8" diameter Hitch Pins (turned inward) and 1-1/8" diameter Hitch Pins (turned outward) are required for Category II.

### 3-POINT LIFT WITH CHECK CHAINS (EXTRA EQUIPMENT)

No preparation is required for attaching check chains to a mower or a tractor. See page 11 for assembly.

### CAUTION



For increased safety during transport, check chains can also provide adequate transport height even without tractor hydraulics by lifting the mower and shortening the check chains as much as possible.

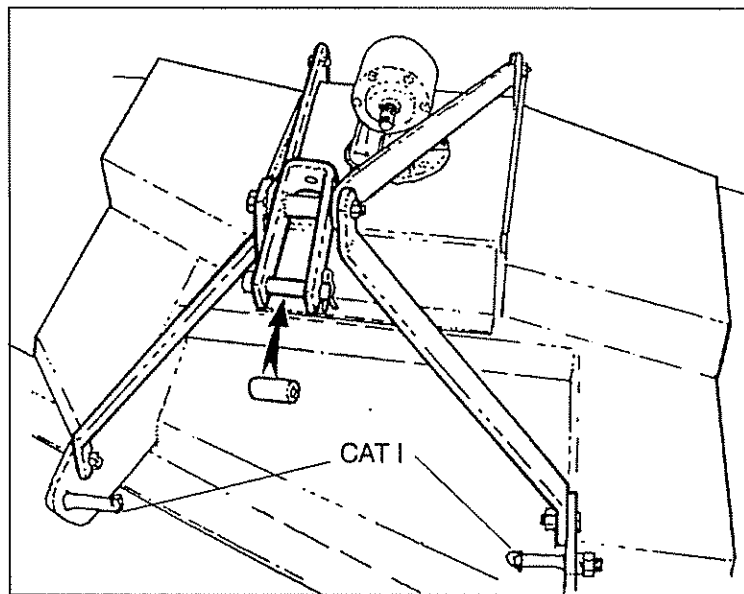

FIGURE 28

# OPERATION

## OPERATION

The safe operation of this machine is the responsibility of the operator. The operator should be familiar with the cutter and tractor and all safety practices before starting operation. This cutter is designed for use in light to medium brush shredding and pasture clipping. It is equipped with suction blades. recommended cutting speed for most conditions is from 2 to 5 mph. Always operate tractor PTO at 540 RPM.

**IMPORTANT:** Avoid damage to cutter, retighten all bolts after the first 10 hours of operation. Retighten blade carrier retaining nut on blade spindle shaft to 450 ft. lbs and hitch pins to 300 ft. lbs. after 25 and 50 hours operation.

## PREPARING THE TRACTOR

A few simple preparations will be necessary to prepare your tractor for use with the Rotary Cutter.

1. Equip tractor with lift link stabilizer bars, as described in the tractor operator's manual.

**IMPORTANT:** When using three-point mounted equipment, use front wheel weights, ballast in tires or a front tractor weight to improve front end stability. 20% of the combined tractor and cutter weight should be on the tractor front axle.

2. Remove cap from tractor PTO shaft.
3. Tractor PTO shield must be in place.

## ATTACHING CUTTER TO TRACTOR

**NOTE:** The cutter is equipped with Cat. II hitch pins. Bushings are required to mount on quick coupler hitches. These bushings are normally available from most dealers.

When attaching the Rotary Cutter to your tractor, follow the steps outlined in the tractor manual for attaching a 3-point hitch implement.

Attach cutter hitch pins to lower 3-point lift arms of tractor. Connect tractor top link to hole in top A-frame link on cutter using pin supplied.

With the Rotary Cutter attached to the tractor's 3-point hitch, proceed to connect the PTO as follows:

1. Grab and pull collar on end of attaching yoke toward cutter.
2. Slide yoke (with collar recessed) onto tractor PTO shaft.
3. Move yoke back and forth until locking collar "clicks" out, and locks the driveline in place.

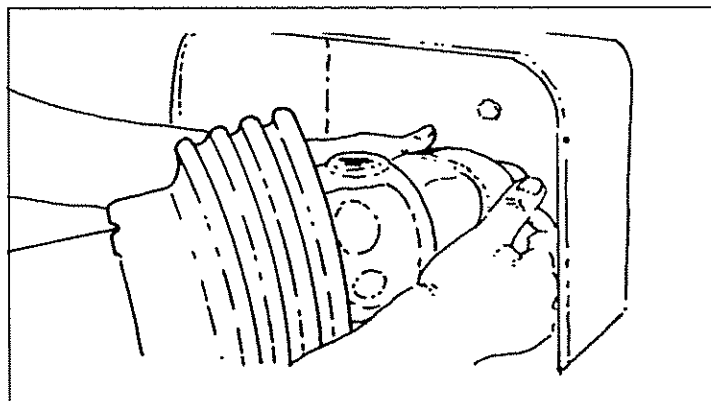

FIGURE 29

# OPERATION

## CHECK PTO LENGTH



**WARNING:** A loose shaft could slip off and result in personal injury or damage to cutter. When attaching PTO yoke to tractor PTO shaft, it is important that spring activated locking collar slides freely and locking balls are seated in groove on PTO shaft.



**WARNING:** Before operating cutter, check to make sure the driveline will not bottom out or become disengaged.

To adjust length, hold the half-shafts next to each other in the shortest working position. If end of driveline extends beyond shield cone, mark them according to figures below (40mm = 1-9/16"). Always maintain 1 9/16" clearance when operated in shortest working position. Shorten inner and outer guard tubes equally. Shorten inner and outer sliding profiles by the same amount that the shield tubes were shortened. Round off all sharp edges and remove burrs. Grease sliding profiles. **Figure 17.**

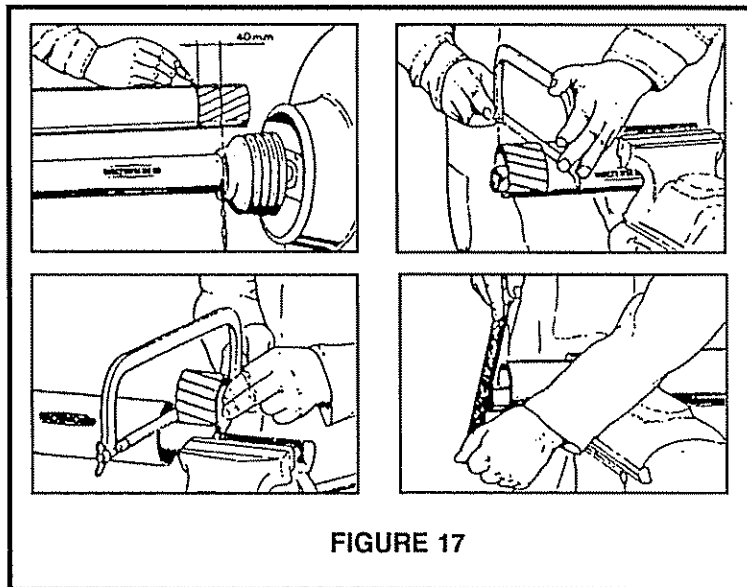

FIGURE 17



**WARNING:** Driveline profile engagement must always exceed 12" at any operating position.

# OPERATION

## CUTTING HEIGHT ADJUSTMENT



**WARNING:** Avoid personal injury. Be sure tractor engine is off and key is removed before making any adjustments.

**IMPORTANT:** Avoid very low cutting heights. Striking the ground with blades gives very severe shock loads to a mower and will cause damage to mower and drive.

To achieve maximum cutting efficiency, minimum power requirements, and provide the most uniform cut, the cutter should be operated with the rear of cutter slightly higher (1/2") than the front.

1. Place tractor and mower on level surface.
2. Raise the mower to approximate desired cutting height with tractor hydraulic lift control lever.
3. Loosen clamp bolt on gauge wheel frame tube. Slide clevis clamp on tube until gauge wheel hits ground. To raise cutter, slide clevis clamp forward and to lower cutter, slide clamp to rear. Retighten clamp bolt.

**NOTE:** Install *OPTIONAL* check chains when there is a problem with tractor hydraulic system or when a constant preadjusted cut height is required. See check chain accessory.

4. Lower the mower slowly until cutter is 1/2" higher at rear than at front. Position the adjustable stop on the tractor lift quadrant against the lift control lever so the cutter can be returned to the same cutting height.
5. Adjust the length of the top link so that when lifting the cutter the front of the cutter will raise 2 to 2-1/2 inches before the gauge wheels leave the ground. (This will allow the flexible hitch to pivot and allow the cutter to follow the contour on uneven ground.)
6. Level the mower side to side with the tractor lower link adjustment.

**IMPORTANT:** When raising cutter to transport height, be sure there is clearance between the cutter and driveline. Damage will result if driveline hits cutter deck.

## SLIP CLUTCH ADJUSTMENT

The Mower has a two-plate clutch. The torque setting in this clutch is set at factory and cannot be changed.

**IMPORTANT:** Spring disassembly nuts on clutch must be loose at end of threaded stud for clutch to function properly.

Avoid overheating of clutches caused by too long or too frequent operation of the clutch since this can damage the friction plates and clutch parts.

## STARTING & STOPPING CUTTER

Power for operating mower is supplied from tractor PTO. Refer to your tractor manual instructions for engaging and disengaging the PTO. Always engage the PTO at low engine rpm. Always operate at 540 rpm. Learn how to stop tractomowd cutter quickly in case of an emergency.

**IMPORTANT:** Stop mower and tractor immediately upon striking an obstruction. Inspect the mower and repair any damage before resuming operation.



**WARNING:** Avoid personal injury. When attempting to stop a tractor which does not have live PTO, the momentum created by the blade carrier of a rotary mower can cause the tractor to be pushed forward.

# OPERATION

The installation of an overrunning clutch is recommended if the operating tractor does not have live power take-off. See your dealer for additional information.

To commence operation, reduce engine speed and engage the tractor PTO lever in engine PTO position. Before starting to cut, gradually increase engine speed to develop 540 rpm at the PTO.



**DANGER:** Install chain guards if operating with people or livestock in the area or close to highways or buildings. Stop mowing if bystanders come within 100 yards.



**WARNING:** Do not attempt to operate the Rotary Cutter in GROUND SPEED PTO.

Enter the area to cut with the mower operating at 540 rpm and, if it becomes necessary to regulate engine speed temporarily during operations, increase or decrease the throttle setting gradually--never exceed 540 rpm for extended periods.

To transport, disengage the PTO and raise the machine as high as possible without allowing driveline to strike front of mower deck.

## CUTTING SPEED

Proper ground speed for cutting will depend upon the height, type, and density of material to be cut.

Normally, ground speed will range from 2 to 5 mph. Tall, dense material should be cut at low speed, while thin, medium-height material can be cut at a faster ground speed.

## CUTTING TIPS

Always operate PTO at 540 rpm when cutting. This is necessary to maintain proper blade speed and to produce a clean cut.

Under certain conditions, tractor tires may roll some grasses down and prevent them from being cut at the same height as the surrounding area. When this occurs, reduce the tractor ground speed, but maintain 540 PTO rpm. The lower speed will permit grasses to atleast partially rebound and be cut. Taking a partial cut and/or reversing the direction of travel may also produce a cleaner cut.



**WARNING:** Avoid personal injury. Pick up all rocks and other debris before cutting. Enter new areas carefully. Cut material higher the first time to allow cutter to clear unseen objects. Never assume an area is clear. Always check.

Extremely tall grass should be cut twice. Raise cutter and cut half the desired height. Cut the second time at desired height at 90 degrees to first pass.

Remember, sharp blades produce cleaner cuts and use less power.

Before cutting, analyze the area to determine the best cutting procedure. Consider the height and type of material and the terrain type: hilly, level or rough.

# OPERATION

## UNEVEN TERRAIN



**WARNING:** Avoid tractor rollovers, be careful when operating tractor and cutter on uneven ground. Equip your tractor with a roll-over protective structure (ROPS) and seat belts. Always have seat belts snugly fastened.

In extremely uneven terrain, rear wheel weights, front tractor weight and/or front tire baalast should be used to improve stability. Pass diagonally through sharp dips and avoid sharp drops to prevent “hanging up” the tractor and cutter.

Avoid sudden starts and stops while traveling up or down hill.

Always cut down slopes. Never across the face. Avoid operation on steep slopes. Slow down on sharp turns and slopes to prevent tipping or loss of control.

## BLADE CARRIERS

Always disconnect the Driveline from the tractor and block mower up securely before working on the Blades or Blade Carriers.

Inspect the Blade Carriers frequently. After first operation, check the Blade Carrier Hubs for tightness on the Spindle Output Splined Shaft. Keep all Blade Bolts tightened to 250 ft.lbs. (left hand threads) and, for better mowing, keep all Blades sharp. Always use Alamo Group Blades. For servicing of the Blades, the manufacturer has provided an Access Hole (**Figure 18**) to side of the Gearbox. Check the Blade Bolts frequently for excessive wear, and replace if necessary. When replacing Blades, check the cutting edges in relation to the Blade Carrier Rotation. For removing the Blade Carrier Hub from the Spindle, use a Drift Punch thru the assess hole or Gear Puller. Do not hammer on the end of the Output Shaft, since this may damage the Bearings.

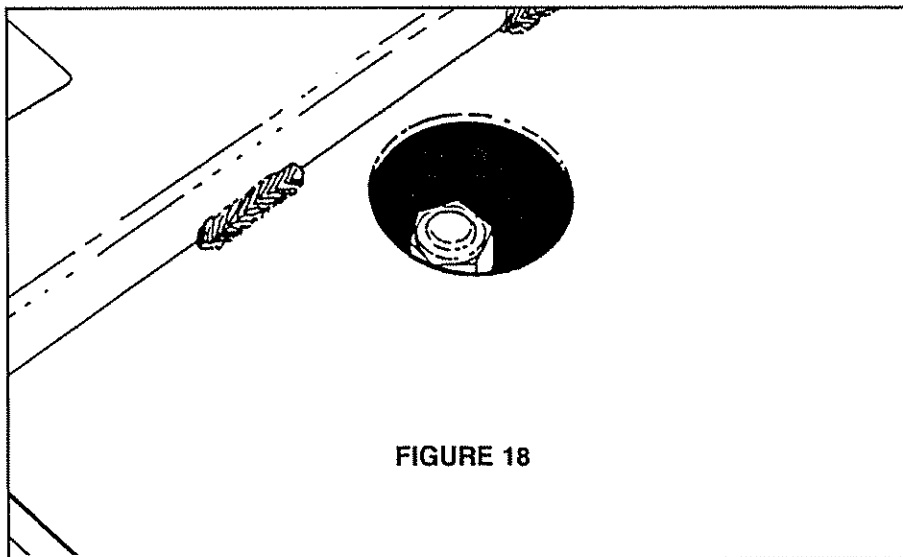

# OPERATION

## TRANSPORTING

Pay particularly close attention to the Safety Messages regarding Mower transport. Avoid unnecessary injuries and equipment damage by exercising cautious, conscientious travel procedures.

Attaching the Mower to the Tractor increases the overall length of the working unit. Allow additional clearance for the Mower to swing when turning.

Raise the Mower as high as possible for transporting while maintaining clearance between the Driveline and Deck of the 3-Point Lift Mower.

Pneumatic tire pressure should be kept at around 20 psi to decrease shock during transport. When using puncture-proof, Laminated Tires, be sure that the flat side of the Lug Nut is against the wheel and reduce travel speed to 15 MPH max.

When using Check Chains, adjust as described earlier for safer transport.

### WARNING



When transporting the Mower on a road or highway, use the tractor warning lights, SMV Sign, Reflectors, and other devices for adequate warning to the operators of other vehicles. Check the traffic regulations governing the locale where mowing is to be done, and work safely within those guidelines.

### CAUTION



Be sure that the tractor Lift Lever is locked into the "transport" detent before attempting to transport the Mower.

### CAUTION



Hold transport speed to 15 MPH especially when using Laminated Tires. These tires are designed for off-road use only. They can be used on road surfaces at very low speeds and then only for a short distance. Heat from pavement friction can build up and cause the tires to ignite. The steel band holding the sections in place could break and cause extensive damage to the Mower and tractor as well as possible injury to the operator and passersby.

## BEFORE OPERATING OR TRANSPORTING THIS MOWER:

Always display this emblem on the rear of the tractor transporting this mower where it is clearly visible to oncoming traffic. Prominent display of this symbol will help the operator avoid accidents which could cause injury or possibly death.

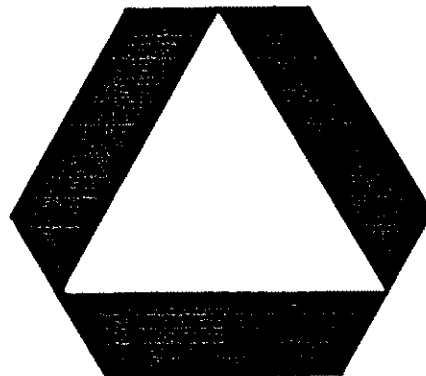

SMV SYMBOL

# OPERATION

## TROUBLESHOOTING

PROBLEM	POSSIBLE CAUSE	REMEDY
NOT CUTTING CLEAN	<p>Blades dull. Blade rotation incorrect. Carrier RPM too low. Mower not leveled.</p> <p>Ground speed too fast. Blades locked back. Blades bent up.</p>	<p>Sharpen or replace Blades. Use correct Blade for Carrier. Increase PTO speed to 540. Adjust machine level (in heavy weeds, 1/2" to 1" low in front). Reduce ground speed. Free Blades. Replace Blades.</p>
BREAKING BLADE BOLTS	<p>Operating with loose Blade Bolts. Worn Blade Bolt.</p>	<p>Tighten Blade Bolts to 250 ft./lbs. Replace Bolt.</p>
CUTTING TOO HIGH	<p>Blades bent up. Blade Carrier bent. Blades on upside down.</p>	<p>Replace Blades. Straighten or replace Blade Carrier. Turn Blades right side up and tighten.</p>
MOWER VIBRATES	<p>Blade locked back. Drivelines not phased. Blade broken. Blade Carrier bent. Blade Hub not properly seated on Shaft.</p> <p>New Blade matched with worn Blade.</p>	<p>Loosen locked Blade. Replace Driveline. Replace Blades in sets. Repair or replace Carrier. Remove Hub, check Hub and Shaft, and replace or seat properly.</p> <p>Replace Blades in sets.</p>
MOWER WINDROWING	<p>Cutting heavy material.</p>	<p>Raise Mower and reduce ground speed.</p>
BLADES WEAR FAST	<p>Cutting in sandy or rocky conditions. Blades too soft.</p>	<p>Increase cutting height.</p> <p>Replace Blades with hardened, high-quality, alloy Alamo Blades.</p>
BLADE BOLTS WORKING LOOSE	<p>Bolts not tightened. Bolt hole elongated or oversized. Locknut worn out.</p>	<p>Tighten Bolts to 250 ft. lbs. Replace Bushing or replace Blade Carrier. Replace Locknut.</p>
MOWER STREAKS BEHIND RIGHT TRACTOR TIRE	<p>Carrier RPM too low. Ground speed too fast Tire mashes grass down.</p>	<p>Increase PTO speed to 540. Reduce ground speed. Move tire out as much as possible to allow blade to pick up grass. Tire must be outside of spindle housing to do best job of cutting.</p>



# OPERATION

## TROUBLESHOOTING (Continued)

PROBLEM	POSSIBLE CAUSE	REMEDY
BROKEN CROSS OR CUPS	Load too high for joint. Check joint angles and phasing.	Adjust slip clutch. Slow down or raise Mower.
END GALLING OF CROSS AND CUPS	Speed too high. Ears have deformed.	Reduce speed to 540. Install thrust washer.
NEEDLE ROLLERS HAVE BRINELLED INTO CUP AND CROSS	Load too high for joint.	Check for small joint angles. Adjust slip clutch. Check joint angles and phasing.
SHAFT OR TUBE TWISTED	Over-loaded.	Replace part and then slow down or raise Mower. Adjust slip clutch.
TUBE BROKEN IN WELDED SEAM	Over-loaded.	Replace part.
YOKE BROKEN AT EAR TIP	Over-loaded.	Replace part.
GEARBOX NOISY	Improper backlash. Rough gears. Worn Bearing.	Set backlash to .010 loose. Run in or change Gears. Replace Bearing.
SLIP CLUTCH SLIPPING EXCESSIVELY	Excessive load.  Springs weak. Improper adjustment. Too much power for Slip Clutch. Friction Facings worn. Oil on Facings. Friction Facings glazed.	Reduce ground speed and/or raise Mower. Replace Springs. Re-adjust Slip Clutch. Reduce ground speed and material intake. Replace Facings. Replace Facings. Clean with emery cloth.

# OPERATION

## TROUBLESHOOTING (Continued)

PROBLEM	PROBABLE CAUSE	REMEDY
GEARBOX LEAKING	Damaged Oil Seal. No Oil Seal Oil too light. Bent Shaft. Oil Seal race rough. Oil Seal installed wrong. Oil Seal not sealing in the housing. Bearings loose. Oil level too high. Gasket damaged. Bolts loose.	Replace Seal. Install Oil Seal. Use 000 EP grease. Replace Oil Seal and Shaft. Replace Shaft or repair Race. Replace Seal. Replace Seal or use a sealant on O.D. of seal. Adjust Bearings. Drain oil to proper level. Replace Gasket. Tighten Bolts.
DRIVELINE INTEGRAL SHIELDS RATTLING OR NOT TURNING FREELY	Integral Shields bent.  Nylon Bearing worn.	Replace Shield.  Replace Nylon Bearing.

02925100



### CAUTION



FOR YOUR SAFETY AND TO GUARANTEE OPTIMUM PRODUCT RELIABILITY, ALWAYS USE GENUINE ALAMO GROUP REPLACEMENT PARTS. THE USE OF INFERIOR REPLACEMENT PARTS MAY CAUSE PREMATURE OR CATASTROPHIC FAILURE WHICH COULD RESULT IN SERIOUS INJURY OR DEATH. IF YOU HAVE ANY QUESTIONS CONCERNING THE REPAIR PARTS YOU ARE USING, CONTACT ALAMO GROUP, P.O. BOX 549, SEGUIN, TX. 78156.

# MAINTENANCE

## MAINTENANCE INSTRUCTIONS

Before operating your Rotary Mower, make sure it is properly lubricated and thoroughly inspected. Only a minimum of time and effort is required to regularly lubricate and maintain this machine to provide long life and trouble free operation.



**WARNING:** Always disengage the PTO before raising the Rotary Mower for transporting or making adjustments to prevent injury from rotating driveline or blades.

## LUBRICATION INFORMATION

Do not let excess grease collect on or around parts, particularly when operating in sandy areas. The accompanying illustration shows lubrication points. The chart gives the frequency of lubrication in hours based on normal operating conditions. Severe or unusual conditions may require more frequent lubrication. Lubricate the spindles until grease is forced out of the breather hole.

Use a lithium base NLGI grade 2 EP grease for all locations shown. Be sure to clean the fitting thoroughly before using grease gun. Daily lubrication of the PTO slip joint is necessary. Failure to maintain proper lubrication will result in damage to U-joints, gear box and/or drive line.

**NOTE:** The telescoping PTO shaft inside the shielding must be lubricated daily. Disconnect PTO shaft from tractor and extend or compress length to align holes in both shield halves. The grease fitting can then be exposed by rotating both shields (with holes aligned) until fitting appears in sleeve. **NOTE:** If no holes in shield tubes, pull driveline halves apart so grease can be applied into cavity of outer tube of driveline half. Insert grease gun and grease thoroughly.

**WARNING:** Keep fingers out of slot in shield to prevent injury.

Reconnect PTO shaft to tractor. Raise and lower mower after applying grease to spread over joint working area.

**WARNING:** When attaching PTO yoke to tractor PTO shaft, it is important that spring-activated locking collar slides freely and locking balls are seated in groove on PTO shaft. A loose shaft could slip off and result in personal injury or damage to cutter.

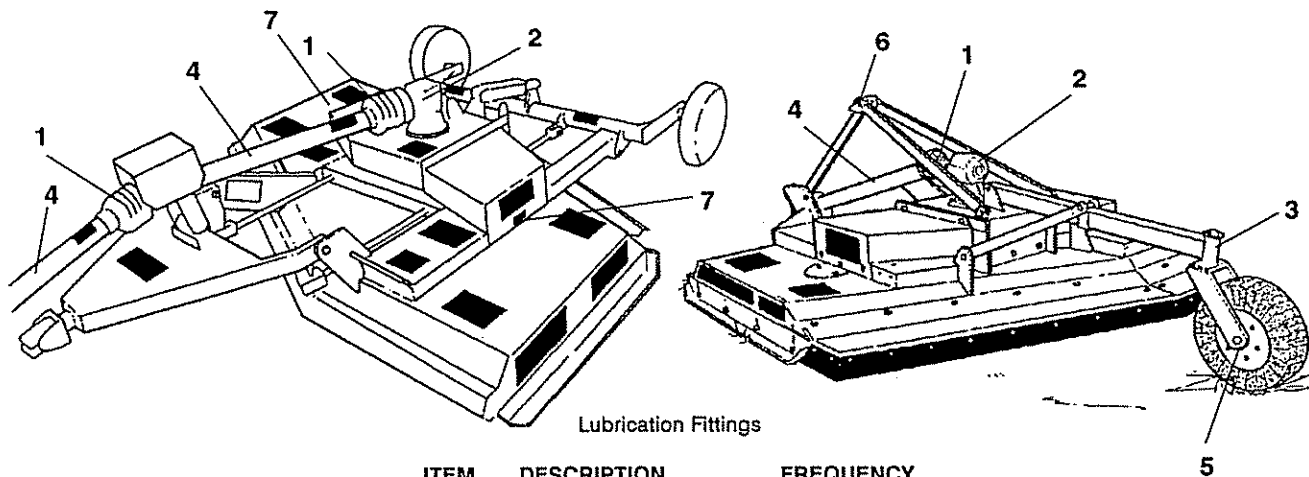

ITEM	DESCRIPTION	FREQUENCY
1	U-Joints	8 hour
2	Gearbox-1/2 full	Check Daily
3	Tail Wheel Pivot Arm	8 hours
4	Driveline slip sleeve	8 hours
5	Tail Wheel Hub	8 hours
6	Pivot Points (SAE 30 WT).	8 hours
7	Spindle	8 hours

# MAINTENANCE

## GEARBOX

The gearbox should be full (18 ounces .54 liters) and not require additional lubricant unless the box is cracked or a seal is leaking. It is recommended that the 1/8" oil level plug (**Figure 19**) be removed after every 10 hours of operation. If required, oil should be added until it runs out hole.

Recommended lubricants are Sunoco 850 AEP, GULF Mining Lube HD, Mobile EP023 or NLGI Grade 000EP Grease.

*NOTE: Make sure mower is level when checking oil in the gearbox.*

*NOTE: Overfilling of Gearbox will cause pressure to build up and cause Grease Seals to leak.*

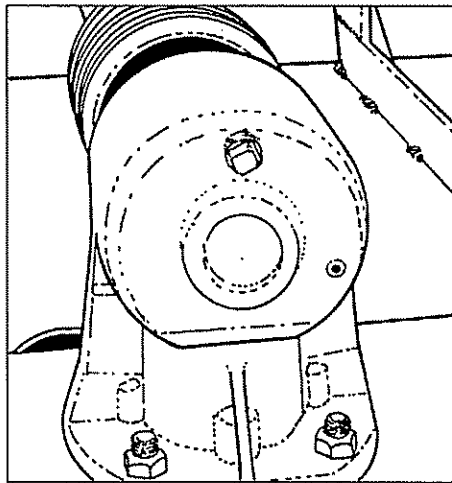

FIGURE 19

## TAIL WHEEL

Tail Wheel Bearings are packed at the factory with heavy-duty #2 bearing grease. Grease Fittings are provided in the Wheel Hub (**Figure 20**) and Tail Wheel Beam (**Figure 20**). Grease every 10 hours of use.

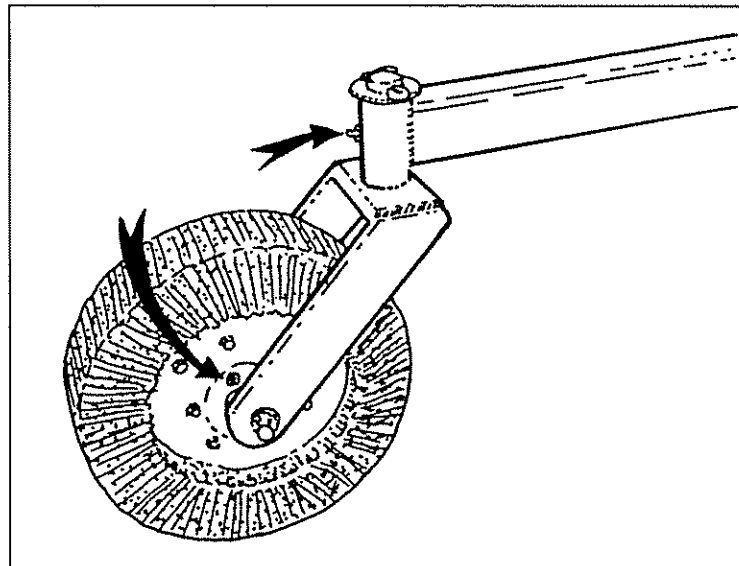

FIGURE 20

# MAINTENANCE

## UNIVERSAL JOINTS

Grease Fittings are located on the Cross of each U-Joint. Grease after every 10 hours use.

## DRIVELINE

The telescoping PTO shaft inside the shielding must be lubricated daily.

Disconnect driveline from tractor and pull halves apart. Insert grease into outer profile cavity on half attached to gearbox and spread evenly. Install driveline halves together.

Reconnect driveline to tractor. Raise and lower mower after applying grease to spread over joint working area.



**WARNING:** When attaching PTO yoke to tractor PTO shaft, it is important that spring-activated locking collar slides freely and locking balls are seated in groove on PTO shaft. A loose shaft could slip off and result in personal injury or damage to cutter.

## BLADE SERVICING

Inspect blades before each use to determine that they are properly installed and in good condition. Replace any blade that is bent, excessively nicked, worn, or has any other damage. Small nicks can be ground out when sharpening.

**IMPORTANT:** When sharpening blades, grind each blade the same amount to maintain balance. The difference in blade weights should not exceed 1 ounce. Unbalanced blades will cause excessive vibration which can damage gear box bearings. Vibration may also cause structural cracks in cutter housing.



**WARNING:** Use only original equipment blades on this cutter. They are made of special heat-treated alloy steel. Substitute blades may not meet specifications and may fail in a hazardous manner that could cause injury.

## BLADE SHARPENING

Always sharpen both blades at same time to maintain balance. Follow original sharpening pattern as shown in **Figure 21**. Always sharpen blades by grinding. **DO NOT** heat and pound out edge. Do not sharpen blade to a razor edge, but leave a 1/16" blunt edge. Do not sharpen back side of blade.



**WARNING:** Avoid personal injury. Always block the mower up to prevent it from falling when the blades and/or carrier are being serviced.

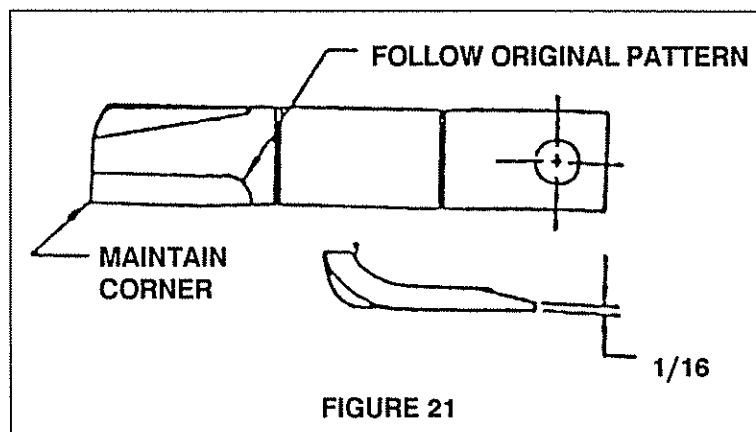

# MAINTENANCE

## BLADE REMOVAL

To remove blades for sharpening or replacement, remove the cover plate on deck of mower near gearbox. Remove locknut from blade bolt. **NOTE:** Inspect locknut after removal and replace if threads are damaged. Always replace nut when replacing blade bolt. When installing blades, be sure and check bushings pivot diameter for wear. Replace bolt if worn more than 1/4 inch at any point. Install blade bolts with partially worn side of bolt either toward or away from center. Tighten lock nut to 300 ft. lbs.



**WARNING:** Avoid personal injury. Blade and/or blade carrier removal should be done only with the tractor engine shut off, key removed, in neutral, parking brake on, and PTO disengaged and the cutter blocked in the raised position.



**WARNING:** Avoid personal injury. Do not work under mower without support blocks to keep frame from falling.

## BLADE CARRIER REMOVAL

Remove cotter pin and loosen slotted nut on gear box shaft. Loosen but do not remove the nut until the blade carrier is loosened. Use a suitable 2 jaw gear puller to pull carrier off tapered spindle shaft. Once blade carrier is loose on shaft, remove nut and washer and remove carrier.

## BLADE CARRIER INSTALLATION

Clean the splines on both the blade carrier and output shaft. Position carrier on the spindle output shaft and install flat washer and 1" hex nut.

Tighten nut holding blade carrier to minimum 450 ft. pounds, strike the carrier near the hub several times with a heavy hammer to seat the hub. Use a suitable spacer over the nut to prevent damage to the nut and threads. Retighten the nut to 450 ft. pounds. Install cotter pin and spread.

**IMPORTANT:** Always recheck gearbox output shaft slotted blade carrier retaining nut torque after a few hours operation.

## SLIP CLUTCH

A slip clutch is incorporated in the PTO driveline. It is designed to slip, absorb the shock load, and protect the driveline.

Clutch torque setting is factory-set and cannot be changed. If clutch slips excessively, check friction discs for excessive wear. Discs are 1/8" thick when new. Replace after 1/32" wear. See Clutch Service Instructions on Page 31.

# MAINTENANCE

## SEASONAL CLUTCH MAINTENANCE

It is important the clutches slip when an obstacle or load heavier than clutch setting is encountered. Before using the mower each season, use the following procedure to make sure the clutch will slip and give the overload protection required.

1. Tighten four nuts on back side of clutch until they contact spring plate and then turn approximately three turns. This will release most of spring pressure off clutch discs. For more information see Clutch Service Instructions.
2. Attach machine to tractor, set engine at approximately half throttle and quickly engage PTO. This procedure will break clutch facings loose and allow the proper torque to be maintained.
3. Return four nuts to original position at end of threaded studs.

**NOTE:** *If machine sits outside longer than 30 days and is exposed to rain and humid air, the clutches should be removed from machine and stored in dry area. Clutch facings will soak up moisture, causing the metal plates to rust badly. When this occurs, the break-away torque increases greatly and damage to gearbox, driveline, or tractor PTO can occur.*

## STORAGE

Your rotary mower represents an investment from which you should get the greatest possible benefit. Therefore, when the season is over, the mower should be thoroughly checked and prepared for storage so that a minimum amount of work will be required to put it back into operation for the next season. The following are suggested storage procedures:

1. Thoroughly clean the mower.
2. Lubricate the mower as covered in Maintenance Section.
3. Tighten all bolts and pins to the recommended torque.
4. Check the mower for worn or damaged parts. Make replacements immediately.
5. Store the mower in a clean, dry place with the mower housing resting on blocks.
6. Use spray touch-up enamel where necessary to prevent rust and maintain the appearance of the mower.

MAKE EVERY DAY  
A HOLIDAY  
FROM ACCIDENTS

# MAINTENANCE

## GEARBOX SERVICE INSTRUCTIONS GEARBOX DISASSEMBLY (FIGURE 22)

1. Remove 6 capscrews (Ref. #16) from input shaft bearing housing (Ref. #13).
2. Tap around circumference of bearing housing (Ref. #13) to loosen housing and shims. Then (Ref. #9) pull complete shaft and housing assembly (See Fig. 8) out of main housing.
3. Remove 4 capscrews (Ref #21), break gasket loose, and then remove the bearing retainer cap (Ref. #2).
4. Output shaft assembly must be removed from main housing by driving or pulling shaft out bottom end. NOTE: Once lower bearing is out of housing, the complete assembly will drop down until top bearing engages lower bearing bore. To complete removal of output shaft assembly, it is necessary to keep shaft aligned on center line of housing when removing top bearing out bottom end. Normally the simplest method of removing the output shaft assembly is to attach a slide hammer puller to the shaft and use that to pull the shaft out.

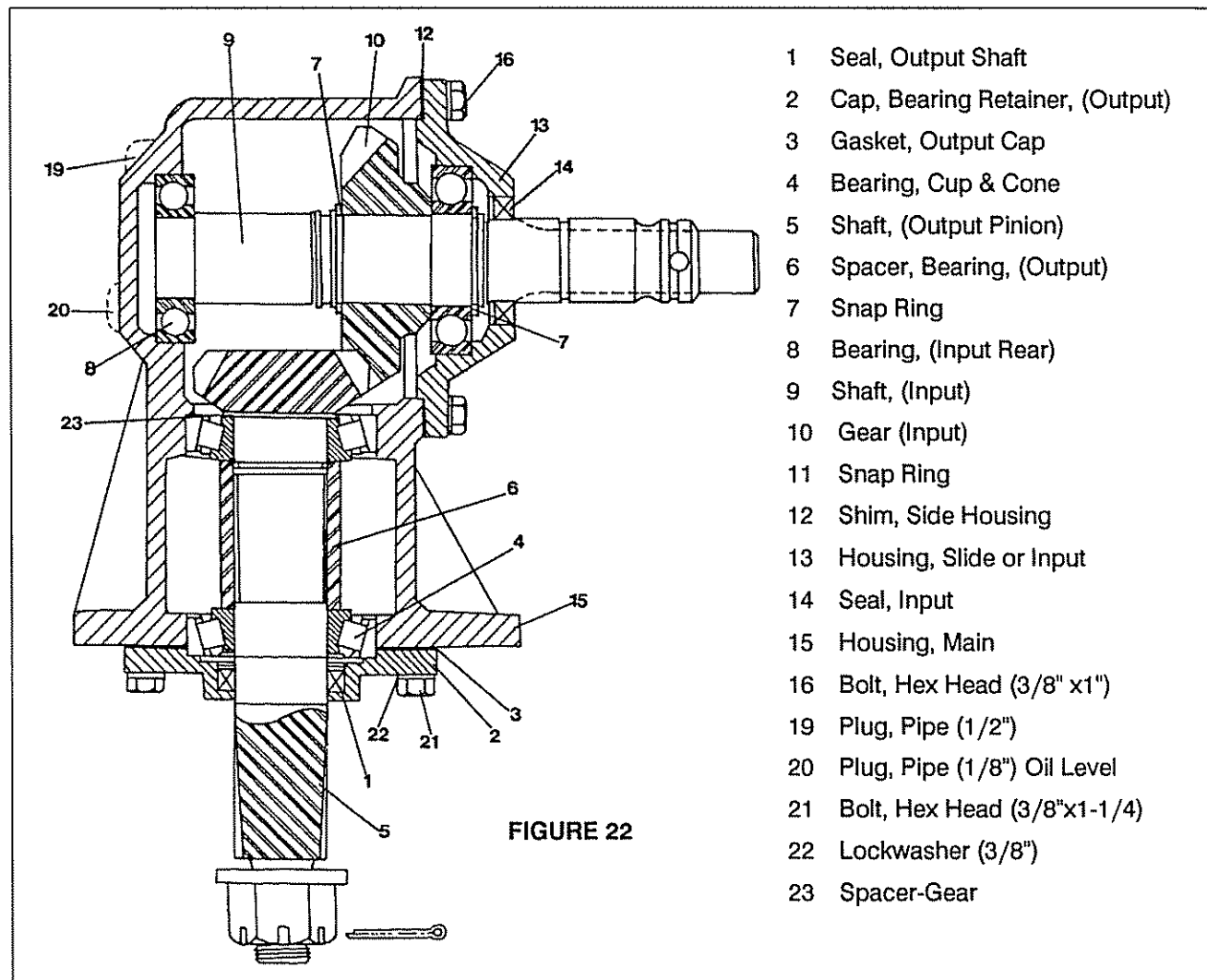

5. The Gearbox is now disassembled into four (4) sub-assemblies:
  1. Input shaft assembly Fig. 23
  2. Output shaft assembly Fig. 24
  3. Lower bearing retainer assembly Fig. 25
  4. Main housing assembly



# MAINTENANCE

## INPUT SHAFT (FIGURE 23)

### DISASSEMBLY AND ASSEMBLY

1. Remove snap ring (Ref #11) and then remove bearing housing (Ref. #13) and then remove bearing housing (Ref. #13) by holding end of shaft which does not have a cross hole or splines and tap opposite end of shaft on solid surface. Shock force will remove housing from bearing (Ref. #4).
2. Remove snap ring (Ref. #7) closest to bearing. Tap end of shaft as explained in Step 1 until bearing and gear drop off shaft.
3. Worn components can now be replaced and assembled in reverse order.

### ASSEMBLY ORDER

1A. Install gear onto shaft as shown in Fig. 8. Note locations of two snap ring grooves.

2A. Install bearing on shaft.

NOTE: Use tube with ID. just large enough to go over shaft to drive bearing against gear. Install snap ring (Ref 7).

3A Press oil seal flush with front side of bearing housing (See SEAL INSTALLATION RECOMMENDATIONS).

4A Lubricate ID. of seal and insert shaft until bearing contacts housing. Press bearing into housing by hitting end of shaft. Once bearing is in place insert snap ring (Ref #11). NOTE: Snap ring must be inserted between bearing and gear before pressing bearing into housing.

### SEAL INSTALLATION RECOMMENDATIONS

1. Check Seal - for damage that may have occurred prior to installation. A sealing lip that is turned back, cut or otherwise damaged should be replaced.
2. Check Bore - to see that leading edge is debarred. A rounded corner or chamfer should be provided.
3. Check Shaft - remove surface nicks, burrs and grooves and lubricate with a hard, fibrous grease. NOTE: Wrap plastic tape around irregular shaft surfaces such as splines to protect seal during assembly.
4. Use Correct Installation Tool - Always use pipe or tube with approximate same OD. as seal and press seal by striking tube.

NEVER HAMMER DIRECTLY ON THE SURFACE OF THE SEAL.

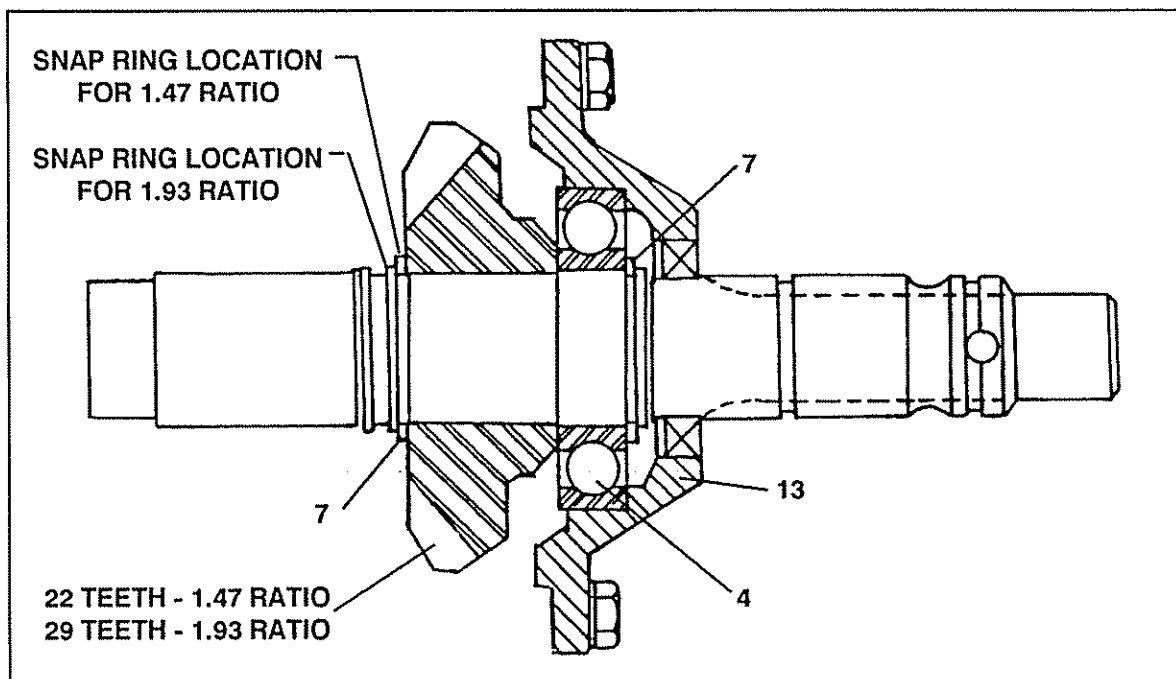

FIGURE 23

# MAINTENANCE

## DISASSEMBLY OUTPUT SHAFT (FIGURE 24)

1. Install slotted nut (Ref 18, Fig 7) onto shaft and then tap shaft end on solid surface to remove lower bearing spacer, upper bearing, and gear spacer.

## ASSEMBLY

1A. Assembly of output shaft is accomplished in exact reverse order. Install bearing assembly over shaft and press up against bottom end of gear. NOTE: Be sure and install thin spacer between gear and bearing assembly.

2A. Install spacer and lower bearing on shaft.

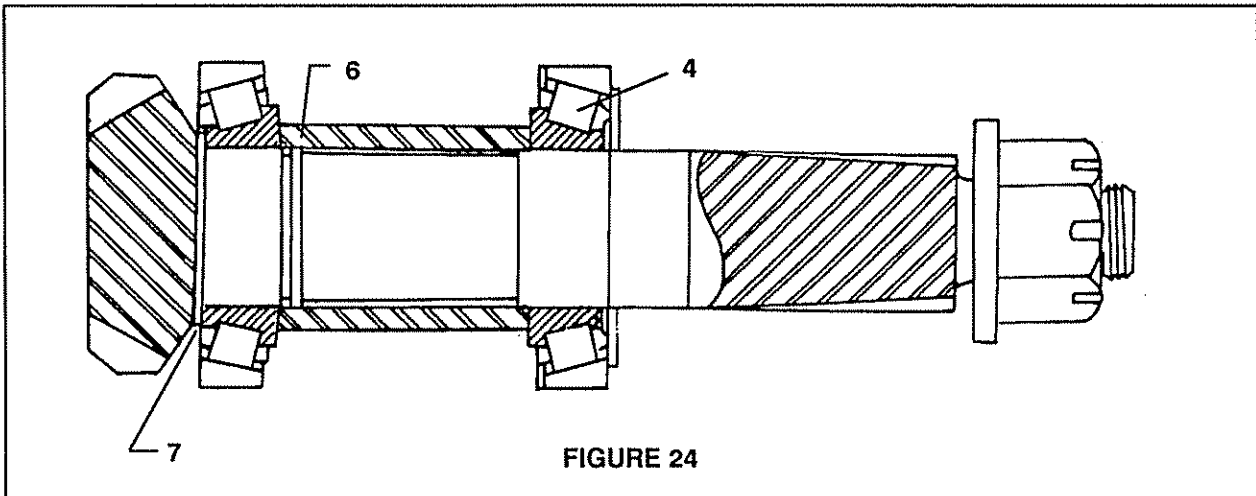

## LOWER BEARING RETAINER CAP (FIGURE 25)

1. Remove old seal from cap and press in new seal. (See SEAL INSTALLATION RECOMMENDATIONS.)

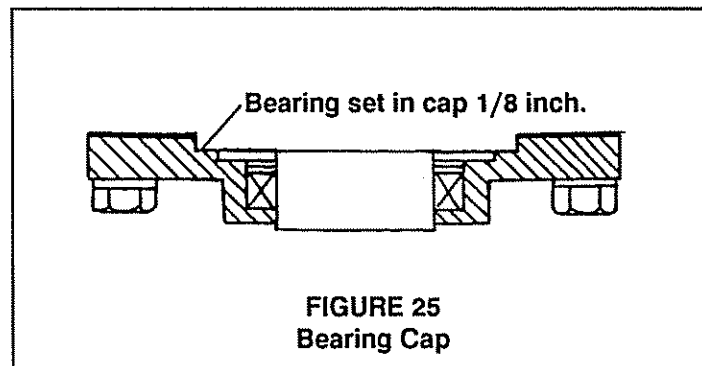

# MAINTENANCE

## MAIN GEAR BOX

1. Remove bearing (Ref #8 **FIGURE 22**) from inside main housing. A special slide hammer puller (PROTO No. 4056) or equal may be required to remove bearing. Press in new bearing using driving tube or pipe with approximate same OD as bearing. Seat outer race of bearing against shoulder in housing.

## GEAR BOX ASSEMBLY STEPS

Clean and scrape all gaskets surfaces.

A.

1. Insert output shaft assembly into main housing and press into place. NOTE: Use pipe or tube with approximate same OD. as bearing and press into place by striking or pressing on tube.

2. Prelube lower bearing.

3. Place lower gasket in place and then carefully slide bearing retainer cap assembly down shaft.

4. Install bolts and lockwashers and torque to 40-50 ft. lbs.

B.

1. Assemble three shims onto input shaft housing. Insert input shaft assembly into main housing, installing shaft end into bearing in main housing. It may be necessary to rotate shaft to align gear teeth so that housing will install completely.

2. Gear backlash check procedure see Figure 26. Set dial indicator at marked point at bottom of spline, then while holding bottom shaft so it will not rotate; rotate the input shaft back and forth noting extreme indicator readings. If total indicator deflection reading does not fall between .002 to .006, then shims will have to be added to increase backlash or deleted to decrease backlash.

3. Remove 1/2" pipe plug (#12) and fill gearbox with proper lubricant. See Maintenance Section in Operator's Manual for proper specification.

4. Install pipe plug and gearbox assembly is complete.

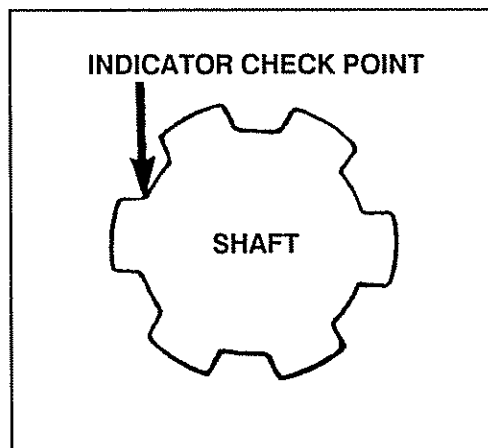

**FIGURE 26**

# MAINTENANCE

## FRICITION CLUTCH SERVICE INSTRUCTIONS DISASSEMBLY (SEE FIGURE 27)

1. Remove snap ring (#17). This allows removal of complete quick coupler (#13, 14, 15, 16) and three clutch lock balls (#18).
2. Tighten four hex nuts (#10) until spring assembly (#9 & #12) are loose in main housing (#3).  
NOTE: Small amount of lubricant on nut and threaded stud will avoid problem of twisting studs off.
3. Place clutch in vice so it can be held firm during next step.
4. Slots have been punched in outer circumference of main housing and at four equally spaced points around housing it has been deformed inward over the belleville springs. This retains the springs in housing when four hex nuts are released. These four deformed areas must be straightened out so that pressure plate assembly can be removed from housing. A special clutch service tool part number BMB 8522 can be purchased and used to straighten deformed areas during disassembly and reform them during assembly. This tool is a bar with two pins located at one end (See Fig. 11). To straighten housing place end pin on inside of clutch housing and second pin on outside of clutch housing. Apply pressure on end of bar so that pin in end bar will straighten housing.

**IMPORTANT:** Hex nuts (#10) must be tightened to release spring pressure before attempting to straighten main housing. Clutch can now be disassembled.

5. Remove spring pressure plate assembly from clutch housing. Remove all other parts from clutch housing noting order in which they are removed.
6. Inspect all surfaces where clutch linings (#4) contact and clean and remove any scale or burned deposits. If necessary use fine emery cloth to clean plate surfaces.
7. Assemble clutch parts as shown in Figure 11. Deform housing at four places around circumference using special tool or a dull chisel. Using special tool, place pin in end of tool on outside of housing and second pin on inside, then apply pressure to tool so that pin on end of bar deforms housing inward. NOTE: Be sure and deform housing enough over springs so they are retained in housing.
8. Install quick coupler kit. Unscrew four hex nuts to end of stud so that clutch springs are completely released.
9. Clutch is now complete and ready for assembly on machine.

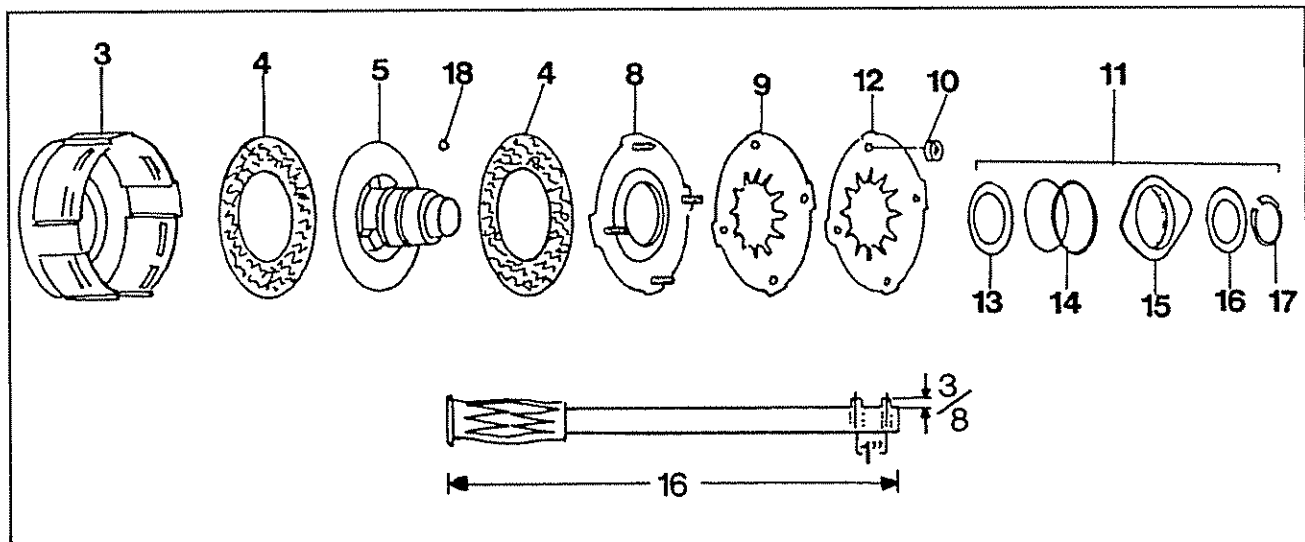



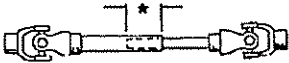

FIGURE 27

# MAINTENANCE





## DANGER

1. MAKE CERTAIN DRIVELINES ARE OF THE **CORRECT LENGTH** AND **SECURELY ATTACHED**. **DRIVELINE SEPARATION AND/OR PTO STUB SHAFT FAILURE CAN CAUSE INJURY OR DEATH.** (See Operator's Manual for procedure.)

<p><small>* SEE MANUAL FOR MINIMUM OVERLAP &amp; MINIMUM/MAXIMUM LENGTHS</small></p> 	
--	--

2. MAKE CERTAIN THAT DRIVELINE SHIELDS ARE **INSTALLED CORRECTLY** AND **TURN FREELY** TO PREVENT INJURY OR DEATH FROM ENTANGLEMENT

	
---	--

3. IF DRIVELINE SHIELDS HAVE TETHER CHAINS, **ATTACH TETHER CHAINS SECURELY TO MOWER AND TRACTOR** TO PREVENT SHIELD ROTATION, BELL AND/OR SHIELD FAILURE AND SERIOUS INJURY OR DEATH.

4. 540 PTO RPM UNLESS SPECIFICALLY MARKED OTHERWISE. 00756494



## DANGER



**ROTATING DRIVELINE**  
CONTACT CAN CAUSE DEATH  
**KEEP AWAY!**

DO NOT OPERATE WITHOUT—

- ALL DRIVELINE, TRACTOR AND EQUIPMENT SHIELDS IN PLACE
- DRIVELINES SECURELY ATTACHED AT BOTH ENDS
- DRIVELINE SHIELDS THAT TURN FREELY ON DRIVELINE

00756005



## DANGER



**SHIELD MISSING**  
**DO NOT OPERATE**



## DANGER



00756004

**SHIELD MISSING**  
**DO NOT OPERATE**



## DANGER

# MAINTENANCE

## HARDWARE

### TORQUE CHART (FIGURE 29)

Check nuts, bolts, and other miscellaneous hardware regularly. Loose hardware is easily lost, causes increased wear on parts, and increases the chance of breakdown. Loose hardware creates potential hazards which could result in personal injury to the operator, support personnel, and bystanders. Use the "Torque Chart" below when tightening bolted connections.



RECOMMENDED TORQUE IN FT-LBS (Nm) COARSE AND FINE THREADS			
2 (B)  5 (D)  8 (F) 			
Bolt Diameter	Plain Head	Three Dashes	Six Dashes
1/4	Not used	10 (14)	14 (19)
5/16	Not used	20 (27)	30 (41)
3/8	Not used	35 (47)	50 (68)
7/16	35 (47)	55 (75)	80 (108)
1/2	55 (75)	85 (115)	120 (163)
9/16	75 (102)	130 (176)	175 (237)
5/8	105 (142)	170 (230)	240 (325)
3/4	185 (251)	300 (407)	425 (576)
7/8	160 (217)	445 (603)	685 (929)
1	250 (339)	670 (908)	1030 (1396)
1-1/8	330 (447)	910 (1234)	1460 (1979)
1-1/4	480 (651)	1250 (1695)	2060 (2793)

FIGURE 29

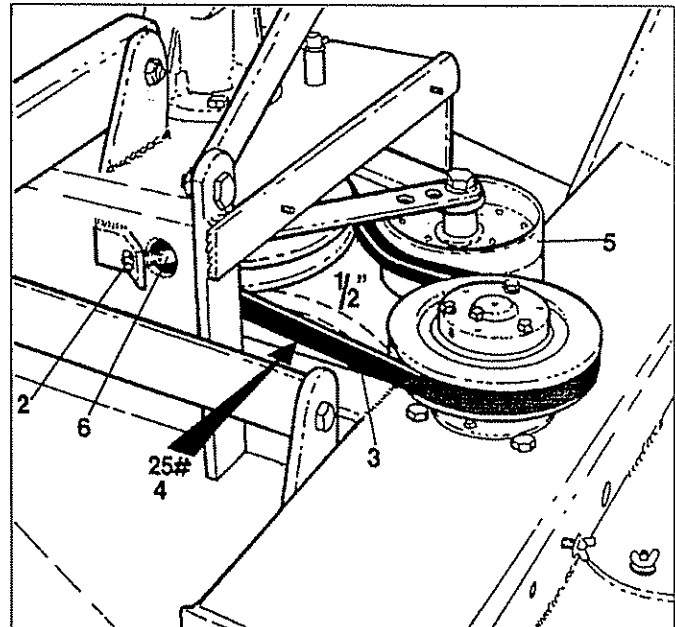

FIGURE 30

### BELT REPLACEMENT

Remove wing nut and remove belt shield (not shown). Remove nut and push idler pulley (1) out of the way. Install belt (2) in matching grooves in pulleys. Pull idler against belt, insert adjusting bolt through hole in adjusting anchor, install nut and adjust as shown in figure 30.

### BELT ADJUSTMENT

Remove wing nuts and remove belt shield (not shown). Turn adjusting nut on Idler Pivot (3) clockwise to tighten belt (2) and CCW to loosen belt. Tighten nut until a 25 lb. force will cause approximately 1/2" deflection as shown in figure 30.

# PARTS SECTION

## PARTS ORDERING GUIDE

The following instructions are offered to help eliminate needless delay and error in processing purchase orders for the equipment in this section.

1. The Parts Section is prepared in logical sequence and grouping of parts that belong to the basic machine featured in this manual. Part Numbers and Descriptions are given to help locate the parts and quantities required.
2. The Purchase Order must include the name and address of the person or organization ordering the parts, who should be charged, and if possible, the serial number of the machine for which the parts are ordered.
3. The Purchase Order must clearly list the quantity of each part, the complete and correct part number, and the basic name of the part.
4. The Manufacturer reserves the right to substitute parts where applicable.
5. Some parts are unlisted items which are special production items not normally stocked and are subject to special handling. Request a quotation for such parts before sending a Purchase Order.
6. The Manufacturer reserves the right to change prices without prior notice.

**NOTE:** Please refer to The Safety Section in the front of this Manual for the proper Part Number when ordering Replacement Safety Decals.



For maximum safety and to guarantee optimum product reliability, always use genuine Alamo Group Parts. The use of inferior replacement parts may cause premature or catastrophic failure which could result in serious injury or death. Direct any questions regarding parts to:



**Alamo**

P.O. Drawer 549

Seguin, Texas

78156

512-372-3551



# TABLE OF CONTENTS

Skid and Shield Assembly .....	4
Pulley and Bearing Assembly .....	5
Hitch and Tail Wheel Assembly - Lift Model .....	6
Hitch and Tail Wheel Assembly - Pull Model .....	7
Spindle Assembly .....	8
Main Driveline - Lift Model .....	9
Slip Clutch - Lift Model .....	10
"Discontinued" Main Driveline - Lift Model thru S/N 10040 .....	11
"Discontinued" Slipclutch - Lift Model thru S/N 10040 .....	12
Driveline Cat IV - Pull Model .....	13
"Discontinued" Driveline Cat IV - Pull Model thru S/N 10051 .....	14
Jackshaft - Pull Model .....	15
Slip Clutch Pull Model .....	16
"Discontinued" Jackshaft - Pull Model thru S/N 10051 .....	17
"Discontinued" Slipclutch - Pull Model thru S/N 10051 .....	18
Jackshaft Bearing Support.....	19
"Discontinued" Jackshaft Bearing Support thru S/N 10051 .....	20
Gearbox Assembly .....	21-22
Front Chainguard - Single and Double Curtain .....	23
Rear Chainguard - Single and Double Curtain .....	24
Front Deflector .....	25
Rear Deflector .....	26
Hydraulic Cylinder Assembly .....	27
Hydraulic Relief Assembly .....	28
Wheel Group .....	29
Wheel Hub Assembly .....	30
Tail Wheel Assembly .....	31
Blade Bar Assembly .....	32
Blade Pan Assembly .....	33
Spring Shock Assembly .....	34
Hitch Extension Kit.....	35

# SKID AND SHIELD ASSEMBLY

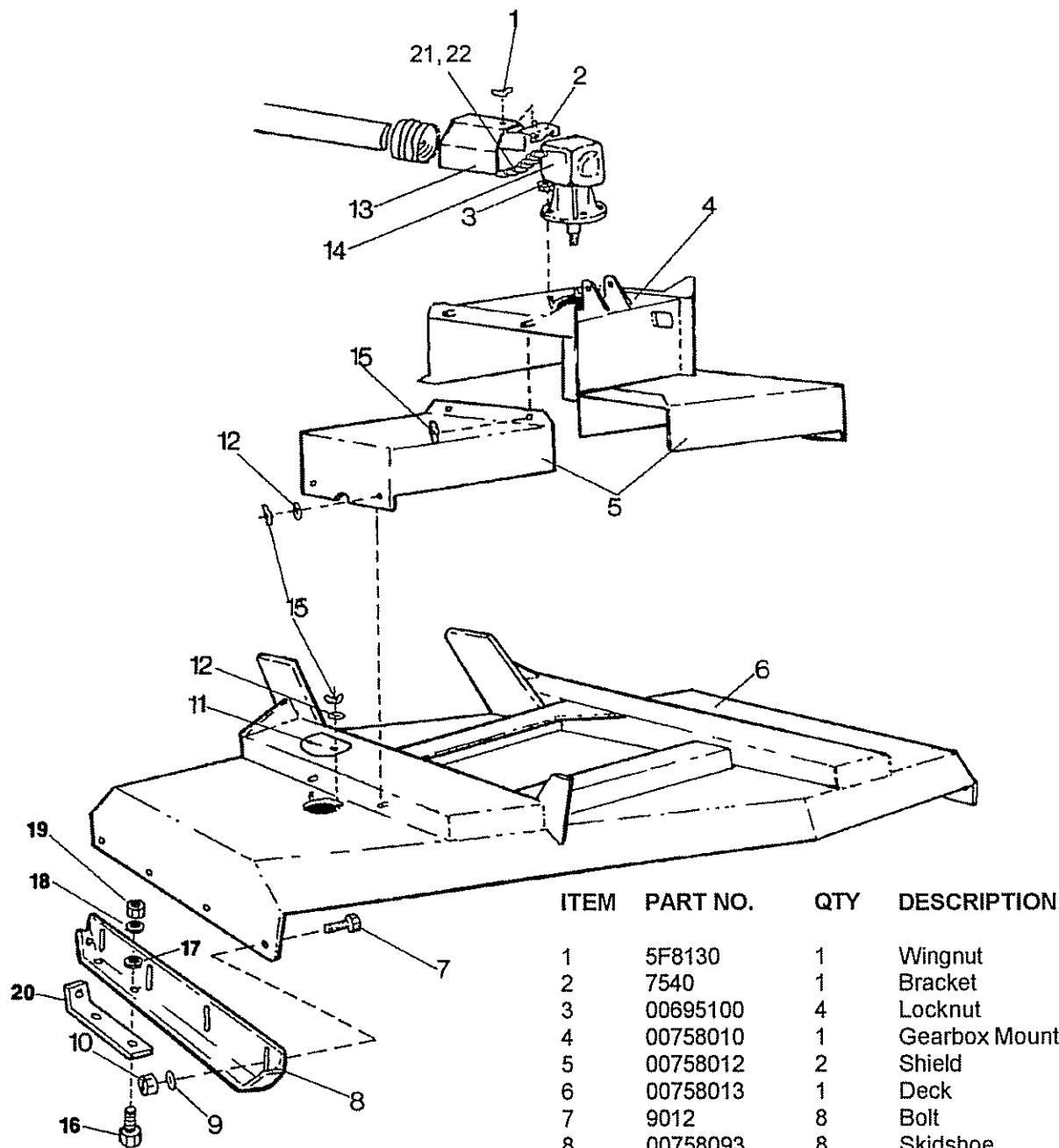

**NOTE: THIS ASSEMBLY IS COMMON TO BOTH PULL AND LIFT MODELS.**

ITEM	PART NO.	QTY	DESCRIPTION
1	5F8130	1	Wingnut
2	7540	1	Bracket
3	00695100	4	Locknut
4	00758010	1	Gearbox Mount
5	00758012	2	Shield
6	00758013	1	Deck
7	9012	8	Bolt
8	00758093	8	Skidshoe
9	9067	8	Flatwasher
10	00001800	8	Nut
11	00757948	2	Inspection Cover
12	8241	8	Flatwasher
13	7541	1	Shield
14	00758959	1	Gearbox
15	9209	12	Wingnut
16	8277	6	Bolt
17	3078	6	Washer
18	4331	6	Washer
19	4378	6	Nut
20	8312	2	Skid Runner (Optional)
21	00764259	1	Chain
22	4405	2	Cotter Pin

# PULLEY AND BEARING ASSEMBLY

**NOTE: THIS ASSEMBLY IS  
COMMON TO BOTH PULL  
AND LIFT MODELS.**

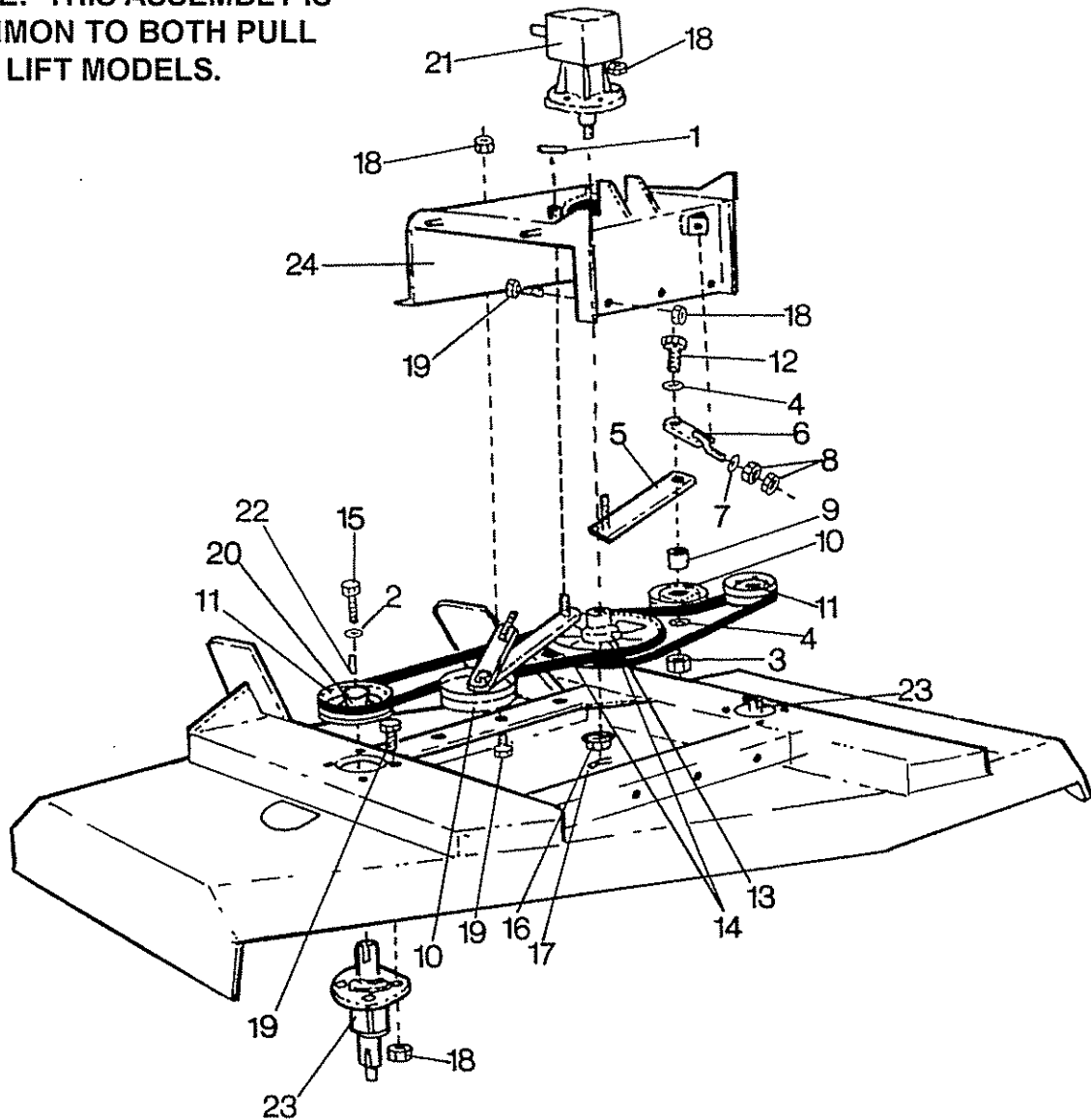

ITEM	PART NO.	QTY	DESCRIPTION	ITEM	PART NO.	QTY	DESCRIPTION
1	5427	2	Roll Pin	13	00759248	1	Pulley
2	00755954	6	Lockwasher	14	00758086	2	V-Belt
3	5JRC12100	2	Locknut	15	02961228	6	Capscrew (Metalic)
4	15B1200	2	Washer	16	00758692	1	Nut
5	00757960	2	Idler Pivot	17	7343	14	Cotter
6	00758038	2	Idler Linkage	18	00695100	18	Locknut
7	3078	2	Flatwasher	19	4386	14	Bolts
8	4378	4	Nut	20	00758786	2	Bushing (Tap or Lock)
9	00757959	2	Bushing	21	00758959	1	Gearbox
10	00758085	2	Idler Pulley	22	00758211	2	Key
11	00758784	2	Pulley	23	00758958	2	Spindle
12	4723	2	Bolt	24	00758010	1	Gearbox Mount

# HITCH & TAILWHEEL ASSEMBLY

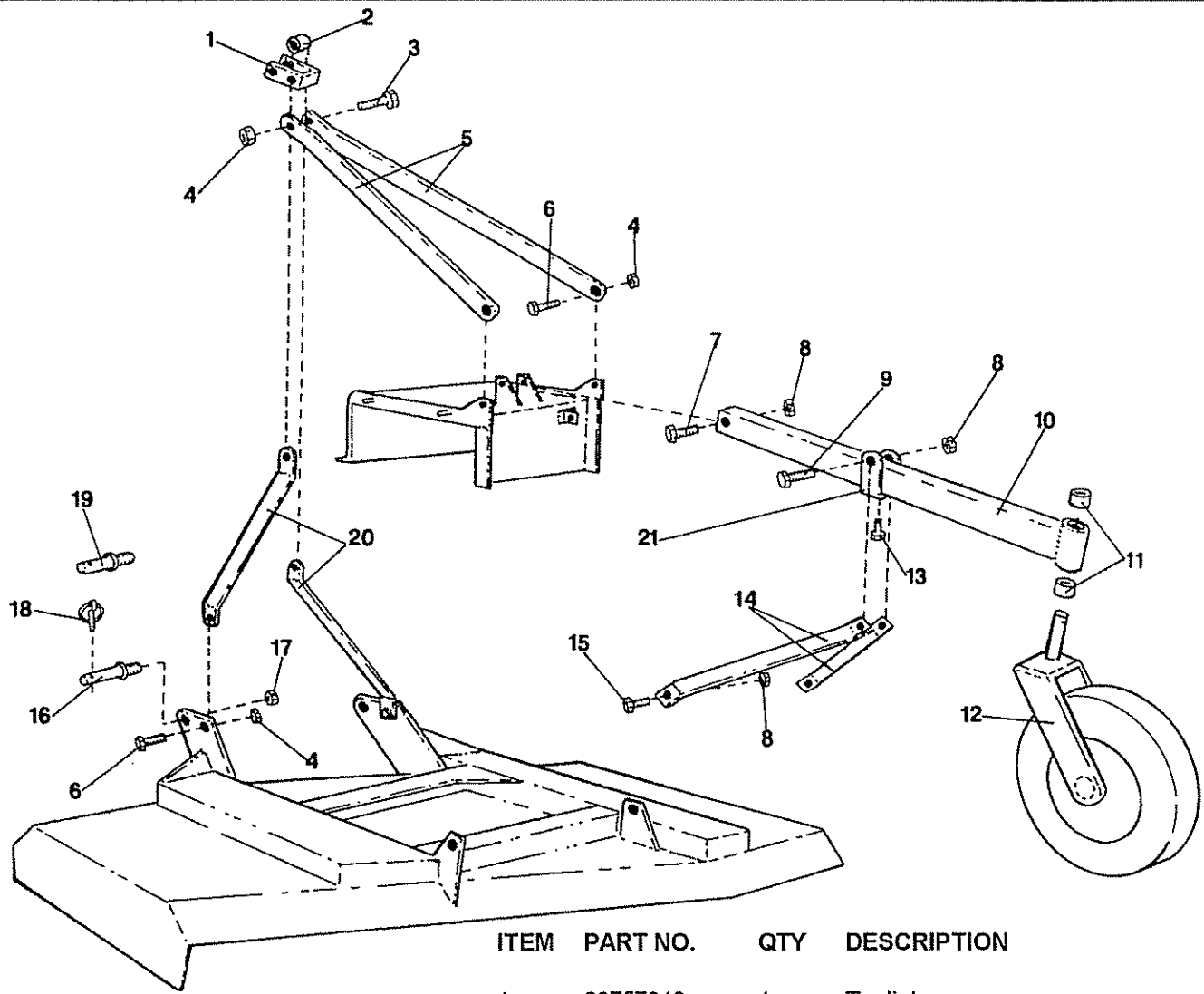

**NOTE: THIS ASSEMBLY  
FOR LIFT MODELS ONLY.**

ITEM	PART NO.	QTY	DESCRIPTION
1	00757949	1	Toplink
2	00757953	1	Bushing
3	02025700	1	Bolt
4	00037200	5	Locknut
5	00758000	2	Brace (Long)
6	4398	4	Bolt
7	8238	1	Bolt
8	00695100	4	Locknut
9	4421	1	Bolt
10	00758003	1	Tailwheel Tube Assembly
11	361129	2	Bushing
12	B742023	1	Caster Fork & Wheel
13	3167	1	Set Screw
14	00757967	2	Bar Axle Arm Adjustment
15	8236	2	Bolt
16	441027	2	Category II Hitch Pin (Standard)
17	4566	2	Locknut
18	2196	2	Lynch Pin
19	00603500	2	Category I Hitch Pin (Optional)
20	00757950	2	Brace (Short)
21	00757942	2	Axle Adjustment

# HITCH AND REAR AXLE ASSEMBLY

NOTE: THIS ASSEMBLY  
FOR PULL MODELS ONLY.

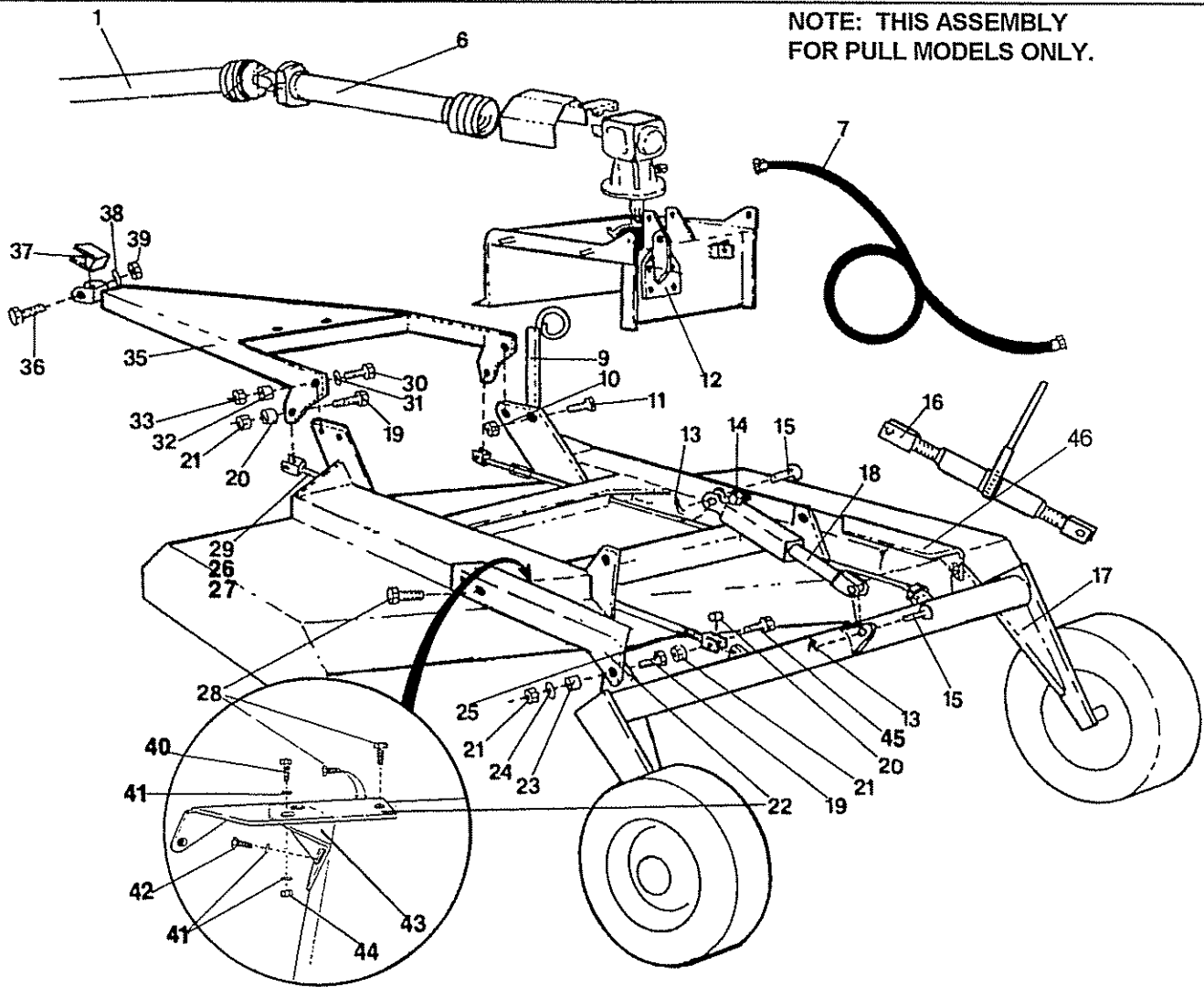

ITEM	PART NO.	QTY	DESCRIPTION	ITEM	PART NO.	QTY	DESCRIPTION
1	00759325	1	Shaft	26	8305	2	Turnbuckle
6	00759343	1	Shaft	27	5C1490	2	Jamnut
7	B65113A2	1	Hydraulic Hose & Fitting	28	4338	5	Bolt
9	0691320100	1	Hose Bracket	29	00758182	2	Level Rod (Long)
10	00695100	1	Nut	30	4621	2	Bolt
11	8236	1	Bolt	31	4583	2	Washer
12	00758184	1	Cylinder Bracket	32	00758196	2	Bushing
13	2192	2	Cotter Pin	33	5JRC1490	2	Nut
14	94514	1	Elbow	35	00758163	1	Tongue
15	8354	2	Pin	36	7341	1	Bolt
16	2108	1	Ratchet	37	00748807	1	Clevis
17	00758380	1	Axle with Hub	38	00757478	1	Washer
18	8727	1	Cylinder	39	5JRC1680	1	Nut
19	8252	2	Bolt	40	4400	2	Bolt
20	8327	4	Bushing	41	9067	6	Washer
21	00037200	6	Nut	42	4399	2	Bolt
22	00758190	1	Axle Arm	43	00759670	1	Brace
23	00758017	2	Bushing	44	00001800	2	Nut
24	8248	2	Washer	45	8357	4	Bolt
25	8449	2	Level Rod (Short)	46	00758189	1	Axle Arm

# SPINDLE AND HOUSING ASSEMBLY

SPINDLE (P/N 00758200 w/Pulley)  
 SPINDLE (P/N 00758958 Less Pulley)

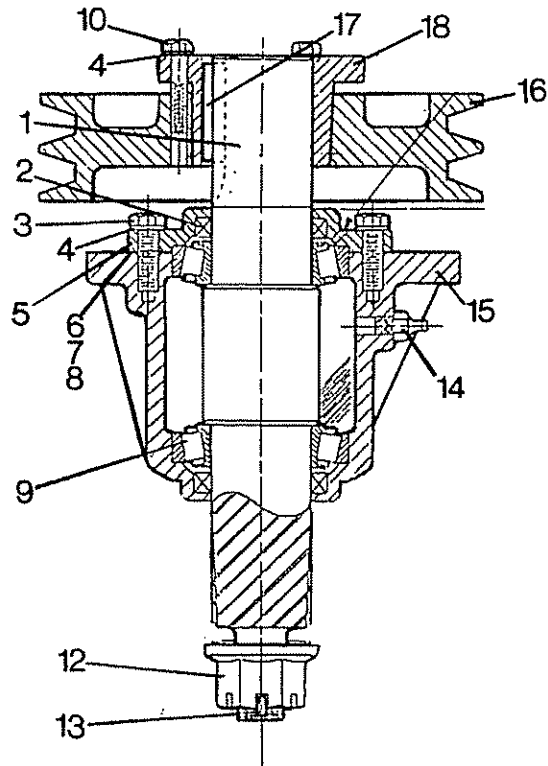

ITEM	PART NO.	QTY	DESCRIPTION
1	00758780	1	Shaft
2	00758674	2	Seal
3	00758659	4	Cap Screw
4	00755954	7	Lockwasher
5	00758781	1	Cap
6	00758723	1	Shim .004
7	00758724	1	Shim .012
8	00758725	1	Shim .020
9	00758650	2	Bearing
10	02961228	3	Cap Screw
12	00758692	1	Hex Nut
13	00606000	1	Cotter Pin
14	00758782	1	Grease Fitting
15	00758783	1	Spindle Housing
16	00758784	1	Pulley
17	00758785	1	Key
18	00758786	1	Bushing

# MAIN DRIVELINE ASSY - LIFT TYPE (P/N 00759322)

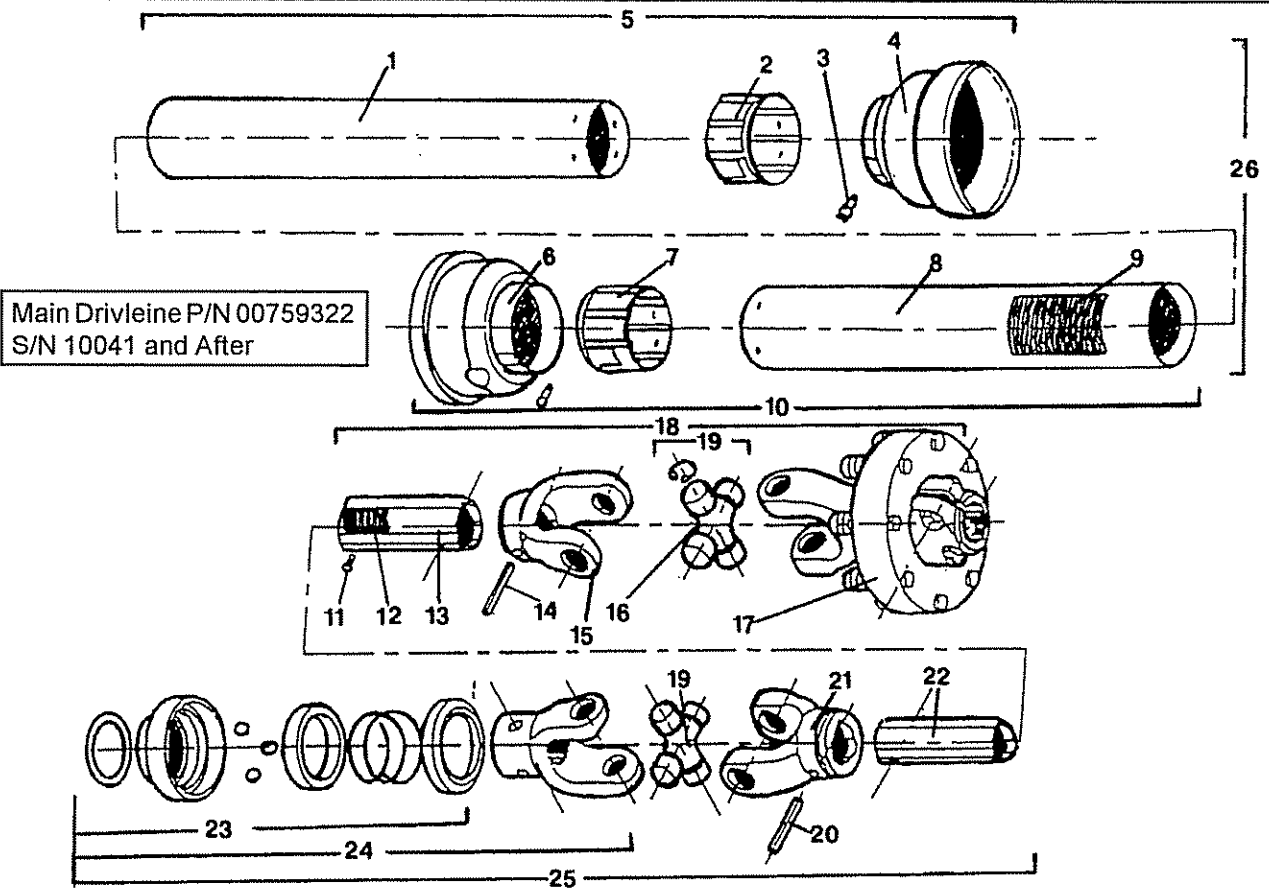

ITEM	PART NO.	QTY	DESCRIPTION
1	00759953	1	Inner Tube
2	00759216	1	Inner Tube Bearing
3	00759217	2	Screw
4	00759842	1	Short Cone
5	00759955	1	Inner Shield Half
6	00759844	1	Standard Cone
7	00759218	1	Outer Tube Bearing
8	00759954	1	Outer Tube
9	00756005	1	Danger Decal
10	00759956	1	Outer Shield Half
11	00754335	1	Grease Fitting
12	00756004	1	Danger Decal
13	00759949	1	Outer Tube
14	00754167	1	Outer Tube Roll Pin
15	00754154	1	Outer Tube Yoke
16	00759517	2	Cross Grease Fitting
17	00754320	1	Complete Disc Clutch
18	00759951	1	Outer Shaft w/Protector
19	00752896	2	Cross Assembly
20	00754167	1	Inner Tube Roll Pin
21	00754153	1	Inner Tube Yoke
22	00759950	1	Inner Tube
23	00757144	1	Collar Kit
24	00752883	1	Collar Yoke
25	00759952	1	Innershaft w/Protector
26	00759957	1	Complete Shield

# SLIPCLUTCH ASSEMBLY - LIFT MODEL (P/N 00754320)

Slipclutch P/N 00754320  
S/N 10041 and After

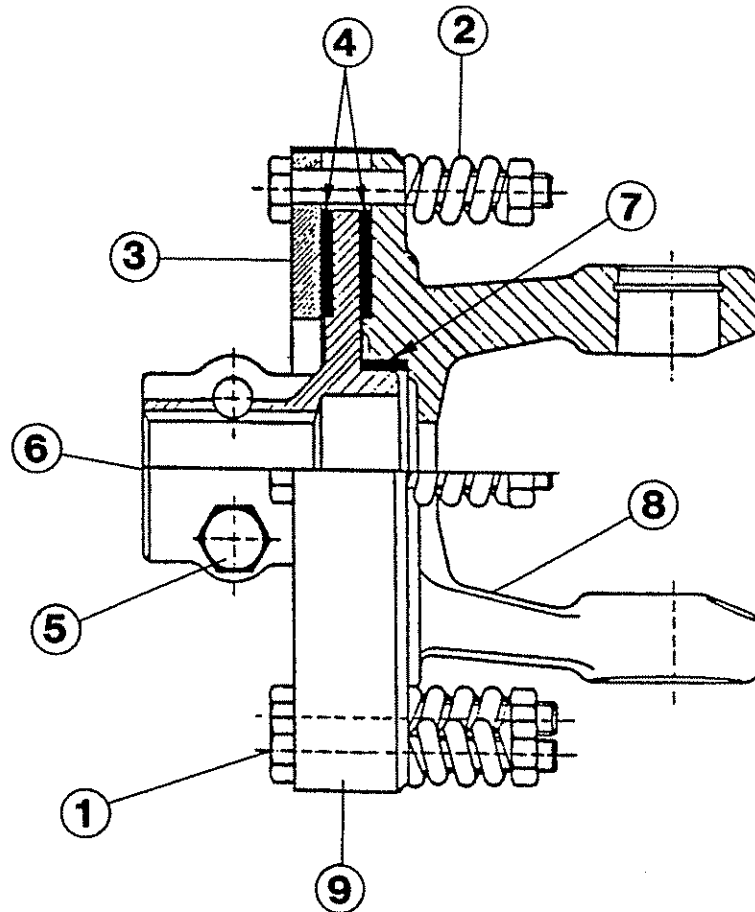

ITEM	PART NO.	QTY	DESCRIPTION
1	00754316	8	Bolt
2	00754315	8	Spring
3	00754203	1	Outer Flange
4	00754202	2	Disk
5	00752903	2	Bolt & Nut
6	00754317	1	Body-Friction Clutch
7	00754301	1	Spacer
8	00754302	1	Yoke Friction
9	00754318	1	Dirt Shield



# MAIN DRIVELINE ASSEMBLY - LIFT TYPE (P/N 8895)

Main Driveline P/N 8895  
S/N 10040 and Prior

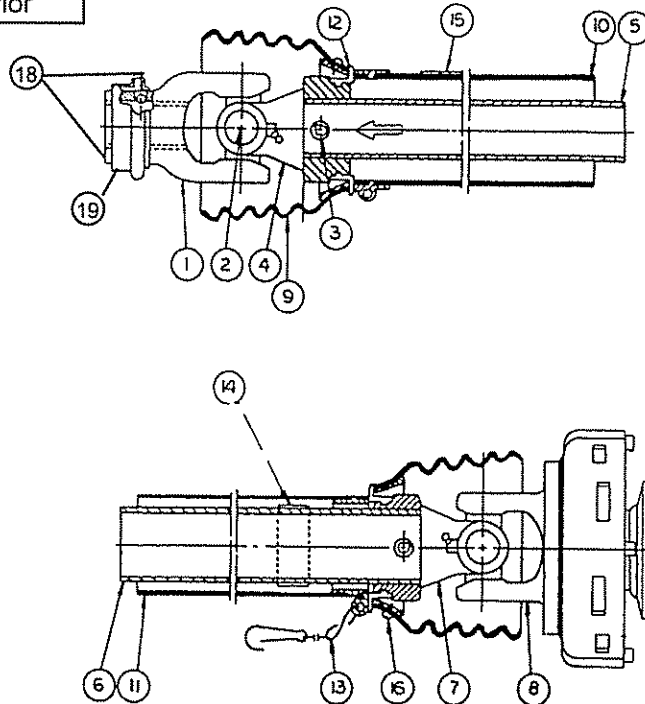

ITEM	PART NO.	QTY	DESCRIPTION
1	8923	1	Yoke
2	8925	2	Cross & Bearing Kit
3	8945	2	Spring Pin
4	8944	1	Inboard Yoke
5	8946	1	Inner Profile
6	8947	1	Outer Profile
7	8948	1	Inboard Yoke
8	8970	1	Friction Clutch
9	8949	2	Shield Cone
10	8950	1	Outer Shield Tube
11	8951	1	Inner Shield Tube
12	8393	2	Bearing Ring
13	0921000345	1	Safety Chain
14	00756004	1	Decal
15	00756005	1	Decal
18	8371	1	QD Flange Kit
19	8445	1	Collar

# SLIP CLUTCH ASSEMBLY - LIFT TYPE (P/N 8970)

Slipclutch P/N 8970  
S/N 10040 and Prior

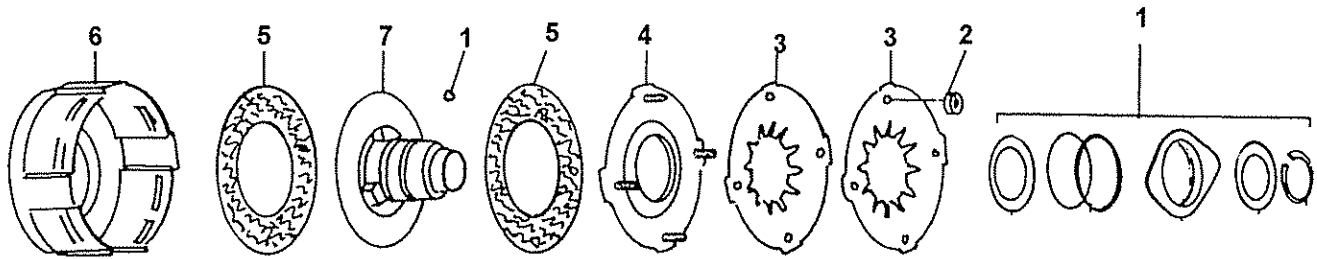

ITEM	PART NO.	QTY	DESCRIPTION
1	8371	1	Flange QD Kit
2	8425	4	Hex Nut
3	8369	2	Belleville Spring
4	8465	1	Thrust Plate
5	8366	2	Friction Disk
6	8978	1	Clutch Housing
7	8367	1	Hub

# DRIVELINE ASSY CAT IV - PULL TYPE (P/N 00759325)

Driveline P/N 00759325  
S/N 10052 and After

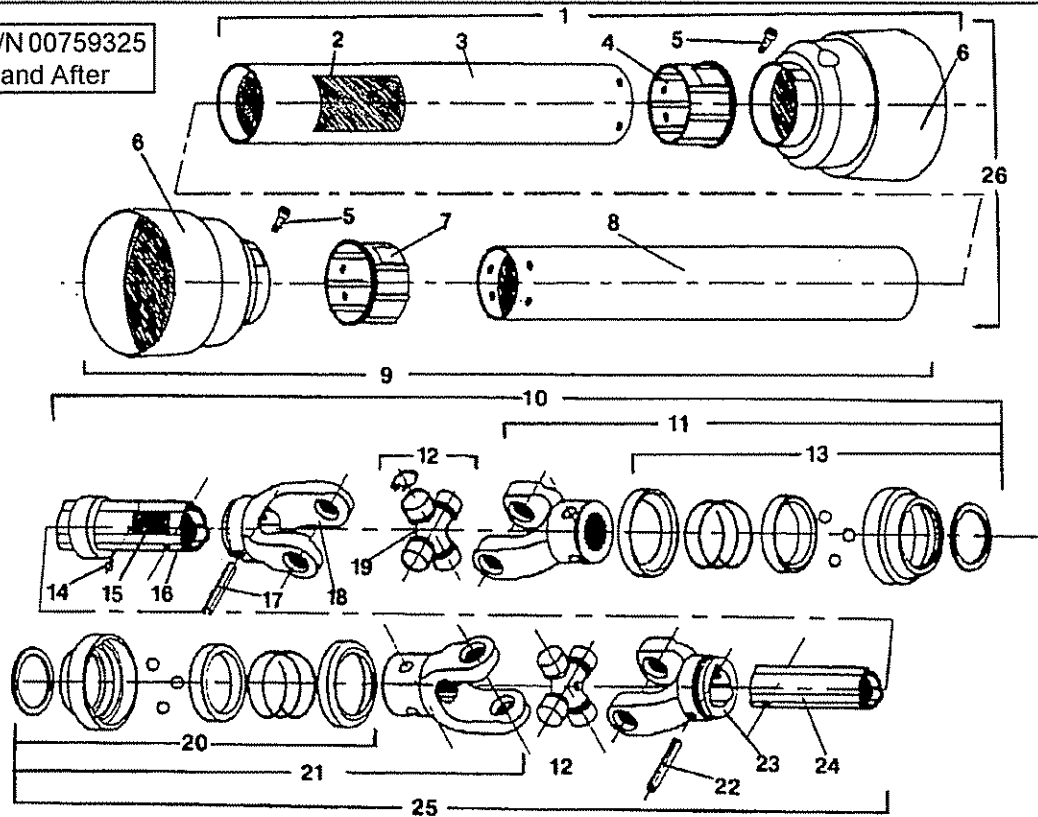

ITEM	PART NO.	QTY	DESCRIPTION
1	00759876	1	Outer Shield Half
2	00756005	1	Decal, Danger Rotating Driveline
3	00759874	1	Outer Tube
4	00759218	1	Outer Tube Bearing
5	00759217	2	Screw
6	00759844	2	Standard Cone
7	00759216	1	Inner Tube Bearing
8	00759873	1	Inner Tube
9	00759875	1	Inner Shield Half
10	00759869	1	Outer Shaft w/Protector
11	00752883	1	Collar Yoke
12	00752896	2	Cross Assembly
13	00757144	1	Yoke Collar Repair Kit
14	00754335	1	Grease Fitting
15	00756004	1	Decal, Danger Shield Missing
16	00759871	1	Outer Tube
17	00754167	1	Outer Tube Roll Pin
18	00754154	1	Outer Tube Yoke
19	00759517	2	Grease Fitting
20	00757052	1	Yoke Collar Repair Kit
21	00757051	1	Yoke Collar
22	00754167	1	Inner Tube Roll Pin
23	00754153	1	Inner Tube Yoke
24	00759872	1	Inner Tube
25	00759870	1	Inner Shaft w/Protector
26	00759877	1	Complete Shield

# DRIVLEINE ASSY CAT IV - PULL TYPE (P/N 00758053)

Driveline P/N 00758053  
S/N 10051 and Prior

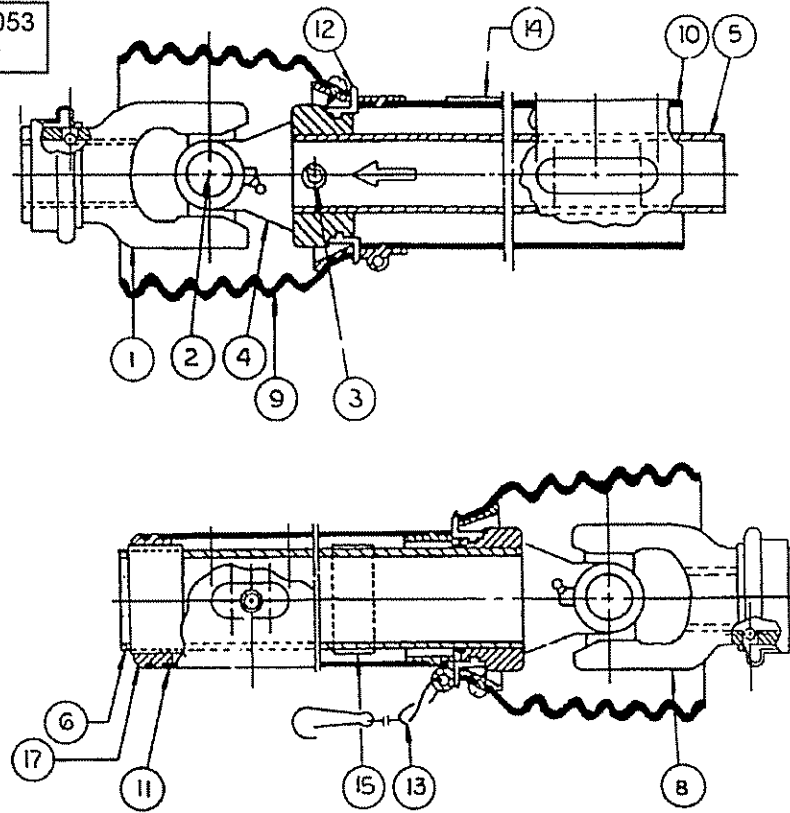

ITEM	PART NO.	QTY	DESCRIPTION
1	8983	1	Yoke
2	8388	2	Cross & Bearing Kit
3	8384	1	Spring Pin
4	8982	1	Inboard Yoke
5	00758449	1	Inner Profile
6	00758451	1	Sleeve
8	00758452	1	Yoke
9	8949	2	Shield Cone
10	00758453	1	Outer Shield Tube
11	00758454	1	Inner Shield Tube
12	8393	2	Bearing Ring
13	0921000345	1	Safety Chain
14	00756005	1	Decal, Danger Rotating Driveline
15	00756004	1	Decal, Danger Shield Missing
17	8974	1	Support Bearing
*	8445	2	Collar Kit

# JACKSHAFT ASSEMBLY - PULL TYPE (P/N 00759343)

Jackshaft P/N 00759343  
S/N 10052 and After

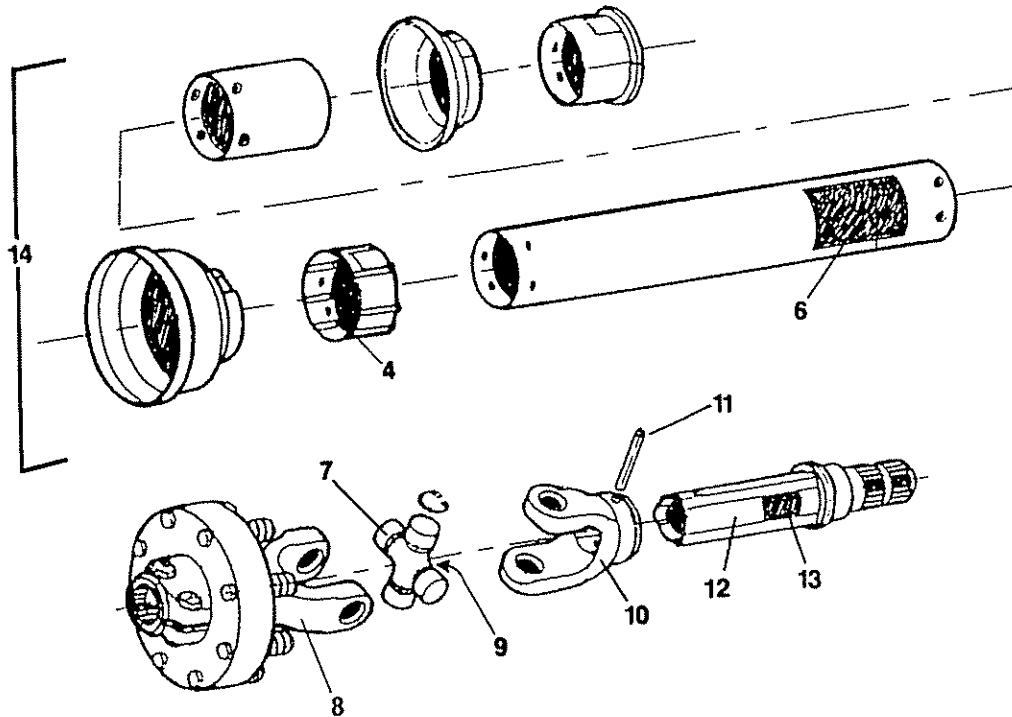
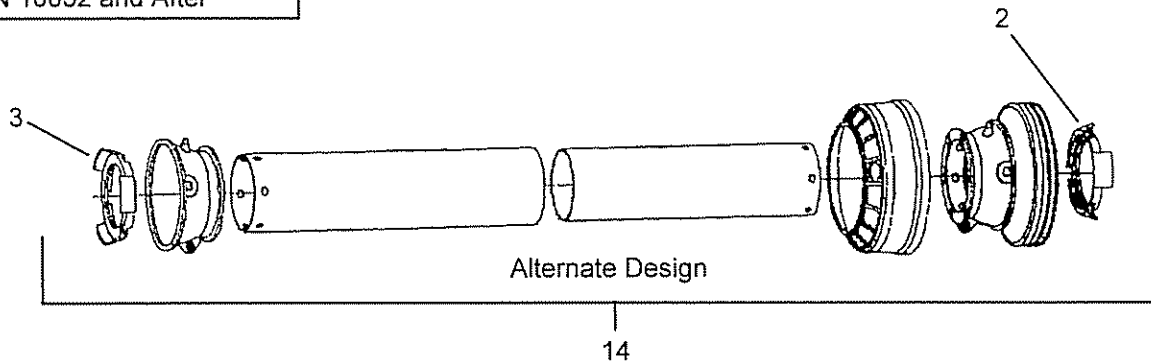

ITEM	PART NO.	QTY	DESCRIPTION
2	00763196	1	Inner Tube Bearing
3	00763195	1	Outer Tube Bearing
4	00759218	1	Outer Tube Bearing
6	00756005	1	Safety Decal
7	00752896	1	Cross Assembly
8	00759948	1	Complete Disc Clutch
9	00759517	1	Grease Fitting
10	00754154	1	Outer Tube Yoke
11	00754167	1	Roll Pin
12	00760672	1	Shaft
13	00756004	1	Safety Decal
14	00760674	1	Complete Shield

# SLIPCLUTCH ASSEMBLY (P/N 00759948)

Slipclutch P/N 00759948  
S/N 10052 and After

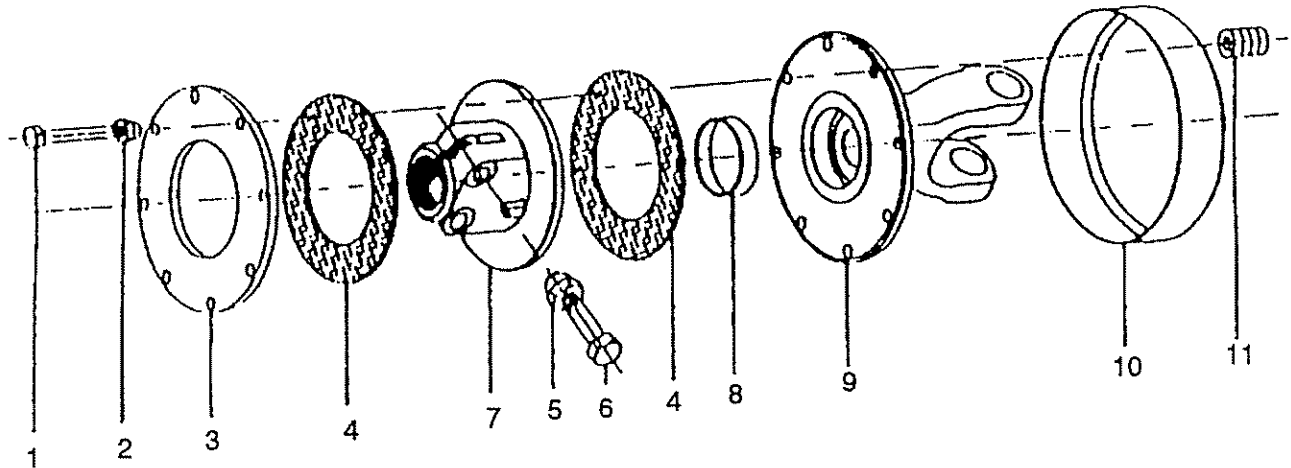

ITEM	PART NO.	QTY	DESCRIPTION
1&2	00754316	8	Nut & Bolt
3	00754203	1	Pressure Plate
4	00754202	2	Clutch Lining
5&6	00752903	2	Nut & Bolt
7	00754300	1	Clutch Support
8	00754301	1	Bushing
9	00754302	1	Flanged Yoke
10	00754318	1	Dirt Shield
11	00754315	8	Spring

# JACKSHAFT ASSEMBLY - PULL TYPE (P/N 00758091)

Jackshaft P/N 00758091  
S/N 10051 and Prior

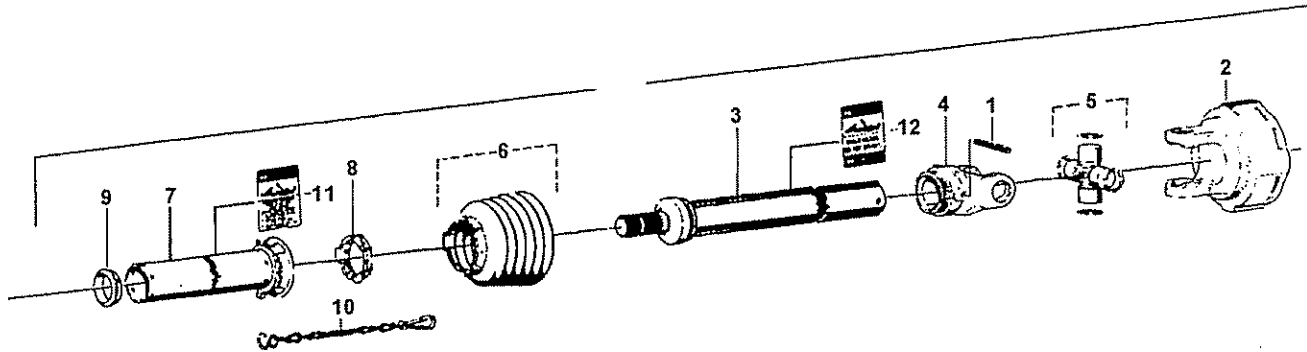

ITEM	PART NO.	QTY	DESCRIPTION
1	8384	1	Spring Pin
2	8914	1	Friction Clutch
3	00758457	1	Shaft Weldment
4	8387	1	Inboard Yoke
5	8388	1	Cross & Bearing Kit
6	8949	1	Shield Cone
7	00758458	1	Inner Shield Tube
8	8393	1	Bearing Ring
9	8974	1	Support Bearing
10	0921000345	1	Safety Chain
11	00756005	1	Decal, Danger Rotating Driveline
12	00756004	1	Decal, Danger Shield Missing

# SLIPCLUTCH (P/N 8914)

Slipclutch P/N 8914  
S/N 10051 and Prior

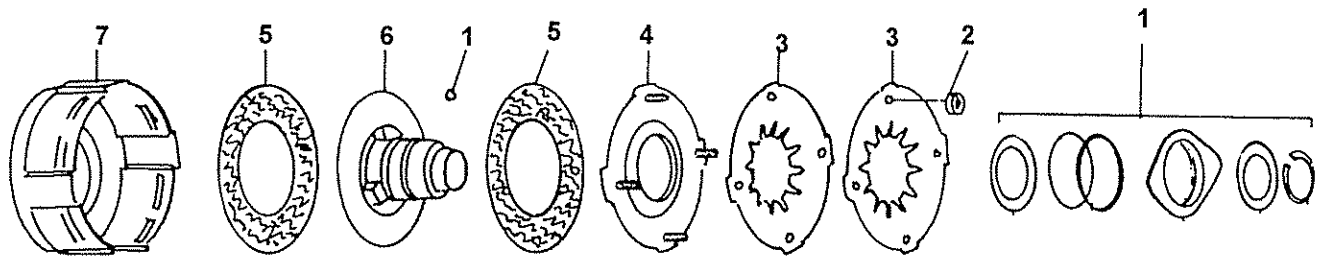

ITEM	PART NO.	QTY	DESCRIPTION
1	8371	1	Flange QD Kit
2	8427	4	Hex Nut
3	8369	2	Belleville Spring
4	8465	1	Thrust Plate
5	8366	2	Friction
6	8367	1	Hub
7	8980	1	Clutch Housing



# JACKSHAFT BEARING SUPPORT - PULL TYPE

Jackshaft Bearing Support  
S/N 10052 and After

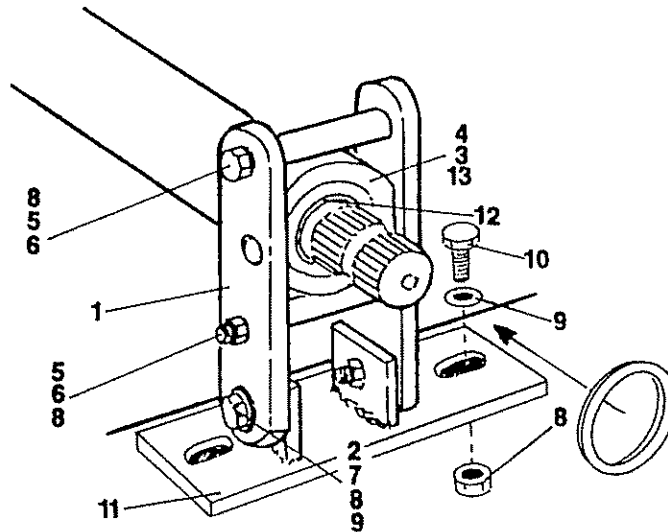

ITEM	PART NO.	QTY	DESCRIPTION
1	00759867	2	Jackshaft Support Flat
2	681112	2	Bushing
3	00759099	1	Bearing Housing
4	00759286	1	Bearing
5	531113	2	Bearing Space
6	4618	2	Bolt
7	00013300	2	Bolt
8	00001800	6	Locknut
9	9067	8	Washer
10	4338	2	Bolt
11	562142	1	Base Bracket
12	00759868	1	Spacer
13	00759100	1	Bearing & Housing Assembly

# JACKSHAFT BEARING SUPPORT

Jackshaft Bearing Support  
S/N 10051 and Prior

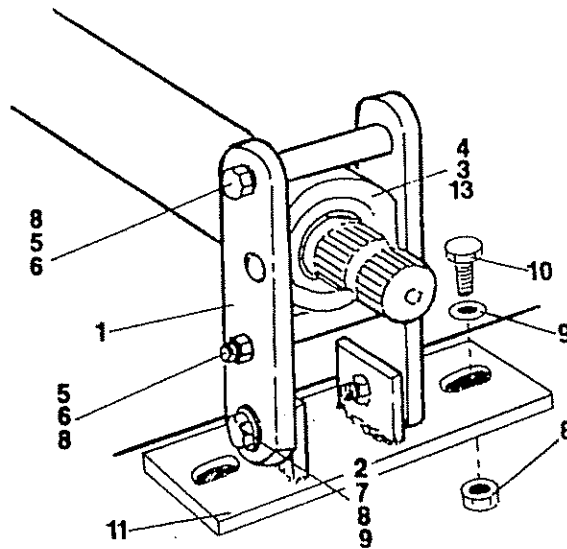

ITEM	PART NO.	QTY	DESCRIPTION
1	00759867	2	Jackshaft Support Flat
2	681112	2	Bushing
3	531111	1	Bearing Housing
4	531116	1	Bearing
5	531113	2	Bearing Space
6	4618	2	Bolt
7	00013300	2	Bolt
8	00001800	6	Locknut
9	9067	4	Washer
10	4338	2	Bolt
11	562142	1	Base Bracket
13	0811180010	1	Bearing & Housing Assembly

# GEARBOX

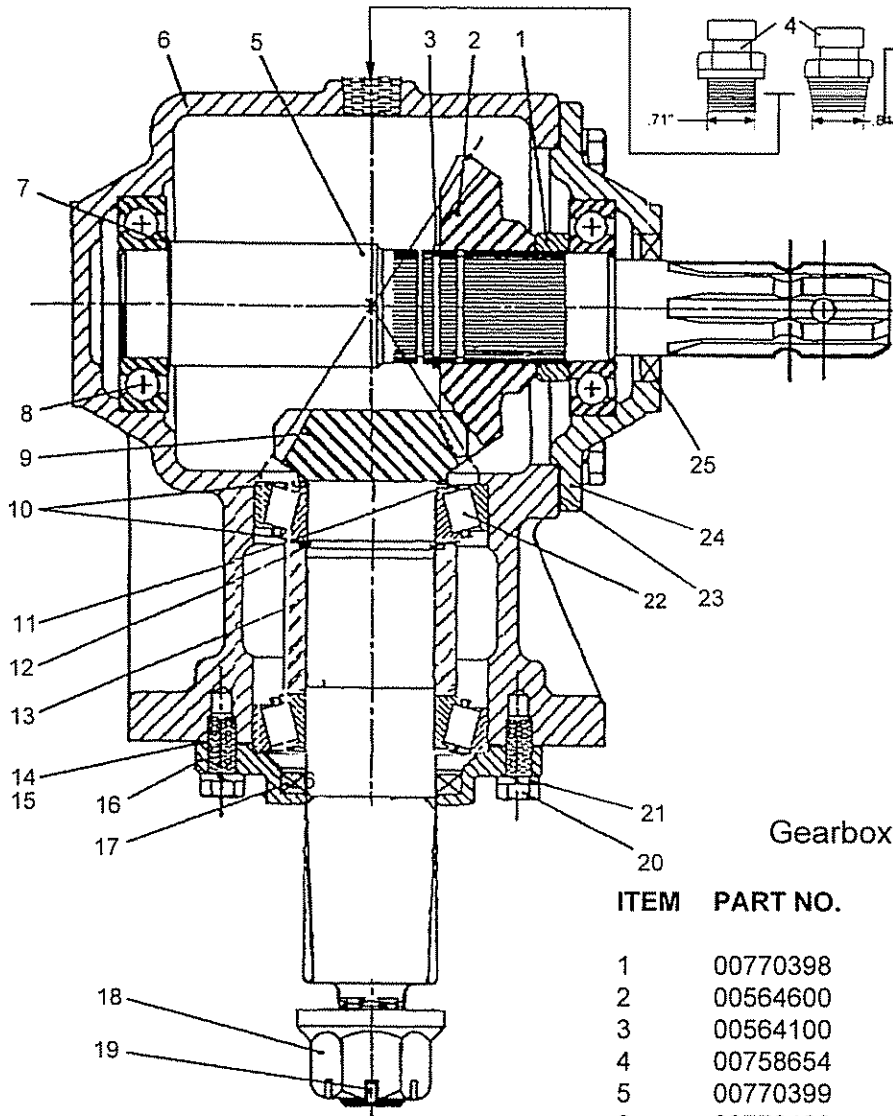

Gearbox P/N 00770367  
S/N 10221 and After

Gearbox P/N 00770367

ITEM	PART NO.	QTY	DESCRIPTION
1	00770398	1	Input Shaft Spacer
2	00564600	1	Input Gear
3	00564100	1	Retaining Ring
4	00758654	1	Breather Plug
5	00770399	1	Input Shaft
6	00770400	1	Housing
7	00758671	Req.	Shim 0.20
8	00563700	2	Ball Bearing
9	00770401	1	Pinion and Shaft
10	00770402	Req.	Pinion Adjusting Shim
11	00770403	1	Pinion Shim Spacer
12	00758660	1	Retaining Ring
13	00770368	1	Output Bearing Spacer
14	00760929	Req.	Output Cap Gasket 0.30
15	00760928	Req.	Output Cap Gasket 0.13
16	00758721	1	Output Cap
17	00758674	1	Output Oil Seal
18	00758692	1	Nut
19	00606000	1	Cotter Pin
20	00758659	10	Bolt
21	00755954	10	Lockwasher
22	00755628	2	Tapered Bearing
23	00564400	Req.	Gasket 0.30
24	00770404	1	Input Cap
25	00564200	1	Input Oil Seal

# GEARBOX

GEARBOX (P/N 00758959 Less Pulley)

Gearbox P/N 00758959  
S/N 10220 and Prior

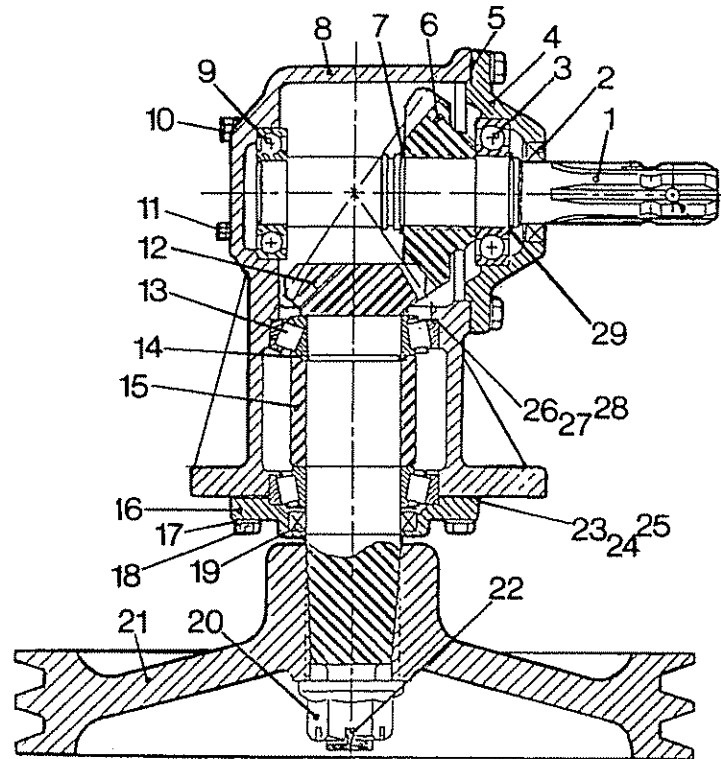

ITEM	PART NO.	QTY	DESCRIPTION	ITEM	PART NO.	QTY	DESCRIPTION
1	00758713	1	Input Shaft	15	00758720	1	Spacer
2	00564200	1	Seal	16	00758721	1	Output Cap
3	00563700	1	Bearing	17	00755954	10	Lockwasher
4	00764949	1	Input Cap	18	00758659	10	Cap Screw
5	00564400	1	Gasket	19	00758674	1	Seal
6	00758729	1	Gear	20	00758692	1	Hex Nut
7	00758715	1	Retaining Ring	21	00758734	1	Pulley
8	00758716	1	Housing	22	00606000	1	Cotter Pin
9	00564800	1	Bearing	23	00758723	2	Gasket
10	00758654	1	Relief Filler Plug	24	00758724	2	Gasket
11	00565000	1	Plug	25	00758725	1	Gasket
12	00758730	1	Pinion Gear	26	00758726	2	Shim
13	00758650	2	Bearing	27	00758727	2	Shim
14	00758660	1	Retaining Ring	28	00758728	1	Shim
				29	00564100	1	Retaining Ring

## FRONT CHAIN GUARD - SINGLE and DOUBLE CURTAIN (OPTIONAL)

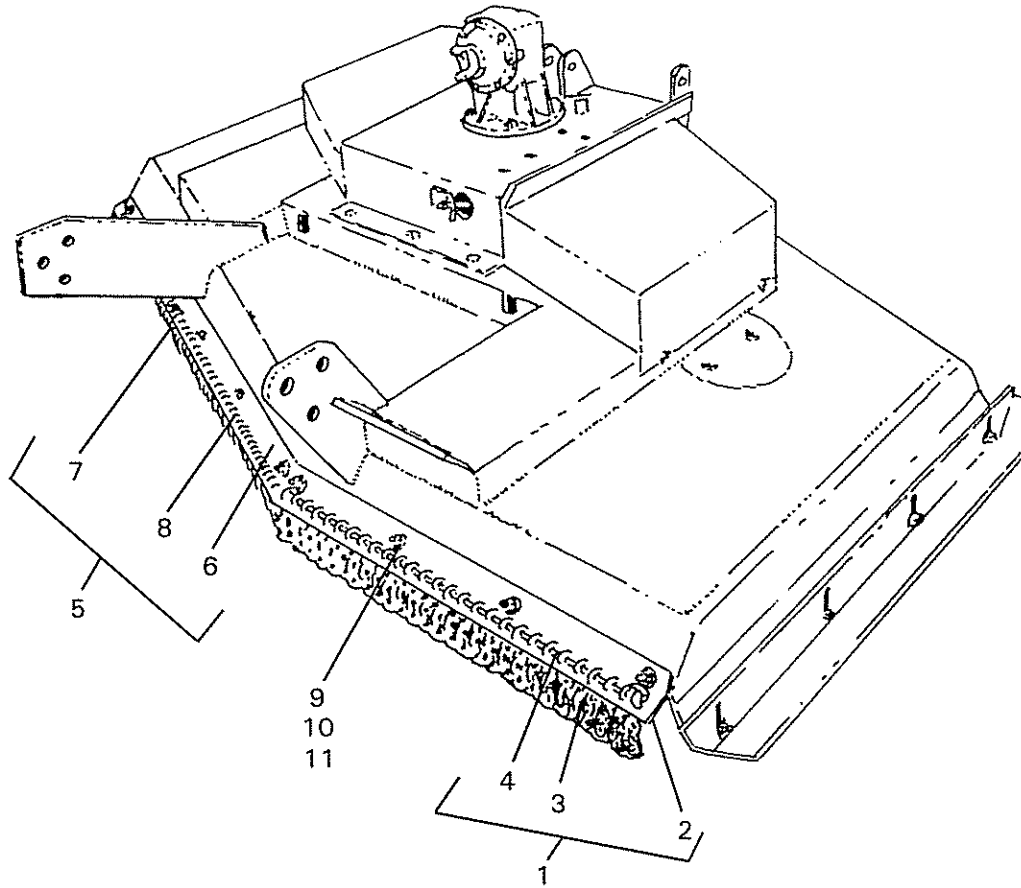

### FRONT CHAIN GUARD SINGLE

### FRONT CHAIN GUARD DOUBLE

ITEM	PART NO.	QTY	DESCRIPTION	ITEM	PART NO.	QTY	DESCRIPTION
1	00757988	1	Left Assembly	1	00758774	1	Right Assembly
2	00757993	1	Bar-Left	2	00758779	1	Bar - Right
3	00755090	28	Chain	3	00755090	59	Chain
4	00757961	1	Rod	4	00757964	2	Rod
5	00757989	1	Right Assembly	5	00758775	1	Left Assembly
6	00757992	1	Bar - Right	6	00758778	1	Bar - Left
7	00755090	47	Chain	7	00755090	36	Chain
8	00757964	1	Rod	8	00757961	2	Rod
9	02030700	10	Bolt	9	02030700	10	Bolt
10	00001800	10	Nut	10	00001800	10	Nut
11	00002700	10	Flatwasher	11	00002700	10	Flatwasher

## REAR CHAIN GUARD - SINGLE and DOUBLE CURTAIN (OPTIONAL)

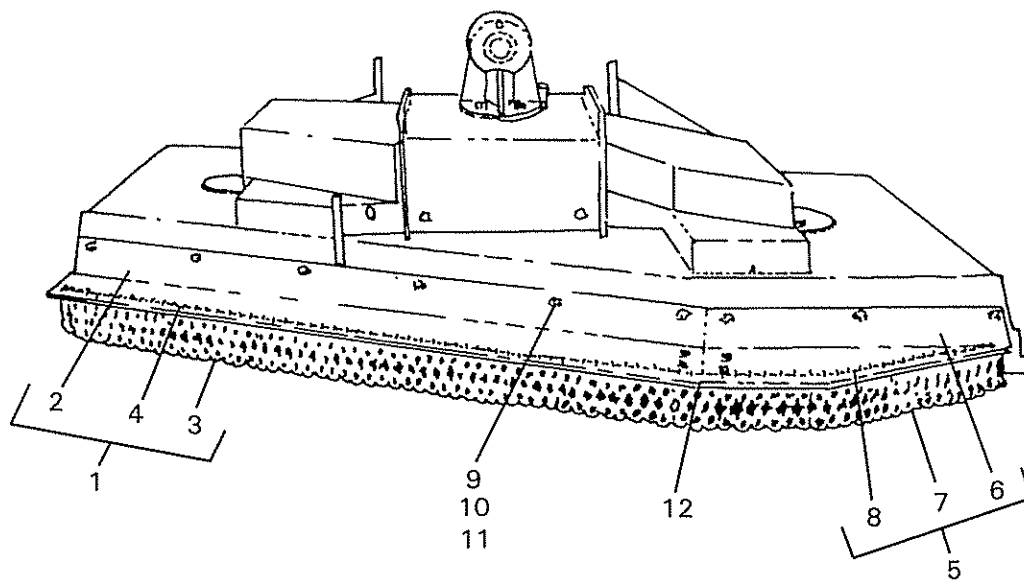

### REAR CHAIN GUARD SINGLE

ITEM	PART NO.	QTY	DESCRIPTION
1	00757990	1	Left Assembly
2	00757994	1	Plate
3	00755090	60	Chain
4	00757962	1	Rod
5	00757991	1	Right Assembly
6	00757995	1	Plate
7	00755090	23	Chain
8	00757963	1	Rod
9	02030700	13	Bolt
10	00001800	13	Nut
11	00002700	13	Flatwasher
12	00758195	1	Bar

### REAR CHAIN GUARD DOUBLE

ITEM	PART NO.	QTY	DESCRIPTION
1	00758772	1	Left Assembly
2	00758776	1	Plate
3	00755090	73	Chain
4	00757962	2	Rod
5	00758773	1	Right Assembly
6	00758777	1	Plate
7	00755090	30	Chain
8	00757963	2	Rod
9	02030700	13	Bolt
10	00001800	13	Nut
11	00002700	13	Flatwasher
12	00758195	1	Bar

# FRONT DEFLECTOR (STANDARD)

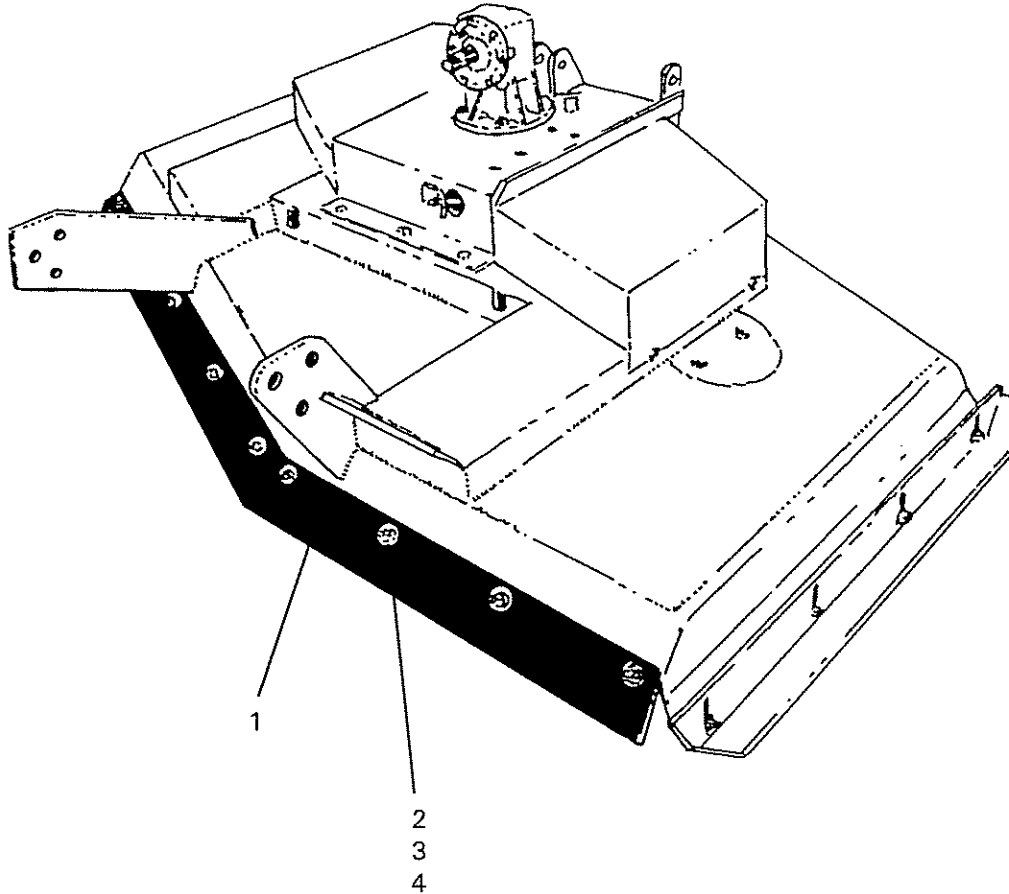

## FRONT DEFLECTOR

ITEM	PART NO.	QTY	DESCRIPTION
1	00758532	1	Debris Deflector Front
2	02030700	10	Bolt
3	00001800	10	Nut
4	00002700	10	Flatwasher

## REAR DEFLECTOR (STANDARD)

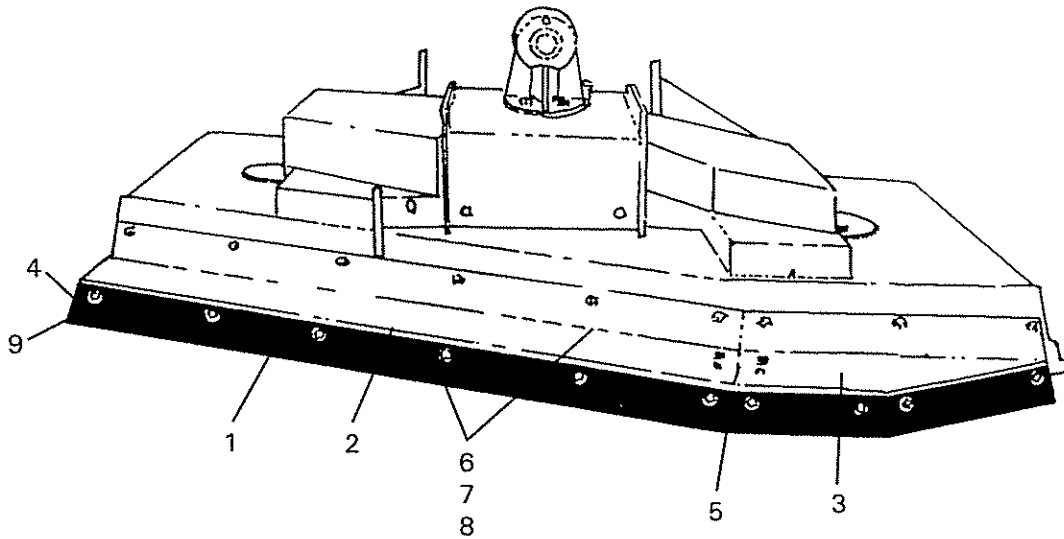

### REAR DEFLECTOR

ITEM	PART NO.	QTY	DESCRIPTION
1	00758531	1	Debris Deflector, Rear
2	00758533	1	Mount Plate, Left
3	00758534	1	Mount Plate, Right
4	00758535	1	Angle, Left
5	00758195	1	Tie Bar
6	02030700	35	Bolt
7	00001800	35	Locknut
8	00002700	35	Flatwasher
9	00758530	1	Debris Deflector, Rear (Left Hand Side)



# HYDRAULIC CYLINDER P/N 8727 (OPTIONAL)

NOTE: Seal to Install over Chamfer Side of New Style Piston. Note Position of Chamfer.

Old Style Piston Seal (Blue Seal)

NOTE: Seal Kit #8763 contains both Old & New Style Piston Seals. Use correct seals as required. New Piston #00760671 may be ordered to convert Old Style Cylinder to New Style Seal.

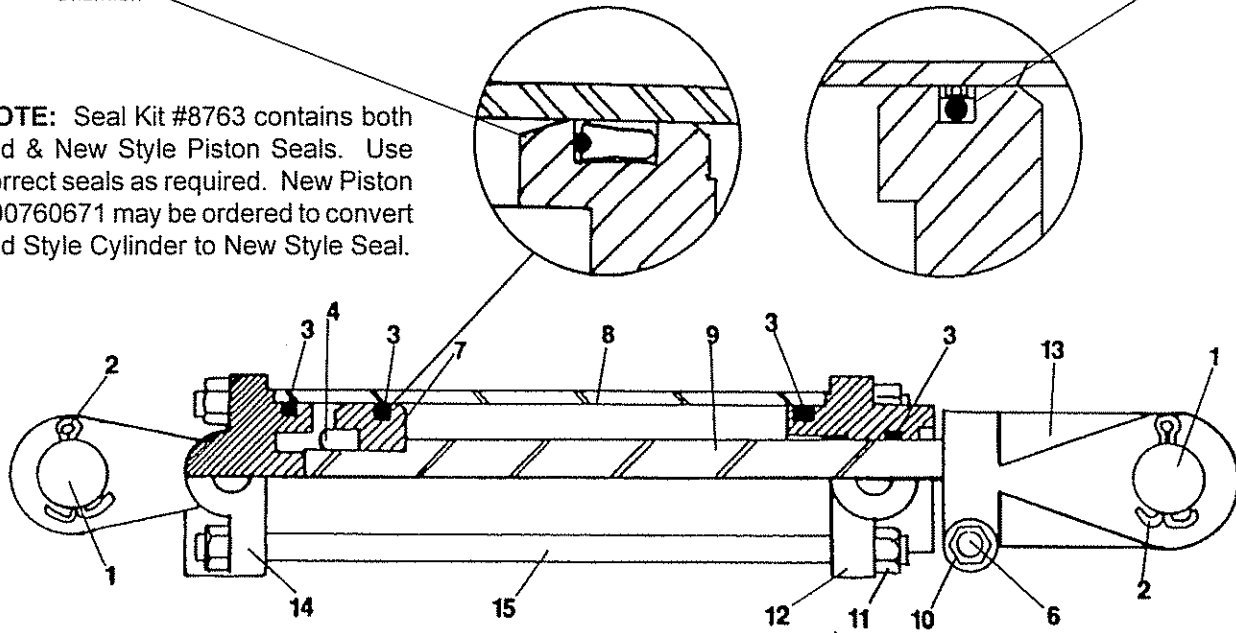

NEW STYLE - 2-1/2" BORE

ITEM	PART NO.	QTY	DESCRIPTION
	8727	1	Center Cylinder
1	8354	2	Pivot Pin
2	162012	2	Cotter Pin
3	00760199	2	Seal Kit
4	4675	1	Piston Nut
5*	7339	1	Breather Plug
6	4427	1	Bolt
7	00760671	1	Piston
8	8752	1	Tube
9	8753	1	Piston Rod
10	4378	1	Hex Nut
11	4690	8	Tie Rod Nut
12	8757	1	Head
13	8754	1	Outer Clevis
14	8755	1	Cap

# HYDRAULIC RELIEF ASSEMBLY

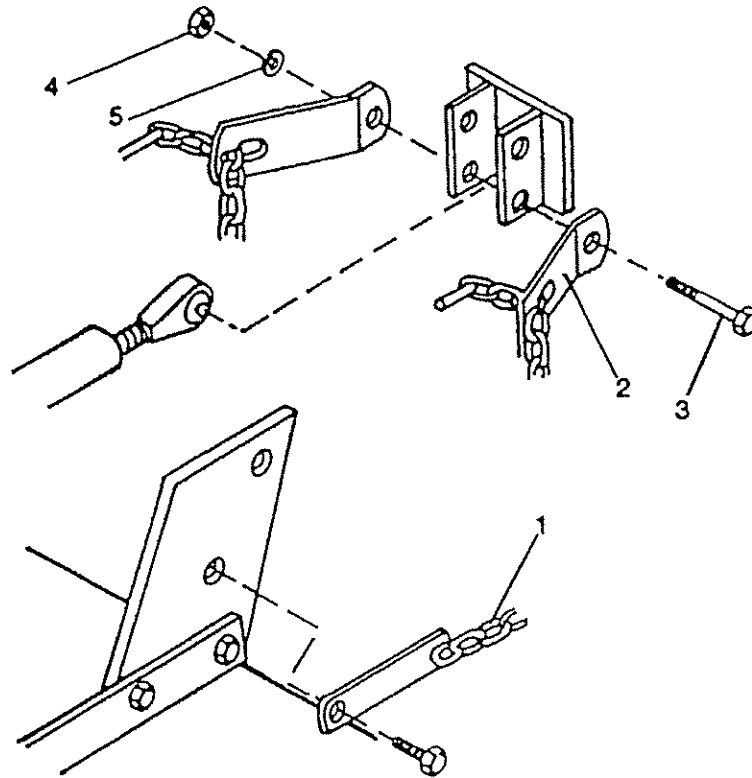

ITEM	PART NO.	QTY	DESCRIPTION
1	8709	2	Chain Assembly
2	8708	2	Bracket
3	8236	2	Bolt
4	4337	2	Nut
5	2372	2	Lockwasher

# WHEEL GROUP

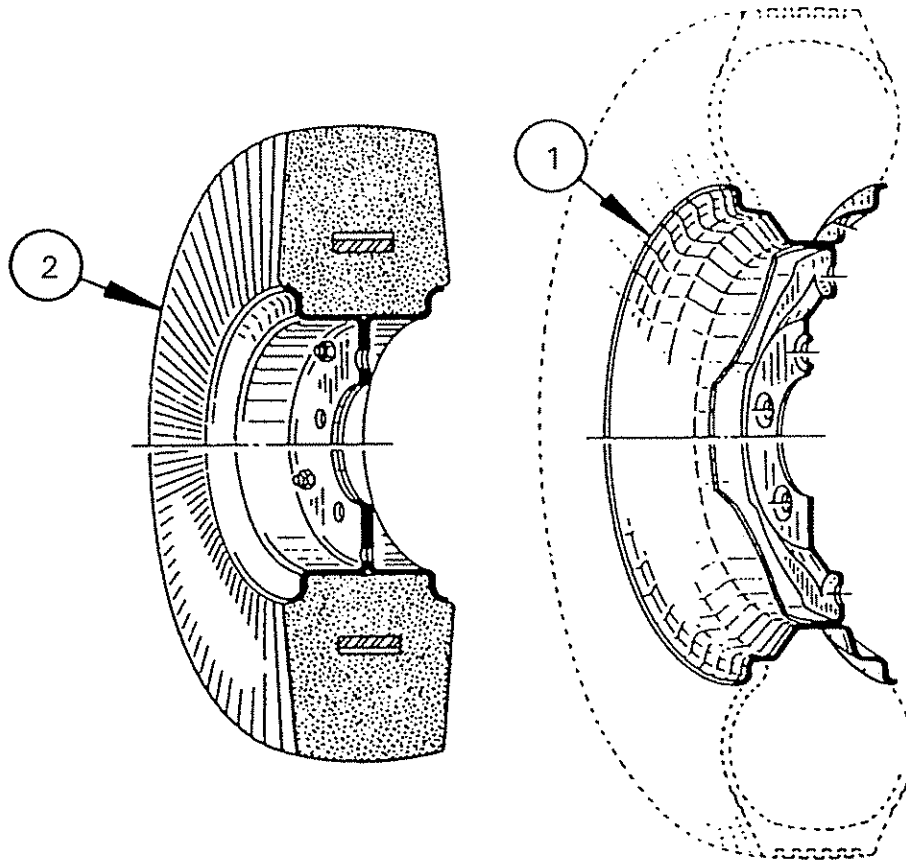

ITEM	PART NO.	QTY	DESCRIPTION
1	BPT-117	2	15" Wheel, (Standard Equipment)
	BPT-120	2	14" Wheel, (Optional Equipment)
2	B56-212	2	Laminated Puncture-Proof Tire & Wheel Assembly Consists 1-Ea. #56-212-1; #56-212-2 (Optional)
	56-212-1	2	Tire, Only (For #56-212)
	56-212-2	2	Wheel, (Bolted Assembly) Only, (For #56-212)

# WHEEL HUB ASSEMBLY

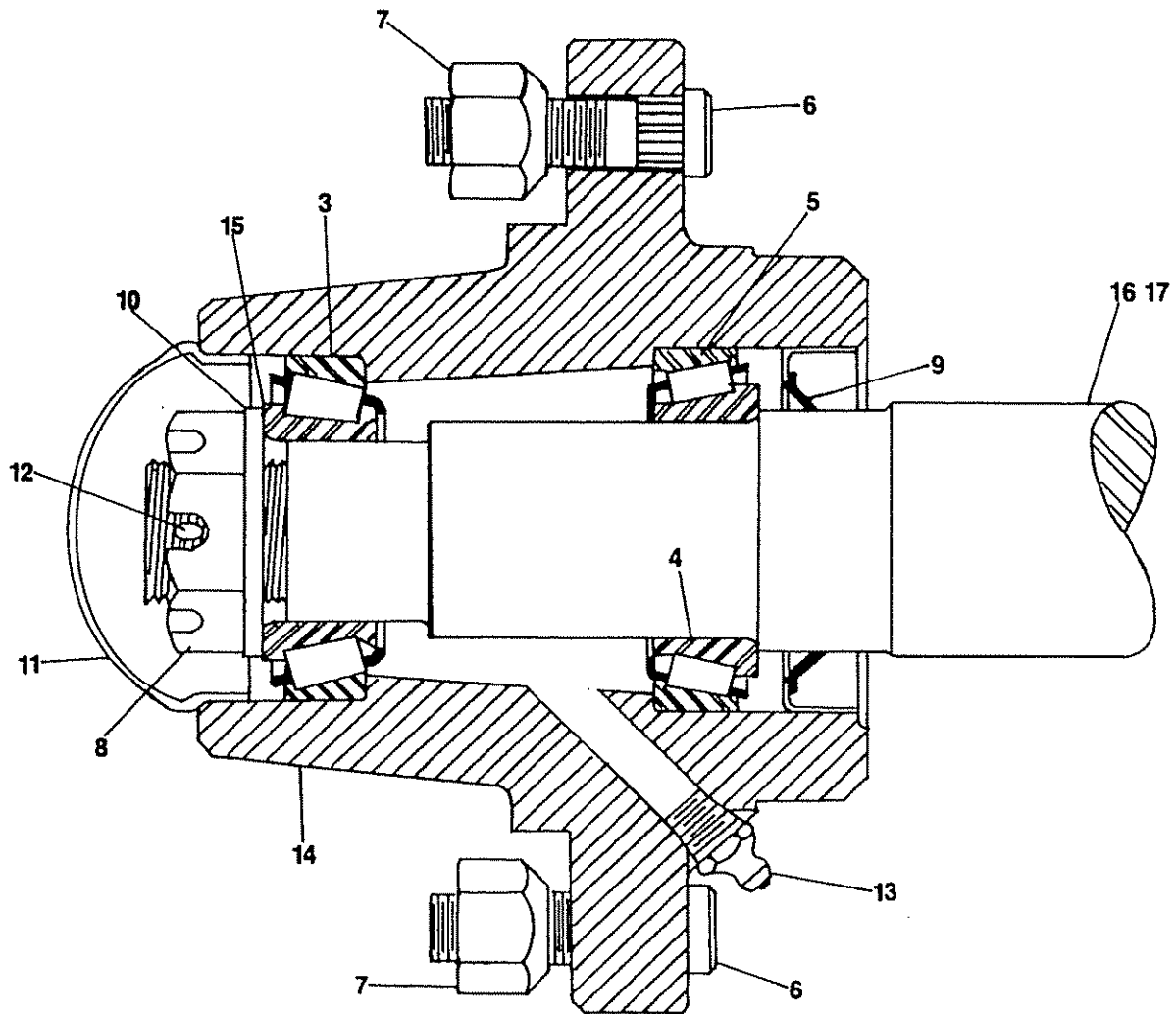

ITEM	PART NO.	QTY	DESCRIPTION
3	00756576	1	Bearing Cup(Outside)
4	00750434	1	Bearing Cone(Inside)
5	00756577	1	Bearing Cup(Inside)
6	00756488	5	Stud Bolt
7	00750614	5	Nut
8	00756490	1	Bearing Adjusting Nut
9	00756491	1	Seal
10	00756493	1	Washer
11	00756492	1	Dust Cap (2-7/16 dia. - 1"-14 Spindle Nut)
12	00000400	1	Cotter Pin
13	00003500	1	Grease Fitting
14	00756000	1	Wheel Hub
15	0371242102	1	Bearing Cone(Outside)
16	00756001	ref	Spindle, Single Wheel
	00756489	ref	Hub(w/Cups & Studs)
	00756528	ref	Wheel Hub Accessory Kit (inc. #4,6,7,8,9,10,11,12,& 15)
17	00756002	ref	Spindle, Dual Wheel

# TAIL WHEEL ASSEMBLY

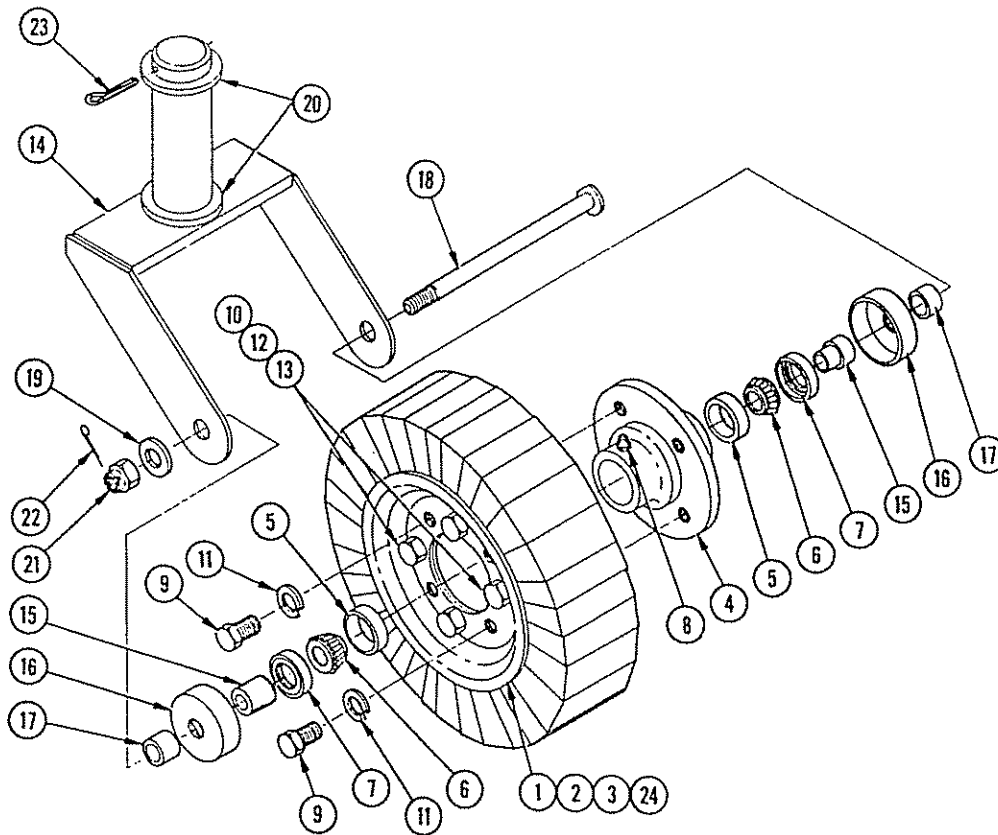

ITEM	PART NO.	QTY	DESCRIPTION
1	373024	1	Wheel Assembly
2	373024A	1	Tire
3	373024B	1	Wheel Only, 8" Dia. (Bolted Assy.)
4	373024C	1	Hub. (w/Bearing Cups & Grease Fitting)
5	373024G	2	Cup, Bearing
6	373024F	2	Cone, Bearing
7	373024E	2	Seal, Grease
8	17C1792B	1	Fitting, Grease (Threaded)
	00600000	1	Fitting, Grease (Drive in)
9	7A8208	4	Bolt
10	7A6166	4	Bolt
11	13800	4	Lockwasher
12	13600	4	Lockwasher
13	5b6160	4	Nut
14	0758520610	1	Fork Weldment
15	37302C2C	2	Sleeve, Shoulder
16	37302D2B	2	Cup, Dust
17	511016	2	Bushing, Spacer
18	37302D2A	1	Bolt, Spindle
19	15B1200	1	Washer
20	15B2400	2	Nut, Castle
21	5E12160	1	Nut, Castle
22	1621/2012	1	Pin, Cotter
23	164016	1	Cotter Pin
24	373024H	1	Tire & Wheel (Bolted Assy. Only, Less Hub)

**NOTE: 2 Assemblies required per machine.**

# BLADE BAR ASSEMBLY

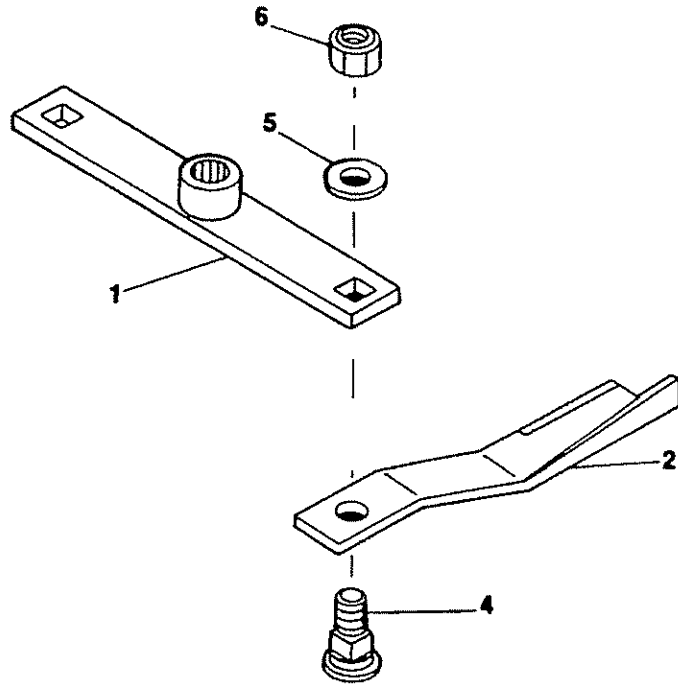

ITEM	PART NO.	QTY	DESCRIPTION
1	00758601	1	Blade Bar Weldment
2	00759495	1	Updraft Blade Set
4	8251	2	Blade Bolt - Special
5	9216	2	Washer
6	8201	2	Nut

# BLADE PAN ASSEMBLY

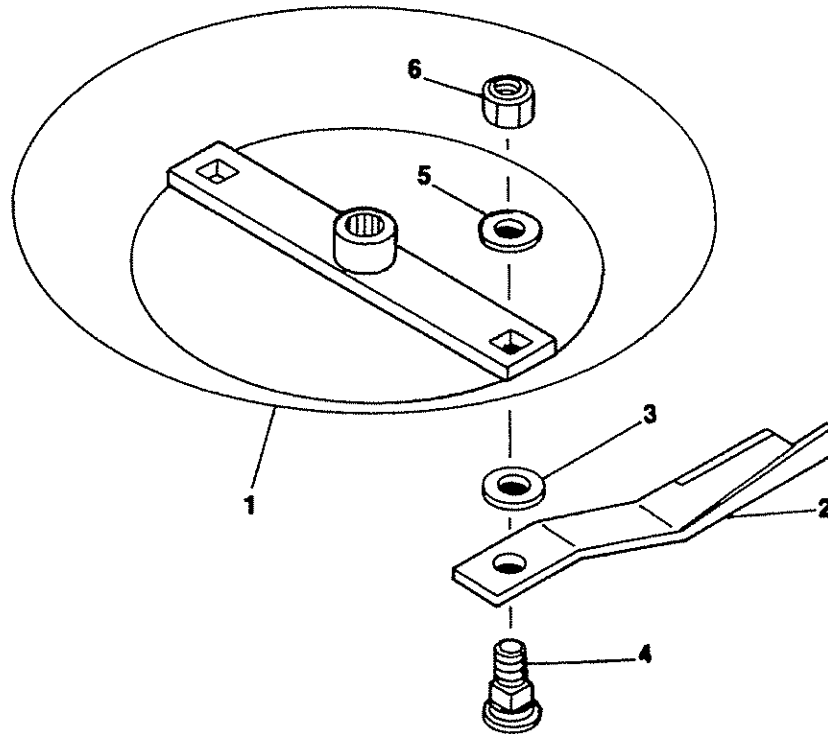

(Quantity shown for complete unit - 2 Dishpan Assemblies)

ITEM	PART NO.	QTY	DESCRIPTION
1	00758600	2	Dishpan Weldment
2	00759495	2	Updraft Blade Set
3	00758579	4	Washer
4	8227	4	Blade Bolt Kit w/Locknut
5	9216	4	Structural Washer
6	8201	4	Locknut

# SPRING SHOCK ASSEMBLY P/N 00758436

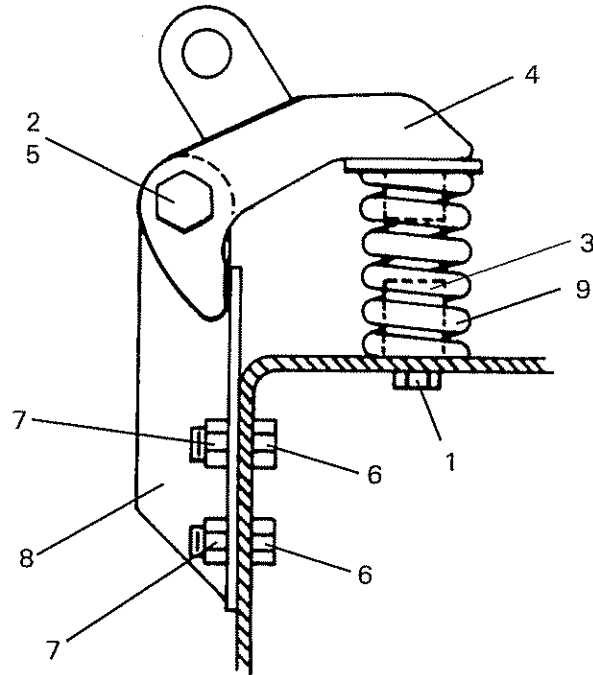

ITEM	PART NO.	QTY	DESCRIPTION
1	00037200	1	Nut
2	00609200	1	Bolt
3	00758187	1	Spring Stop Bar
4	00758188	1	Rocker Arm Weldment
5	02030300	1	Nut
6	02030700	4	Bolt
7	00001800	4	Nut
8	00758184	1	Cylinder Bracket
9	371063A	1	Spring



# HITCH EXTENSION KIT P/N 00763497

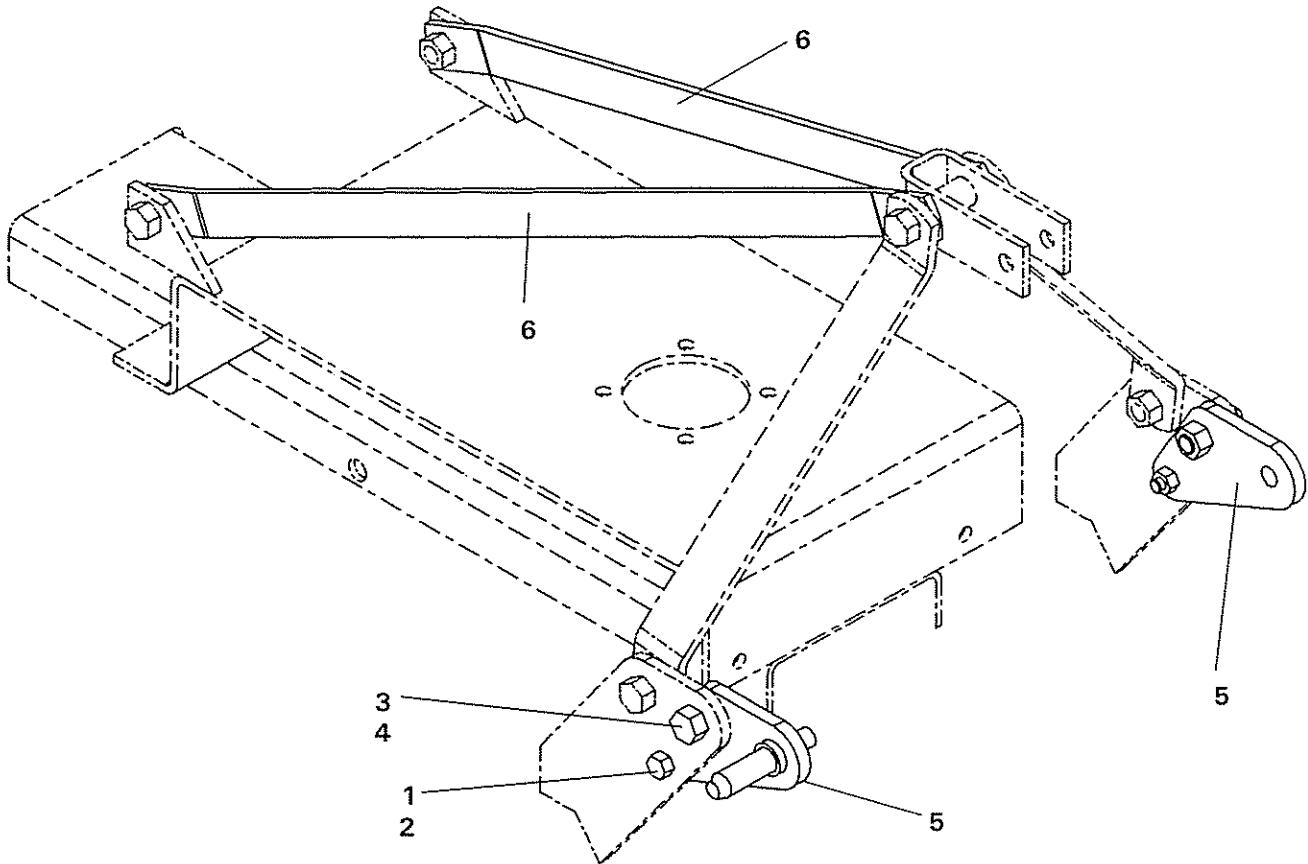

ITEM	PART NO.	QTY	DESCRIPTION
1	02845500	2	Bolt
2	00695100	2	Locknut
3	7A114916	2	Bolt
4	5JRC1490	2	Locknut
5	00761516	2	Plate - Lug Extension
6	00763500	2	Flat Rear Brace

# ALAMO

## LIMITED WARRANTY

### 1. LIMITED WARRANTIES

- 1.01. Alamo warrants for one year from the purchase date to the original non-commercial, governmental, or municipal purchaser ("Purchaser") and warrants for six months to the original commercial or industrial purchaser ("Purchaser") that the goods purchased are free from defects in material or workmanship.
- 1.02. Manufacturer will replace for the Purchaser any part or parts found, upon examination at one of its factories, to be defective under normal use and service due to defects in material or workmanship.
- 1.03. This warranty does not apply to any part of the goods which has been subjected to improper or abnormal use, negligence, alteration, modification, or accident, damaged due to lack of maintenance or use of wrong fuel, oil, or lubricants, or which has served its normal life. This warranty does not apply to any part of any internal combustion engine, or expendable items such as blades, shields, guards, or pneumatic tires except as specifically found in your Operator's Manual.
- 1.04. Except as provided herein, no employee, agent, Dealer, or other person is authorized to give any warranties of any nature on behalf of Manufacturer.

### 2. REMEDIES AND PROCEDURES.

- 2.01. This warranty is not effective unless the Purchaser returns the Registration and Warranty Form to Manufacturer within 30 days of purchase.
- 2.02. Purchaser claims must be made in writing to the Authorized Dealer ("Dealer") from whom Purchaser purchased the goods or an approved Authorized Dealer ("Dealer") within 30 days after Purchaser learns of the facts on which the claim is based.
- 2.03. Purchaser is responsible for returning the goods in question to the Dealer.
- 2.04. If after examining the goods and/or parts in question, Manufacturer finds them to be defective under normal use and service due to defects in material or workmanship, Manufacturer will:
  - (a) Repair or replace the defective goods or part(s).
  - (b) Reimburse Purchaser for the cost of the part(s) and reasonable labor charges (as determined by Manufacturer) if Purchaser paid for the repair and/or replacement prior to the final determination of applicability of the warranty by Manufacturer.
  - (c) The choice of remedy shall belong to Alamo.
- 2.05. Purchaser is responsible for any labor charges exceeding a reasonable amount as determined by Manufacturer and for returning the goods to the Dealer, whether or not the claim is approved. Purchaser is responsible for the transportation cost for the goods or part(s) from the Dealer to the designated factory.

### 3. LIMITATION OF LIABILITY.

- 3.01. MANUFACTURER DISCLAIMS ANY EXPRESS (EXCEPT AS SET FORTH HEREIN) AND IMPLIED WARRANTIES WITH RESPECT TO THE GOODS INCLUDING, BUT NOT LIMITED TO, MERCHANTABILITY AND FITNESS FOR A PARTICULAR PURPOSE.
- 3.02. MANUFACTURER MAKES NO WARRANTY AS TO THE DESIGN, CAPABILITY, CAPACITY, OR SUITABILITY FOR USE OF THE GOODS.
- 3.03. EXCEPT AS PROVIDED HEREIN, MANUFACTURER SHALL HAVE NO LIABILITY OR RESPONSIBILITY TO PURCHASER OR ANY OTHER PERSON OR ENTITY WITH RESPECT TO ANY LIABILITY, LOSS, OR DAMAGE CAUSED OR ALLEGED TO BE CAUSED DIRECTLY OR INDIRECTLY BY THE GOODS INCLUDING, BUT NOT LIMITED TO, ANY INDIRECT, SPECIAL, CONSEQUENTIAL, OR INCIDENTAL DAMAGES RESULTING FROM THE USE OR OPERATION OF THE GOODS OR ANY BREACH OF THIS WARRANTY. NOTWITHSTANDING THE ABOVE LIMITATIONS AND WARRANTIES, MANUFACTURER'S LIABILITY HEREUNDER FOR DAMAGES INCURRED BY PURCHASER OR OTHERS SHALL NOT EXCEED THE PRICE OF THE GOODS.
- 3.04. NO ACTION ARISING OUT OF ANY CLAIMED BREACH OF THIS WARRANTY OR TRANSACTIONS UNDER THIS WARRANTY MAY BE BROUGHT MORE THAN TWO (2) YEARS AFTER THE CAUSE OF ACTION HAS OCCURRED.

### 4. MISCELLANEOUS.

- 4.01. The laws of the State of Texas shall govern the construction of this agreement. Venue for any lawsuits shall be in Guadalupe County, Texas.
- 4.02. Manufacturer may waive compliance with any of the terms of this limited warranty, but no waiver of any terms shall be deemed to be a waiver of any other term.
- 4.03. If any provision of this limited warranty shall violate any applicable law and is held to be unenforceable, then the invalidity of such provision shall not invalidate any other provisions herein.

### KEEP FOR YOUR RECORDS

ATTENTION: Purchaser should fill in the blanks below for his reference when buying repair parts and/or for proper machine identification when applying for warranty.

Alamo Implement Model \_\_\_\_\_ Serial Number \_\_\_\_\_

Date Purchased \_\_\_\_\_ Dealer \_\_\_\_\_

ATTENTION:  
READ YOUR OPERATOR'S MANUAL

**ALAMO**  
An Alamo Group Company  
Post Office Drawer 549  
Seguin, Texas 78156  
210-379-1480





In addition to the standard Limited Warranty, Alamo Group provides one year (12 months), (6 months for Commercial/Industrial Users) Limited Warranty on the Driveline components provided that these components have been properly maintained and lubricated that and have not been subjected to abused or mis-use

In addition to the standard Limited Warranty shown on the preceding page, Alamo Group provides **A THREE YEAR LIMITED WARRANTY** on **GEARBOX** components\* provided that these components have been properly maintained and lubricated and have not been subjected to abuse or mis-use

\*One year for Seals (After on year, (six months for Industrial/Commercial use) seals are considered to be REPLACEMENT PARTS and replacement is the users' responsibility.)

\* Users' Gearboxes may be rebuilt by Alamo Group or replaced by new or rebuilt Gearboxes at the option of Alamo Group.

NOTE: "Failure to Maintain" also includes failure to adjust Slip Clutches correctly to provide proper protection for Driveline and Gearbox components.

NOTE: "Failure to Maintain" specifically includes running Gearboxes without proper lubrication and "burning up" the components.

## TO THE OWNER/OPERATOR/DEALER

To keep your implement running efficiently and safely, read your manual thoroughly and follow these directions and the Safety Messages in this Manual. The Table of Contents clearly identifies each section where you can easily find the information you need.

The OCCUPATIONAL SAFETY AND HEALTH ACT (1928.51 Subpart C) makes these minimum safety requirements of tractor operators:

### REQUIRED OF THE OWNER:

1. Provide a Roll-Over-Protective Structure that meets the requirements of this Standard; and
2. Provide Seatbelts that meet the requirements of this paragraph of this Standard and SAE J4C; and
3. Ensure that each employee uses such Seatbelt while the tractor is moving; and
4. Ensure that each employee tightens the Seatbelt sufficiently to confine the employee to the protected area provided by the ROPS.

### REQUIRED OF THE OPERATOR

1. Securely fasten seatbelt if the tractor has a ROPS.
2. Where possible, avoid operating the tractor near ditches, embankments, and holes.
3. Reduce speed when turning, crossing slopes, and on rough, slick, or muddy surfaces.
4. Stay off slopes too steep for safe operation.
5. Watch where you are going - especially at row ends, on roads, and around trees.
6. Do not permit others to ride.
7. Operate the tractor smoothly - no jerky turns, starts, or stops.
8. Hitch only to the drawbar and hitch points recommended by the tractor manufacturer.
9. When the tractor is stopped, set brakes securely and use park lock, if available.

- 
- Keep children away from danger all day, every day...**
  - Equip tractors with rollover protection (ROPS) and keep all machinery guards in place...**
  - Please work, drive, play and live each day with care and concern for your safety and that of your family and fellow citizens.**

