

ALAMO INDUSTRIAL WARRANTY REGISTRATION INFORMATION

Alamo Model	A M	Serial No.		Purchase Date	MONTH	DAY	YEAR	
					-	-		
Purchaser Last Name				First Name				M.I.
Street & No., RFD, Box, &/or Apt. No.								
City				State or Province			ZIP	
Dealer								
City				State or Province			ZIP	

• I have informed the Purchaser of this product of Warranty terms, provisions, and procedures that are applicable, reviewed the contents of the Operator's Manual including safety equipment, safe operation, and maintenance, reviewed the Safety Signs on implement (and tractor if possible), and Purchaser's responsibility to train his operators in safe operation.

• **MOWERS:** I have explained that Deflectors, Chain Guards, or Solid Skirts must be maintained in good repair and installed except in areas where persons, vehicles, livestock, or other property will not be endangered by thrown objects and where such safety equipment would prevent the mower's reasonable performance of its assigned task.

• **DRIVELINES:** Make certain that all drivelines, gearbox, and other shields are in good repair and fastened securely in place to prevent injuries from entanglement or thrown objects.

Dealer's Signature _____ **Date** _____

I have been instructed on the paragraphs above, received and have been instructed in the contents of the Operator's Manual including safety signs, safety equipment, safe operation, maintenance, and the potential hazards of unauthorized alteration or modification of the product. I have been informed of the warranty provisions and know that the warranty is not in effect until this form is received by Alamo Group.

I understand the Mower Guarding statements above and the potential hazards of operating without such guards. I understand that the operator is responsible for the safety of others in the area. I have examined the product and accept it as being complete and in satisfactory condition with all required guards.

CUSTOMER COPY

Purchaser's Signature _____ **Date** _____

PLEASE FILL OUT OWNER WARRANTY REGISTRATION INFORMATION ABOVE, SIGN, AND DROP LAST COPY IN ANY MAILBOX.

IMPORTANT!
**TO PLACE THIS WARRANTY IN EFFECT,
 THIS WARRANTY REGISTRATION MUST BE
 FILLED OUT, SIGNED, AND MAILED WITHIN 30
 DAYS OF DELIVERY DATE OF THIS MACHINE.
 DEALER AND PURCHASER MUST SIGN.**

**ATTENTION: ANY CLAIM SUBMITTED TO ALAMO INDUSTRIAL
 WILL BE REFUSED UNTIL COMPLETED, SIGNED
 WARRANTY REGISTRATION CARD IS ON FILE.**

ALAMO INDUSTRIAL WARRANTY REGISTRATION INFORMATION

Alamo Model Serial No. Purchase Date - -

Purchaser Last Name First Name M.I.

Street & No., RFD, Box, &/or Apt. No.

City State or Province ZIP

Dealer

City State or Province ZIP

- I have informed the Purchaser of this product of Warranty terms, provisions, and procedures that are applicable, reviewed the contents of the Operator's Manual including safety equipment, safe operation, and maintenance, reviewed the Safety Signs on implement (and tractor if possible), and Purchaser's responsibility to train his operators in safe operation.
- **MOWERS:** I have explained that Deflectors, Chain Guards, or Solid Skirts must be maintained in good repair and installed except in areas where persons, vehicles, livestock, or other property will not be endangered by thrown objects and where such safety equipment would prevent the mower's reasonable performance of its assigned task.
- **DRIVELINES:** Make certain that all drivelines, gearbox, and other shields are in good repair and fastened securely in place to prevent injuries from entanglement or thrown objects.
- **HYDRAULIC MACHINES:** I have explained the necessity of using clean hydraulic oil, changing filters as instructed, stopping leaks, damage caused by operating with over-heated oil, caring for hoses, using hoses of proper rating, the necessity of maintaining the specified operating pressure, and the potential hazard of oil's penetrating the skin.
- **BOOM-TYPE or FOLDING-TYPE MOWERS:** I have explained that it is not possible to guard against thrown objects when the head is lifted off ground and that operator is responsible to watch out for persons in the area. I have explained that the lifted mower head or boom can contact overhead obstructions with damage to cables and telephone lines and possible injury. I have explained that the extended head or boom or retracted boom can contact power lines with resulting electrocution injury or death and that operator is responsible for keeping clear of such hazards.

Dealer's Signature _____ Date _____

I have been instructed on the paragraphs above, received and have been instructed in the contents of the Operator's Manual including safety signs, safety equipment, safe operation, maintenance, and the potential hazards of unauthorized alteration or modification of the product. I have been informed of the warranty provisions and know that the warranty is not in effect until this form is received by Alamo Group.

I understand the Mower Guarding statements above and the potential hazards of operating without such guards. I understand that the operator is responsible for the safety of others in the area. I have examined the product and accept it as being complete and in satisfactory condition with all required guards.

Purchaser's Signature _____ Date _____

PLEASE FILL OUT OWNER WARRANTY REGISTRATION INFORMATION ABOVE, SIGN, AND DROP THIS CARD IN ANY MAILBOX.

IMPORTANT!

TO PLACE THIS WARRANTY IN EFFECT, THIS WARRANTY REGISTRATION MUST BE FILLED OUT, SIGNED, AND MAILED WITHIN 30 DAYS OF DELIVERY DATE OF THIS MACHINE. DEALER AND PURCHASER MUST SIGN.

ATTENTION: ANY CLAIM SUBMITTED TO ALAMO INDUSTRIAL WILL BE REFUSED UNTIL COMPLETED, SIGNED WARRANTY REGISTRATION CARD IS ON FILE.



ALAMO INDUSTRIAL

PO BOX 549
SEGUIN TX 78156-9967

Tear off & discard this part. Mail the card above.

Alamo Industrial
PO BOX 549
Seguin, Texas 78156-9967
210-372-3551



Alamo Industrial provides a full line of field tested & proven lift-type, pull-type, boom-mounted, offset-mounted, & semi-mounted rotary, flail, & sickle bar mowers; tractor-mounted, three-section flail mowers; self-powered rotary & flail mowers; and shredders.



AM5000

Rotary Mower

Rev 03-13

P/N 00767094

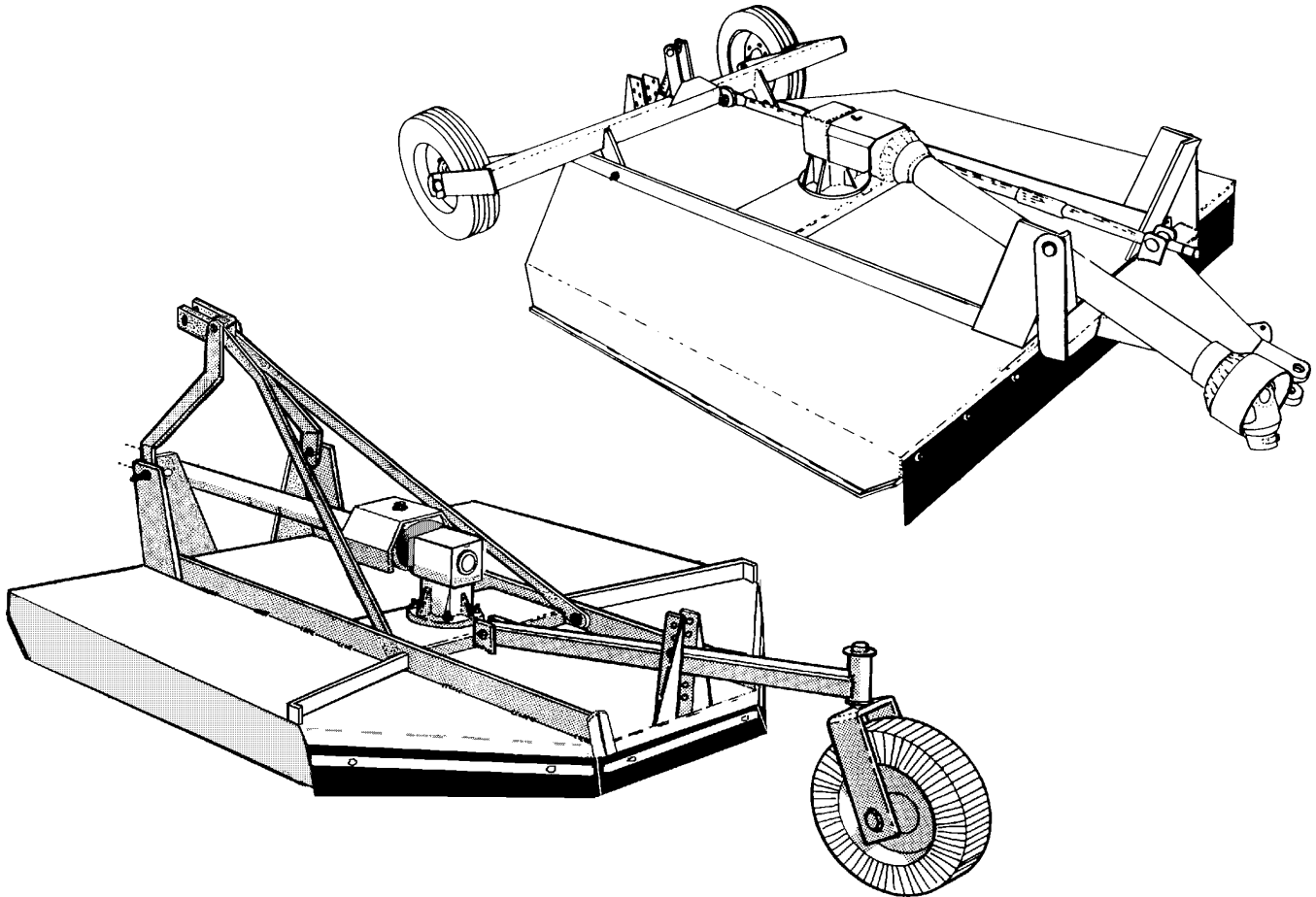

OPERATOR'S MANUAL with PARTS LISTING

ALAMO INDUSTRIAL

1502 E. Walnut
Seguin, Texas 78155
830-372-9595



BUILT SHARPER®

An Alamo Group Company

© 2013 Alamo Group Inc.

TO THE OWNER/OPERATOR/DEALER

All implements with moving parts are potentially hazardous. There is no substitute for a cautious, safe-minded operator who recognizes the potential hazards and follows reasonable safety practices. The manufacturer has designed this implement to be used with all its safety equipment properly attached to minimize the chance of accidents.

BEFORE YOU START!! Read the safety messages on the implement and shown in your manual.
Observe the rules of safety and common sense!



FAILING TO FOLLOW SAFETY MESSAGES AND OPERATING INSTRUCTIONS CAN CAUSE SERIOUS BODILY INJURY OR EVEN DEATH TO OPERATOR AND OTHERS IN THE AREA

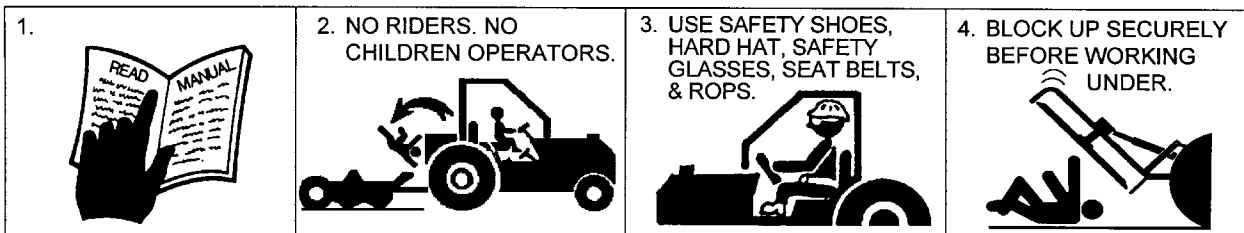

1. Study and understand Operator's Manuals, Safety Signs, and Instructional Decals for tractor and implement to prevent misuse, abuse, and accidents. Practice before operating in a confined area or near passersby.
 - Learn how to stop engine suddenly in an emergency. Be alert for passersby and especially children.
2. Allow no children on or near implement or tractor. Allow no riders on tractor or implement. Falling off may cause serious injury or death from being run over by tractor or cutter or contact with rotating blades.
3. Operate only with tractor having Roll-Over Protective Structure (ROPS) and with seatbelt fastened securely and snugly to prevent injury and possible death from falling off or tractor overturn. Personal Protective Equipment such as Hard Hat Safety Glasses, Safety shoes, and Ear Plugs are recommended.
4. Block up or support raised machine and all lifted components securely before putting hands or feet under or working underneath any lifted components to prevent crushing injury or death from sudden dropping or inadvertent operation of controls. Make certain area is clear before lowering or folding.
5. Before transporting, put Lift Lever in detent or full-lift position. Install *Cylinder Stops as Transport Blocks securely or pull-type and folding implements. Slow down when turning and on hillsides.
 - Attach **Safety Chain to cutter and towing unit securely. See Operator's Manual.
6. Make certain that SMV sign, Warning Lights, and Reflectors are clearly visible. Follow local traffic codes.
7. Never operate with Cutting Head raised if passersby, bystanders, or traffic are in the area to reduce possibility of injury or death from objects thrown by Blades under Guards or cutter structure.
8. Before dismounting, secure implement in transport position or lower to ground.
 - Put tractor in park or set brake, disengage PTO, stop engine, and remove key, and wait until noise of rotation has ceased to prevent entanglement in rotating parts which can cause injury or death.
 - Never mount or dismount a moving vehicle. Crushing from runover may cause injury or death.

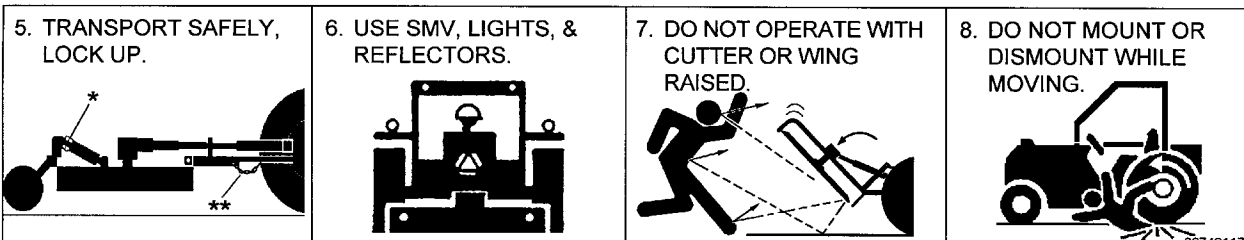

WARRANTY INFORMATION:

Read and understand the complete Warranty Statement found in this Manual. Fill out the Warranty Registration Form in full and return it within 30 Days. Make certain the Serial Number of the Machine is recorded on the Warranty Card and on the Warranty Form that you retain. The use of "will-fit" parts will void your warranty and can cause catastrophic failure with possible injury or death.

TABLE OF CONTENTS

SAFETY SECTION

Safety Information	1-2
Safety Decal Location	1-6

INTRODUCTION SECTION

Introduction	2-2
--------------------	-----

ASSEMBLY SECTION

Shear Pin installation	3-2
Shield Assembly	3-2
A-Frame Installation	3-3
Tail Wheel Installation	3-3
Hydraulic Relief	3-4
Rear Axle Assembly	3-5
Tongue Assembly	3-5
Chain Guard Attachments	3-6

OPERATION SECTION

Mower Preparation	4-2
Tractor Preparation	4-3
Attaching Mower to Tractor	4-3
Parking Jack	4-5
Safety Chains	4-5
Cutting Height Adjustment	4-6
Starting & Stopping	4-7
Cutting Speed	4-7
Cutting Tips	4-7
Detaching & Storing	4-8
Driveline Length Check	4-8
Rough Terrain Operation	4-9
Transporting	4-10
Offset Adapter	4-11
Trouble Shooting Guide	4-12

MAINTENANCE SECTION

Lubrication	5-2
Gearbox	5-3
Driveline	5-4
Blade Servicing	5-5
Blade Sharpening	5-5
Blade Removal	5-6
Slip Clutch Service	5-7
Storage	5-8
Torque Chart	5-8
Gearbox Service	5-9

PART SECTION

Parts Ordering Guide	6-2
Parts Table of Contents	6-3

SAFETY

DANGER!



There are obvious and hidden potential hazards in the operation of this mower. **REMEMBER!** This machine is often operated in rough terrain conditions and in heavy weeds. The Blades of this mower can throw objects for a great distance at very high speeds. Serious injury or even death may occur unless care is taken to insure the safety of the operator, bystanders, or passersby in the area.

Included here is a list of Safety Messages which should be followed. Serious injury or death may occur unless care is taken to follow these Safety Messages and use good common sense in avoiding hazards.

Equipment should be operated only by those who are responsible and instructed to do so.

¡PELIGRO!



Si no lee Ingles, pida ayuda a alguien que si lo lea para que le traduzca las medidas de seguridad.

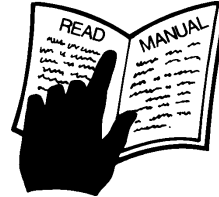

¡ LEA EL INSTRUCTIVO!

DANGER!



Read this manual carefully to acquaint yourself with the Rotary Mower. Working with unfamiliar equipment can lead to accidents.

DANGER!



Rotary Mowers are capable under some conditions of throwing objects for great distances (100 yards or more), and causing objects to inflict serious injury or death. Follow safety messages carefully.

STOP MOWING IF PASSERSBY ARE WITHIN 100 YARDS UNLESS:

Front and Rear Deflectors, or Chain Guards, or Bands are installed and in good, workable condition.
-Mower sections are running close to and parallel to the ground without exposed Blades;
-Passersby are outside the existing thrown-object zone;
-All areas have been thoroughly inspected and all foreign material such as rocks, cans, glass, and general debris has been removed.

NOTE: Where there are grass and weeds high enough to hide debris that could be struck by the blades, the area should be inspected and large debris removed, mowed at an intermediate height, inspected closely with any remaining debris being removed, and mowed again at desired final height. (This will also reduce power required, reduce wear and tear on the Mower drivetrain, spread cut material better, eliminate streaking, and make the final cut more uniform.)

WARNING!



The Chain Guards, Bands, Flaps, Driveline Shields, and Gearbox Shields should be used and maintained in good working conditions. They should be inspected carefully at least daily for missing or broken cable, chain links, shields, or guards. Missing, broken, or worn items must be replaced at once to reduce the possibility of injury from thrown objects or entanglement.

DANGER!



Extreme care should be taken when operating near loose objects such as gravel, rocks, wire, and other debris. Foreign objects should be removed from the site or avoided to prevent machine damage and/or bodily injury or even death.

WARNING!



Do not let the Blades turn when the Mower Deck is raised for turning. This exposes the Cutting Blades which creates a potentially serious hazard and could cause serious injury or even death by objects thrown from the Blades.

SAFETY

WARNING! Do not modify or alter or permit anyone to modify or alter this equipment or any of its components or any equipment function without first consulting your Equipment Dealer.



WARNING! The operator and all support personnel should wear hard hats, safety shoes, and safety glasses at all times for protection from injury by falling objects and items thrown by the machine.



WARNING! Before leaving the tractor seat, always engage the brake and/or set the tractor transmission in parking gear. Disengage the PTO, stop the engine, remove the key, and wait for all moving parts to stop. Place the tractor shift lever into a low range or parking gear to prevent the tractor from rolling. Never mount or dismount a moving tractor. Operate the tractor controls from the tractor seat only.



WARNING! Many varied objects, such as wire, cable, rope, or chains, can become entangled in the operating parts of the mower head. These items could then swing outside the housing at greater velocities than the blades. Such a situation is extremely hazardous. Inspect the cutting area for such objects before mowing. Remove any like object from the site. Never allow the cutting blades to contact such items.



DANGER! Be particularly careful in transport. Turn curves or go up hills only at a low speed and at a gradual steering angle. Make certain that at least 20% of the tractor's weight is on the front wheels to maintain safe steering. Slow down on rough or uneven surfaces.



WARNING! Make certain that the "Slow Moving Vehicle" (SMV) sign is installed in such a way as to be clearly visible and legible. Use flashing warning lights and follow all local traffic regulations.



WARNING! Periodically inspect all moving parts for wear and replace with authorized service parts if an excessive amount of wear is present.



WARNING! Look for loose fasteners, worn or broken parts, and leaky or loose fittings. Make sure all pins have cotter pins and washers. Serious injury may occur from not maintaining this machine in good working order.



DANGER! Do not mount or dismount the tractor while the tractor is mowing. Mount or dismount the tractor only when it is completely stopped.



DANGER! Never leave the mower in the raised transport position. Mower could fall causing injury to anyone who might inadvertently be under mower.



SAFETY

DANGER!

Never clean or adjust PTO-driven equipment with the tractor engine running.



WARNING!

Never allow riders on either tractor or mower. Falling off can kill.



DANGER!

Operate the mower only with a tractor equipped with an approved roll-over-protective system (ROPS). Always wear seat belts. Serious injury or even death could result from falling off the tractor--particularly during a turnover when the operator could be pinned under the ROPS for the Tractor.



DANGER!

Never allow children to operate or ride on the tractor or mower.



DANGER!

Never work under the Mower Deck, the framework, or any lifted component unless the mower is securely supported or blocked up to prevent sudden or inadvertent falling which could cause serious injury or even death.



WARNING!

Never operate the tractor and mower until you have read and completely understand this manual, the Tractor Operator's Manual, and each of the Safety Messages found on the tractor and mower.



WARNING!

Always maintain the safety decals in good readable condition. If a decal becomes torn, painted over, or otherwise illegible, order replacement decals immediately.



DANGER!

Make sure the PTO shield is installed when using PTO-driven equipment, and always replace the PTO shield if damaged.



WARNING!

Do not turn sharp enough to get severe "knocking" or vibration in the Driveline which will cause accelerated wear and breakage of drive train components which may cause injury from the separated Driveline sections.



SAFETY

CAUTION!



PROLONGED EXPOSURE TO LOUD NOISE MAY CAUSE PERMANENT HEARING LOSS!

Tractors with or without Mowers attached can often be noisy enough to cause permanent, partial hearing loss. We recommend that you wear hearing protection on a full-time basis if the noise in the Operator's position exceeds 80db. Noise over 85db on a long-term basis can cause severe hearing loss. Noise over 90db adjacent to the Operator over a long-term basis may cause permanent, total hearing loss. Note: Hearing loss from loud noise [from tractors, chain saws, radios, and other such sources close to the ear] is cumulative over a lifetime without hope of natural recovery.

In addition to the design and configuration of this implement, including Safety Signs and Safety Equipment, hazard control and accident prevention are dependent upon the awareness, concern, prudence, and proper training of personnel involved in the operation, transport, maintenance, and storage of the machine. Refer also to Safety Messages and operation instruction in each of the appropriate sections of the Tractor and Mower Manuals. Pay close attention to the Safety Signs affixed to the Tractor and Mower.

SAFETY DECAL LOCATION

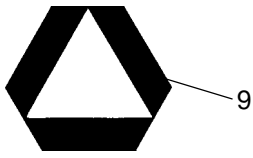

AM5000 LIFT TYPE

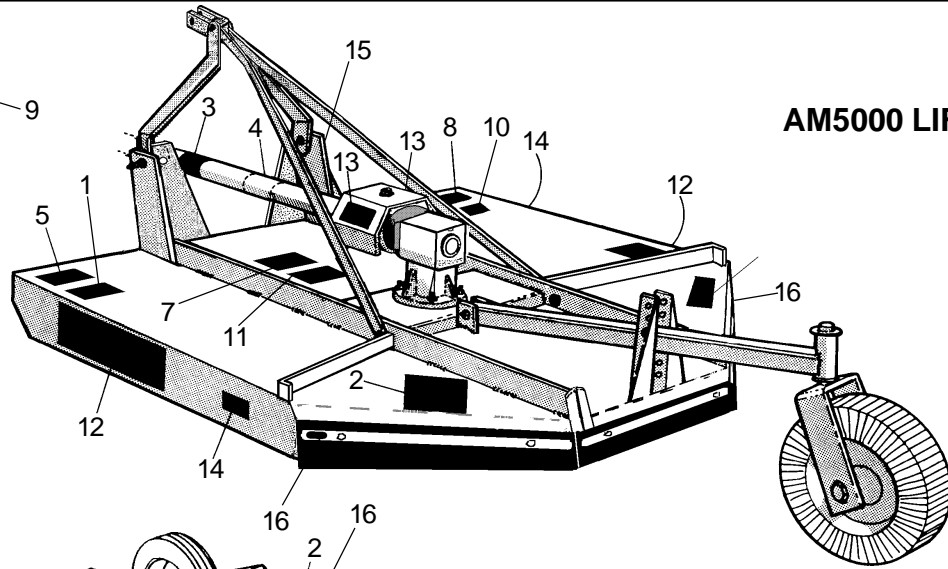

AM5000 PULL TYPE

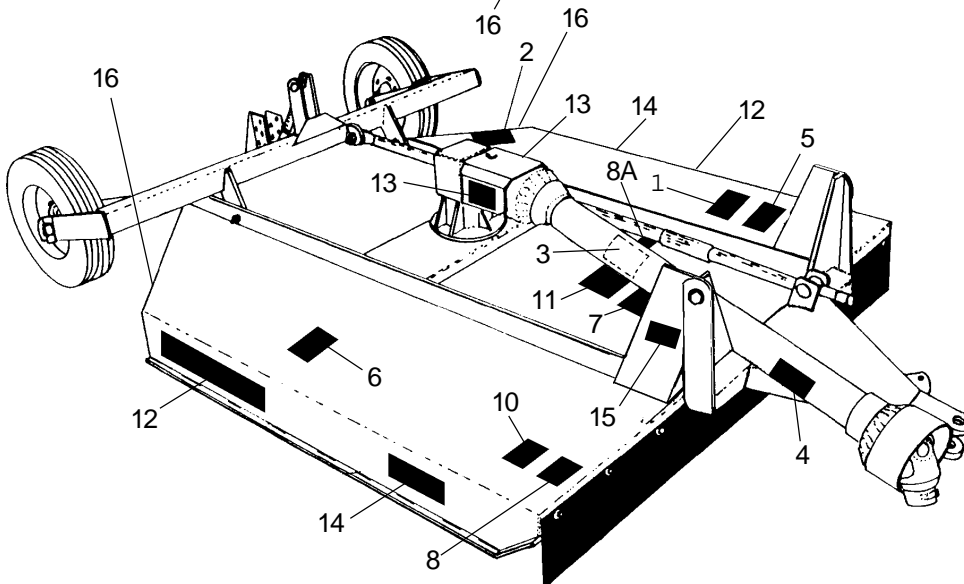

ITEM	PART NO.	QTY	LEVEL	DESCRIPTION
1	00725746	1	PELIGRO!	Get Safety Translated
2	00749117	1	DANGER!	Multiple Hazard
3	00756004	((1))	DANGER!	Driveline Shield Missing
4	00756005	((1))	DANGER!	Rotating Driveline
5	00769736	1	WARNING!	Use/Repair Shields & Guards
6	00769737	1	DANGER!	Blades/Thrown Objects
7	00756494	1	DANGER!	Driveline hazards
8	02925100	1	CAUTION!	Genuine Parts, Alamo Rotary
8A	00773723	1	PELIGRO!	Rotating Driveline Translation
9	03200347	*	REFLECT	SMV Emblem
10	00763977	1	INSTRUCT	Notice to Owner
11	D103	1	INSTRUCT	540 RPM Operation
12	00757139	2	LOGO	ALAMO by TK (5.5 x 19.5)
13	02960766	2	LOGO	ALAMO (4 x 5)
14	00767095	2	NAME	AM5000 Name Decal
15	NFS	1	SRL PLT	Serial Plate
16	2738332	2	REFLECT	Red Reflector

* Furnished by the Tractor Manufacturer
 (()) Installed by D/L Manufacturer

DECALS

⚠ WARNING

**OPERATE THIS MACHINE AT
540 RPM
TRACTOR PTO SPEED ONLY**

Overspeeding PTO may cause component failure with resulting injury.

D103

11 - D103



⚠ DANGER

1. MAKE CERTAIN DRIVELINES ARE OF THE CORRECT LENGTH AND SECURELY ATTACHED. DRIVELINE SEPARATION AND/OR PTO STUB SHAFT FAILURE CAN CAUSE INJURY OR DEATH. (See Operator's Manual for procedure.)

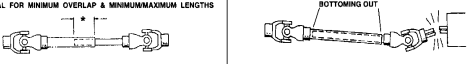
* SEE MANUAL FOR MINIMUM OVERLAP & MINIMUM/MAXIMUM LENGTHS



2. MAKE CERTAIN THAT DRIVELINE SHIELDS ARE INSTALLED CORRECTLY AND TURN FREELY TO PREVENT INJURY OR DEATH FROM ENTANGLEMENT

3. MAKE CERTAIN THAT DRIVELINE IS INSTALLED CORRECTLY ON TRACTOR PTO SHAFT. MOVE YOKE BACK AND FORTH UNTIL LOCKING COLLAR CLICKS FORWARD AND LOCKS YOKE IN PLACE

4. 540 PTO RPM UNLESS SPECIFICALLY MARKED OTHERWISE.

00756494

7 - 00756494

NOTICE TO OWNER

An OPERATOR'S MANUAL (with Repair Parts Listing) and a WARRANTY REGISTRATION CARD were attached to this implement during final inspection at the factory. If they were not attached at the time of purchase, please contact your selling dealer at once.

1. Read and understand Manual before operating the implement.
2. Complete, sign, and mail the Warranty Registration Card in today.

00763977

10 - 00763977



13 - 02960766

⚠ PELIGRO

Si No Lee Ingles, Pida Ayuda a Alguien Que Si Lo Lea Para Que le Traduzca las Medidas de Seguridad.

LEA EL INSTRUCTIVO



00725746

1 - 00725746

⚠ DANGER



**ROTATING DRIVELINE-
CONTACT CAN CAUSE DEATH
KEEP AWAY!**

DO NOT OPERATE WITHOUT-

- All driveline guards, tractor and equipment shields in place
- Drivelines securely attached at both ends
- Driveline guards that turn freely on driveline

00756005

4 - 00756005

⚠ DANGER



**GUARD MISSING
DO NOT OPERATE**

00756004

⚠ DANGER



**GUARD MISSING
DO NOT OPERATE**

00756004

⚠ DANGER

3 - 00756004

⚠ CAUTION

For your safety and to guarantee optimum product reliability, always use genuine ALAMO replacement parts. The use of inferior "will-fit" parts will void warranty of your ALAMO implement and may cause premature or catastrophic failure which can result in serious injury or death. If you have any questions concerning the repair parts you are using, contact ALAMO, POB 549, Seguin, TX 78156-0549

02925100

8 - 02925100

AM5000

14 - 00767095

2 - 00749117 - Not Shown
(See Inside Front Cover of Manual)

15 - Serial Plate

DECALS

WARNING

FAILURE TO USE AND MAINTAIN SHIELDS AND DEFLECTORS IN GOOD CONDITION MAY LEAD TO INJURY OR DEATH FROM ENTANGLEMENT WITH ROTATING PARTS, BEING HIT BY OBJECTS THROWN WITH GREAT FORCE BY BLADES, OR BY BLADE CONTACT.

- Always replace Guards which have been removed for maintenance. Never operate with Guards missing or broken.

- Chain Guards, Gearbox & Driveline Shields, Rubber-Fabric Deflectors, and Solid Band Enclosures are subject to wear and lost or broken parts and must be repaired or replaced as soon as damage is found.

- Safety Shielding must be installed and in good condition to reduce the possibility of thrown objects any time this machine is operated in any area where thrown objects could cause property damage or bodily injury.

ROTARY 00769736

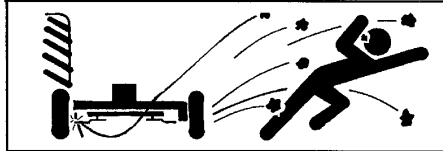
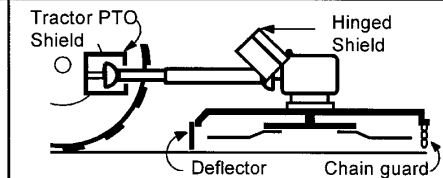

5-00769736

DANGER

THROWN OBJECTS

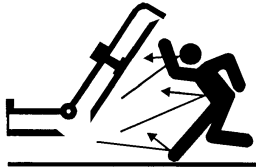

CUTTING BLADES

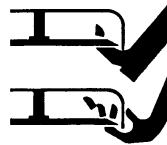

KEEP AWAY - ROTATING BLADES

BEING HIT BY THROWN OBJECTS OR CONTACTING ROTATING BLADES CAN CAUSE INJURY OR DEATH.

- Stop mowing if passersby enter the area of thrown objects (See Operator's Manual).
- Do not operate with Mower or Wing raised off the ground. (See Operator's Manual).
- Operate only if all Guards-Deflectors are in place and in good condition.

00769737

6-00769737

ALAMU INDUSTRIAL

12-00757139

INTRODUCTION

This Rotary Mower is designed with care and built with quality materials by skilled workers. Proper assembly, maintenance, and operating practices, as described in this manual, will help the owner/operator get years of satisfactory service from the machine.

The purpose of this manual is to familiarize, instruct, and train. The Assembly Section instructs the owner/operator in the correct assembly of the Mower using standard and optional equipment. The Parts Listing section is designed to familiarize the owner/operator with replaceable parts on the Mower. This section provides exploded assembly drawings of each mower component illustrating each piece and the corresponding part number.

Careful use and timely service saves extensive repairs and costly downtime losses. The Operation and Maintenance Sections of the manual train the owner/operator how to work the Mower correctly and attend to appropriate maintenance. The Trouble Shooting Guide helps diagnose difficulties with mower and offers solution to the problems.

Safety is of primary importance to the owner/operator and to the manufacturer. The first section of this manual includes a list of Safety Messages, that, if followed, will help protect the operator and bystanders from injury or death. Many of the Safety Messages will be repeated throughout the manual. The owner/operator/dealer should know these Safety Messages before assembly and be aware of the hazards of operating this mower during assembly, use, and maintenance. The Safety Alert Symbol combined with a Signal Word, as seen below, is intended to warn the owner/operator of impending hazards and the degree of possible injury faced when operating this machine.

CAUTION The lowest level of Safety Message; warns of possible minor injury. Decals located on the Mower with this Signal Word are Black and Yellow.



WARNING Serious injury or possible death! Decals are Black and Orange.



DANGER Imminent death/critical injury. Decals are Red and White.



INTRODUCTION

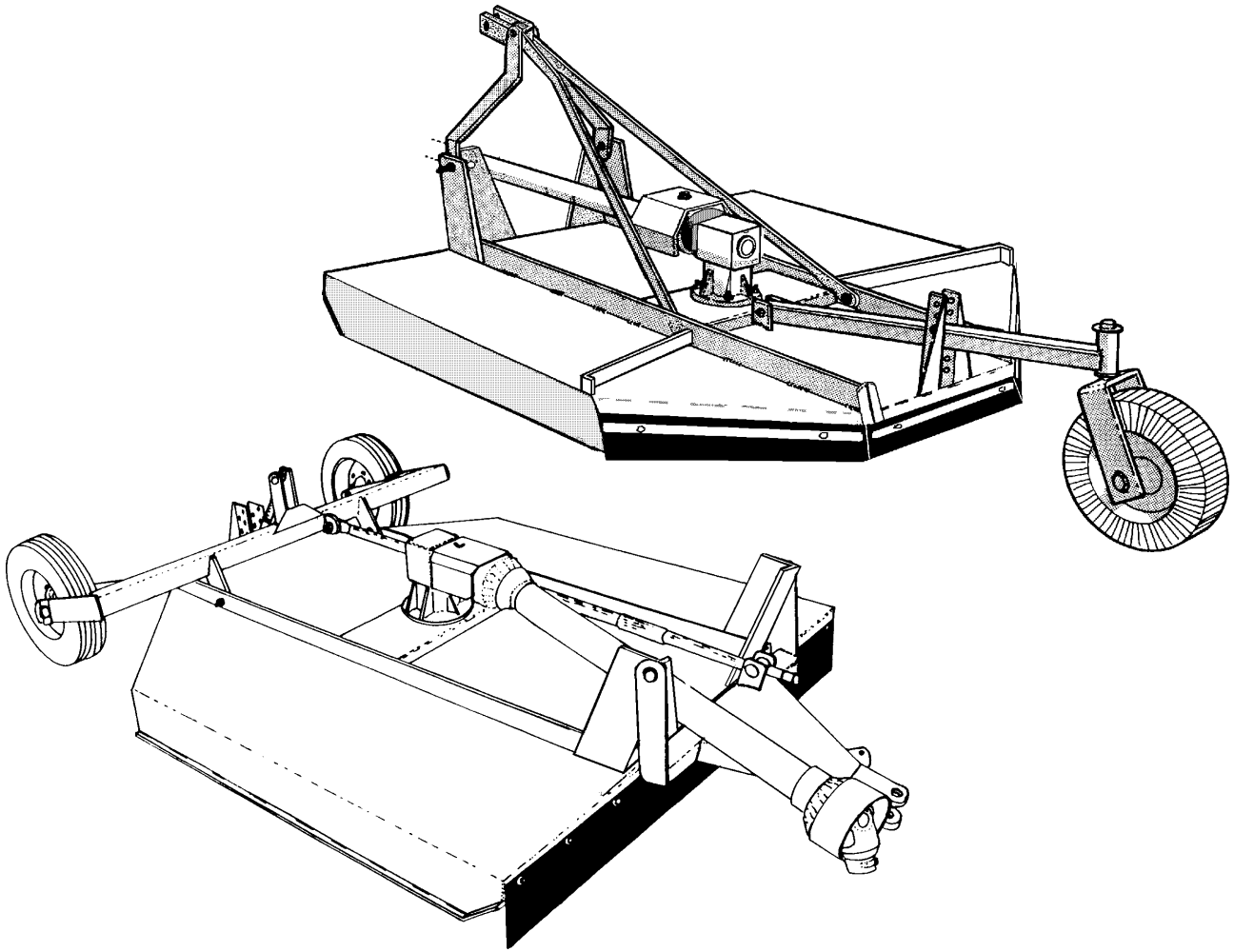

Your ALAMO AM5000 mower is designed for light-duty cutting such as pasture mowing, weed, and grass control. With a reasonable amount of preventive maintenance, your Mower will provide years of dependable service.

DANGER



For Non-Agricultural use, OSHA, ASAE, SAE, and ANSI standards require the use of Chain Guards, Deflectors, or Solid Skirts at all times. The Mower manufacturer strongly recommends the use of Chain Guards or Solid Skirts for Agricultural purposes as well, to reduce the risk of property damage, serious bodily injury, or even death from objects thrown out by or from contact with the Cutting Blades.

WARNING



At least 20% of the tractor's weight must be on the front tires with the Mower lifted to provide adequate traction for safe steering under good conditions. Slow down on hills, rough terrain, and curves.

Front and rear and left and right are determined by the normal direction of travel, the same as driving an automobile.

INTRODUCTION

ATTENTION OWNER/OPERATOR

BEFORE OPERATING THIS MACHINE:

1. Carefully read the Operator's Manual, completely understand the Safety Messages and instructions, and know how to operate correctly both the tractor and Mower.
2. Fill out the Warranty Card in full. Be sure to answer all questions, including the Serial Number of the Mower. Mail within 30 days of delivery date of this implement.

NOTE: Warranties are honored only if completed "Owner Registration and Warranty" forms are received by Alamo Group within thirty days of delivery of the mower.

3. Record the Mower Model and Serial Numbers on the Warranty page at the front of the Operator's Manual. Keep this as part of the permanent maintenance file for the Mower.



CAUTION



FOR YOUR SAFETY AND TO GUARANTEE OPTIMUM PRODUCT RELIABILITY, ALWAYS USE GENUINE ALAMO REPLACEMENT PARTS. THE USE OF INFERIOR "WILL-FIT" PARTS WILL VOID WARRANTY OF YOUR ALAMO IMPLEMENT AND MAY CAUSE PREMATURE OR CATASTROPHIC FAILURE WHICH COULD RESULT IN SERIOUS INJURY OR DEATH. IF YOU HAVE ANY QUESTIONS CONCERNING THE REPAIR PARTS YOU ARE USING, CONTACT ALAMO, P. O. BOX 549, SEGUIN, TX 78156.

02925100

ASSEMBLY

DEALER SET-UP INSTRUCTIONS

Set up mower as received from factory with these instructions. Refer to complete check list when set -up is finished.

Select a suitable working area. Open parts box and lay out parts to make location easy. Refer to Parts Lists in Section 6 of manual and packing list. Cut all wire ties.

This mower is shipped partially assembled. Assembly will be easier if components are aligned and loosely assembled before tightening hardware. Refer to bolt torque chart in Maintenance Section. All bolts are Grade 5 unless otherwise specified.

1. Position on flat surface.
2. Apply light oil to gear box input shaft.

SHEAR PIN DRIVELINE INSTALLATION

Attach rear driveline of U-Joint to input Shaft on gearbox, install Snap Ring in groove on Input Shaft. **NOTE:** Check that Snap Ring is properly seated in groove. This Snap Ring retains Driveline when shear pin shears. Install Grade 2 (only) shear bolt 1/2" by 3-1/2". Use of a stronger shear pin than Grade 2, will result in driveline failure and will void warranty. Figure 1, Figure 2. Refer to proper Torque Chart in Maintenance Section of this manual.

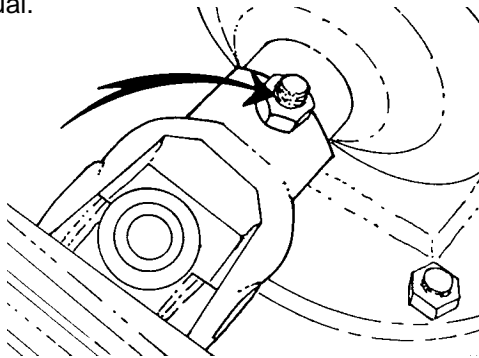

FIGURE 1. Grade 2 Shear Bolt

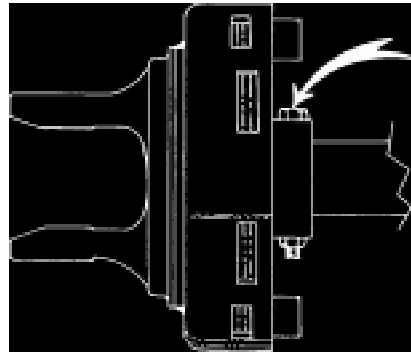

FIGURE 2. Grade 8 Bolt used with Slip Clutch

SHIELD ASSEMBLY

Before installing gearbox shields, check lubricant level in gearbox. Refer to Maintenance Section - Gearbox. Split cotter pins (#6) and insert the last links of chain (#5) through them. Attach cotter pin (#6) through top shield bracket (#2) from outside in. Remove the top two bolts on the front of the gearbox housing. Align holes in the top shield bracket (#2) and gearbox. Reinstall the bolts & lockwasher (torque to 33 ft. lbs.) Attach cotter pin (#6) through top shield (#1) from outside in. Attach shield (#1) to top bracket (#2) and secure with flatwasher (#3) and nut (#4).

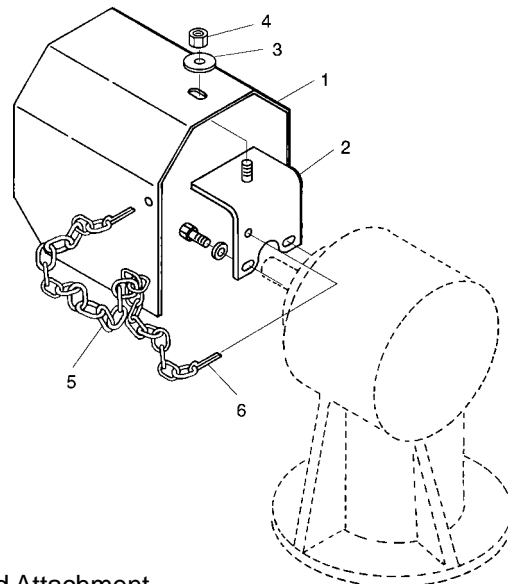

FIGURE 3. Gearbox Shield Attachment

ASSEMBLY

LIFT TYPE

A-FRAME INSTALLATION (FIGURE 4).

1. Attach "A" Frames (1) to inside of welded hitch brackets on Mainframe, insert Hitch Pin (12), flatwasher (11), lockwasher (14) and install nut (13).
2. Install lift straps (3) on inside of top rails on mainshield (behind gearbox mount) and attach with 1/2" x 1-1/2" bolts (10) and locknuts (9).
3. Insert spacer (7) between "A"- frames insert 3/4" x 6" bolts (8) thru hole in lift straps and spacer (7). Secure with 3/4" locknut (9).

TAIL WHEEL INSTALLATION (FIGURE 4).

5. Align tailwheel beam weldment (16) between pivot brackets located behind gearbox mount on mainshield weldment. **NOTE:** Long side of caster fork pivot tube is positioned up. Attach tailwheel beam weldment to mainshield with 5/8" x 3-1/2" bolt (5) and locknut (6).
6. Insert caster fork assembly (19) into tailwheel beam weldment (16). Install washer (17) and secure with cotter pin (18).
7. Position tailwheel beam weldment between tailwheel adjusting brackets on mainshield weldment and secure with two 1/2" x 3" bolts (8) and locknut (9).
8. Tighten all bolts to the proper torque.

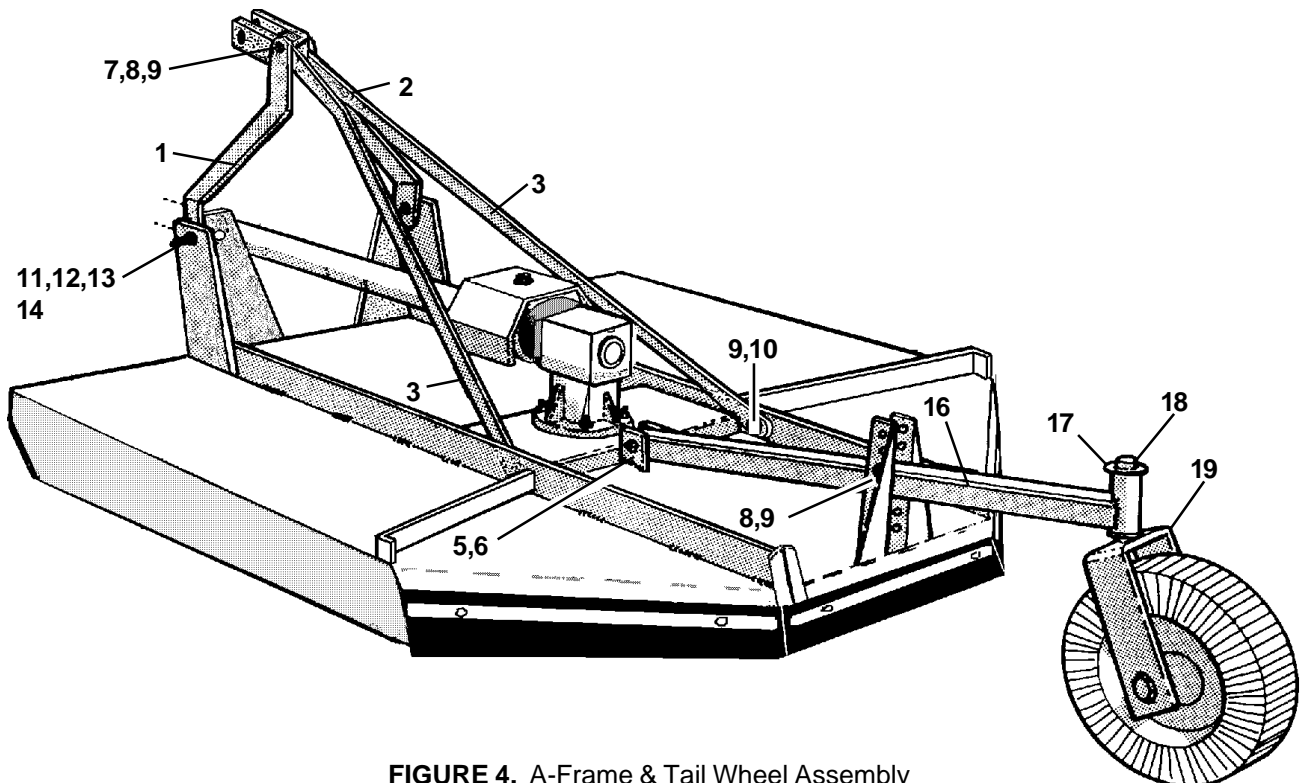

FIGURE 4. A-Frame & Tail Wheel Assembly

ASSEMBLY

HYDRAULIC RELIEF ASSEMBLY (P/N 3570) FIGURE 5

Hydraulic Relief Assembly (3570), also known as check chain, is available for attachment to front of cutter as an accessory. Check chains are used to control cut height and especially allows cutter to always be lowered to the same preset cut height.

Drill a 11/16" hole through each lifting lug 2-1/2" below the lift pins and 5/8" from the front of the lug. **Figure 5.**

Install lower end of check chain (4) to hitch ears, through lower holes using capscrews and lockwashers. Tighten securely.

Install chain lugs (3) on either side of tractor top link mounting (5) using bolt or pin of required diameter and length. Cat. I kit requires a 3/4" diameter bolt. Install top end of check chains in brackets (3).

Cutting height is then set by placing proper chain link in keyhole slot. Cutting height is easily adjustable by hooking chain higher or lower in the keyhole brackets (3).

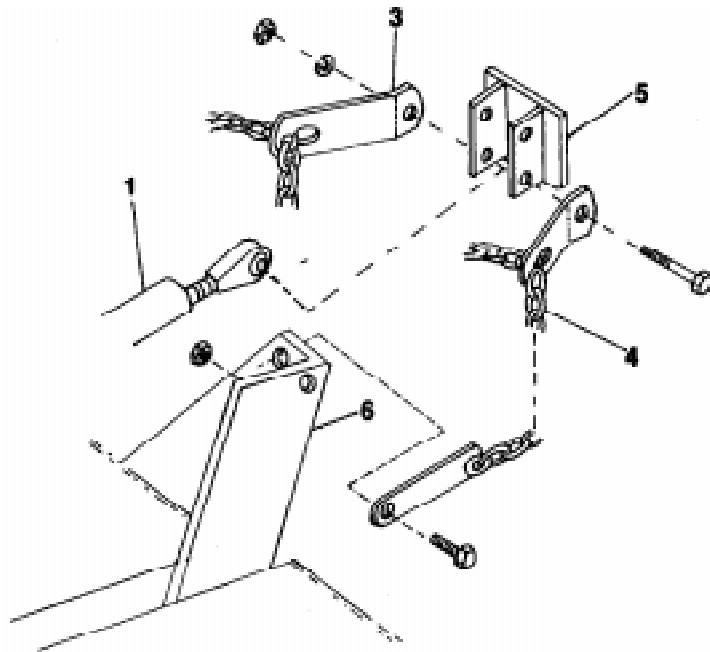

1. Tractor Top Link
3. Chain Lug
4. Check Chain
5. Tractor Top Link Mtg.
6. Hitch Bracket

FIGURE 5. Hydraulic Relief Assembly

NOTE: For additional safety in transport, raise mower as high as possible without having driveline hit decks and shorten check chains all possible to prevent inadvertent falling in transport.

ASSEMBLY

PULL TYPE

REAR AXLE ASSEMBLY

1. Insert lugs welded on rear axle (1) between Main Frame flats. Install bushings (15) in lugs on axle. Install bolts (2) with flatwashers (16) against bushings (15). Install locknuts (3). **Figure 6**

2. Insert tube assembly (8) between tailwheel adjusting brackets at rear of main deck, and insert bolt (4) through brackets and tube assembly (8). Install locknuts (5). (**NOTE: Always use bottom holes in adjusting bracket.**) **Figure 6.**

3. Insert trunion (7) into vertical lugs on axle (1). Insert bushing (12) over screw assembly (17) then insert screw assembly (17) through hole in trunion (7). Install Jam nut (6) onto screw assembly (17) and then screw into tube assembly (8). **Figure 6.**

4. Attach level rod pipe (14) to lug on rear axle (1) using bushing (15) inserted in axle lug and retained using bolt (2) with flatwasher (16) against bushing (15) and locknut (3). **Figure 6.**

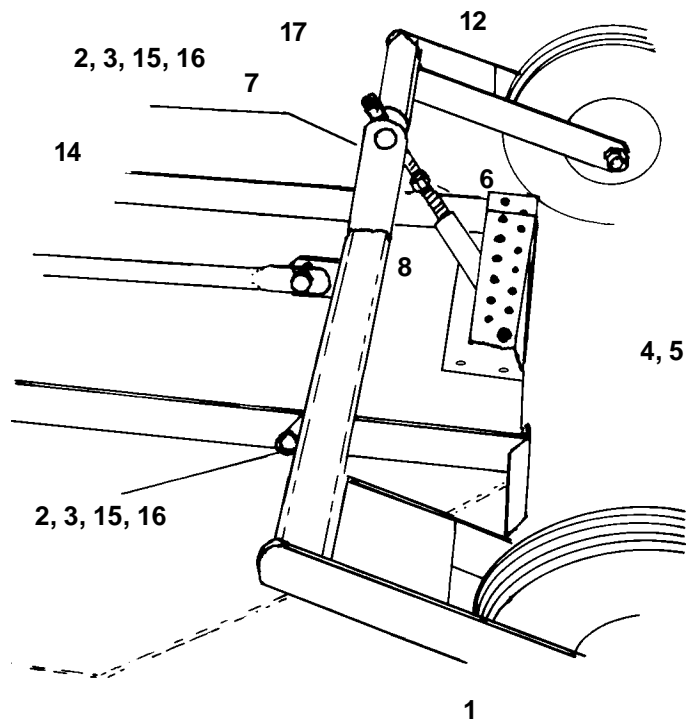

FIGURE 6. Rear Axle Assembly

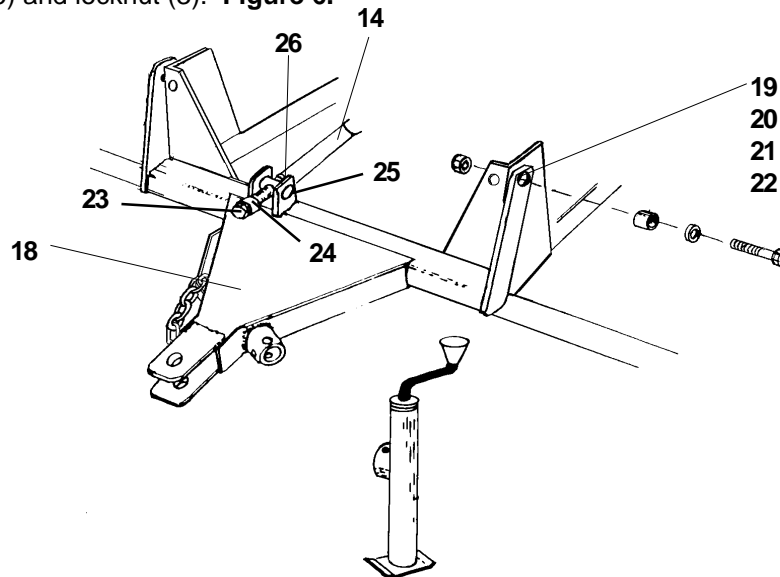

FIGURE 7. Tongue Assembly

5. Insert tongue (18) between lugs on front of deck. Install bushings (19) in Main Frame lugs and install bolts (20) with flatwasher (21) against bushing (19). Install locknut (22). **Figure 7.**

6. Slide bushing (24) over screw assembly (23). Insert trunion (25) through vertical lugs on tongue (18). Insert screw assembly (23) through trunion (25), install Jamnut (26) and thread screw assembly (23) into level rod. **Figure 7.**

ASSEMBLY

FRONT AND REAR DEFLECTORS AND CHAIN GUARDS

Front & Rear Deflectors are standard equipment.

The Front and Rear Chain Guards are Extra Equipment and are recommended to be used at all times to prevent injury caused by flying objects when mowing with persons or roadways in the area.

The Front Chain Guard should be attached by using four 1/2" Hex. Hd. Capscrews, Washers, and Nuts as shown in **Figure 8**.

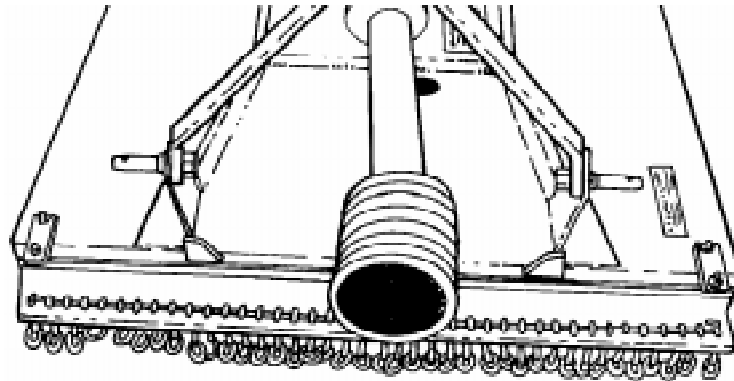

FIGURE 8. Front Chain Guard

The Rear Chain Guard is in three sections, two side sections and a center section. Two 1/2" Hex. Hd. Bolts, Washers and Nuts are required to attach each section, as shown in **Figure 9**.

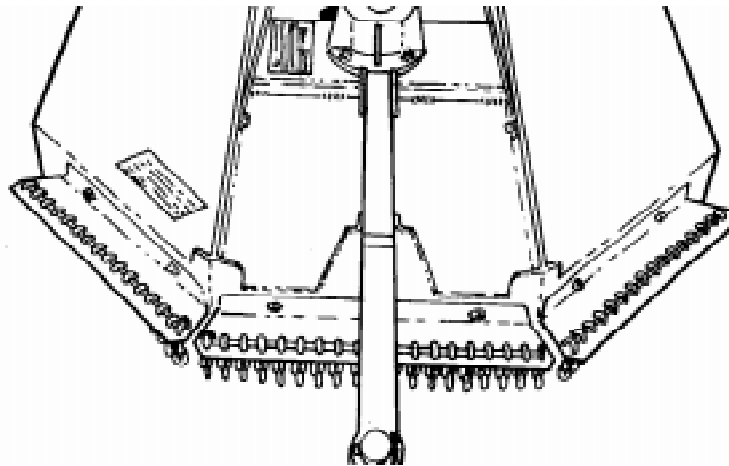

FIGURE 9. Rear Chain Guard

OPERATION

The safe operation of this machine is the responsibility of the operator. The operator should be familiar with the cutter and tractor and all safety practices before starting operation. This cutter is designed primarily for weed and grass control in pastures and along highway right-of-ways. It is equipped with suction Blades. Recommended cutting speed for most conditions is from 2 to 5 mph. Always operate tractor PTO at 540 RPM.

IMPORTANT: To avoid damage to cutter, retorque all bolts after the first 10 hours of operation. Retorque blade carrier retaining nut on gearbox lower shaft to 450 ft. lbs.

MOWER PREPARATION

LIFT-TYPE:

The Category 1 Hitch, standard on the 60 Mower, requires no adapters to attach to a tractor with a Category, 3-Point Hitch.

The tractor Lift Arms are attached to the Lift Pins.

PULL-TYPE:

No adapters are required for attaching a standard Pull-Type Unit to a tractor with 540 RPM PTO. Proper distance between the Drawbar Hitch and the tractor PTO must be maintained for satisfactory operation.

Figure 1.

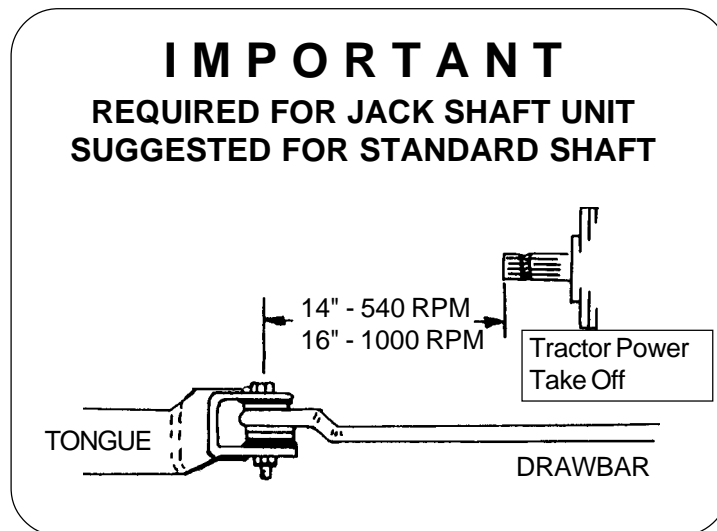

OPERATION

TRACTOR PREPARATION - Lift Type

Ballast

An implement code of 7.85 has been assigned to the fully-equipped Lift-Type SE5 mower so that you can determine the tractor front ballast requirements. Refer to your tractor Operator's manual for the code number and ballasting requirements.

WARNING Do not operate with less than 20% of tractor's gross unballasted mass on front Wheel with Shredder in transport position.



Wheel Treads

Tractor wheel tread spacing should be increased when working on inclines or rough ground to reduce the possibility of tipping.

Stabilizer Bars or Sway Blocks

Use stabilizer bars or sway blocks to prevent side sway of the mower. Stabilizer bars must be used with the Offset Adapter.

Draft Links

The linkage to the Lower Draft Links should be set in the "float" position, allowing the unit to follow the contour of the terrain.

Drawbar

Shorten or remove the tractor Drawbar so it will not interfere with the up and down movement of the Mower.

WARNING Do not get between Tractor and Mower when engine is running!



ATTACHING MOWER TO TRACTOR - LIFT TYPE

Back the tractor up to the Shredder so that the lower Draft Arms are in alignment with the Shredder lower lift Pins. Stop the engine, lock the brakes or place the tractor in park. Connect the tractor and Stabilizer Bars to the lower Lift Pins. Adjust the Top Link so it will pin to the top holes in the A-Frame.

OPERATION

ATTACHING MOWER TO TRACTOR - PULL TYPE

Block the mower wheels in place and use the Parking Jack to raise to the Tongue Clevis to the correct attaching height.

Adjust the tractor drawbar to proper length to provide dimensions shown in **figure 2** for proper Driveline attachment at 540 RPM PTO speed as indicated on the Mower.

Keep every one clear and back toward the Mower until holes in clevis and tractor drawbar are aligned.

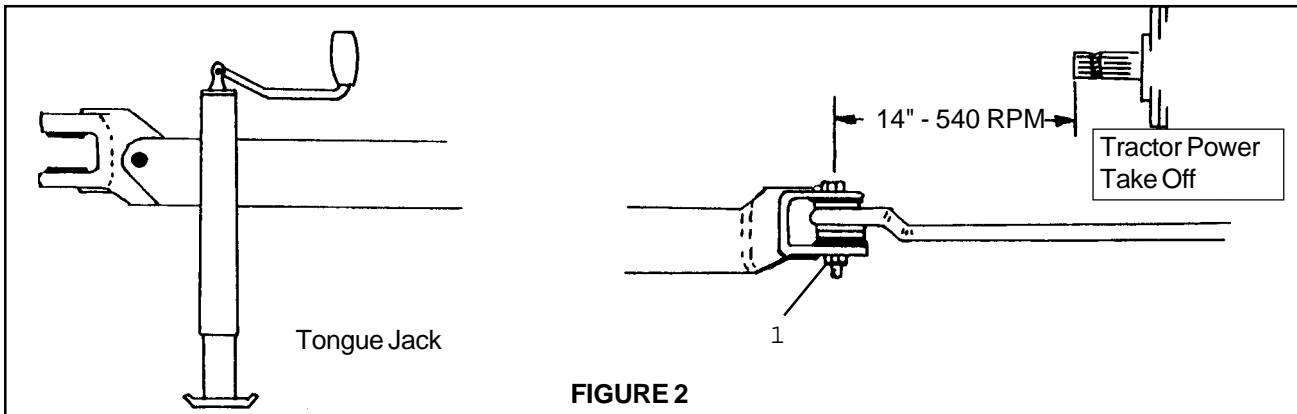

Install a 3/4" grade 5 or 8 bolt (4-1/2" long) through clevis and drawbar. Install a locknut (1) onto the bolt beneath the Clevis and tighten the locknut & bolt securely. See **Figure2**.

NOTE: If attaching Mower Clevis to a three -point-hitch drawbar, tractor drawbar must extend to rear to allow turning without binding in the Tongue Clevis. **DO NOT USE THIS TYPE DRAWBAR WITHOUT STABILIZERS.**

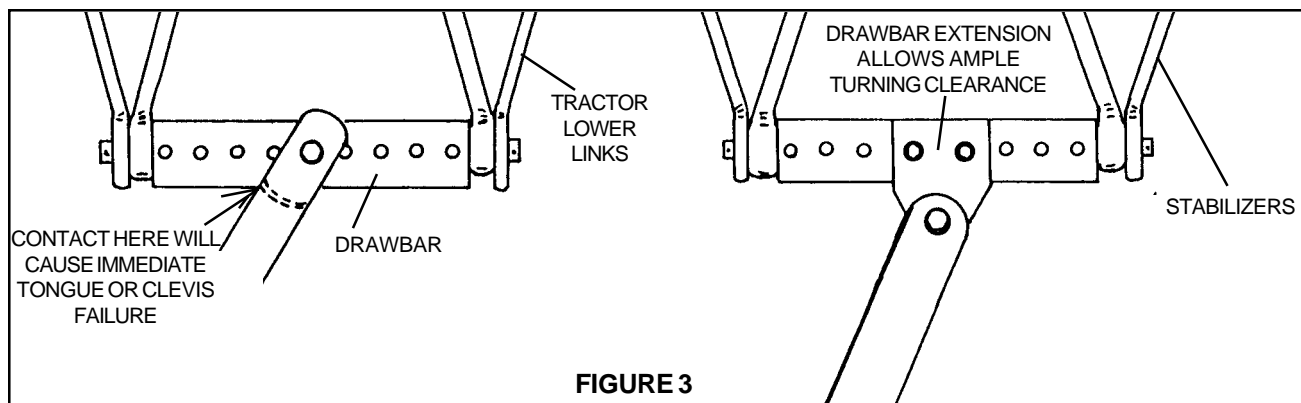

See art below.

NOTE: NEVER ATTACH MOWER TO TRACTOR WITH A PIN NOT HAVING A NUT.

The two halves of the Clevis must be bolted together securely to carry the load properly without springing or breaking the Clevis.

DANGER!



Failure to adjust the Drawbar to the CORRECT LENGTH, failure to PROVIDE DRAWBAR CLEARANCE sufficient for short turns, and/or failure to ATTACH CLEVIS TO THE DRAWBAR correctly and securely MAY ALLOW THE MOWER TO SEPARATE FROM THE TRACTOR AND/OR THE DRIVELINE HALVES TO SEPARATE WHICH CAN CAUSE SERIOUS BODILY INJURY OR DEATH TO THE OPERATOR OR OTHERS.

OPERATION

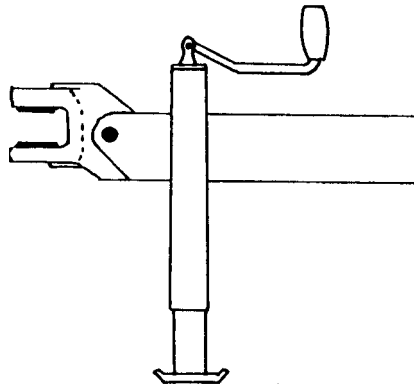

FIGURE 4. Parking Jack

PARKING JACK

NOTE: Always place jack foot on firm surface or place board under jack for support.

When removing parking jack from tongue, place on storage bracket on left side of main frame.

Driveline Attachment to Tractor

1. Grab and pull collar on end of attaching yoke toward cutter.
2. Slide yoke (with collar depressed) onto PTO shaft.
3. Move yoke back and forth until locking collar clicks forward and locks the yoke in place.

WARNING! A Loose shaft could slip off and result in personal injury or damage to mower. When attaching PTO yoke to tractor PTO shaft, it is important that spring-activated locking collar slides freely and locking balls are seated in groove on PTO shaft.



Safety Chains - Pull Type

When towing implements on the highway, use a safety chain with tensile strength equal to or greater than the gross weight of the implement to be towed by the tractor. This will control the implement in the event the hitch pin is lost.

After attaching the safety chain, make a trial run by driving the tractor to the right and to the left for a short distance to check the safety chain adjustment. If necessary, readjust to eliminate tight or loose chain.

Safety chains and attaching hardware are available from your tractor dealer.

OPERATION

CUTTING HEIGHT ADJUSTMENT

WARNING



Avoid personal injury! Be sure tractor engine is off, key is removed, and ALLOW BLADES TO STOP TURNING before dismounting to make adjustments.

Important: Avoid very low cutting heights. Striking the ground with blades gives the most damaging shock loads a cutter can encounter and will cause damage to cutter and drive.

To achieve maximum cutting efficiency and provide the most uniform cut, the cutter should be operated with the rear of cutter slightly higher (1/2" - 3/4") than the front.

LIFT-TYPE

1. Place tractor and cutter on level surface.
2. Raise the cutter to approximate desired cutting height with tractor hydraulic lift control lever.
3. Loosen or remove clamp bolts on gauge wheel frame tubes. Insert top bolt at desired cutting height. Insert bottom bolt in hole which clears tube. Tighten bolts. **NOTE:** Do not overtighten bolts as this may distort brackets.

NOTE: Install OPTIONAL check chains when there is a problem with tractor hydraulic system or when a constant preadjusted cut height is required. See check chain accessory.

4. Lower the cutter slowly until cutter is 1/2" - 3/4" higher at rear than at front. Position the adjustable stop on the tractor lift quadrant against the lift control lever so the cutter can be returned to the same height.
5. Adjust the length of the top link so that when lifting the cutter the front of the cutter will raise 2 to 2-1/2 inches before the gauge wheels leave the ground. (This will allow the flexible hitch to pivot and allow the cutter to follow the contour on uneven ground.)
6. Level the cutter side to side with the tractor lower link adjustment.

IMPORTANT: When raising cutter to transport height, be sure there is clearance between the cutter and driveline. Damage will result if driveline hits cutter deck.

PULL-TYPE

1. Place tractor and cutter on level surface.
2. Using Screw Assembly, raise or lower mower to approximate cutting height.
3. Level the cutter deck front to rear, by adjusting the leveling rod linking the tongue and rear axle. To lower front, lengthen level rod and to raise front, shorten level rod. **Figure 5.**

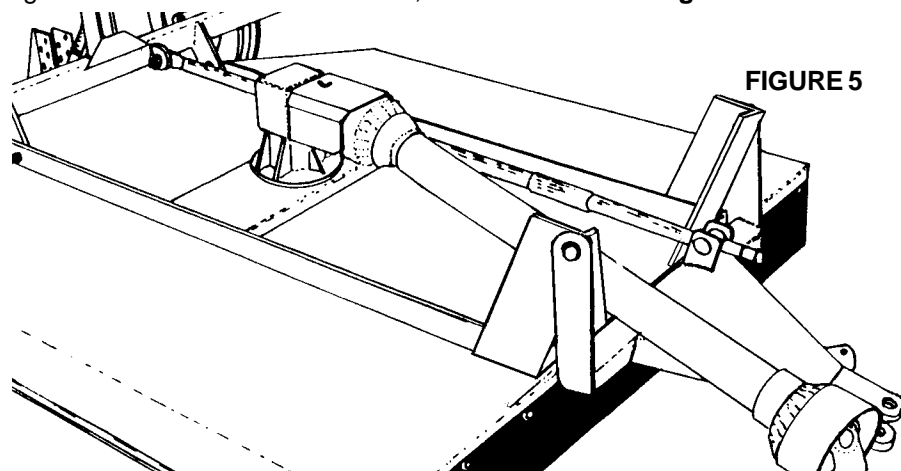

OPERATION

STARTING & STOPPING CUTTER

Power for operating cutter is supplied from tractor PTO. Refer to your tractor manual instructions for engaging and disengaging the PTO. Always engage the PTO at low engine rpm. Always operate at recommended PTO speed of 540 RPM. Learn how to stop tractor and cutter quickly in case of an emergency.

IMPORTANT: Stop cutter and tractor immediately upon striking an obstruction. Inspect the cutter and repair any damage before resuming operation. **Do not disengage PTO when engine is at full PTO RPM. Always idle engine before disengaging PTO.**

WARNING!



Avoid personal injury. When attempting to stop a tractor which does not have live PTO, the momentum created by the blade carrier of a rotary cutter can cause the tractor to be pushed forward. **DO NOT** operate this cutter unless tractor has live or independent PTO.

To commence operation, reduce engine speed and engage the tractor PTO. Before starting to cut, gradually increase engine speed to develop full PTO speed.

DANGER!



Chain guards must be installed if operating with people or livestock in the area or close to highways or buildings and in all non-agricultural operations.

Enter the area to cut with the cutter operating at PTO speed and, if it becomes necessary to temporarily regulate engine speed during operations, increase or decrease the throttle gradually.

To transport, disengage the PTO, raise full transport height.

CUTTING SPEED

Proper ground speed for cutting will depend upon the height, type, and density of material to be cut.

Normally, ground speed will range from 2 to 5 mph. Tall dense material should be cut at low speed while thin medium height material can be cut at a faster ground speed.

CUTTING TIPS

Always operate PTO at recommended RPM when cutting. This is necessary to maintain proper blade speed and to produce a clean cut.

Under certain conditions, tractor tires may roll some grasses down and prevent them from being cut at the same height as the surrounding area. When this occurs, reduce the tractor ground speed, but maintain PTO RPM. The lower speed will permit grasses to be at least partially rebound and be cut. Taking a partial cut and/or reversing the direction of travel may also produce a cleaner cut.

As often as possible, stop mowing when other people are passing by. Although the Mower is shielded to prevent objects from being thrown out by the blades, no one shield device is 100% effective. The safest possible course is the only sensible approach to the problem of endangering a passerby. The operator has greater knowledge of the dangers of being around this Mower while it is operational than the person on the street.

WARNING!



Avoid personal injury. Pick up all rocks and other debris before cutting. Enter new areas carefully. Cut material higher the first time to allow cutter to clear unseen objects. Never assume an area is clear. Always check.

Extremely tall grass should be cut twice. Raise cutter and cut twice the desired height. Cut the second time at desired height at 90 degrees to the first pass.

Remember, sharp blades produce cleaner cuts and use less power.

Before cutting, analyze the area to determine the best cutting procedure. Consider the height and type of material and the terrain type: hilly, level or rough.

OPERATION

DETACHING AND STORING

Lower the Mower to the Ground. Park the Tractor with the transmission in the correct gear (Automatic Transmission--Park; Standard Transmission--Neutral). Set the parking brake, shut off the engine, and remove the key. Wait until the PTO stops rotating before getting down from the tractor.

Disconnect the Driveline from the tractor PTO. Disconnect the Top Link and the Lower Lift Links from the Mower.

If this is a Pull-Type, raise Tongue with Jack. Disconnect Driveline. Remove Hitch Bolt.

Always reinstall the Master Shield over the tractor PTO Shaft. This Shield should always remain in place except when connecting or disconnecting Driveline.

Keep hands and feet out from under Tongue or Shredder.

BEFORE OPERATING OR TRANSPORTING THIS MOWER:

Always display this SMV emblem (**Figure 6**) on the rear of the tractor transporting this mower where it is clearly visible to oncoming traffic. Prominent display of this symbol will help the operator avoid accidents which could cause injury or possibly death.

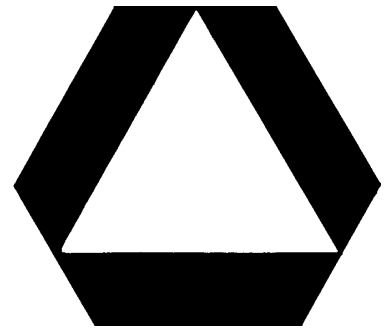

FIGURE 6. SMV Emblem.

DRIVELINE LENGTH CHECK PROCEDURE

WARNING!



A loose shaft could slip off and result in personal injury or damage to cutter. When attaching PTO yoke to tractor PTO shaft, it is important that spring activated locking collar slides freely and locking balls are seated in groove on PTO shaft.

WARNING!



Before operating cutter, check to make sure the driveline will not bottom out or become disengage.

- Disengage the Driveline from the tractor PTO Shaft.
- Slide the Driveline together until it "bottoms out" solidly.
- Apply colored tape to the Inner Shield 1/8" from the end of the Outer Shield. **Figure 7.**
- Re-attach the Driveline to the PTO Shaft.

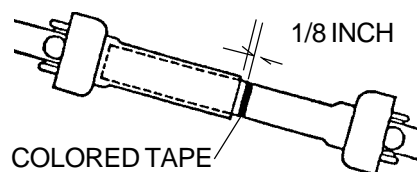

Driveline in maximum compressed position

FIGURE 7. Driveline Length Check

OPERATION

Pull Type

With the PTO NOT TURNING, slowly drive the tractor with cutter attached through sharpest turn possible and watch shaft movement.

With the PTO NOT TURNING, slowly drive the tractor with Cutter attached through the most severe terrain conditions expected and watch Shaft movement.

Check position which places driveline at maximum extended length and at maximum compressed length. Maximum extended length must always maintain at least 12 inches of profile tube engagement. Maximum compressed length should always maintain 1-9/16 clearance.

If driveline cannot be shortened and still maintain 12 inches of tube engagement then the operator should note test so the operator can recognize the terrain conditions that might cause the problem and avoid possible damage by disconnecting driveline from tractor or crossing terrain in different manner. See special instructions for rough terrain operations.

SPECIAL INSTRUCTIONS FOR ROUGH TERRAIN OPERATIONS

Pull Type Only

When crossing ditches with steep banks or going up sharp inclines, it is possible to "bottom out" the Driveline that connects the tractor PTO to the Gearbox on mower.

Note: To bottom out means that the Inner Shaft has penetrated into the Outer Housing to its maximum depth until the Assembly becomes solid - it can shorten no more. See **Figure 8**.

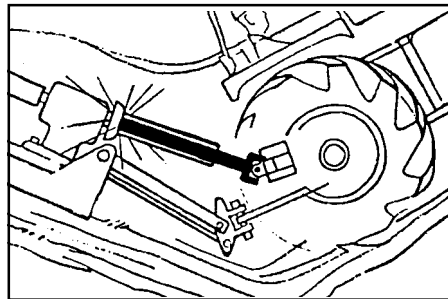

**Driveline bottom out.
FIGURE 8**

If this happens, it can cause serious damage to the tractor PTO by pushing the PTO into the tractor and through the Support Bearings or downward onto the PTO Shaft, breaking it off.

WARNING!



Either failure can allow the Driveline to come loose from the tractor which could cause bodily injury to the operator or others in the vicinity along with expensive damage to the tractor and/or Cutter.

OPERATION

If you have a condition where your tractor will be going up a steep incline with your mower still on the flat area or coming down the opposite incline, you have a potential problem. **Figure 10.** The correct preventive measure is to instruct the operator to cross this kind of terrain at an angle. **Figure 9.** This will reduce the angle between the tractor and the Mower. The problem is more likely to occur if the Mower is in the raised position while the tractor is turning sharply and going up an incline.

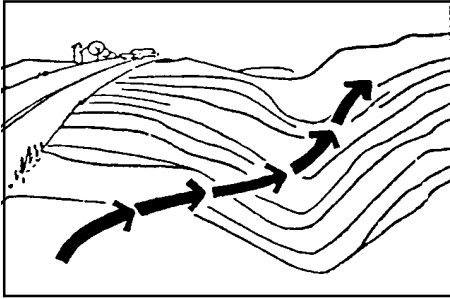

CORRECT: Approach ditch at an angle
FIGURE 9

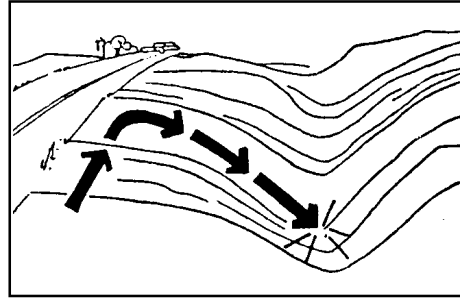

INCORRECT: DO NOT approach ditch straight on.
FIGURE 10

TRANSPORTING

Pay particularly close attention to the Safety Messages regarding Mower transport. Avoid unnecessary injuries and equipment damage by exercising cautious, conscientious, travel procedures.

Attaching the Mower to the Tractor increases the overall length of the working unit. Allow additional clearance for the Mower to swing when turning.

Raise the Mower as high as possible for transporting while maintaining clearance between the Driveline and Deck of the three-Point Lift Mower.

Pneumatic tire pressure should be kept at around 20 psi to decrease shock during transport. When using puncture-proof, Laminated Tires, be sure that the flat side of the Lug Nut is against the wheel.

When using the hydraulic Relief, adjust as described earlier for safer transport.

WARNING  When transporting the Mower on a road or highway, use the tractor warning lights, SMV Sign, Reflectors, and other devices for adequate warning to the operators of other vehicles. Check the traffic regulations governing the locale where mowing is to be done, and work safely within those structures.

CAUTION  Be sure that the tractor Lift Lever is locked into the "transport" detent before attempting to transport the Mower. Make certain that atleast 20% of tractor weight is on front tires.

CAUTION  Hold transport speed to 15 mph especially when using puncture-proof, Laminated Tires. These tires are designed for off-road use only. They can be used on road surfaces at very low speeds and then only for a short distance. Heat from pavement friction can build up causing the tire to ignite. The steel band holding the sections in place could bread, causing extensive damage to the Mower and tractor as well as possible injury to the operator and passerby. When transporting up slopes with reduced front end weight, the tailwheel may be lowered all possible to provide stop if tractor rears up.

OPERATION

OFFSET ADAPTER (FIGURE 11)

Fasten the Offset Adapter Tube to the three-Point Lift Lugs using the hitch Pin Holes. Fasten the Adjustable Leg to the right Lug to offset the Mower to the right. Fasten the Adjustable Leg to the left Lug to offset the Mower to the Left. The Mower will cut cleaner behind the wheel tracks if it is offset to the left.

Install the Adapter Brace Bar to one gearbox mounting bolt. Fasten the Chain End to the Mainframe (hole in left Stiffener). Adjust the Brace Bar so the Adapter is in a near perpendicular position.

Attach the Mower to the tractor. Attach Stabilizer Bars to prevent side sway of Mower.

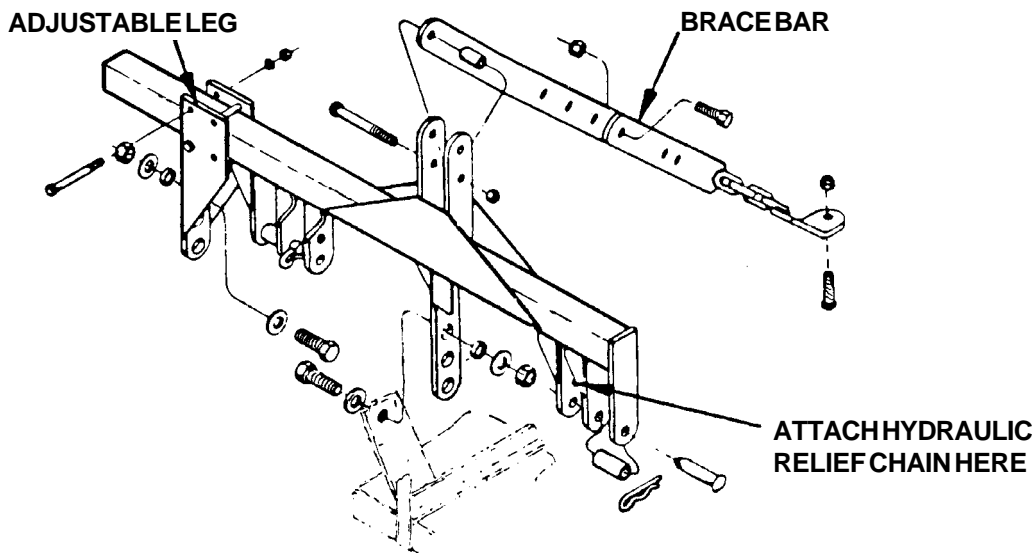

FIGURE 11. Offset Adapter.



CAUTION



FOR YOUR SAFETY AND TO GUARANTEE OPTIMUM PRODUCT RELIABILITY, ALWAYS USE GENUINE ALAMO REPLACEMENT PARTS. THE USE OF INFERIOR "WILL-FIT" PARTS WILL VOID WARRANTY OF YOUR ALAMO IMPLEMENT AND MAY CAUSE PREMATURE OR CATASTROPHIC FAILURE WHICH COULD RESULT IN SERIOUS INJURY OR DEATH. IF YOU HAVE ANY QUESTIONS CONCERNING THE REPAIR PARTS YOU ARE USING, CONTACT ALAMO, P. O. BOX 549, SEGUIN, TX 78156.

02925100

OPERATION

TROUBLE SHOOTING GUIDE

TROUBLE	POSSIBLE CAUSE	POSSIBLE REMEDY
Excessive Vibration	1. Check Gearbox bolts.	Tighten if loose.
	2. Check for loose nuts on bladeholder and blades.	Tighten if loose.
	3. Check for bent output shaft. If shaft is bent, oil will normally leak from bottom seal.	Replace shaft if bent.
	4. Check to see if blades are free swinging.	Free Blades so they swing.
	5. Check for even wear on each blade tip. Were both blades changed at the same time?	Weigh Blades. Weight should be within 1 oz. Always replace both blades.
	6. Blade broken.	Replace blades, in set.
	7. Blade carrier bent.	Replace carrier.
	8. Blade hub not properly seated on shaft.	Remove hub, check tapered spline shaft, clean and replace.
	9. New blade or bolts matched with worn blade or bolts.	Replace blades or bolts in sets.
	10. Drivelines not phased correctly. Implement & tractor yokes must be in line.	Replace driveline
Rapid Clevis Wear	1. Washers not used.	Install washers above & below drawbar.
Clevis bending or spreading open	1. Using Pin or Bolt not tightenend.	Use 1" gr5 or 8 bolt & tighten nut.
Tongue bending or binding in turns	1. Improper Drawbar.	Add Attaching Plate to all 3-Point drawbars.
Gearbox Overheating	1. Low on lubricant.	Fill to level plug.
	2. Improper type lubricant.	Replace with proper lubricant.
	3. Excessive trash build-up around gearbox.	Remove trash.
	4. Bearing or gears set up improperly.	Consult your Dealer.

OPERATION

TROUBLE SHOOTING GUIDE

TROUBLE	POSSIBLE CAUSE	POSSIBLE REMEDY
Not Cutting Clean	1. Blades dull.	Sharpen or replace blades.
	2. Carrier RPM too low.	Use correct PTO speed and check for correct gearbox ratio. See specifications.
	3. Cutter not level.	See Cutting Height Adjustment.
	4. Tractor tires mashing down grass.	Reverse direction of cutting and drive with one tractor tire out of cutter overlap area. Conditions too wet to cut.
	5. Ground speed too fast.	Reduce ground speed by shifting to a lower gear.
	6. Blades locked back.	Free blades.
	7. Blades riding up due to blade bolt wear or loose bolts.	Replace blade bolts.
Streaking Conditions	1. Conditions too wet for cutting. Blades unable to cut that part of grass pressed down by path of tractor tires.	Allow grass to dry before cutting. Slow ground speed of tractor but keep engine running at full PTO rpm. Cutting lower may help.
	2. Dull blades.	Sharpen or replace blades.
	3. Height of cutter lower at rear or front.	See Cutting Height Instructions.
Blade Bolts	1. Bolts not tightened.	Tighten bolts to 350 ft.lbs.
	2. Bolt hole elongated or oversized.	Replace Bushing or Blade Carrier.
	3. Locknut worn out.	Replace Locknut.

OPERATION

TROUBLE SHOOTING GUIDE

TROUBLE	POSSIBLE CAUSE	POSSIBLE REMEDY
Gearbox Noisy	1. Rough Gears.	Run in or change gears.
	2. Worn Bearings.	Replace bearing.
Gearbox Leaking	1. Damaged oil seal.	Replace seal.
	2. Bent Shaft.	Replace oil seal and shaft.
	3. Shaft rough in oil seal area.	Replace or repair shaft.
	4. Oil seal installed wrong.	Replace seal.
	5. Oil seal not sealing in the housing.	Replace seal or use a sealant on OD of seal.
	6. Oil level too high.	Drain oil to proper level.
	7. Sand hole in casting.	Replace castings or gearbox.
	8. Gasket damaged.	Replace gasket.
	9. Bolts loose.	Tighten bolts.
Shear Pin Shears Excessively	1. Tractor PTO not being run at 540 RPM.	Run at 540 RPM.
	2. Heavy material.	Reduce ground speed. Raise cutting height.
	3. Not using proper pin.	Replace only with recommended shear pin.
Blade Wears Too Fast	1. Cutting in sandy conditions.	Increase cutting height.
	2. Cutting in rocky conditions.	Increase cutting height.

MAINTENANCE

Before operating your Rotary Cutter, make sure it is properly lubricated and thoroughly inspected. Only a minimum of time and effort is required to regularly lubricate and maintain this machine to provide long life and trouble free operation.

WARNING! Always disengage the PTO before raising the Rotary Cutter for transporting or making adjustments.



LUBRICATION INFORMATION

Do not let excess grease collect on or around parts, particularly when operating in sandy areas. The illustrations below shows lubrication points. The chart gives the frequency of lubrication in hours, based on normal operating conditions. Severe or unusual conditions may require more frequent lubrication. **Figure 1**

Use an SAE multi-purpose, lithium-type grease for all locations shown. Be sure to clean the fitting thoroughly before using grease gun. Daily lubrication of the driveline slip joint is necessary. Failure to maintain proper lubrication will result in damage to U-joints, gearbox, and/or driveshaft.

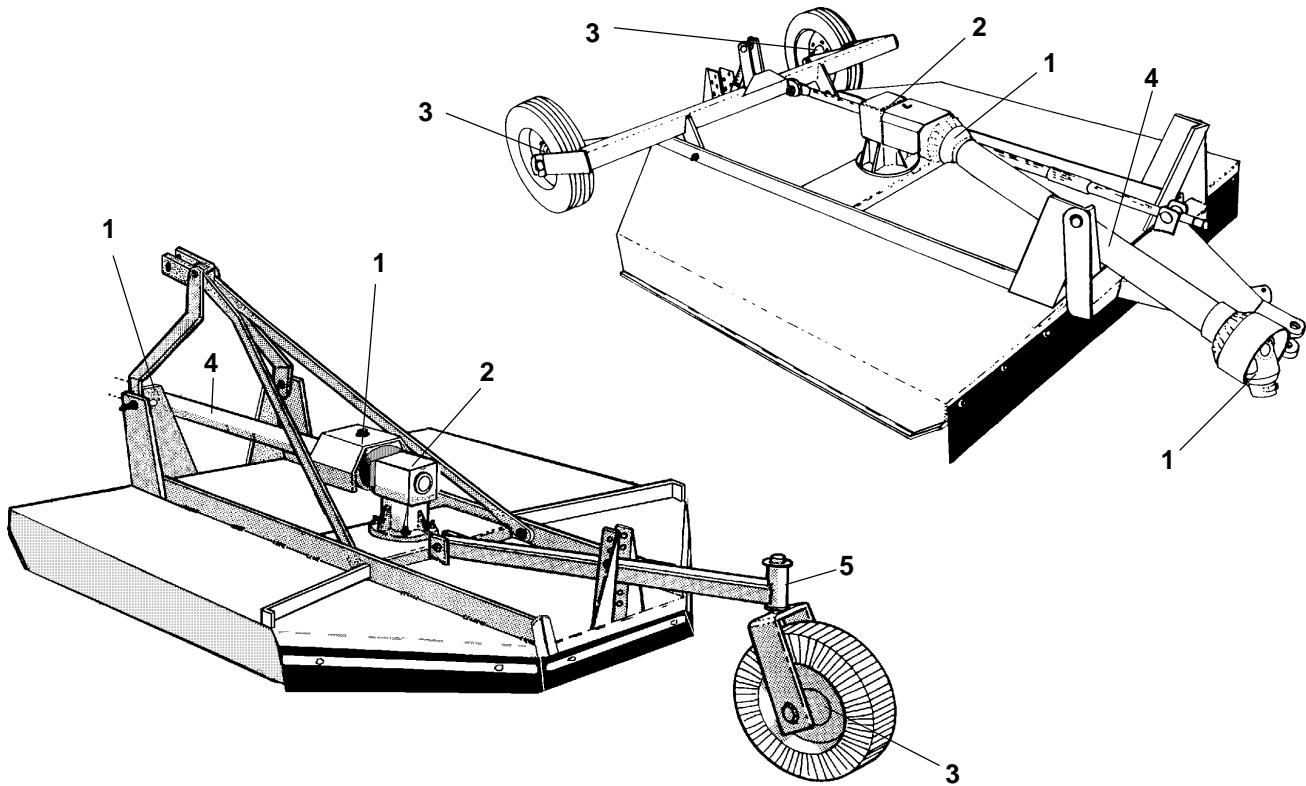

FIGURE 1. Lubrication Location

ITEM	DESCRIPTION	FREQUENCY
1	U-Joints	8 hours
2	Gearbox	Check daily
3	Wheel Hubs	Weekly
4	Telescoping	8 hours
5	Tailwheel Beam	8 hours

MAINTENANCE

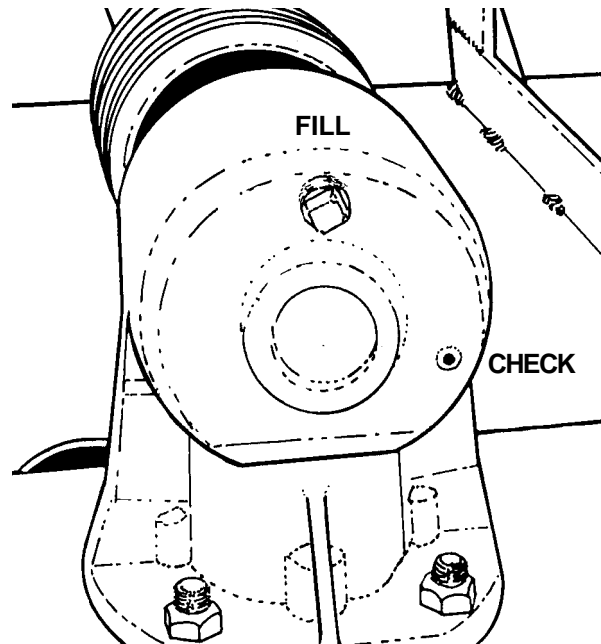

FIGURE 2. Gearbox Lubrication

GEARBOX

The gearbox should be full (18 ounces).54 liters and not require additional lubricant unless the box is cracked or a seal is leaking. It is recommended that the 1/8" oil level plug (**Figure 2**) be removed after every 10 hours of operation. If required, oil should be added until it runs out hole.

Recommended lubricant is NLGI 000 Grease, Alamo Group P/N 00765444.

NOTE: Make sure mower is level when checking oil in the gearbox.

NOTE: Overfilling of Gearbox will cause pressure to build up and cause Grease Seals to leak.



CAUTION



For your safety and to guarantee optimum product reliability, always use genuine ALAMO replacement parts. The use of inferior "will-fit" parts will void warranty of your ALAMO implement and may cause premature or catastrophic failure which can result in serious injury or death. If you have any questions concerning the repair parts you are using, contact ALAMO, POB 549, Seguin, TX 78156-0549

02925100

MAINTENANCE

DRIVELINE LUBRICATION

Grease Fittings are located on the Cross Assembly of each U-Joint and on the telescoping tubes. Grease the U-Joint after each 8 hours of use. **Figure 3.** Do not force grease through the Needle Cup Assemblies. Grease the telescoping tubes after every 8 hours use. To grease profile tube, disconnect drive from PTO and pull halves apart. Pump grease into outer profile tube and reinstall together. Lubricate the shield bearings every 16 hours. **Figure 4.**

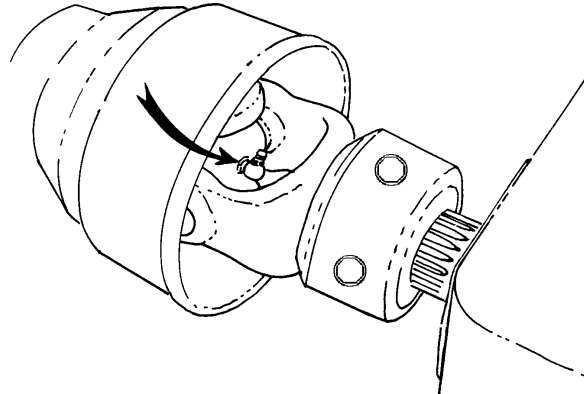

FIGURE 3. U-Joint Lubrication

The Driveline Integral Shields should not become dented or otherwise damaged. The Integral Shield Assembly has a Nylon Bearing at each end and should turn freely. This nylon bearing should require lubrication every 8 hours. To remove the Integral Shields for replacement or repair, turn the three Nylon Nuts 1/4 turn in the Shield Slots of the Cone and Tube and remove them. Slip the Shield Cone Assembly off inner section of the Driveline. Install the new or repaired Shield on the Driveline. Place the split Nylon Bearing over the Driveline Housing of Shaft against the Yoke and in the Bearing groove. Install shield over the Housing so the Nylon Bearing fits into the Shield Bearing Retainer. Align a slot in the Shield Cone with one of the slots in the Shield. Put one of the Nylon Nuts back in through the aligned slots and turn until it is perpendicular to the slots. Add the other two Nylon Nuts.

CAUTION!



Make certain that the Driveline Integral Shields are free to telescope and rotate around the Driveline without binding.

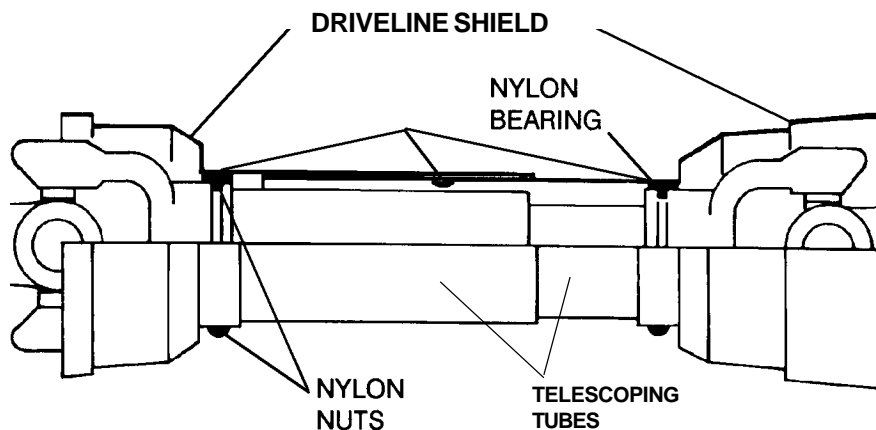

FIGURE 4. Driveline Maintenance

MAINTENANCE

WARNING!



When attaching PTO yoke to tractor PTO shaft, it is important that spring-activated locking collar slides freely and locking balls are seated in groove on PTO shaft. A loose shaft could slip off and result in personal injury or damage to cutter.

BLADE SERVICING

Inspect blades before each use to determine that they are properly installed and in good condition. Replace any blade that is bent, excessively nicked, worn, or has any other damage. Small nicks can be ground out when sharpening.

IMPORTANT! When sharpening blades, grind each blade the same amount to maintain balance. The difference in blade weights should not exceed 1 ounce. Unbalanced blades will cause excessive vibration which can damage gear box bearings. Vibration may also cause structural cracks in cutter housing.

WARNING!



Use only original equipment blades on this cutter. They are made of special heat-treated alloy steel. Substitute blades may not meet specifications and may fail in a hazardous manner that could cause injury.

BLADE SHARPENING

Always sharpen both blades at same time to maintain balance. Follow original sharpening pattern as shown in **Figure 5**. Always sharpen blades by grinding. **DO NOT** heat and pound out edge. Do not sharpen blade to a razor edge, but leave a 1/16" blunt edge. Do not sharpen back side of blade.

WARNING!



Avoid personal injury. Always block the cutter up to prevent it from falling when the blades and/or carrier are being serviced.

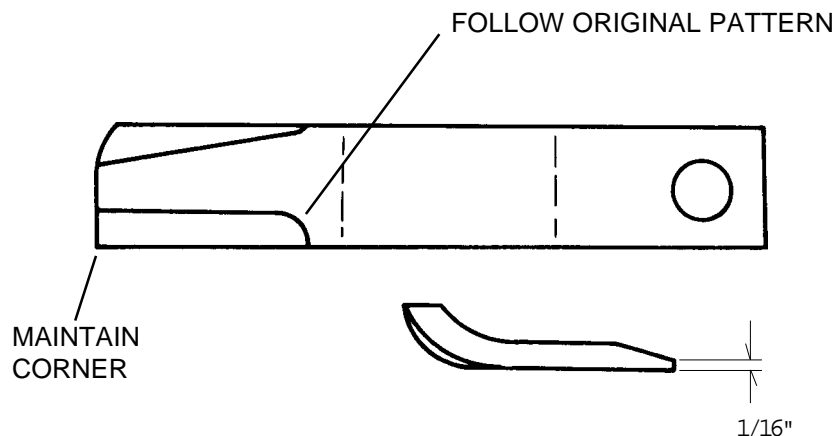

FIGURE 5. Blade Maintenance

MAINTENANCE

BLADE REMOVAL

To remove blades for sharpening or replacement, remove the cover plate on deck of cutter near gear box. Remove lock nut from blade bolt. **NOTE:** *Inspect lock nut after removal and replace if threads are damaged.* Always replace nut when replacing blade bolt. When installing blades be sure and check blade bolt pivot diameter for wear. Replace bolt if worn more than 1/4 inch at any point. Tighten lock nut to 350 ft. lbs.

WARNING!



Avoid personal injury. Blade and/or blade carrier removal should be done only with the tractor engine shut off, key removed, in neutral, parking brake on, and PTO disengaged and the cutter blocked in the raised position.

BLADE CARRIER REMOVAL

Remove cotter pin and loosen slotted nut on gearbox shaft. Loosen but do not remove the nut until the blade carrier is loosened. Use a suitable 2 jaw gear puller to pull carrier off tapered gearbox shaft. If gear puller is not available use long bar inserted through blade bolt access hole with end against rotor bar. Strike opposite end of bar with sledge hammer. Rotate blade carrier 180 degrees and repeat process.

BLADE CARRIER INSTALLATION

Clean the splines on both the blade carrier and output shaft. Position carrier on the gearbox output shaft and install special washer nut.

Tighten nut holding blade carrier to minimum 450 ft. pounds, strike the carrier near the hub several times with a heavy hammer to seat the hub. Use a suitable spacer over the nut to prevent damage to the nut and threads. Retighten the nut to 450 ft. pounds. Install cotter pin and spread.

IMPORTANT: Always recheck gearbox output shaft slotted blade carrier retaining nut torque after a few hours operation.

WARNING!



Avoid personal injury. Do not work under cutter without support blocks to keep frame from falling.

SLIP CLUTCH

A slip clutch is incorporated in the PTO driveline. It is designed to slip, absorb the shock load, and protect the driveline.

After the first hour of operation, the Slip Clutch should be checked for overheating. After this first check, the Slip Clutch should be checked weekly or anytime there is overheating. To adjust the Slip Clutch, tighten the Spring Bolts to 1-5/16" length. Any increase or decrease in this tightness will change the torque rating and could cause premature failure.

The Slip Clutch should be checked periodically and adjusted to compensate for wear. If the mower has been idle for an extended period of time, or in wet weather, before operating check to be sure the Clutch Plates are not frozen or rusted together. Should this freezing occur, follow this procedure to break the plates loose.

1. Back the Nuts on the Spring Bolts off three complete turns on the stud.
2. Start the tractor engine, and rev the motor up to about half the tractor RPM.
3. Engage the PTO. The Clutch Plates should break loose.
4. Tighten the Nuts so the Spring Bolts are 1-5/16" and finish preparing the mower for operation.

MAINTENANCE

There are two Friction Discs in the Slip Clutch. These should be checked weekly for oil or grease, wearing, and moisture which could cause corrosion on the Drive Plates.

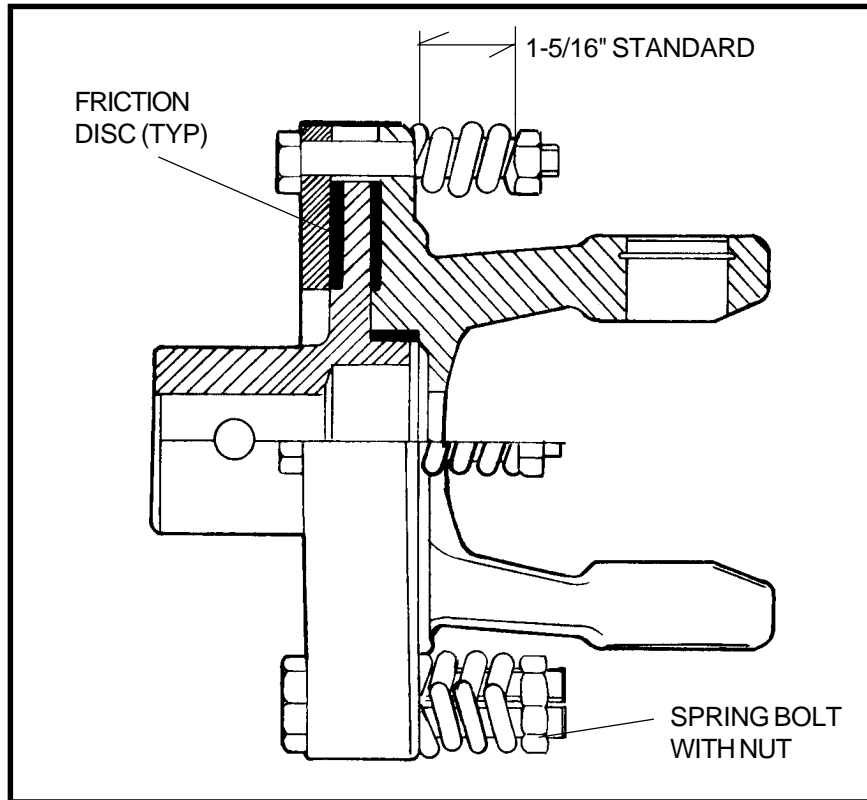

FIGURE 6. Slip Clutch Maintenance

SEASONAL CLUTCH MAINTENANCE

It is important that the clutches slip when an obstacle or load heavier than the clutch setting is encountered. Before using the cutter each season, use the following procedure to make sure the clutch will slip and give the overload protection required.

1. Loosen nuts (1) **Figure 6** until the spring is free, and then retighten approximately one turn.
2. Attach machine to tractor, set engine at approximately half throttle and quickly engage PTO. This procedure will break clutch facings loose and allow the proper torque to be maintained.
3. Return the nuts and bolts to their original position of 1-5/16" compressed spring length. This setting is approximately 1-3/4 turns of the nut after the nut has contacted the spring.

NOTE: If machine sits outside longer than 30 days and is exposed to rain and humid air, the clutches should be removed from machine and stored in dry area. Clutch facings will soak up moisture and cause the metal plates to rust badly. When this occurs, the break-away torque increases greatly and damage to gearbox, driveline, or tractor PTO can occur.

MAINTENANCE

STORAGE

Your rotary cutter represents an investment from which you should get the greatest possible benefit. Therefore, when the season is over, the cutter should be thoroughly checked and prepared for storage so that a minimum amount of work will be required to put it back into operation for the next season. The following are suggested storage procedures:

1. Thoroughly clean the cutter.
2. Lubricate the cutter as covered in Maintenance Section.
3. Tighten all bolts and pins to the recommended torque.
4. Check the cutter for worn or damaged parts. Make replacements immediately.
5. Store the cutter in a clean, dry place with the cutter housing resting on blocks.
6. Use spray touch-up enamel where necessary to prevent rust and maintain the appearance of the cutter.

PROPER TORQUE FOR FASTENERS

The torque chart (**Figure 7**) lists the correct tightening torque for fasteners. When bolts are to be tightened or replaced, refer to this chart to determine the grade of bolts and the proper torque except when specific torque values are assigned in manual text.

RECOMMENDED TORQUE IN FOOT POUNDS (NEWTON-METERS) UNLESS OTHERWISE STATED IN THE MANUAL

NOTE: These values apply to fasteners as received from supplier, dry or when lubricated with normal engine oil. They do not apply if special graphited or molydisulphide greases or other extreme pressure lubricants are used. This applies to both UNF fine and UNC coarse threads.

RECOMMENDED TORQUE IN FT-LBS (Nm) COARSE AND FINE THREADS			
2 (B)  5 (D)  8 (F) 			
Bolt Diameter	Plain Head	Three Dashes	Six Dashes
1/4	Not used	10 (14)	14 (19)
5/16	Not used	20 (27)	30 (41)
3/8	Not used	35 (47)	50 (68)
7/16	35 (47)	55 (75)	80 (108)
1/2	55 (75)	85 (115)	120 (163)
9/16	75 (102)	130 (176)	175 (237)
5/8	105 (142)	170 (230)	240 (325)
3/4	185 (251)	300 (407)	425 (576)
7/8	160 (217)	445 (603)	685 (929)
1	250 (339)	670 (908)	1030 (1396)
1-1/8	330 (447)	910 (1234)	1460 (1979)
1-1/4	480 (651)	1250 (1695)	2060 (2793)

FIGURE 7. Torque Chart

MAINTENANCE

GEARBOX SERVICE INSTRUCTIONS

GEARBOX DISASSEMBLY (Figure 8)

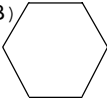
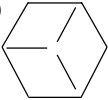
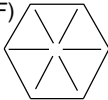
1. Remove 6 capscrews (Ref.#16) from input shaft bearing housing (Ref. #13).
2. Tap around circumference of bearing housing (Ref. #13) to loosen housing and shims. Then (Ref. #9) pull complete shaft and housing assembly (See Fig. 8) out of main housing.
3. Remove 4 capscrews (Ref #18), break gasket loose, and then remove the bearing retainer cap (Ref #2).
4. Output shaft assembly must be removed from main housing by driving or pulling shaft out bottom end.
NOTE: Once lower bearing is out of housing the complete assembly will drop down until top bearing engages lower bearing bore. To complete removal of output shaft assembly it is necessary to keep shaft aligned on center line of housing when removing top bearing out bottom end. Normally the simplest method of removing the output shaft assembly is to attach a slide hammer puller to the shaft and use that to pull the shaft out.

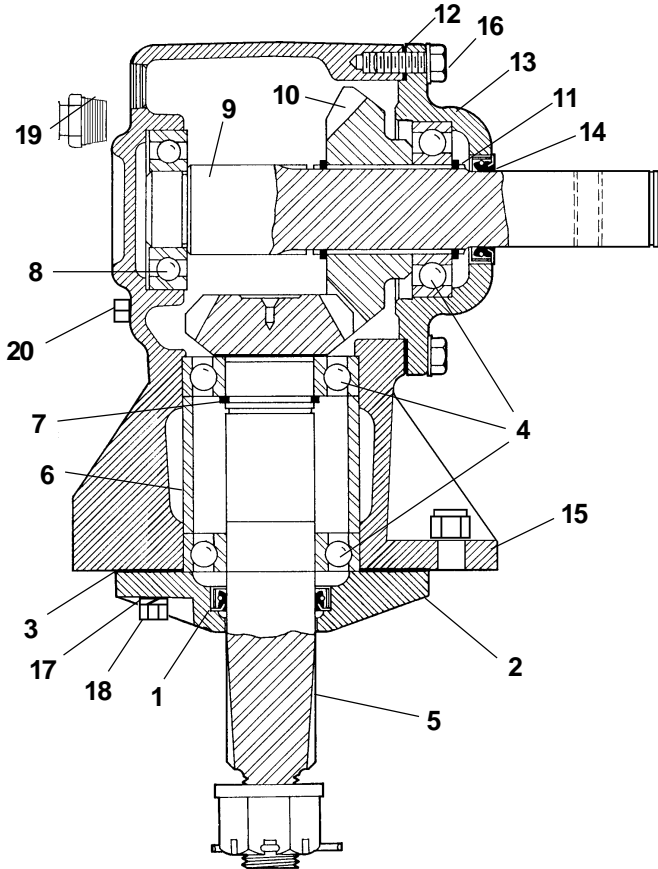

- | | |
|----|---------------------------------|
| 1 | Seal Output Shaft |
| 2 | Cap, Bearing Retainer, (Output) |
| 3 | Gasket, Output, Cap |
| 4 | Bearing, Ball |
| 5 | Shaft, (Output Pinion) |
| 6 | Spacer, Bearing, (Output) |
| 7 | Snap Ring |
| 8 | Bearing, (Input Rear) |
| 9 | Shaft, (Input) |
| 10 | Gear (Input) |
| 11 | Snap Ring |
| 12 | Shim, Side Housing |
| 13 | Housing, Side or Input |
| 14 | Seal, Input |
| 15 | Housing, Main |
| 16 | Bolt, (3/8" x 1") |
| 17 | Lockwasher (3/8") |
| 18 | Bolt, (3/8" x 1-1/4") |
| 19 | Plug, Pipe |
| 20 | Plug, Pipe (1/8" Oil Level) |

FIGURE 8

5. The gearbox is now disassembled into four (4) sub-assemblies:

1. Input shaft assembly
2. Output shaft assembly
3. Lower bearing retainer assembly
4. Main housing assembly

MAINTENANCE

INPUT SHAFT (Figure 9)

DISASSEMBLY AND ASSEMBLY

1. Remove snap ring (Ref. #11) and then remove bearing housing (Ref. #13) by holding end of shaft which does not have a cross hole or splines and tap opposite end of shaft on solid surface. Shock force will remove housing from bearing (Ref.#4).
2. Remove snap ring (Ref. #7) closest to bearing. Tap end of shaft as explained in Step 1 until bearing and gear drop off shaft.
3. Worn components can now be replaced and assembled in reverse order.

ASSEMBLY ORDER

- 1A. Install gear onto shaft as shown in **Figure 9**. Note location of two snap ring grooves.
- 2A. Install bearing on shaft.

NOTE: Use tube with ID just large enough to go over shaft to drive bearing against gear. Install snap ring (Ref 7).

- 3A. Press oil seal flush with front side of bearing housing (See SEAL INSTALLATION RECOMMENDATION).
- 4A. Lubricate ID of seal and insert shaft until bearing contacts housing. Press bearing into housing by hitting end of shaft. Once bearing is in place insert snap ring (Ref #11). **NOTE:** Snap ring must be inserted between bearing and gear before pressing bearing into housing.

SEAL INSTALLATION RECOMMENDATIONS

1. Check Seal - for damage that may have occurred prior to installation. A sealing lip that is turned back, cut or otherwise damaged should be replaced.
2. Check Bore - to see that leading edge is deburred. A rounded corner or chamfer should be provided.
3. Check Shaft - remove surface nicks, burrs and grooves and lubricate with a hard, fibrous grease. **NOTE:** Wrap plastic tape around irregular shaft surfaces such as splines to protect seal during assembly.
4. use Correct Installation Tool - Always use pipe or tube with approximate same OD as seal and press seal by striking tube.

NEVER HAMMER DIRECTLY ON THE SURFACE OF THE SEAL.

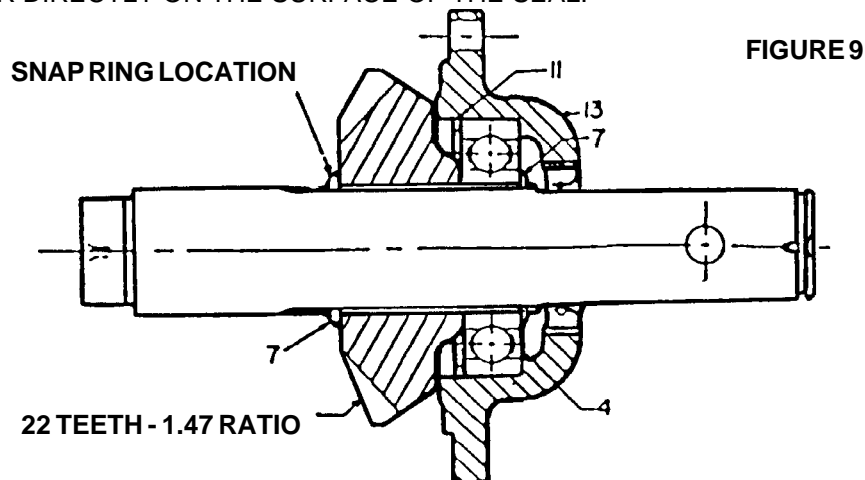

MAINTENANCE

DISASSEMBLY OUTPUT SHAFT (FIG 10)

1. Install slotted nut (Ref 18, **Figure 8**) onto shaft and then tap shaft end on solid surface to remove lower bearing and spacer.
2. remove snap ring (Ref #7) and then repeat above procedure to remove upper bearing.

ASSEMBLY

1A. Assembly of output shaft is accomplished in exact reverse order. Install bearing over shaft and press up against bottom end of gear. Install snap ring (Ref. #7 **Figure 8**).

2A. Install spacer and lower bearing on shaft. **NOTE:** *Bearing Spacer (Ref #6) may be two different lengths and each spacer requires a different bottom cap.*

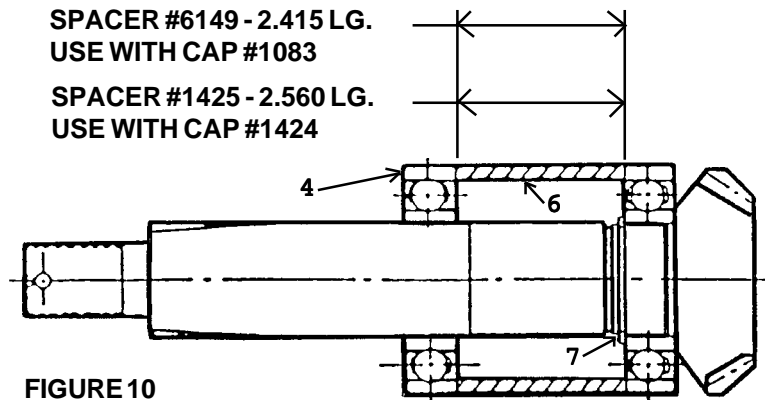

LOWER BEARING RETAINER CAP (Figure 11)

1. Remove old seal from cap and press in new seal. (See SEAL INSTALLATION RECOMMENDATIONS).

Note difference between bearing caps shown to make sure proper part is being used.

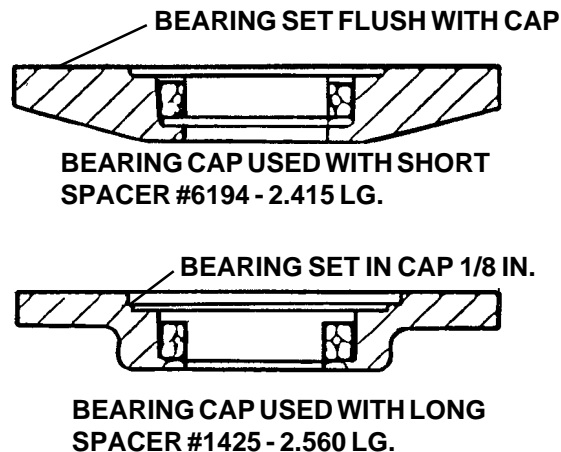

FIGURE 11

MAINTENANCE

MAIN GEARBOX

1. Remove bearing (Ref. #8 **Figure 8**) from inside main housing. A special slide hammer puller (PROTO No. 4056) or equal may be required to remove bearing. Press in new bearing using driving tube or pipe with approximate same OD. as bearing. Seat outer race of bearing against shoulder in housing.

GEARBOX ASSEMBLY STEPS

Clean and scrape all gasket surfaces.

A.

1. Insert output shaft assembly into main housing and press into place. **NOTE:** Use pipe or tube with approximate same OD. as bearing and press into place by striking or pressing on tube.

2. Prelube lower bearing.

3. Place lower gasket in place and then carefully slide bearing retainer cap assembly down shaft.

4. Install bolts and lockwashers and torque to 40-50 ft. lbs.

B.

1. Assemble three shims onto input shaft housing. Insert input shaft assembly into main housing by installing shaft end into bearing in main housing. It may be necessary to rotate shaft to align gear teeth so that housing will install completely.

2. Install washers and bolts and torque to 40-50 ft. lbs.

3. Gear backlash check procedure (**Figure 12**). Install 1/2 x 3 capscrew through shear pin hole. Install flat washers to take up 1/2" space and then install nut and tighten so bolt cannot move. Clamp gearbox to something solid so it will not move when shaft is rotated by hand. Measure 1-1/2 inches from side of shaft to point on bolt and mark (See **Figure 12**). Set dial indicator at marked point, then while holding bottom shaft so it will not rotate, rotate the input shaft back and forth noting extreme indicator reading. If total indicator deflection reading does not fall between .006 to .018, then shims (Ref. #12 **Figure 8**) will have to be added to increase backlash or deleted to decrease backlash.

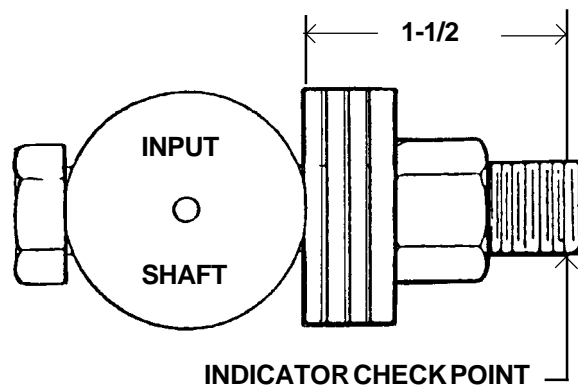

FIGURE 12

PARTS ORDERING GUIDE

The following instructions are offered to help eliminate needless delay and error in processing purchase orders for the equipment in this section.

1. The Parts Section is prepared in logical sequence and grouping of parts that belong to the basic machine featured in this manual. Part Numbers and Descriptions are given to help locate the parts and quantities required.
2. The Purchase Order must include the name and address of the person or organization ordering the parts, who should be charged, and if possible, the serial number of the machine for which the parts are ordered.
3. The Purchase Order must clearly list the quantity of each part, the complete and correct part number, and the basic name of the part.
4. The Manufacturer reserves the right to substitute parts where applicable.
5. Some parts are unlisted items which are special production items not normally stocked and are subject to special handling. Request a quotation for such parts before sending a Purchase Order.
6. The Manufacturer reserves the right to change prices without prior notice.

NOTE: Please refer to The Safety Section in the front of this Manual for the proper PartNumber when ordering Replacement Safety Decals.



For maximum safety and to guarantee optimum product reliability, always use genuine Alamo Parts. The use of inferior replacement parts may cause premature or catastrophic failure which could result in serious injury or death. Direct any questions regarding parts to:



Alamo
P.O. Drawer 549
Seguin, Texas 78156
830-372-3080

PARTS TABLE OF CONTENTS

Tongue Assembly	6-4
Level Rod Assembly	6-5
Dishpan Assembly	6-6
Axle Assembly	6-7
Gearbox Assembly	6-8
Deflectors	6-10
Chain Guard Assemblies	6-11
Driveline Pull Type	6-12
Slipclutch (00762242)	6-13
Driveline Lift Type Slip Clutch	6-14
Driveline Lift Type Shear Bolt	6-15
Three-Point Hitch Assembly	6-16
Offset Adapter	6-17
Tailwheel Assembly	6-18
Hydraulic Relief	6-19

TONGUE ASSEMBLY

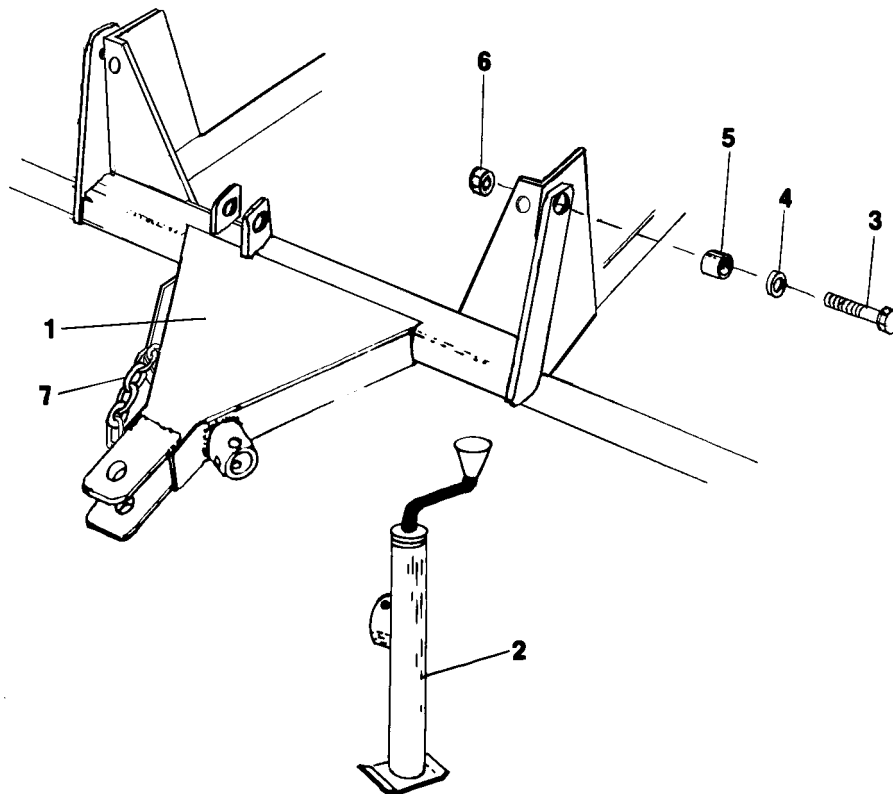

ITEM	PART NO.	QTY	DESCRIPTION
1	00766275	1	Tongue Weldment
2	7092	1	Jack
3	7A114916	2	Bolt
4	15B1400	2	Flatwasher
5	423013	2	Bushing
6	5JRC1490	2	Locknut
7	00764515	1	Chain

LEVEL ROD ASSEMBLY

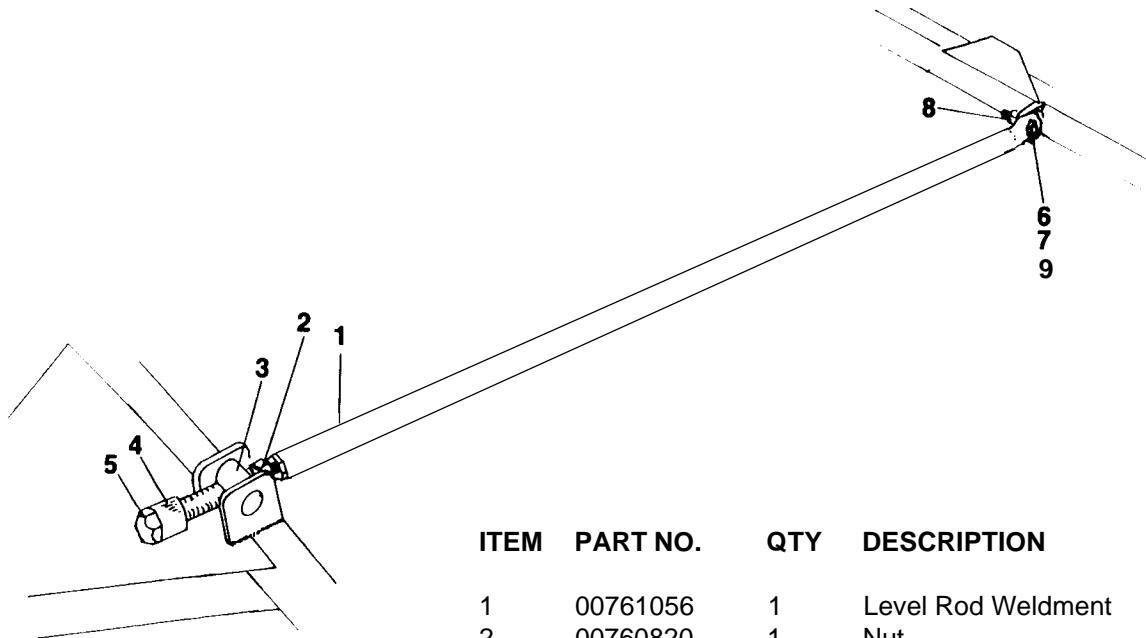

ITEM	PART NO.	QTY	DESCRIPTION
1	00761056	1	Level Rod Weldment
2	00760820	1	Nut
3	00761046	1	Trunion
4	00761267	1	Spacer
5	00761037	1	Adjuster Weldment
6	02931300	1	Bolt
7	511016	1	Bushing
8	00037200	1	Nut
9	15B1200	1	Flatwasher

SAFETY SHIELD ASSEMBLY

ITEM	PART NO.	QTY	DESCRIPTION
1	7541	1	Shield
2	7540	1	Bracket
3	00002700	1	Flatwasher
4	5F8130	1	Wingnut
5	00764259	1	Chain
6	4405	2	Cotter Pin

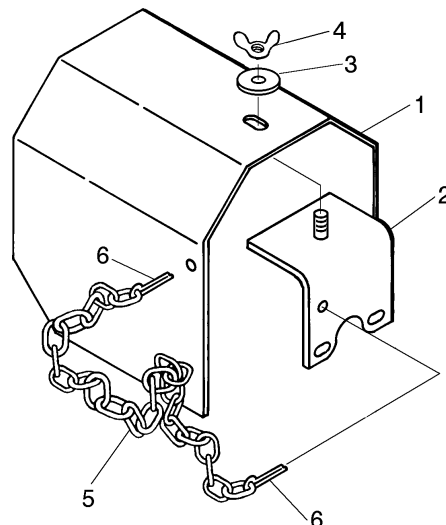

DISH PAN ASSEMBLY P/N00761358

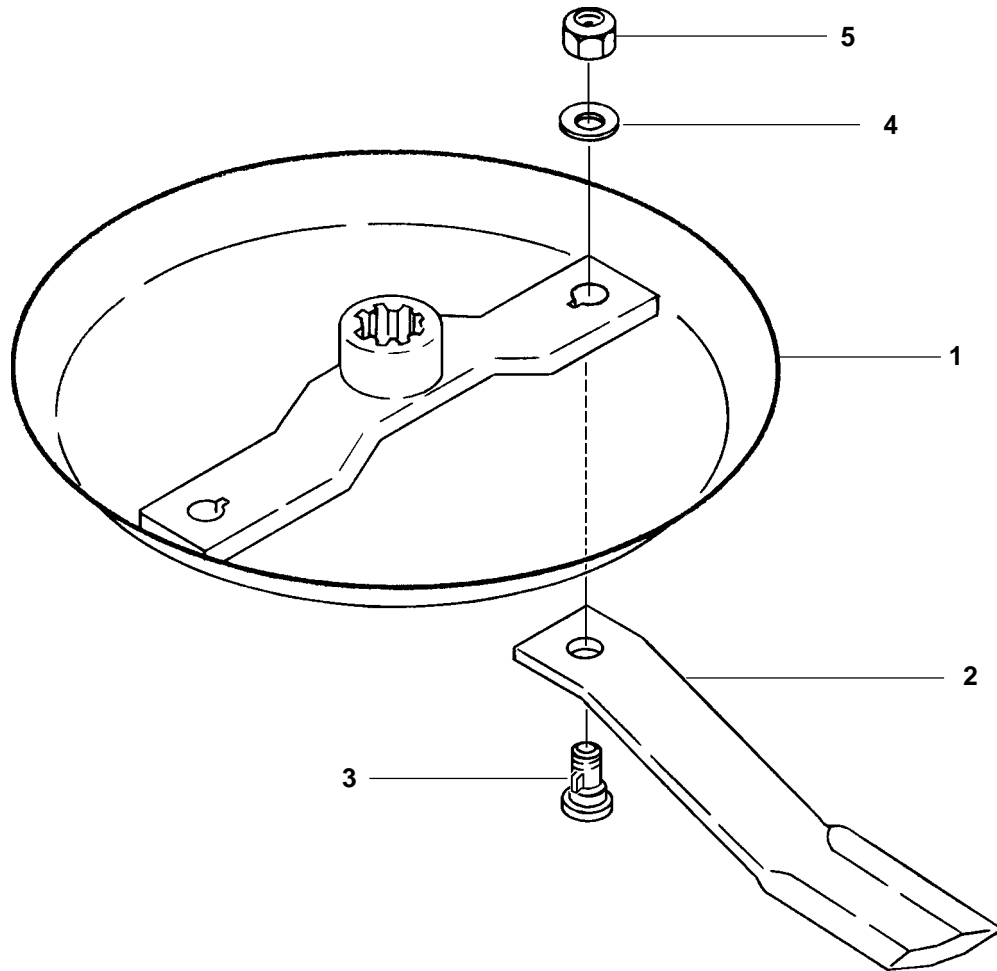

ITEM	PART NO.	QTY.	DESCRIPTION
1	00761357	1	Dish Pan Weldment
2	00761319	2	Suction Blade
3	00761402	2	Blade Bolt
4	00761535	2	Washer
5	00750226	2	Locknut

AXLE ASSEMBLY

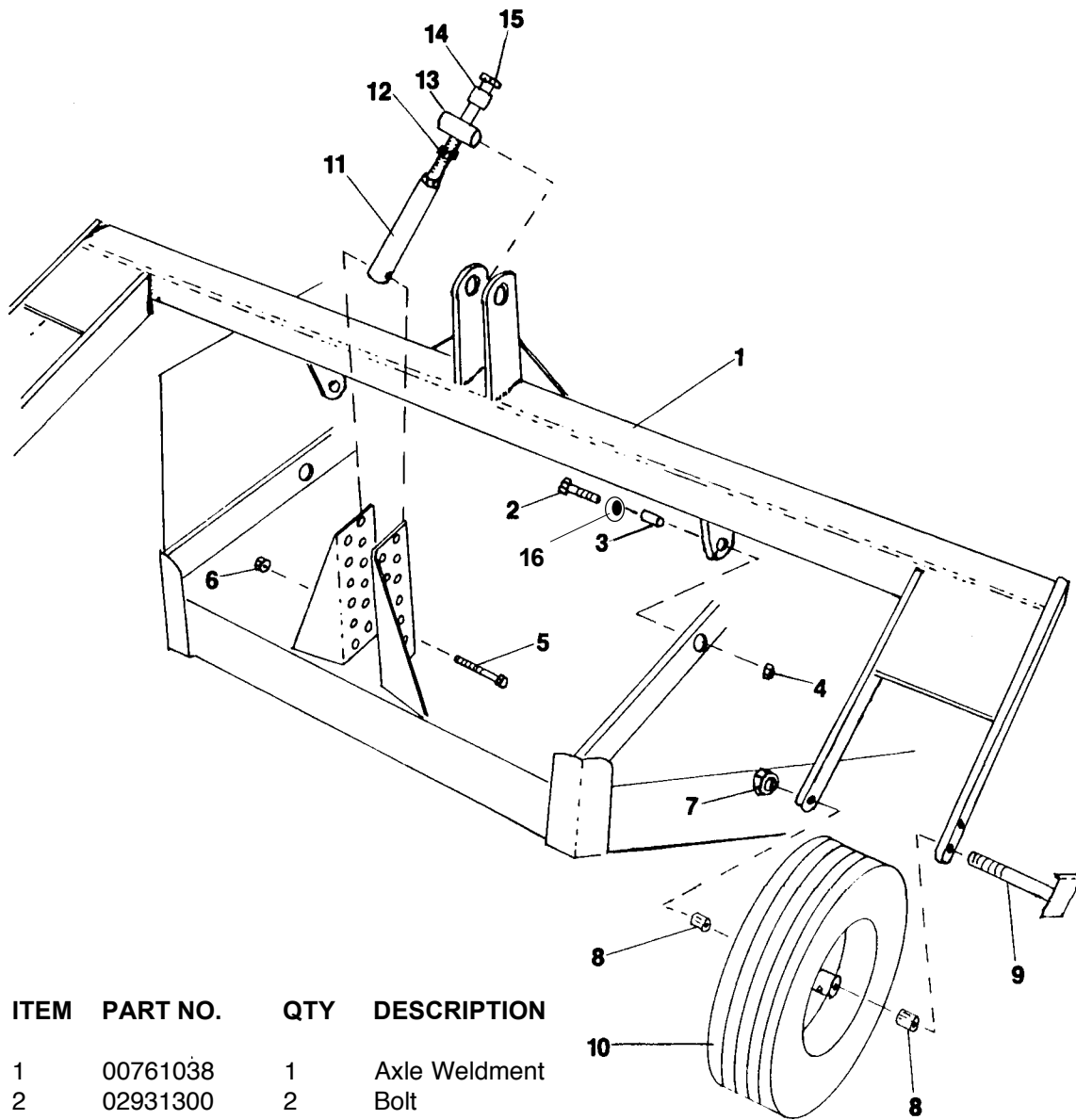

ITEM	PART NO.	QTY	DESCRIPTION
1	00761038	1	Axle Weldment
2	02931300	2	Bolt
3	511016	2	Bushing
4	00037200	2	Nut
5	00753013	1	Bolt
6	00001800	1	Locknut TLM 1/2 NC PLC
7	5JRC16140	2	Nut
8	00765337	4	Spacer
9	0891030300	2	Pin Weldment
10	00756760	2	Wheel & Tire Assy (Semi-Solid)
	0891030200	2	Wheel & Tire Assy (Laminated)
11	00761034	1	Adjuster Support
12	00760820	1	Nut
13	00761046	1	Trunion
14	00761267	1	Spacer
15	00761037	1	Adjuster Weldment
16	15B1200	2	Flatwasher

GEAR BOX ASSEMBLY 0711050100

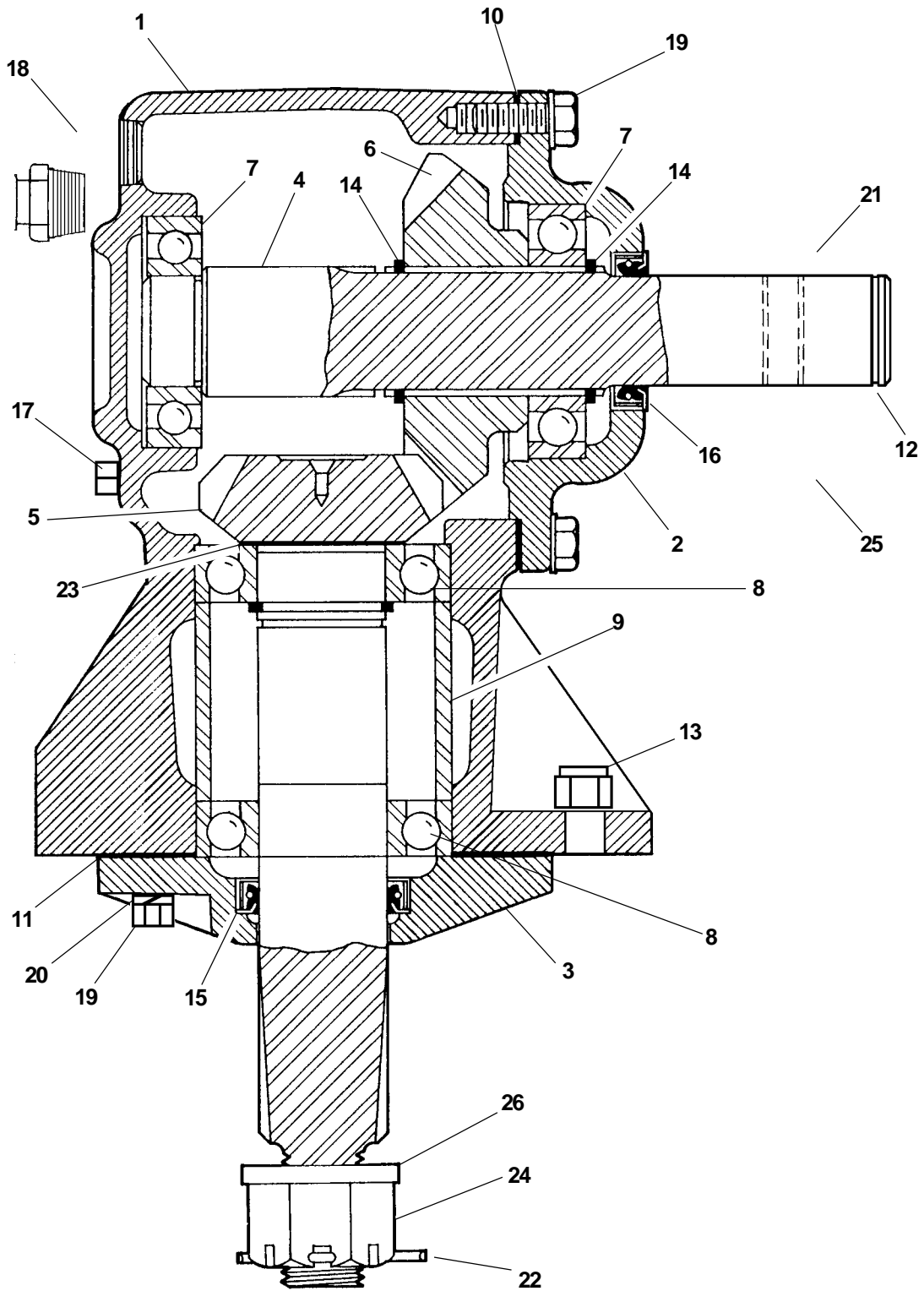

GEAR BOX ASSEMBLY 0711050100

ITEM	PART NO.	QTY	DESCRIPTION
1	00563900	1	Main Housing
2	00764949	1	Front Housing
3	00757683	1	Bearing Retainer Cap
4	00564700	1	Shaft, Input
5	00564000	1	Shaft & Pinion Gear
6	00564600	1	Input Gear
7	00564800	1	Ball Bearing
8	00563700	3	Ball Bearing
9	00757682	1	Bearing Spacer
10	00564400	AR	Shims
11	00760929	AR	Gasket .25
	00760928	AR	Gasket .1
12*	7192	1	Retaining Ring
13	02956948	4	Locknut
14	00564100	3	Retaining Ring
15	00563500	1	Oil Seal
16	00564200	1	Oil Seal
17	00565000	1	Pipe Plug
18	00749508	1	Pipe Plug
19	00011400	6	Bolt
20	02161100	10	Lockwasher-External Tooth
21*	7A81324	1	Bolt (Use Grade 2 Bolt only)
22	00606000	1	Cotter Pin
23	00758671	AR	Shim - Gear
24	7202	1	Hex Slotted Nut
25*	00001800	1	Locknut TLM 1/2 NC PLC
26	6192	1	Flatwasher Special

*Not included w/Gearbox Assembly

DEFLECTORS

FRONT DEFLECTOR Assembly P/N 00758340

ITEM	PART NO.	QTY	DESCRIPTION
1	00758253	1	Flap - Deflector
2	02035800	9	Washer
3	00011100	18	Flatwasher
4	00011400	9	Bolt
5	00015800	9	Locknut

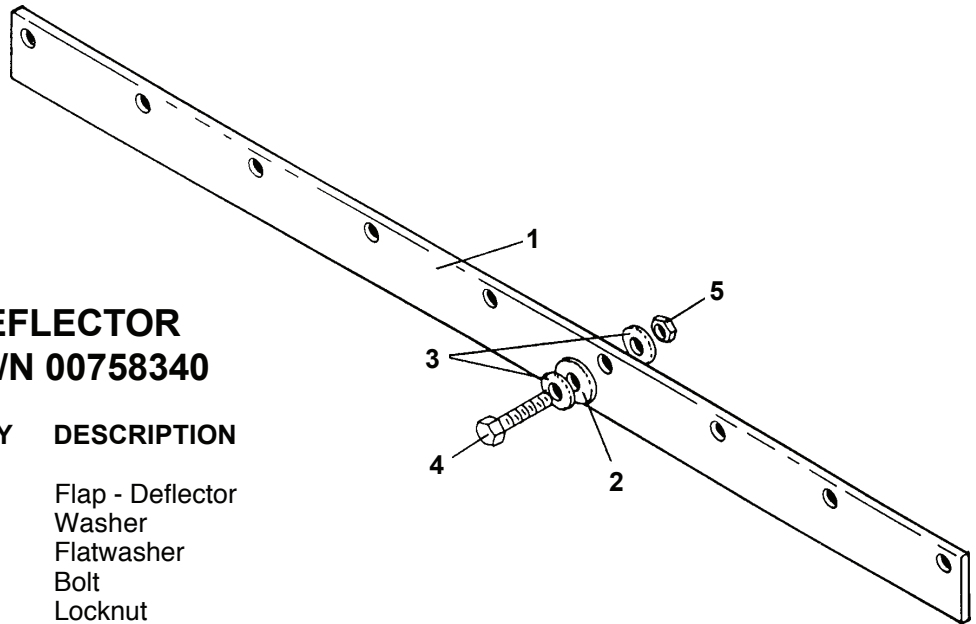

REAR DEFLECTOR Assembly P/N 00761558

ITEM	PART NO.	QTY	DESCRIPTION
1	00761629	1	Deflector (Center)
2	00761633	1	Bar (Center)
3	15B800	6	Washer
4	00750959	6	Hex Head Capscrew
5	00001800	6	Locknut TLM 1/2 NC PLC
6	00761634	2	Bar (Side)
7	00761630	2	Deflector (Side)

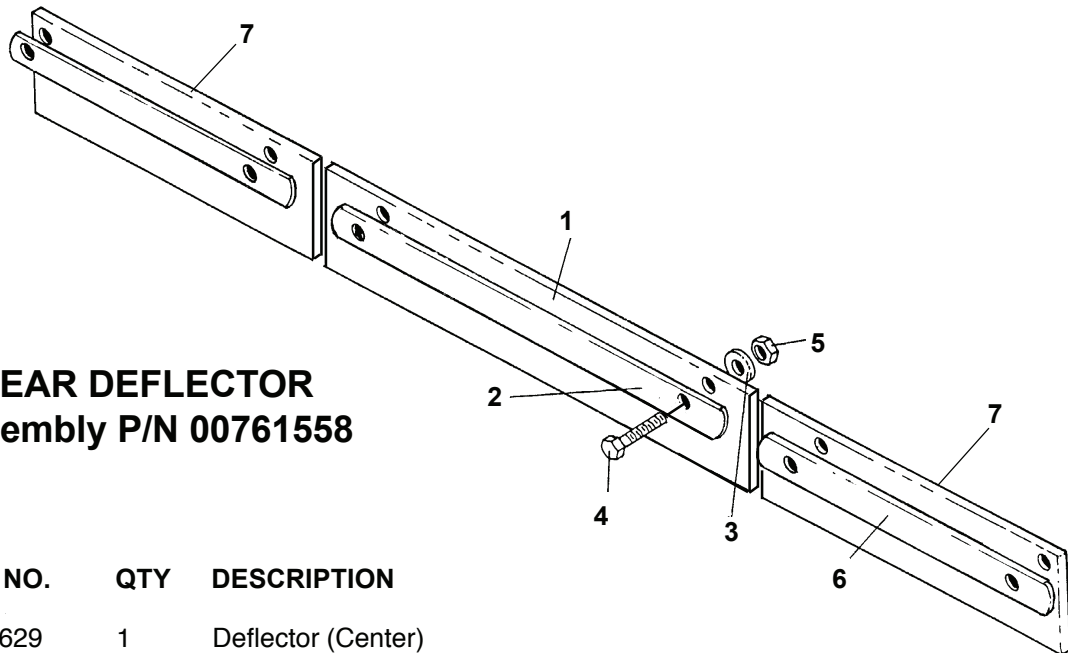

CHAIN GUARD ASSEMBLIES

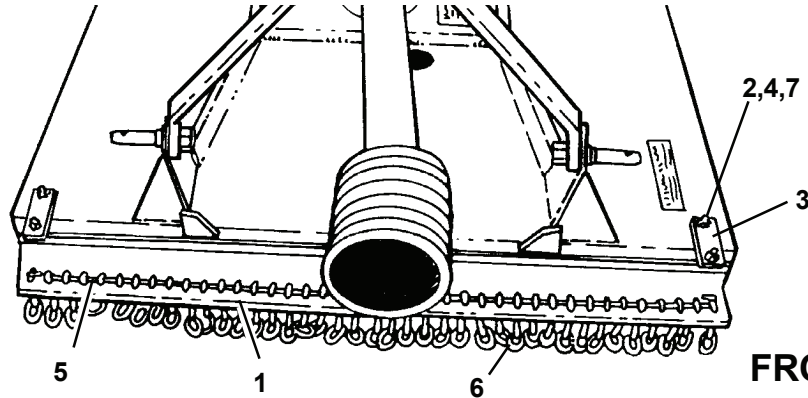

**FRONT CHAIN GUARD
Assembly P/N 0891101000**

ITEM	PART NO.	QTY	DESCRIPTION
1	0891101100	1	Chain Guard Weldment
2	00752680	4	Bolt
3	0901100102	2	Mounting Flat
4	00001800	10	Locknut TLM 1/2 NC PLC
5	0731371001	1	Rod
6	0731361104	51	Chain Links
7	15B800	4	Washers

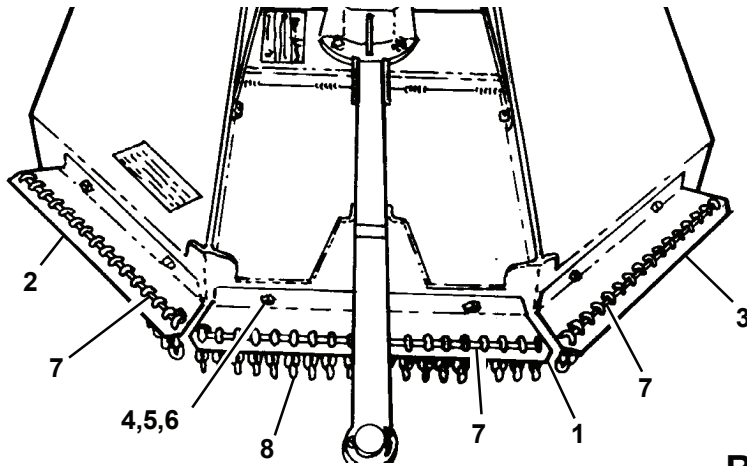

**REAR CHAIN GUARD
Assembly P/N 00761557**

ITEM	PART NO.	QTY	DESCRIPTION
1	00761364	1	Bracket (Center)
2	00761365	1	Bracket (Left)
3	00761366	1	Bracket (Right)
4	00750959	6	Bolt
5	15B800	6	Washer
6	00001800	6	Locknut TLM 1/2 NC PLC
7	00761363	3	Rod
8	0652130101	66	Chain Links

PULL TYPE DRIVELINE P/N 00761057

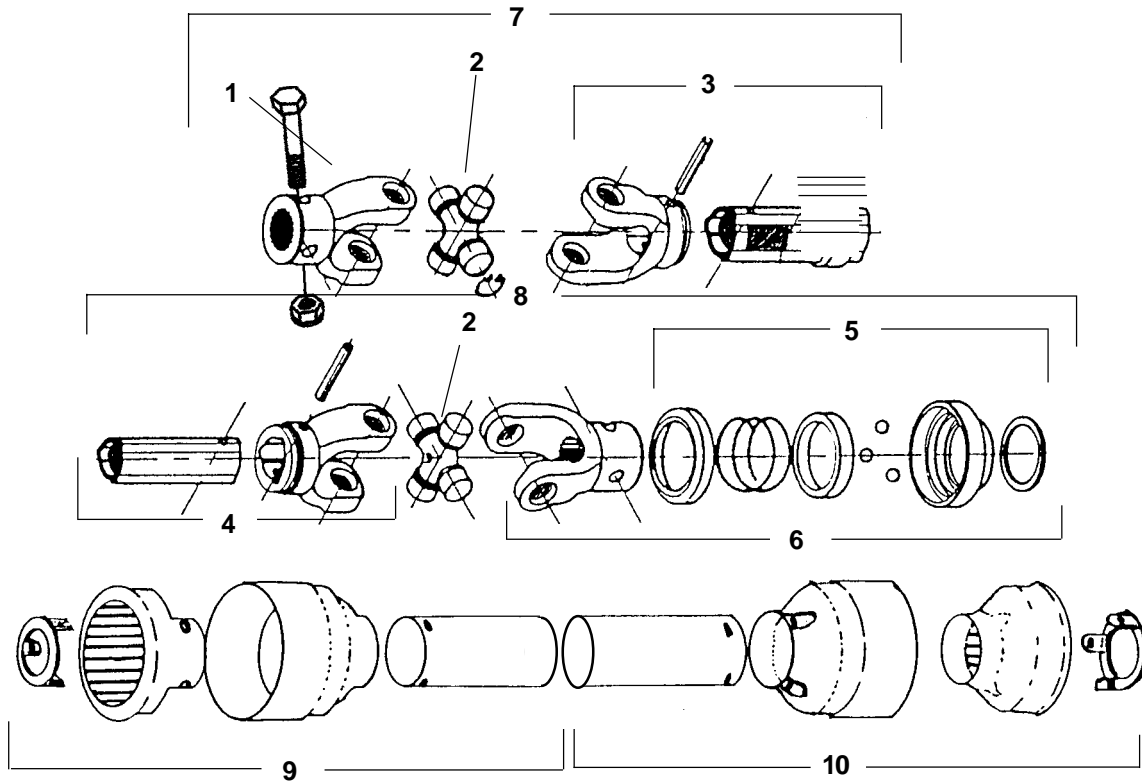

ITEM	PART NO.	QTY	DESCRIPTION
1	00761437	1	Yoke, Shear Pin
2	00761438	2	Cross Journal Set
3	00761439	1	Outer Tube Assembly
4	00761440	1	Inner Tube Assembly
5	00761441	1	Collar Kit
6	00761442	1	Complete Collar Yoke
7	00761443	1	Half Implement Shaft w/Shielding
8	00761444	1	Half Tractor Shaft w/Shielding
9	00761445	1	Half Implement Shield
10	00761446	1	Half Tractor Shield

SLIPCLUTCH (LIFT) P/N 00762242

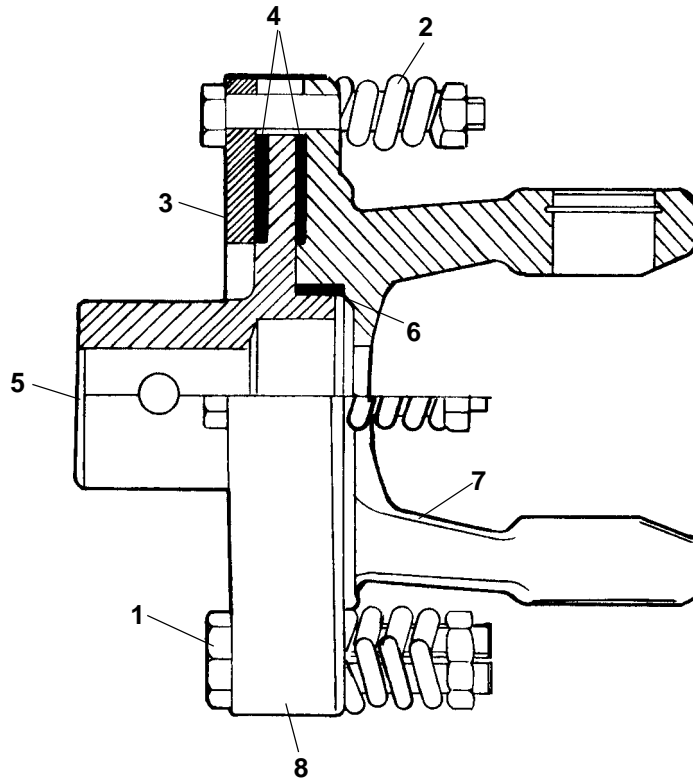

ITEM	PART NO.	QTY	DESCRIPTION
1	00762249	8	Bolt
2	00762250	8	Spring
3	00762247	1	Outer Flange
4	00762248	2	Friction Disc
5	00762243	1	Body - Friction Clutch
6	00762251	1	Spacer
7	00762244	1	Yoke Friction
8	00762252	1	Dirt Shield

LIFT TYPE SLIP CLUTCH DRIVELINE P/N 00759318

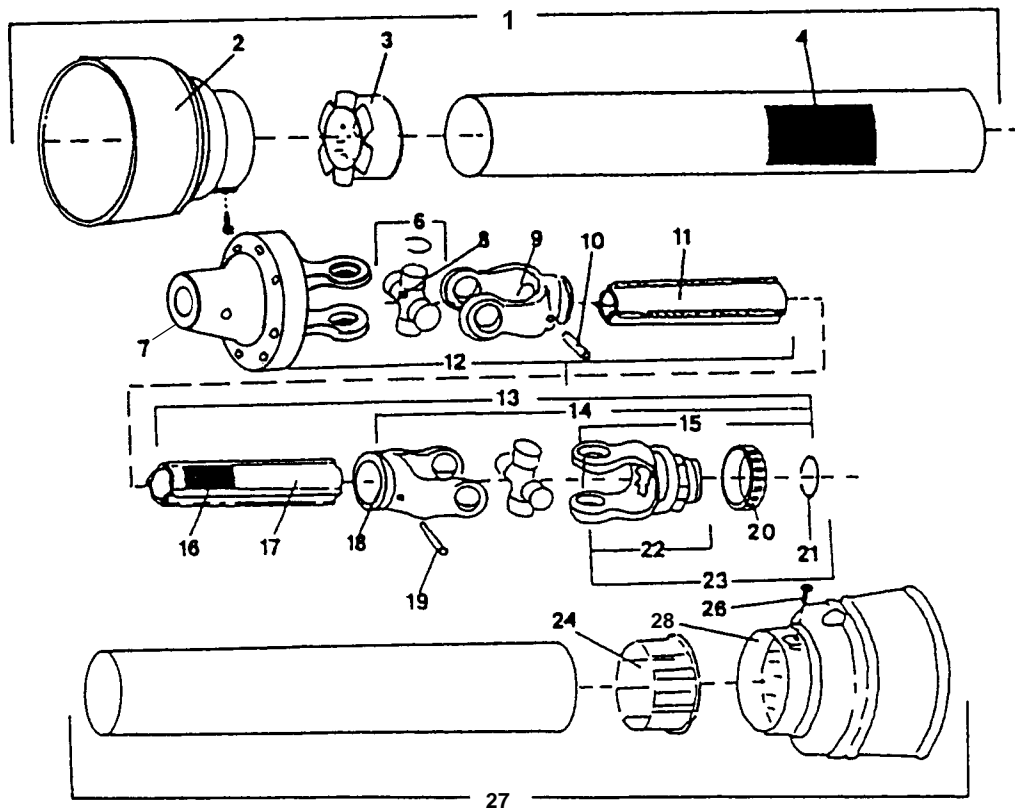

ITEM	PART NO.	QTY	DESCRIPTION
1	00759177	1	Shield Half (Outer)
2	00759526	1	Standard Cone
3	00759527	1	Outer Tube Bearing
4	00756005	1	Driveline Shield Warning Label
6	00756231	2	Cross Assembly
7	00762242	1	Slip Clutch Assembly
8	00759517	2	Grease Fitting
9	00759164	1	Inner Tube Yoke
10	00759165	1	Roll Pin (Inner Tube)
11	00759166	1	Inner Tube
12	00762241	1	Inner Shaft (w/Protector)
13	00759172	1	Outer Shaft (w/Protector)
14	00759521	1	Outer U-Joint
15	00759171	1	Collar Kit
16	00756004	1	Driveline Warning Label
17	00759167	1	Outer Tube
18	00759168	1	Outer Tube Yoke
19	00759169	1	Outer Tube Roll Pin
20	00759516	1	Collar Lock
21	00759515	1	Circlip
22	00754474	1	Push Pin Set
23	00759170	1	Outer Yoke w/Quick Release
24	00759174	1	Inner Tube Bearing
26	00759175	2	Screw
27	00762246	1	Shield Half (Inner)
28	00762245	1	Short Cone

LIFT TYPE SHEAR BOLT DRIVELINE

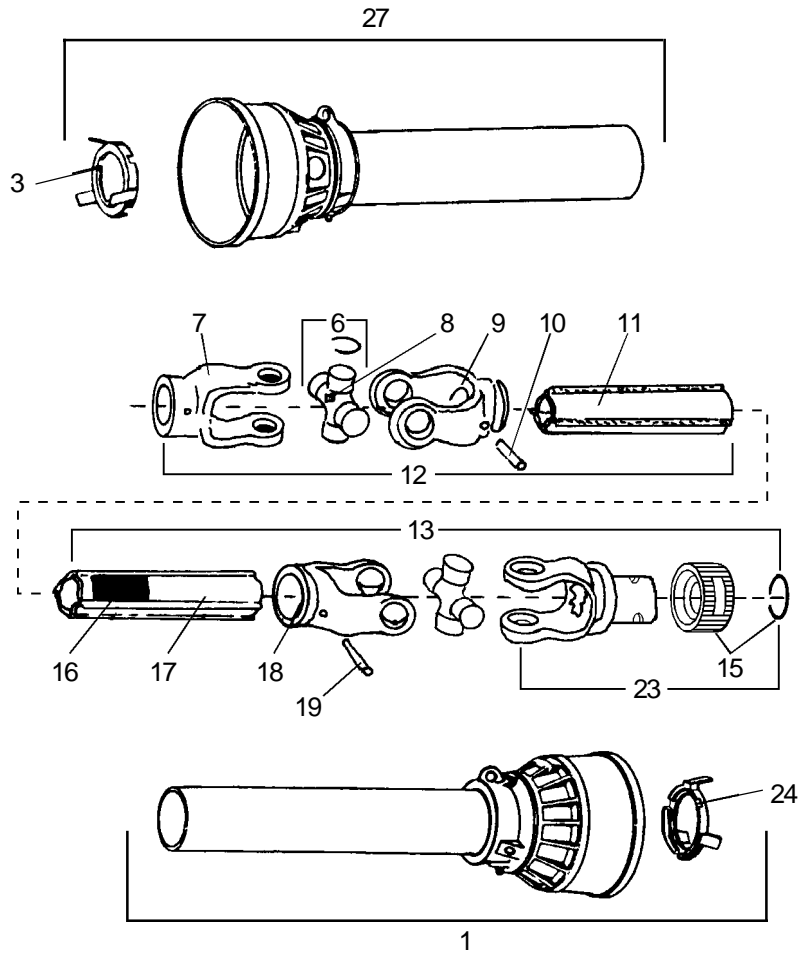

ITEM	PART NO.	QTY	DESCRIPTION
	00759161A	1	Driveline Assy
	00761079A	1	Complete Shield
1	00759920A	1	Shield Half (Outer)
3	00762574	1	Outer Tube Bearing
4	00756005	1	Driveline Shield Warning Label
6	00756231	2	Cross Assembly
7	00759162	1	Outer Yoke (Shear Bolt)
8	00759517	2	Grease Fitting
9	00759164	1	Inner Tube Yoke
10	00759165	1	Roll Pin (Inner Tube)
11	00759913	1	Inner Tube
12	00759173A	1	Inner Shaft (w/Protector)
13	00759915A	1	Outer Shaft (w/Protector)
15	00769592	1	Collar Kit
16	00756004	1	Driveline Warning Label
17	00759914	1	Outer Tube
18	00759168	1	Outer Tube Yoke
19	00759169	1	Outer Tube Roll Pin
23	00769591	1	Outer Yoke w/Quick Release
24	00762577	1	Inner Tube Bearing
27	00761078A	1	Shield Half (Inner)

THREE-POINT HITCH ASSEMBLY

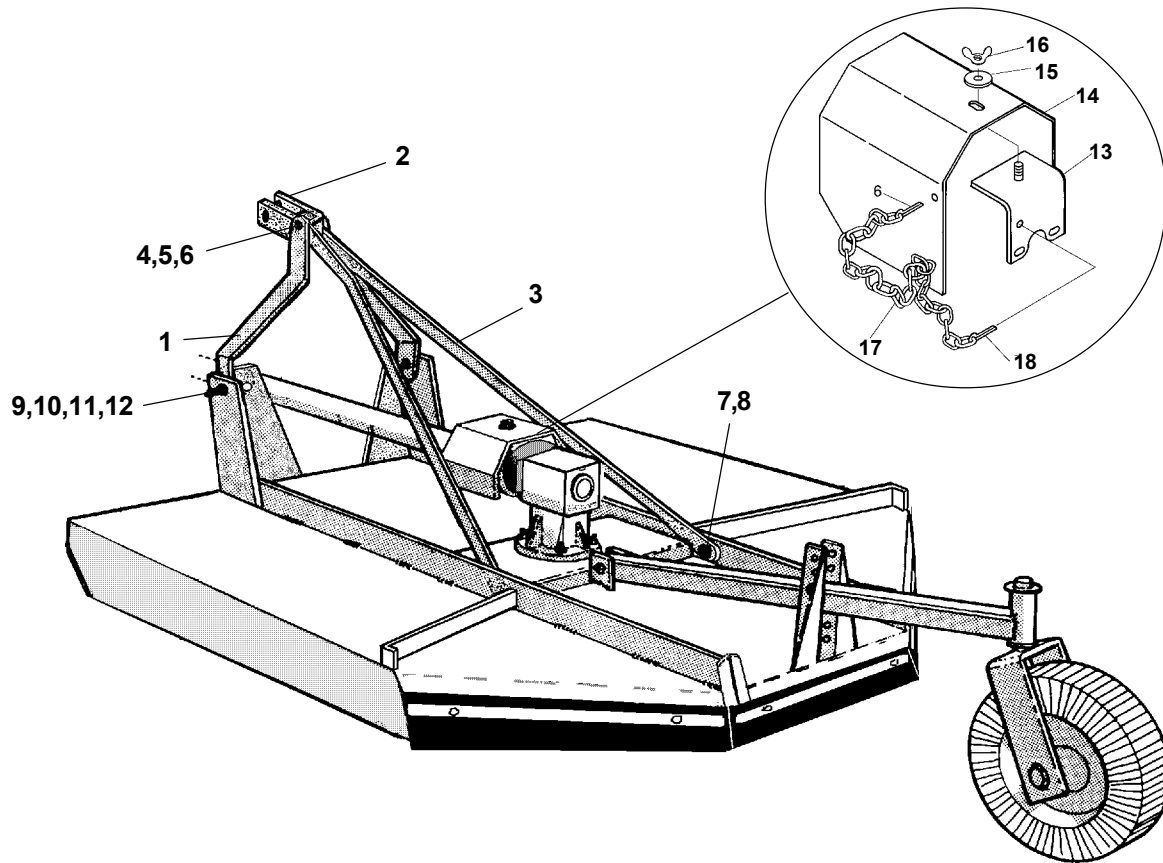

ITEM	PART NO.	QTY	DESCRIPTION
1	00764839	2	"A" Frame Leg
2	00767949	1	Bar Toplink
3	00765331	2	Lift Strap
4	00757953	1	Bushing Spacer
5	02025700	1	Bolt
6	00037200	1	Hex Locknut
7	00001800	3	Locknut TLM 1/2 NC PLC
8	00748823	2	Bolt
9	15B1400	2	Washer, Type "A"
10	00603500	2	Wrist Pin
11	00603600	2	Hex Nut
12	00012200	2	Locknut Washer
13	7540	1	Shield Bracket
14	7541	1	Shield
15	00002700	1	Flatwasher
16	5F8130	1	Wingnut
17	00764259	1	Chain
18	4405	2	Cotter Pin

3-POINT OFFSET ADAPTER P/N 0702310000

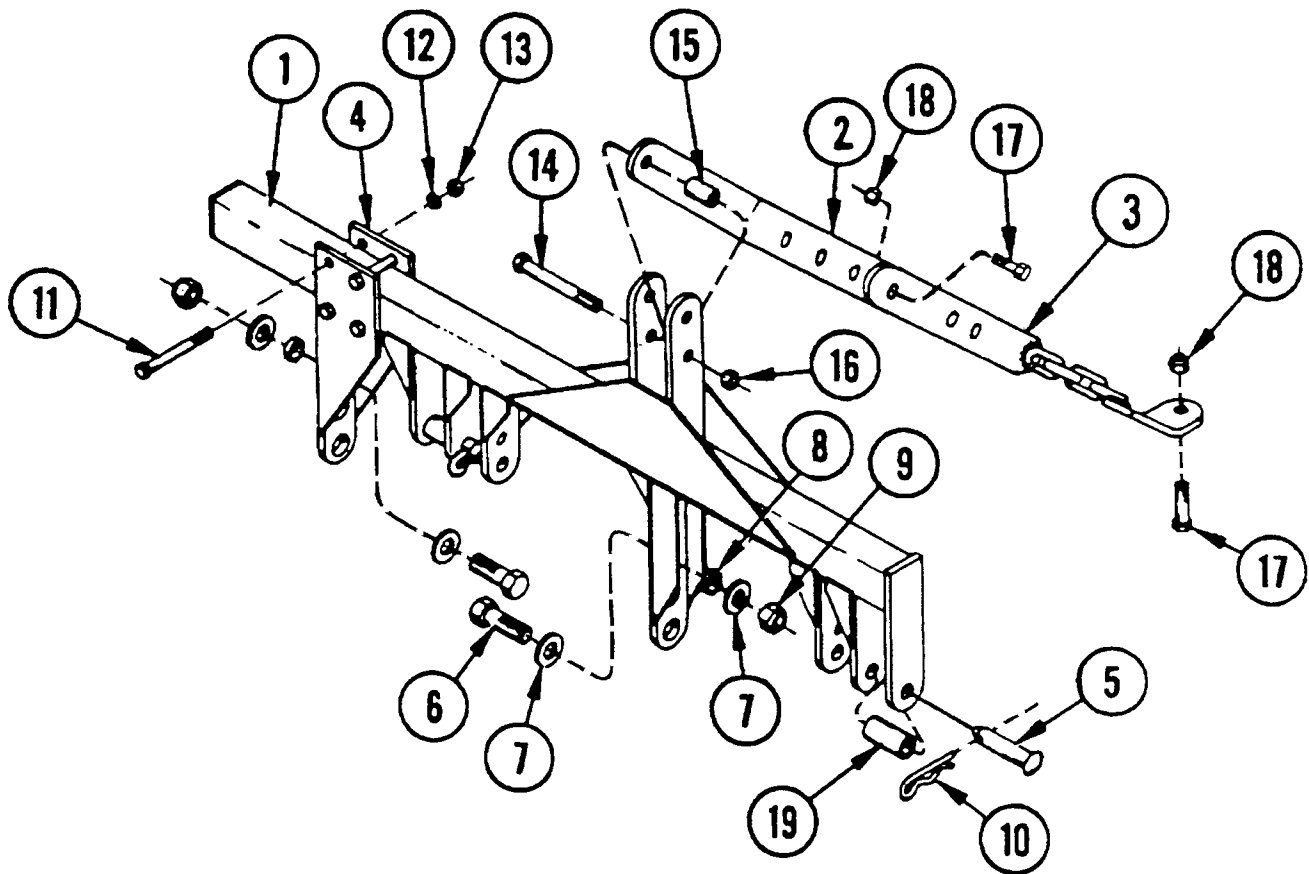

ITEM	PART NO.	QTY	DESCRIPTION
1	0702310100	1	Adapter Mainframe
2	0702310001	1	Brace Bar
3	0702310300	1	Brace Lug and Chain
4	0702310200	1	Adjustable Lift Lug
5	511027	2	Wrist Pin
6	7A14924	2	Bolt
7	15B1400	4	Washer
8	423013	4	Bushing
9	5JRC1490	2	Locknut
10	3W6	2	Retaining Pin
11	02030400	4	Bolt
12	00001300	4	Lockwasher
13	00001200	4	Hex Nut
14	7AH5121636	1	Bolt
15	595062	1	Spacer
16	00748539	1	Locknut
17	7AH5101816	2	Bolt
18	00749136	2	Locknut
19	743013	2	Bushing

TAILWHEEL ASSEMBLY

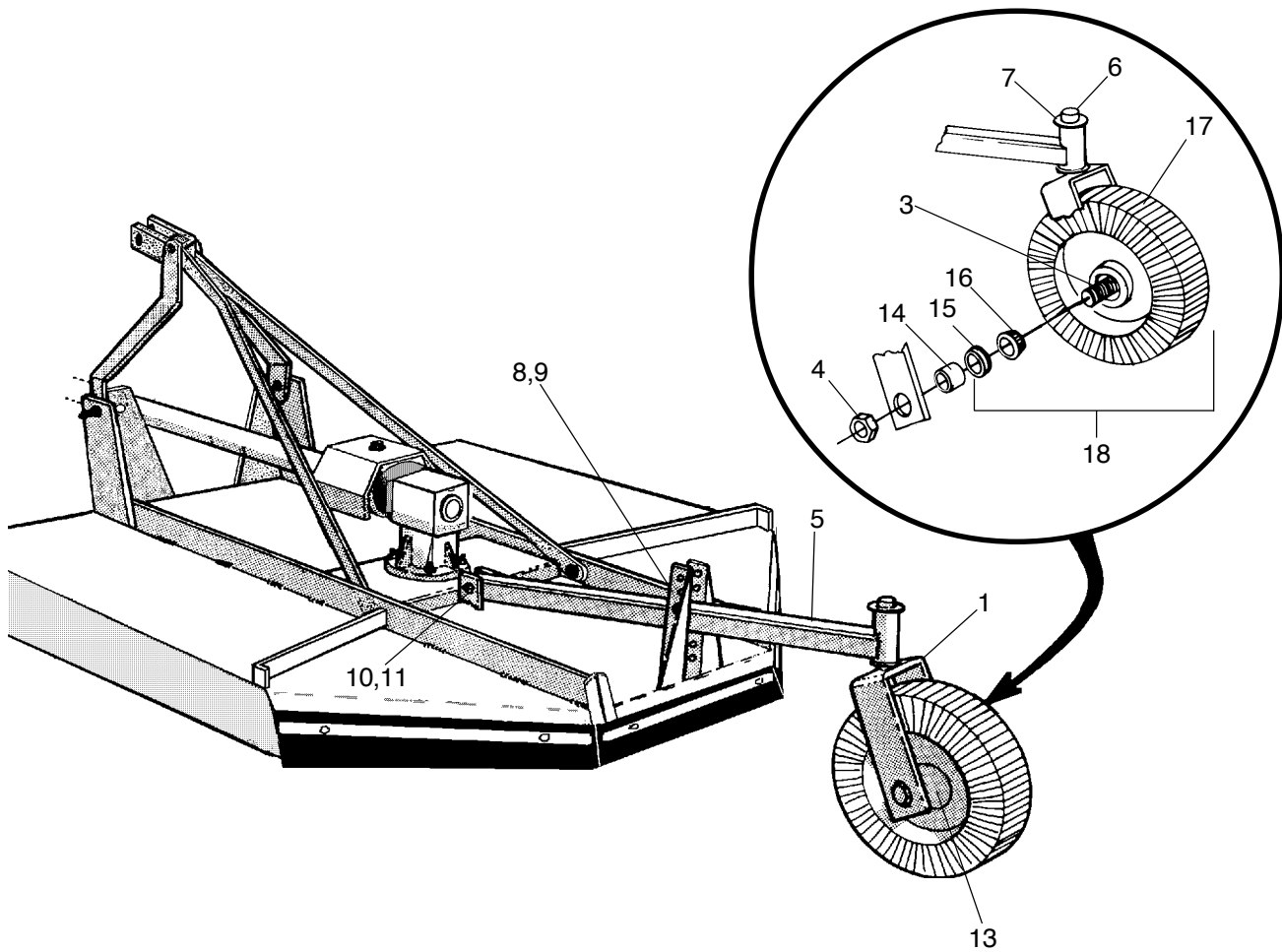

ITEM	PART NO.	QTY	DESCRIPTION
1	0891030100	1	Caster Fork Weldment
3	0891030300	1	Spindle Bolt Weldment
4	5JRC16140	1	Locknut
5	0891020100	1	Tailwheel Beam Weldment
6	00036900	1	Cotter Pin
7	15B2000	1	Type "A" Washer
8	10318000	2	Hex Hd. Capscrew
9	00001800	2	Locknut TLM 1/2 NC PLC
10	00750311	1	Hex Hd. Capscrew
11	00695100	1	Nut, Toplock 5/8 NC PLC
13	02961453	1	Grease Fitting
14	00765337	2	Spacer - Wheel Hub
15	00013600	2	Seal
16	00013701	2	Bearing
17	00756750	1	Tire and Wheel 4 x 8 w/cups
18	000130010	1	Complete Wheel Assembly (includes items 15 thru 17)

HYDRAULIC RELIEF ASSEMBLY P/N 3570

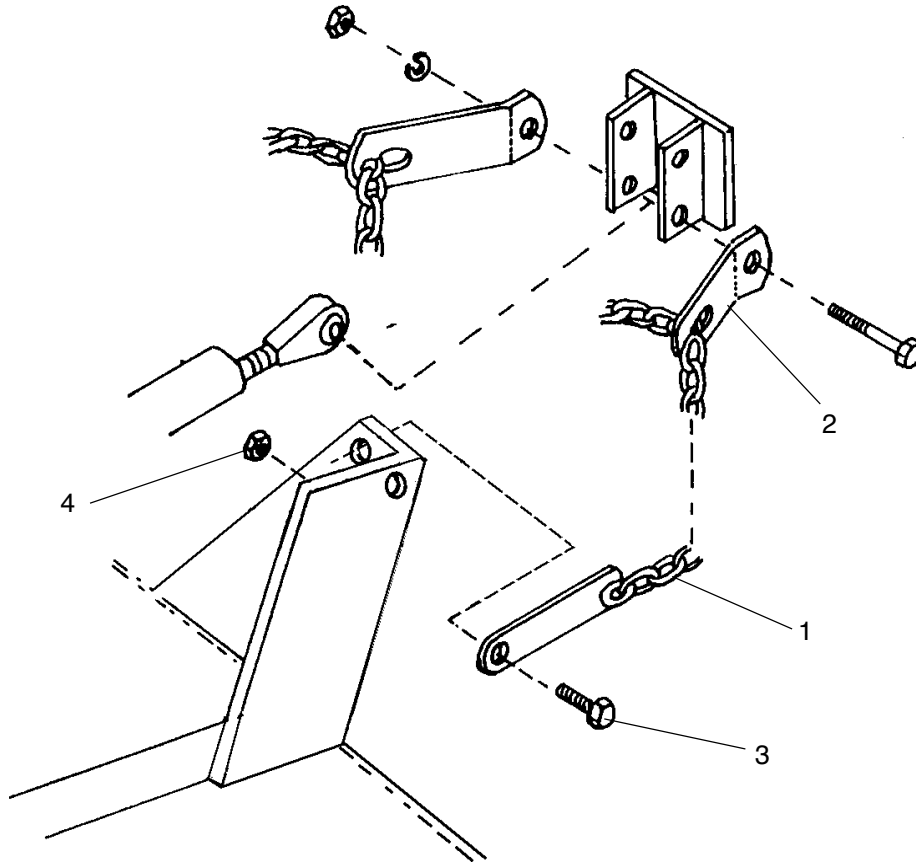

ITEM	PART NO.	QTY	DESCRIPTION
1	8709	2	Chain Assembly
2	8708	2	Bracket
3	02845500	2	Bolt
4	00695100	2	Nut, Toplock 5/8 NC PLC

PARTS TABLE OF CONTENTS

Tongue Assembly	6-4
Level Rod Assembly	6-6
Dishpan Assembly	6-7
Discontinued - Dishpan Assembly	6-8
Axle Assembly	6-9
Gearbox Assembly	6-10
Deflectors	6-12
Chain Guard Assemblies	6-13
Discontinued - Rear Deflector & Rear Chain Guard	6-14
Driveline Pull Type	6-15
Slipclutch (00762242)	6-16
Driveline Lift Type Slip Clutch	6-17
Driveline Lift Type Shear Bolt	6-18
Discontinued - Driveline Lift Type	6-20
Driveline Lift Type	6-21
Slip Clutch (8910)	6-22
Three-Point Hitch Assembly	6-23
Offset Adapter	6-25
Tailwheel Assembly	6-26
Hydraulic Relief	6-27

TONGUE ASSEMBLY

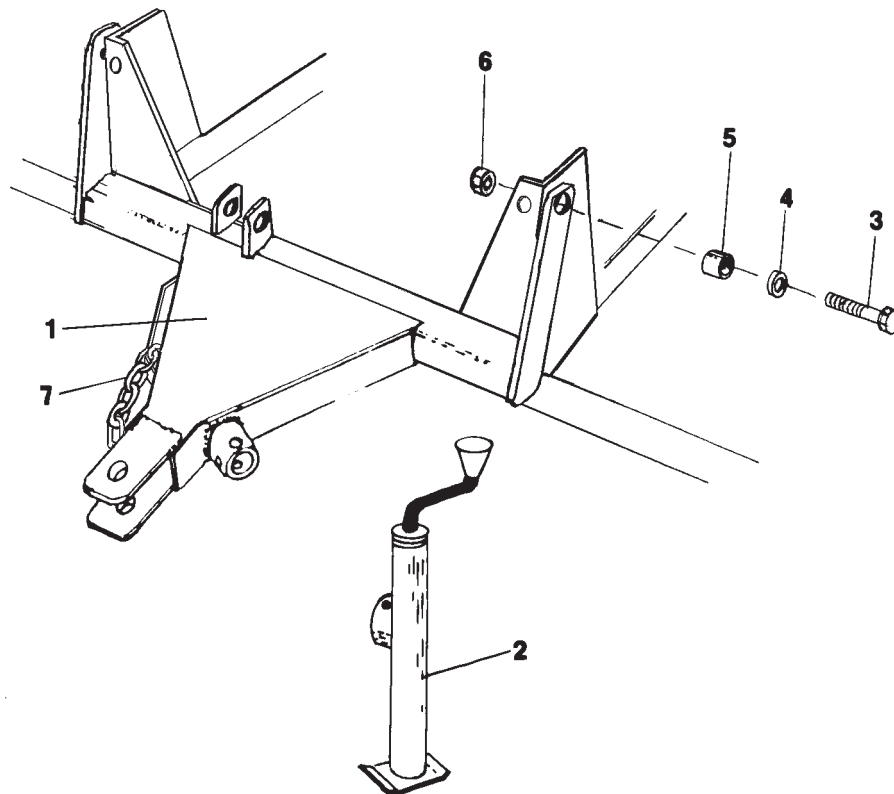

ITEM	PART NO.	QTY	DESCRIPTION
1	00766275	1	Tongue Weldment
2	7092	1	Jack
3	7A114916	2	Bolt
4	15B1400	2	Flatwasher
5	423013	2	Bushing
6	5JRC1490	2	Locknut
7	00764515	1	Chain

LEVEL ROD ASSEMBLY

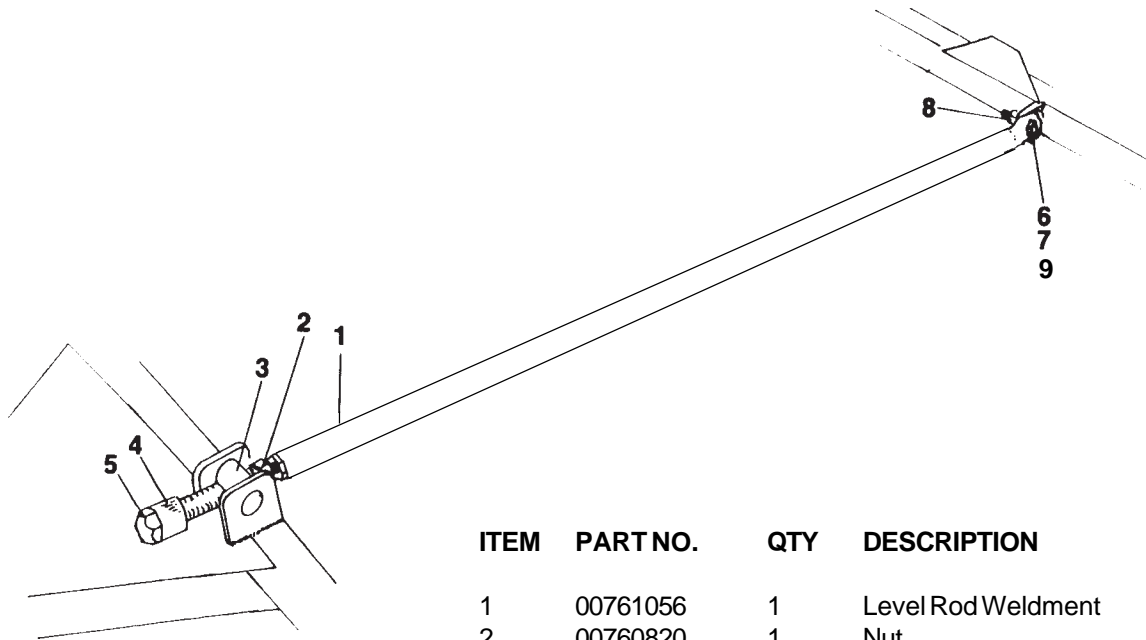

ITEM	PART NO.	QTY	DESCRIPTION
1	00761056	1	Level Rod Weldment
2	00760820	1	Nut
3	00761046	1	Trunion
4	00761267	1	Spacer
5	00761037	1	Adjuster Weldment
6	02931300	1	Bolt
7	511016	1	Bushing
8	00037200	1	Nut
9	15B1200	1	Flatwasher

SAFETY SHIELD ASSEMBLY

ITEM	PART NO.	QTY	DESCRIPTION
1	7541	1	Shield
2	7540	1	Bracket
3	00002700	1	Flatwasher
4	5F8130	1	Wingnut
5	00764259	1	Chain
6	4405	2	Cotter Pin

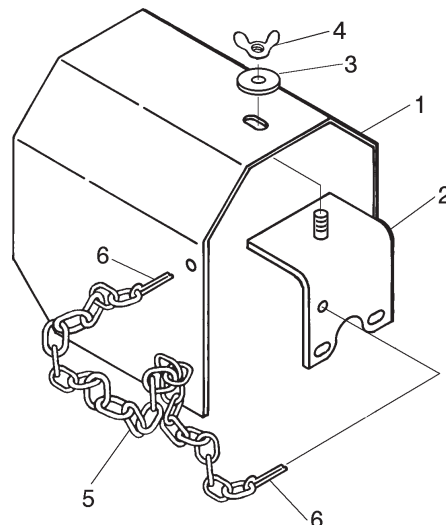

DISH PAN ASSEMBLY P/N00761358

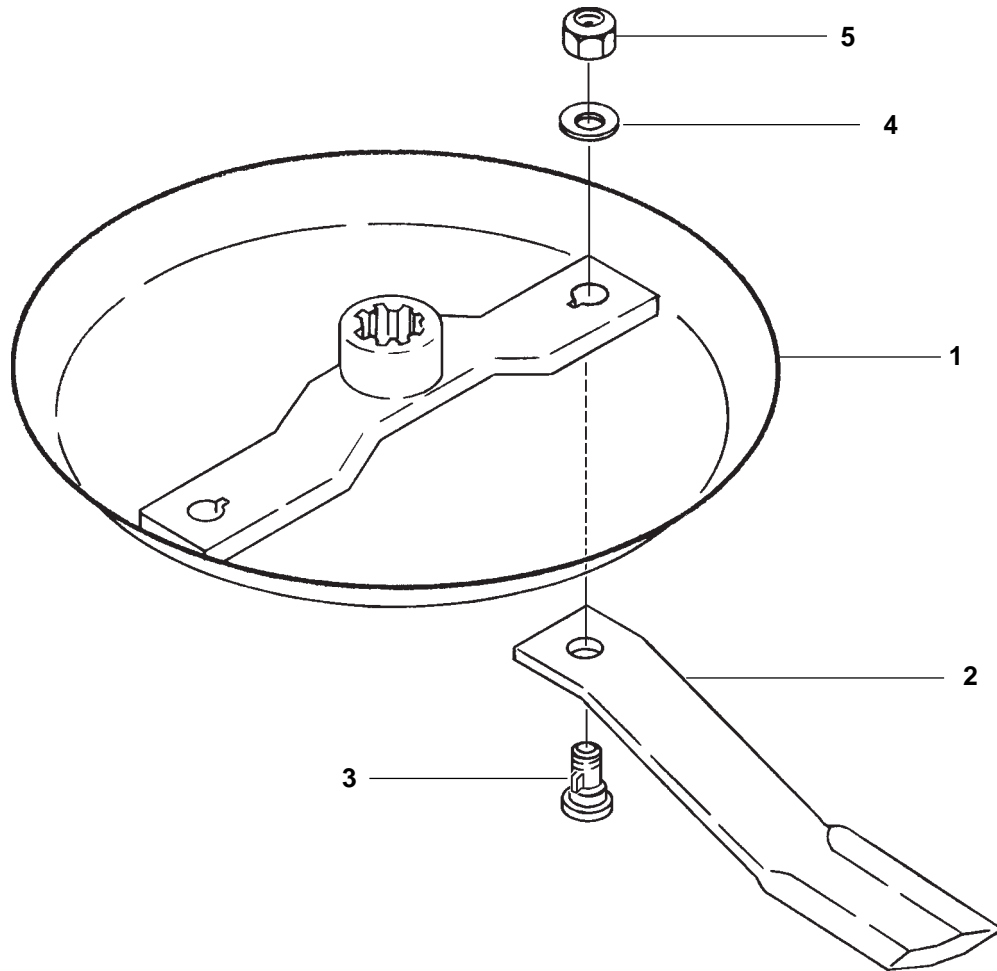

ITEM	PART NO.	QTY.	DESCRIPTION
1	00761357	1	Dish Pan Weldment
2	00761319	2	Suction Blade
3	00761402	2	Blade Bolt
4	00761535	2	Washer
5	00750226	2	Locknut

AXLE ASSEMBLY

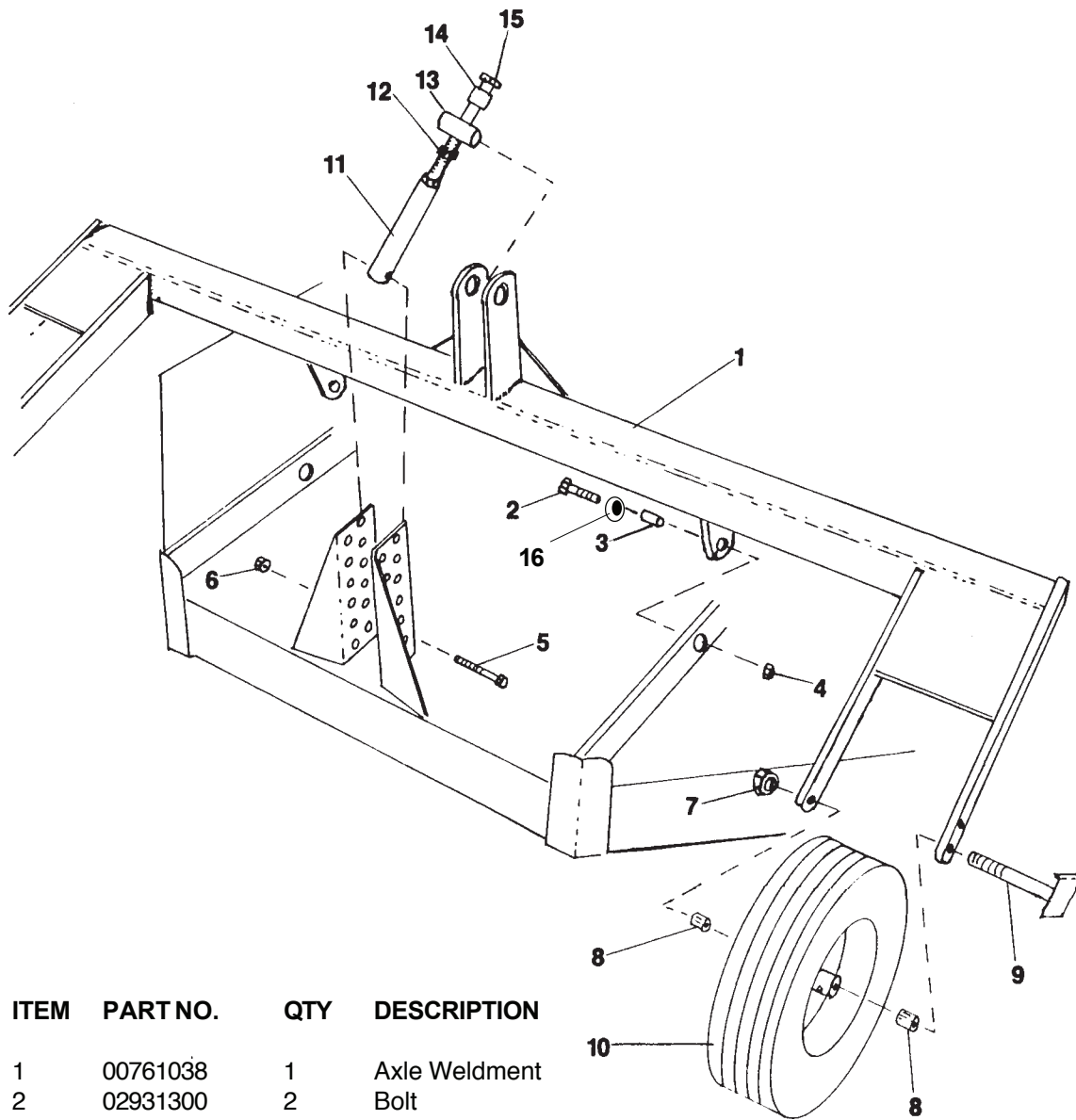

ITEM	PART NO.	QTY	DESCRIPTION
1	00761038	1	Axle Weldment
2	02931300	2	Bolt
3	511016	2	Bushing
4	00037200	2	Nut
5	00753013	1	Bolt
6	00001800	1	Locknut TLM 1/2 NC PLC
7	5JRC16140	2	Nut
8	00765337	4	Spacer
9	0891030300	2	Pin Weldment
10	00756760	2	Wheel & Tire Assy (Semi-Solid)
	0891030200	2	Wheel & Tire Assy (Laminated)
11	00761034	1	Adjuster Support
12	00760820	1	Nut
13	00761046	1	Trunion
14	00761267	1	Spacer
15	00761037	1	Adjuster Weldment
16	15B1200	2	Flatwasher

GEAR BOX ASSEMBLY 0711050100

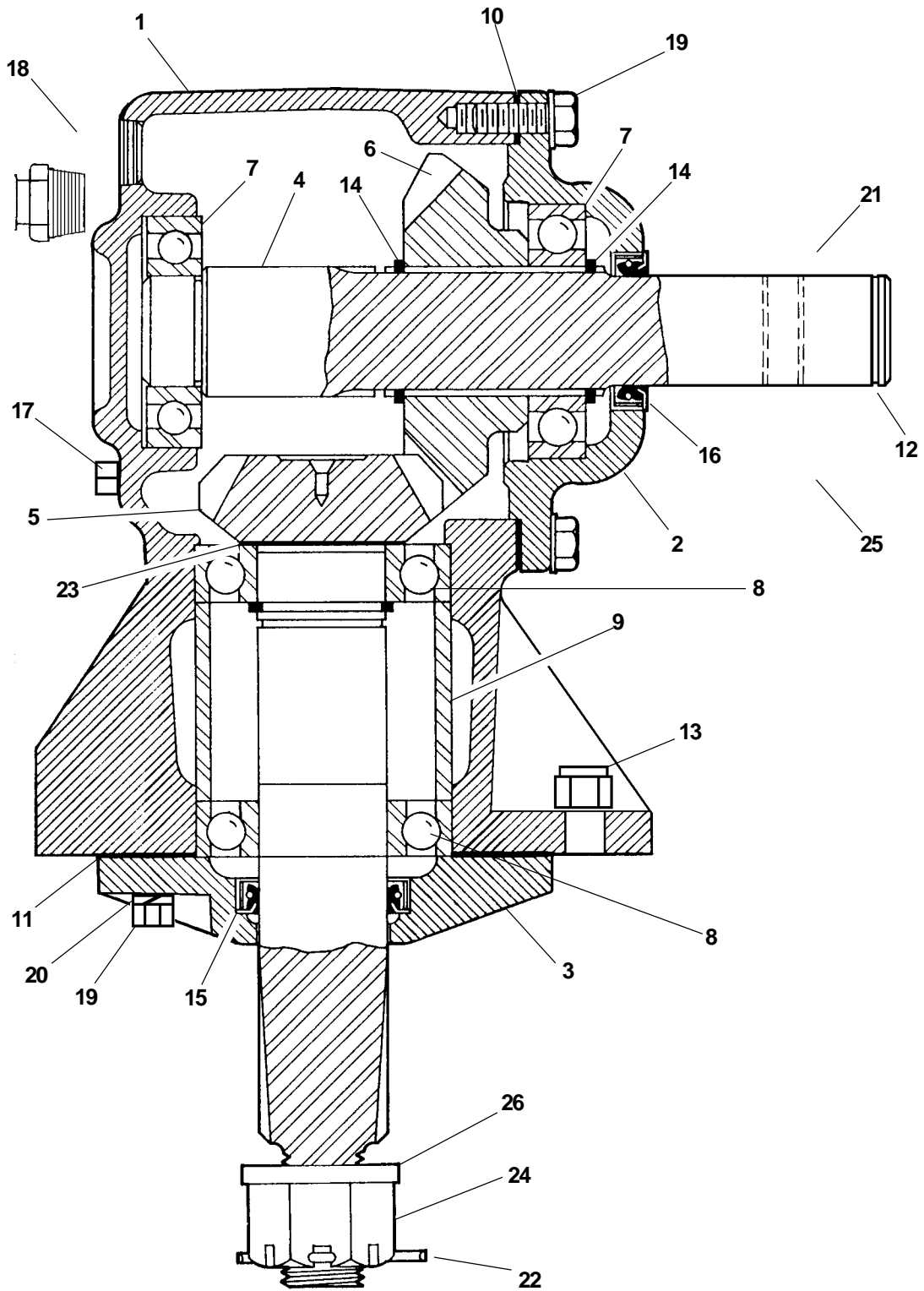

GEAR BOX ASSEMBLY 0711050100

ITEM	PART NO.	QTY	DESCRIPTION
1	00563900	1	Main Housing
2	00764949	1	Front Housing
3	00757683	1	Bearing Retainer Cap
4	00564700	1	Shaft, Input
5	00564000	1	Shaft & Pinion Gear
6	00564600	1	Input Gear
7	00564800	1	Ball Bearing
8	00563700	3	Ball Bearing
9	00757682	1	Bearing Spacer
10	00564400	AR	Shims
11	00760929	AR	Gasket .25
	00760928	AR	Gasket .1
12*	7192	1	Retaining Ring
13	02956948	4	Locknut
14	00564100	3	Retaining Ring
15	00563500	1	Oil Seal
16	00564200	1	Oil Seal
17	00565000	1	Pipe Plug
18	00749508	1	Pipe Plug
19	00011400	6	Bolt
20	02161100	10	Lockwasher-External Tooth
21*	7A81324	1	Bolt (Use Grade 2 Bolt only)
22	00606000	1	Cotter Pin
23	00758671	AR	Shim - Gear
24	7202	1	Hex Slotted Nut
25*	00001800	1	Locknut TLM 1/2 NC PLC
26	6192	1	Flatwasher Special

*Not included w/Gearbox Assembly

DEFLECTORS

FRONT DEFLECTOR Assembly P/N 00758340

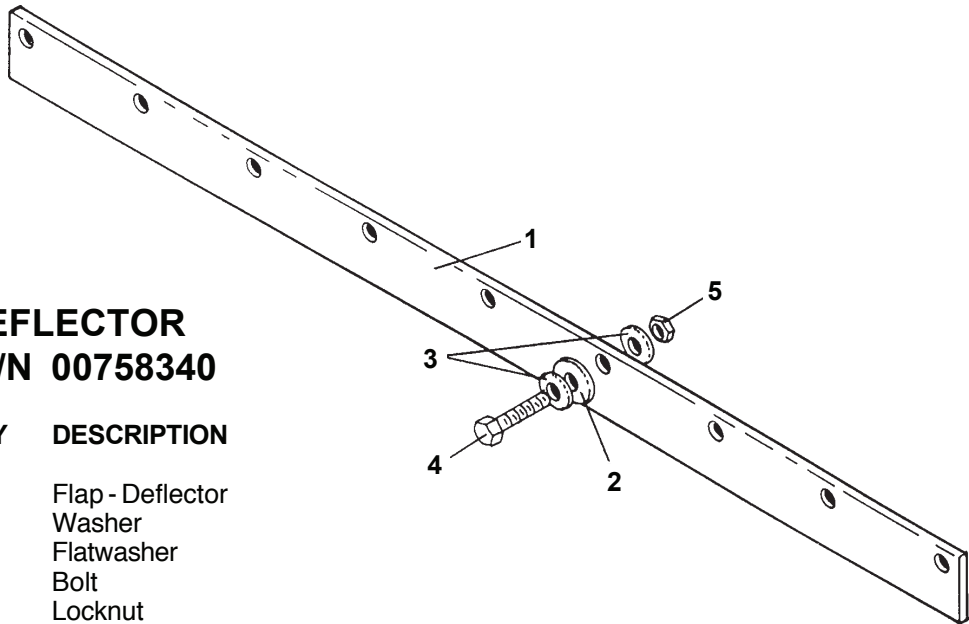

ITEM	PART NO.	QTY	DESCRIPTION
1	00758253	1	Flap - Deflector
2	02035800	9	Washer
3	00011100	18	Flatwasher
4	00011400	9	Bolt
5	00015800	9	Locknut

REAR DEFLECTOR Assembly P/N 00761558

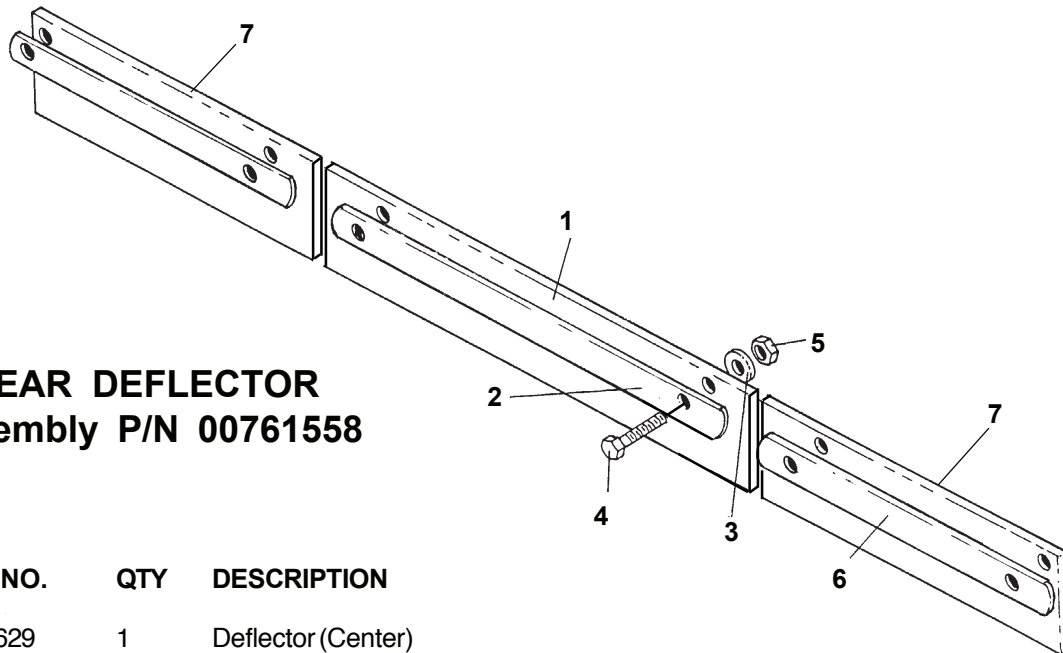

ITEM	PART NO.	QTY	DESCRIPTION
1	00761629	1	Deflector (Center)
2	00761633	1	Bar (Center)
3	15B800	6	Washer
4	00750959	6	Hex Head Capscrew
5	00001800	6	Locknut TLM 1/2 NC PLC
6	00761634	2	Bar (Side)
7	00761630	2	Deflector (Side)

CHAIN GUARD ASSEMBLIES

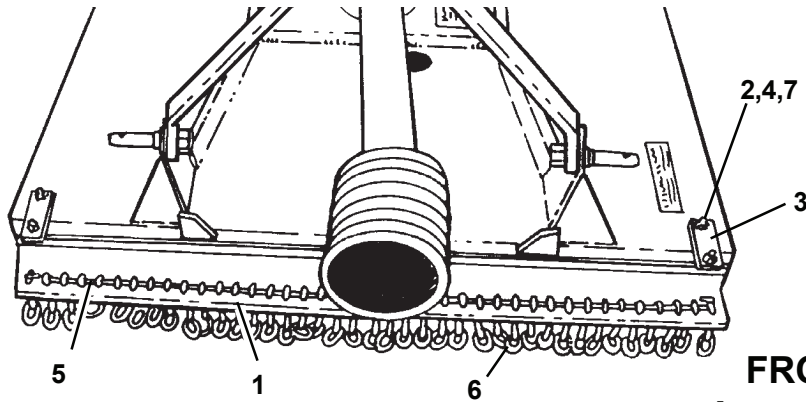

**FRONT CHAIN GUARD
Assembly P/N 0891101000**

ITEM	PART NO.	QTY	DESCRIPTION
1	0891101100	1	Chain Guard Weldment
2	00752680	4	Bolt
3	0901100102	2	Mounting Flat
4	00001800	10	Locknut TLM 1/2 NC PLC
5	0731371001	1	Rod
6	0731361104	51	Chain Links
7	15B800	4	Washers

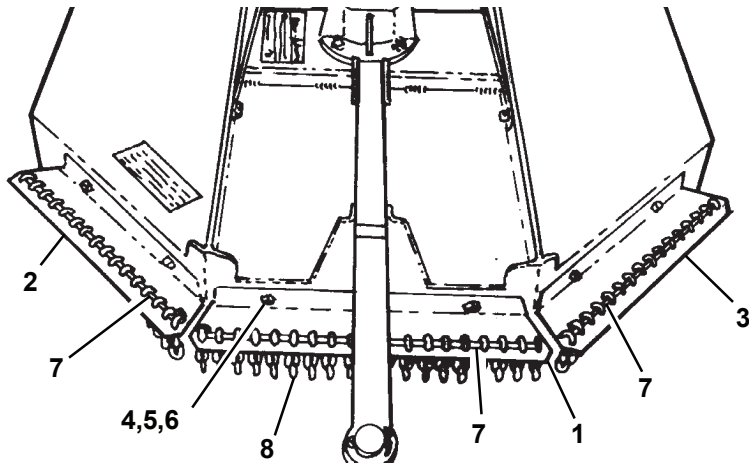

**REAR CHAIN GUARD
Assembly P/N 00761557**

ITEM	PART NO.	QTY	DESCRIPTION
1	00761364	1	Bracket (Center)
2	00761365	1	Bracket (Left)
3	00761366	1	Bracket (Right)
4	00750959	6	Bolt
5	15B800	6	Washer
6	00001800	6	Locknut TLM 1/2 NC PLC
7	00761363	3	Rod
8	0652130101	66	Chain Links

PULL TYPE DRIVELINE P/N 00761057

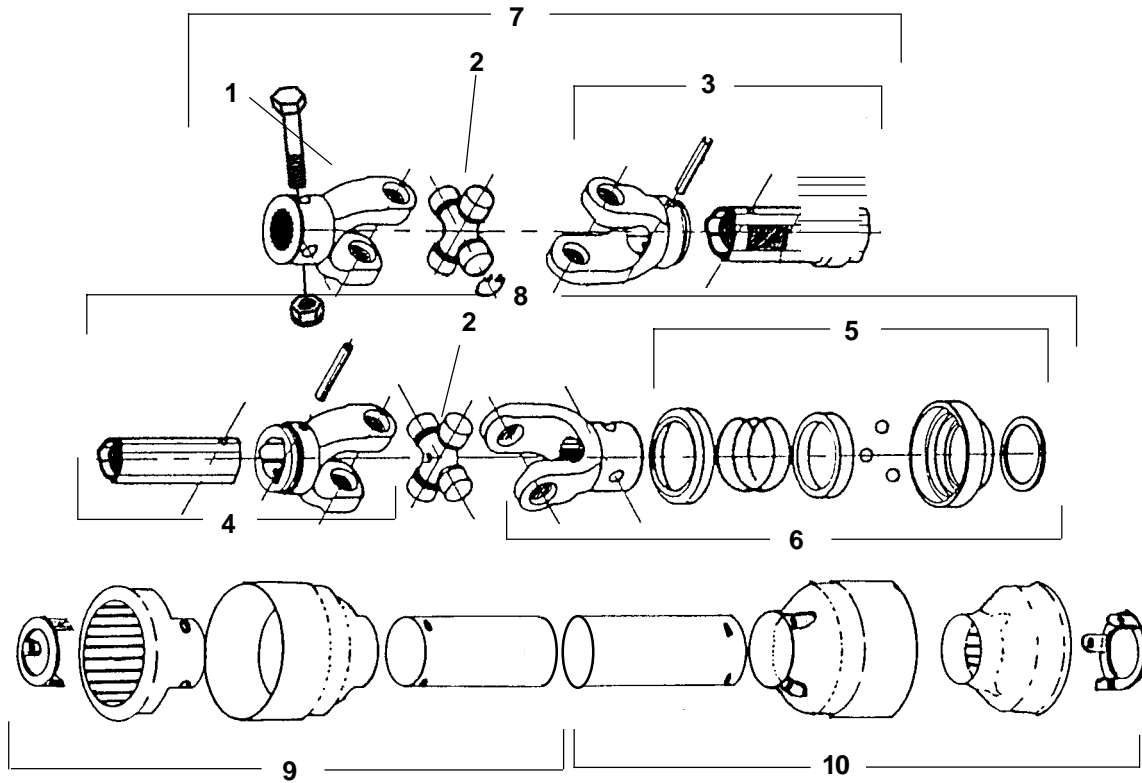

ITEM	PART NO.	QTY	DESCRIPTION
1	00761437	1	Yoke, Shear Pin
2	00761438	2	Cross Journal Set
3	00761439	1	Outer Tube Assembly
4	00761440	1	Inner Tube Assembly
5	00761441	1	Collar Kit
6	00761442	1	Complete Collar Yoke
7	00761443	1	Half Implement Shaft w/Shielding
8	00761444	1	Half Tractor Shaft w/Shielding
9	00761445	1	Half Implement Shield
10	00761446	1	Half Tractor Shield

SLIPCLUTCH (LIFT) P/N 00762242

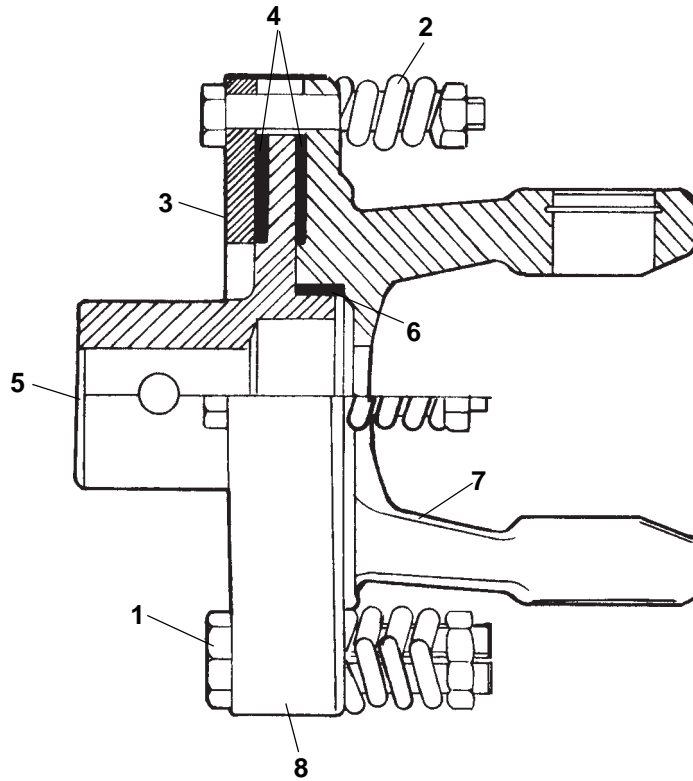

ITEM	PART NO.	QTY	DESCRIPTION
1	00762249	8	Bolt
2	00762250	8	Spring
3	00762247	1	Outer Flange
4	00762248	2	Friction Disc
5	00762243	1	Body - Friction Clutch
6	00762251	1	Spacer
7	00762244	1	Yoke Friction
8	00762252	1	Dirt Shield

LIFT TYPE SLIP CLUTCH DRIVELINE P/N 00759318

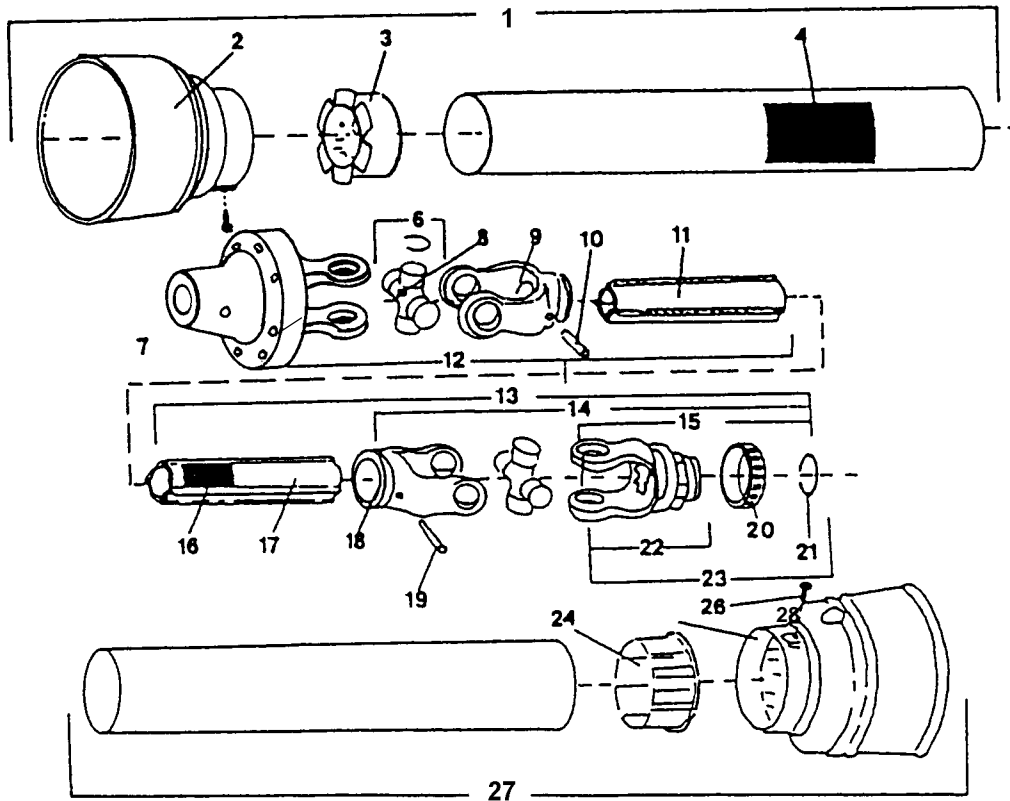

ITEM	PART NO.	QTY	DESCRIPTION
1	00759177	1	Shield Half (Outer)
2	00759526	1	Standard Cone
3	00759527	1	Outer Tube Bearing
4	00756005	1	Driveline Shield Warning Label
6	00756231	2	Cross Assembly
7	00762242	1	Slip Clutch Assembly
8	00759517	2	Grease Fitting
9	00759164	1	Inner Tube Yoke
10	00759165	1	Roll Pin (Inner Tube)
11	00759166	1	Inner Tube
12	00762241	1	Inner Shaft (w/Protector)
13	00759172	1	Outer Shaft (w/Protector)
14	00759521	1	Outer U-Joint
15	00759171	1	Collar Kit
16	00756004	1	Driveline Warning Label
17	00759167	1	Outer Tube
18	00759168	1	Outer Tube Yoke
19	00759169	1	Outer Tube Roll Pin
20	00759516	1	Collar Lock
21	00759515	1	Circlip
22	00754474	1	Push Pin Set
23	00759170	1	Outer Yoke w/Quick Release
24	00759174	1	Inner Tube Bearing
26	00759175	2	Screw
27	00762246	1	Shield Half (Inner)
28	00762245	1	Short Cone

LIFT TYPE SHEAR BOLT DRIVELINE P/N 00759161A

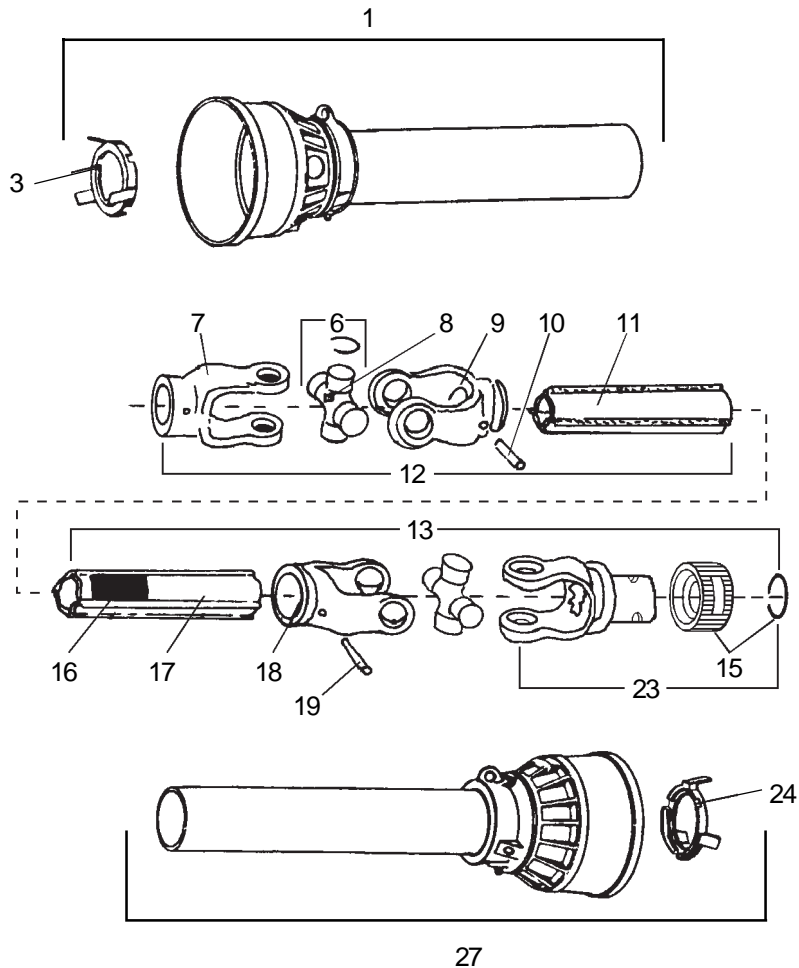

ITEM	PART NO.	QTY	DESCRIPTION
1	00759177A	1	Shield Half (Outer)
3	00762574	1	Outer Tube Bearing
4	00756005	1	Driveline Shield Warning Label
6	00756231	2	Cross Assembly
7	00759162	1	Outer Yoke (Shear Bolt)
8	00759517	2	Grease Fitting
9	00759164	1	Inner Tube Yoke
10	00759165	1	Roll Pin (Inner Tube)
11	00759166	1	Inner Tube
12	00759173A	1	Inner Shaft (w/Protector)
13	00759172A	1	Outer Shaft (w/Protector)
15	00769592	1	Collar Kit
16	00756004	1	Driveline Warning Label
17	00759167	1	Outer Tube
18	00759168	1	Outer Tube Yoke
19	00759169	1	Outer Tube Roll Pin
23	00769591	1	Outer Yoke w/Quick Release
24	00762577	1	Inner Tube Bearing
27	00759176A	1	Shield Half (Inner)

LIFT TYPE SHEAR BOLT DRIVELINE P/N 00759161A

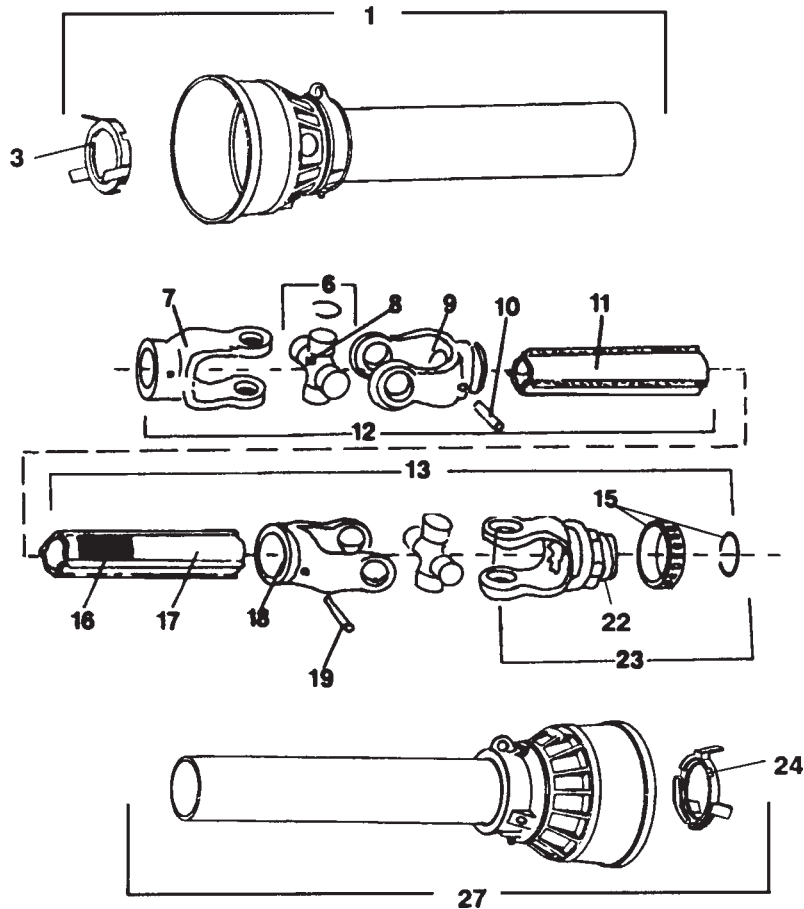

ITEM	PART NO.	QTY	DESCRIPTION
1	00759177A	1	Shield Half (Outer)
3	00762574	1	Outer Tube Bearing
4	00756005	1	Driveline Shield Warning Label
6	00756231	2	Cross Assembly
7	00759162	1	Outer Yoke
8	00759517	2	Grease Fitting
9	00759164	1	Inner Tube Yoke
10	00759165	1	Roll Pin (Inner Tube)
11	00759166	1	Inner Tube
12	00759173A	1	Inner Shaft (w/Protector)
13	00759172A	1	Outer Shaft (w/Protector)
15	00759171	1	Collar Kit
16	00756004	1	Driveline Warning Label
17	00759167	1	Outer Tube
18	00759168	1	Outer Tube Yoke
19	00759169	1	Outer Tube Roll Pin
22	00754474	1	Push Pin Set
23	00759170	1	Outer Yoke w/Quick Release
24	00762577	1	Inner Tube Bearing
27	00759176A	1	Shield Half (Inner)

THREE-POINT HITCH ASSEMBLY

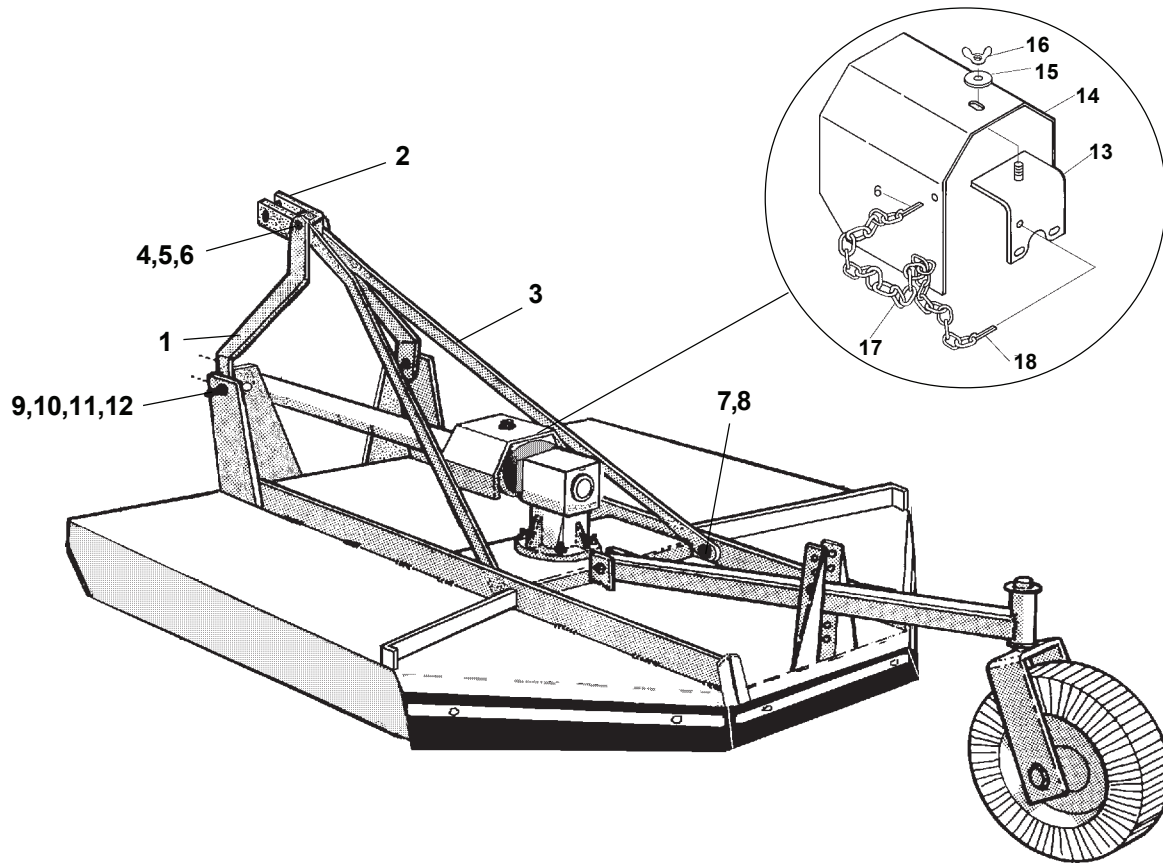

ITEM	PART NO.	QTY	DESCRIPTION
1	00764839	2	"A" Frame Leg
2	00767949	1	Bar Toplink
3	00765331	2	Lift Strap
4	00757953	1	Bushing Spacer
5	02025700	1	Bolt
6	00037200	1	Hex Locknut
7	00001800	3	Locknut TLM 1/2 NC PLC
8	00748823	2	Bolt
9	15B1400	2	Washer, Type "A"
10	00603500	2	Wrist Pin
11	00603600	2	Hex Nut
12	00012200	2	Locknut Washer
13	7540	1	Shield Bracket
14	7541	1	Shield
15	00002700	1	Flatwasher
16	5F8130	1	Wingnut
17	00764259	1	Chain
18	4405	2	Cotter Pin

3-POINT OFFSET ADAPTER P/N 0702310000

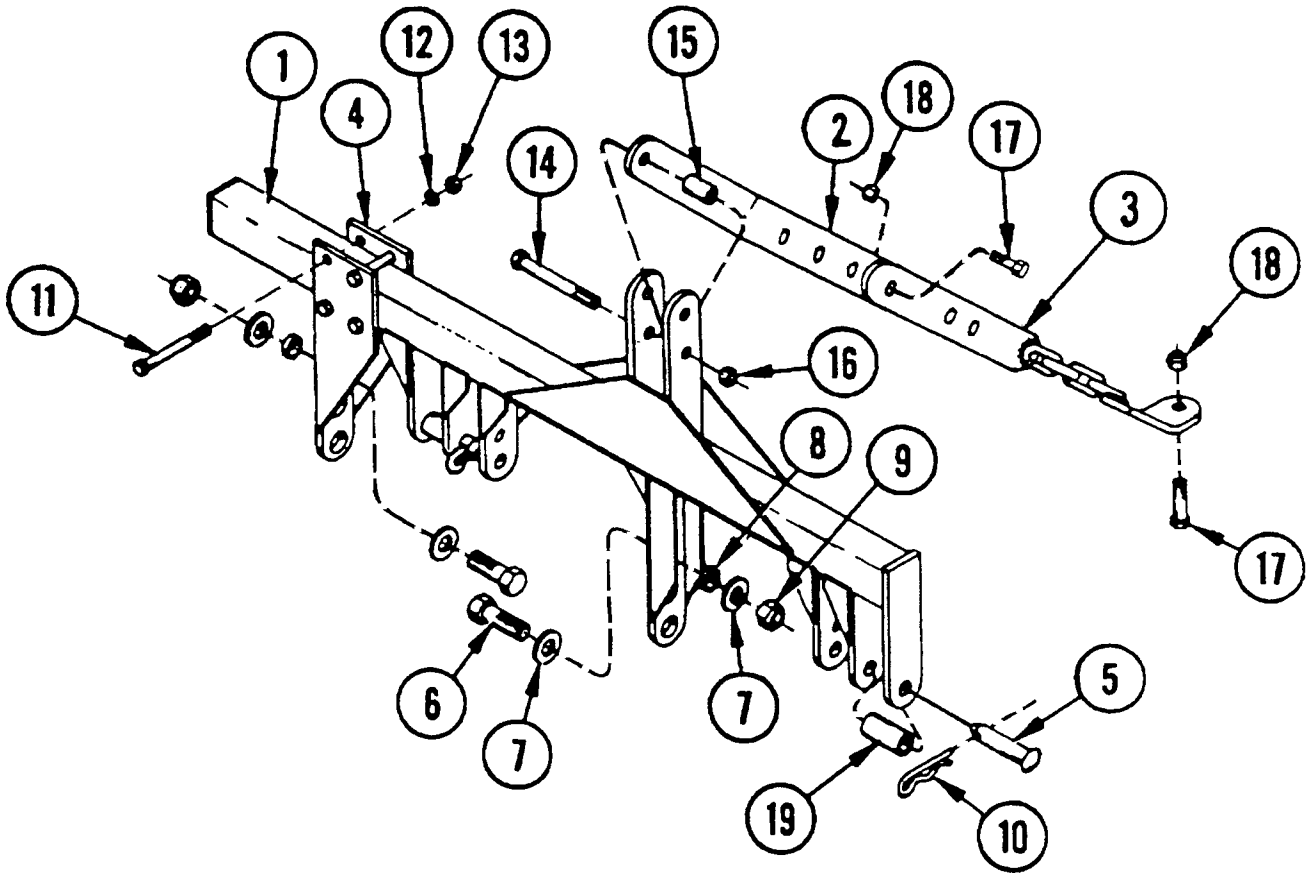

ITEM	PART NO.	QTY	DESCRIPTION
1	0702310100	1	Adapter Mainframe
2	0702310001	1	Brace Bar
3	0702310300	1	Brace Lug and Chain
4	0702310200	1	Adjustable Lift Lug
5	511027	2	Wrist Pin
6	7A14924	2	Bolt
7	15B1400	4	Washer
8	423013	4	Bushing
9	5JRC1490	2	Locknut
10	3W6	2	Retaining Pin
11	02030400	4	Bolt
12	00001300	4	Lockwasher
13	00001200	4	Hex Nut
14	7AH5121636	1	Bolt
15	595062	1	Spacer
16	00748539	1	Locknut
17	7AH5101816	2	Bolt
18	00749136	2	Locknut
19	743013	2	Bushing

TAILWHEEL ASSEMBLY

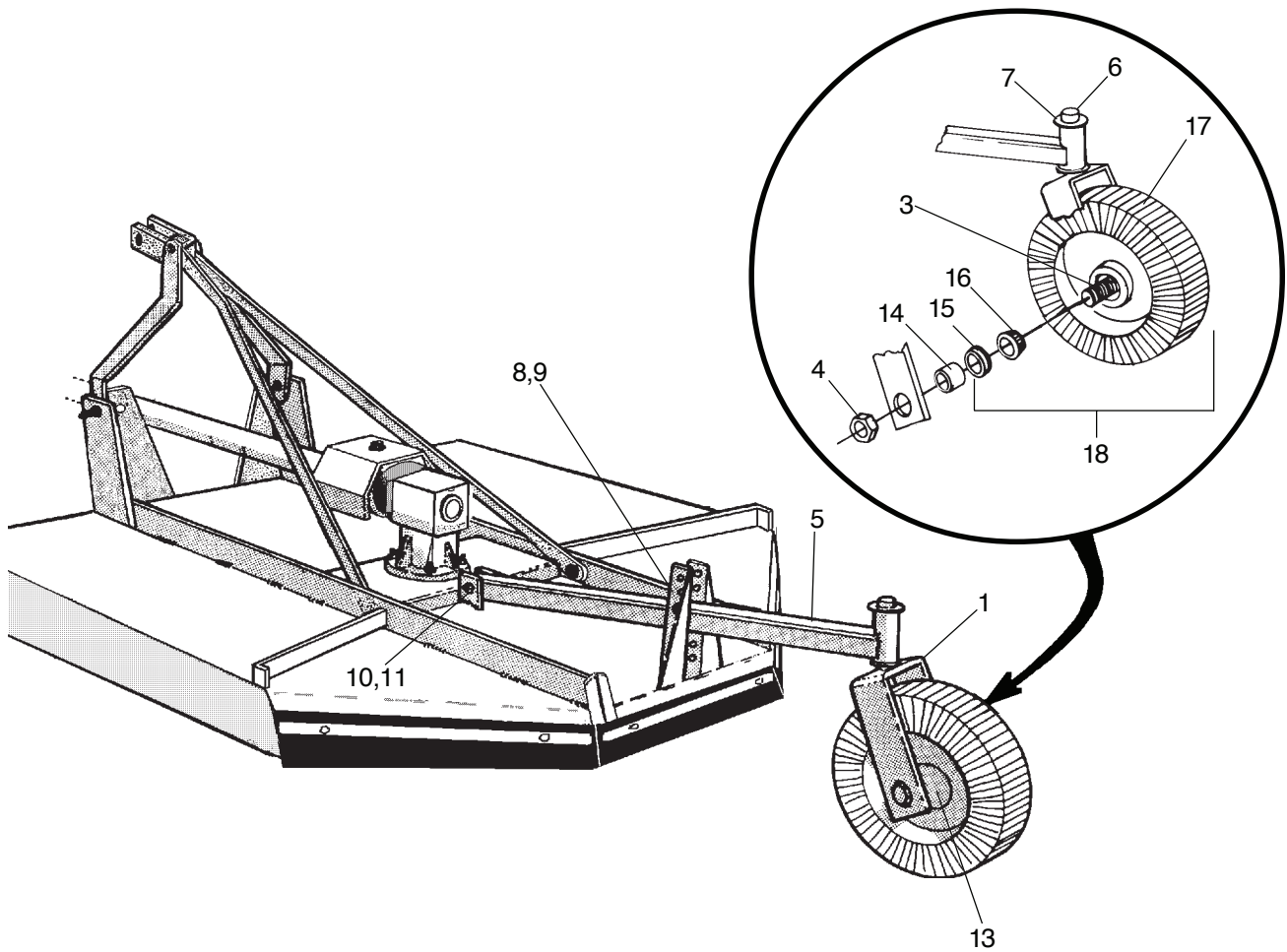

ITEM	PART NO.	QTY	DESCRIPTION
1	0891030100	1	Caster Fork Weldment
3	0891030300	1	Spindle Bolt Weldment
4	5JRC16140	1	Locknut
5	0891020100	1	Tailwheel Beam Weldment
6	00036900	1	Cotter Pin
7	15B2000	1	Type "A" Washer
8	10318000	2	Hex Hd. Capscrew
9	00001800	2	Locknut TLM 1/2 NC PLC
10	00750311	1	Hex Hd. Capscrew
11	00695100	1	Nut, Toplock 5/8 NC PLC
13	02961453	1	Grease Fitting
14	00765337	2	Spacer - Wheel Hub
15	00013600	2	Seal
16	00013701	2	Bearing
17	00756750	1	Tire and Wheel 4 x 8 w/cups
18	000130010	1	Complete Wheel Assembly (includes items 15 thru 17)

HYDRAULIC RELIEF ASSEMBLY P/N 3570

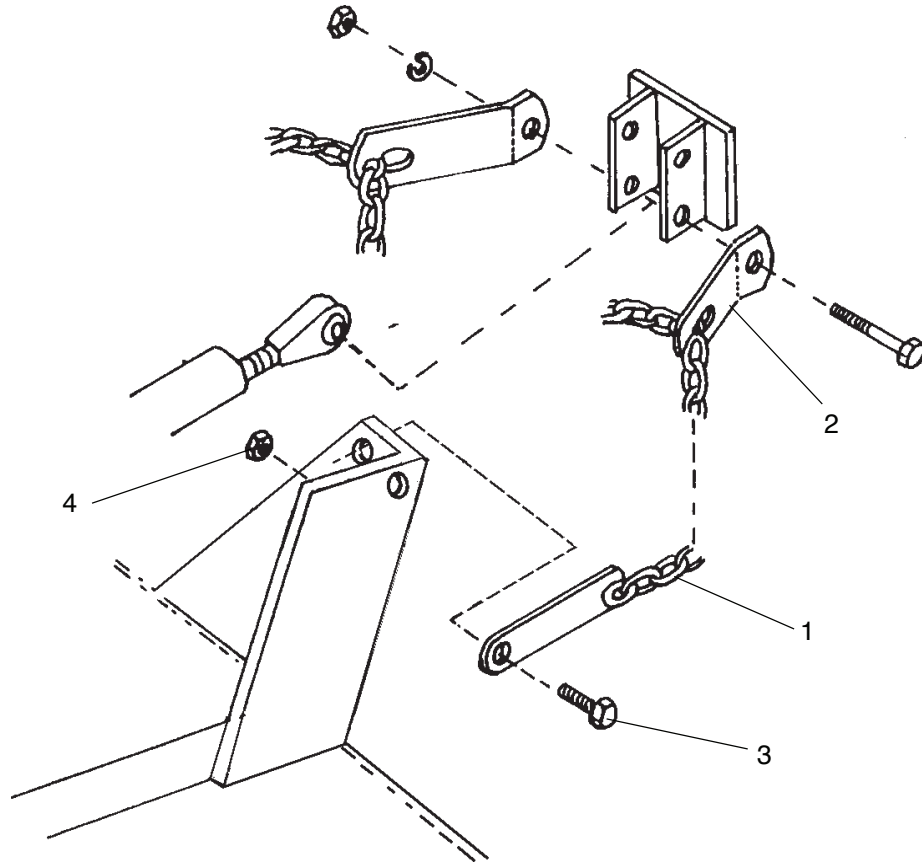

ITEM	PART NO.	QTY	DESCRIPTION
1	8709	2	Chain Assembly
2	8708	2	Bracket
3	02845500	2	Bolt
4	00695100	2	Nut, Toplock 5/8 NC PLC

ALAMO

LIMITED WARRANTY

1. LIMITED WARRANTIES

- 1.01. Alamo warrants for one year from the purchase date to the original non-commercial, governmental, or municipal purchaser ("Purchaser") and warrants for six months to the original commercial or industrial purchaser ("Purchaser") that the goods purchased are free from defects in material or workmanship.
- 1.02. Manufacturer will replace for the Purchaser any part or parts found, upon examination at one of its factories, to be defective under normal use and service due to defects in material or workmanship.
- 1.03. This warranty does not apply to any part of the goods which has been subjected to improper or abnormal use, negligence, alteration, modification, or accident, damaged due to lack of maintenance or use of wrong fuel, oil, or lubricants, or which has served its normal life. This warranty does not apply to any part of any internal combustion engine, or expendable items such as blades, shields, guards, or pneumatic tires except as specifically found in your Operator's Manual.
- 1.04. Except as provided herein, no employee, agent, Dealer, or other person is authorized to give any warranties of any nature on behalf of Manufacturer.

2. REMEDIES AND PROCEDURES.

- 2.01. This warranty is not effective unless the Purchaser returns the Registration and Warranty Form to Manufacturer within 30 days of purchase.
- 2.02. Purchaser claims must be made in writing to the Authorized Dealer ("Dealer") from whom Purchaser purchased the goods or an approved Authorized Dealer ("Dealer") within 30 days after Purchaser learns of the facts on which the claim is based.
- 2.03. Purchaser is responsible for returning the goods in question to the Dealer.
- 2.04. If after examining the goods and/or parts in question, Manufacturer finds them to be defective under normal use and service due to defects in material or workmanship, Manufacturer will:
 - (a) Repair or replace the defective goods or part(s).
 - (b) Reimburse Purchaser for the cost of the part(s) and reasonable labor charges (as determined by Manufacturer) if Purchaser paid for the repair and/or replacement prior to the final determination of applicability of the warranty by Manufacturer.
 - (c) The choice of remedy shall belong to Alamo.
- 2.05. Purchaser is responsible for any labor charges exceeding a reasonable amount as determined by Manufacturer and for returning the goods to the Dealer, whether or not the claim is approved. Purchaser is responsible for the transportation cost for the goods or part(s) from the Dealer to the designated factory.

3. LIMITATION OF LIABILITY.

- 3.01. MANUFACTURER DISCLAIMS ANY EXPRESS (EXCEPT AS SET FORTH HEREIN) AND IMPLIED WARRANTIES WITH RESPECT TO THE GOODS INCLUDING, BUT NOT LIMITED TO, MERCHANTABILITY AND FITNESS FOR A PARTICULAR PURPOSE.
- 3.02. MANUFACTURER MAKES NO WARRANTY AS TO THE DESIGN, CAPABILITY, CAPACITY, OR SUITABILITY FOR USE OF THE GOODS.
- 3.03. EXCEPT AS PROVIDED HEREIN, MANUFACTURER SHALL HAVE NO LIABILITY OR RESPONSIBILITY TO PURCHASER OR ANY OTHER PERSON OR ENTITY WITH RESPECT TO ANY LIABILITY, LOSS, OR DAMAGE CAUSED OR ALLEGED TO BE CAUSED DIRECTLY OR INDIRECTLY BY THE GOODS INCLUDING, BUT NOT LIMITED TO, ANY INDIRECT, SPECIAL, CONSEQUENTIAL, OR INCIDENTAL DAMAGES RESULTING FROM THE USE OR OPERATION OF THE GOODS OR ANY BREACH OF THIS WARRANTY. NOTWITHSTANDING THE ABOVE LIMITATIONS AND WARRANTIES, MANUFACTURER'S LIABILITY HEREUNDER FOR DAMAGES INCURRED BY PURCHASER OR OTHERS SHALL NOT EXCEED THE PRICE OF THE GOODS.
- 3.04. NO ACTION ARISING OUT OF ANY CLAIMED BREACH OF THIS WARRANTY OR TRANSACTIONS UNDER THIS WARRANTY MAY BE BROUGHT MORE THAN TWO (2) YEARS AFTER THE CAUSE OF ACTION HAS OCCURRED.

4. MISCELLANEOUS.

- 4.01. The laws of the State of Texas shall govern the construction of this agreement. Venue for any lawsuits shall be in Guadalupe County, Texas.
- 4.02. Manufacturer may waive compliance with any of the terms of this limited warranty, but no waiver of any terms shall be deemed to be a waiver of any other term.
- 4.03. If any provision of this limited warranty shall violate any applicable law and is held to be unenforceable, then the invalidity of such provision shall not invalidate any other provisions herein.

KEEP FOR YOUR RECORDS

ATTENTION: Purchaser should fill in the blanks below for his reference when buying repair parts and/or for proper machine identification when applying for warranty.

Alamo Implement Model _____ Serial Number _____

Date Purchased _____ Dealer _____

ATTENTION:
READ YOUR OPERATOR'S MANUAL

ALAMO
An Alamo Group Company
Post Office Drawer 549
Seguin, Texas 78156
830-379-1480





In addition to the standard Limited Warranty, Alamo Group provides one year (12 months), (6 months for Commercial/Industrial Users) Limited Warranty on the Driveline components provided that these components have been properly maintained and lubricated that and have not been subjected to abused or mis-use

In addition to the standard Limited Warranty shown on the preceding page, Alamo Group provides **A THREE YEAR LIMITED WARRANTY** on **GEARBOX** components* provided that these components have been properly maintained and lubricated and have not been subjected to abuse or mis-use

*One year for Seals (After on year, (six months for Industrial/Commercial use) seals are considered to be REPLACEMENT PARTS and replacement is the users' responsibility.)

* Users' Gearboxes my be rebuilt by Alamo Group or replaced by new or rebuilt Gearboxes at the option of Alamo Group.

NOTE: "Failure to Maintain" also includes failure to adjust Slip Clutches correctly to provide proper protection for Driveline and Gearbox components.

NOTE: "Failure to Maintain" specifically includes running Gearboxes without proper lubrication and "burning up" the components.

TO THE OWNER/OPERATOR/DEALER

To keep your implement running efficiently and safely, read your manual thoroughly and follow these directions and the Safety Messages in this Manual. The Table of Contents clearly identifies each section where you can easily find the information you need.

The OCCUPATIONAL SAFETY AND HEALTH ACT (1928.51 Subpart C) makes these minimum safety requirements of tractor operators:

REQUIRED OF THE OWNER:

1. Provide a Roll-Over-Protective Structure that meets the requirements of this Standard; and
2. Provide Seatbelts that meet the requirements of this paragraph of this Standard and SAE J4C; and
3. Ensure that each employee uses such Seatbelt while the tractor is moving; and
4. Ensure that each employee tightens the Seatbelt sufficiently to confine the employee to the protected area provided by the ROPS.

REQUIRED OF THE OPERATOR

1. Securely fasten seatbelt if the tractor has a ROPS.
2. Where possible, avoid operating the tractor near ditches, embankments, and holes.
3. Reduce speed when turning, crossing slopes, and on rough, slick, or muddy surfaces.
4. Stay off slopes too steep for safe operation.
5. Watch where you are going - especially at row ends, on roads, and around trees.
6. Do not permit others to ride.
7. Operate the tractor smoothly - no jerky turns, starts, or stops.
8. Hitch only to the drawbar and hitch points recommended by the tractor manufacturer.
9. When the tractor is stopped, set brakes securely and use park lock, if available.



Keep children away from danger all day, every day...



Equip tractors with rollover protection (ROPS) and keep all machinery guards in place...



Please work, drive, play and live each day with care and concern for your safety and that of your family and fellow citizens.

