

Publication 529
January 2008
Part No. 41571.29
Revision: 21.05.09

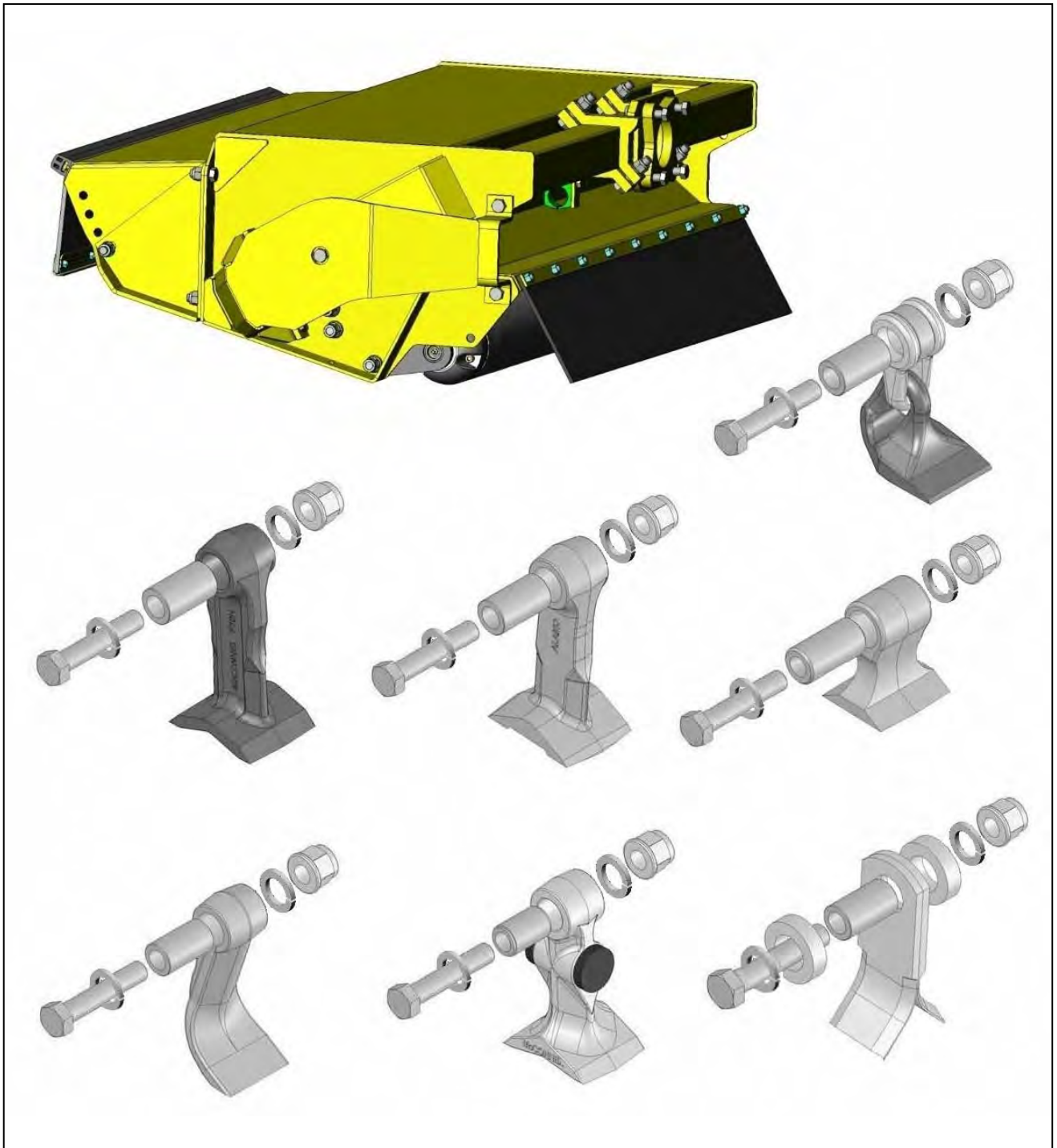

1.2M MULTICUT FLAILHEAD

SLIDING MOUNT & QUAD DRIVE ROTOR
45HP (JIC) / 54HP (BSP) / 65HP (BSP) Builds
Operator & Parts Manual



IMPORTANT

VERIFICATION OF WARRANTY REGISTRATION



DEALER WARRANTY INFORMATION & REGISTRATION VERIFICATION

It is imperative that the selling dealer registers this machine with McConnel Limited within 7 days of delivery to the end user – failure to do so may affect the validity of the machine warranty.

To register machines go to the McConnel Limited web site at www.mcconnel.com, log onto 'Dealer Inside' and select the 'Machine Registration button' which can be found in the Service Section of the site. Confirm to the customer that the machine has been registered in the section below.

Should you experience any problems registering a machine in this manner please contact the McConnel Service Department on 01584 875848.

Registration Verification

Dealer Name:
Dealer Address:
Customer Name:
Date of Warranty Registration:/...../..... Dealer Signature:

NOTE TO CUSTOMER / OWNER

Please ensure that the above section above has been completed and signed by the selling dealer to verify that your machine has been registered with McConnel Limited.

IMPORTANT: During the initial 'bedding in' period of a new machine it is the customer's responsibility to regularly inspect all nuts, bolts and hose connections for tightness and re-tighten if required. New hydraulic connections occasionally weep small amounts of oil as the seals and joints settle in – where this occurs it can be cured by re-tightening the connection – *refer to torque settings chart below*. The tasks stated above should be performed on an hourly basis during the first day of work and at least daily thereafter as part of the machines general maintenance procedure.

TORQUE SETTINGS FOR HYDRAULIC FITTINGS

HYDRAULIC HOSE ENDS		
BSP	Setting	Metric
1/4"	18 Nm	19 mm
3/8"	31 Nm	22 mm
1/2"	49 Nm	27 mm
5/8"	60 Nm	30 mm
3/4"	80 Nm	32 mm
1"	125 Nm	41 mm
1.1/4"	190 Nm	50 mm
1.1/2"	250 Nm	55 mm
2"	420 Nm	70 mm

PORT ADAPTORS WITH BONDED SEALS		
BSP	Setting	Metric
1/4"	34 Nm	19 mm
3/8"	47 Nm	22 mm
1/2"	102 Nm	27 mm
5/8"	122 Nm	30 mm
3/4"	149 Nm	32 mm
1"	203 Nm	41 mm
1.1/4"	305 Nm	50 mm
1.1/2"	305 Nm	55 mm
2"	400 Nm	70 mm

EC DECLARATION OF CONFORMITY

*Conforming to EEC Machinery Directive 98/37/EC**

We,

McCONNEL LIMITED,

Temeside Works, Ludlow, Shropshire SY8 1JL.

Declare under our sole responsibility that:

The product (type) Hydraulic Arm Mounted Flail Head

Product Code BD12, BD16, F110, F112, F115, F012, F016

Serial No. & Date Type

Manufactured by the above company/*

.....
(insert business name and full address if not stated above)*

Complies with the required provisions of the Machinery Directive 98/37/EC, * previously Directive 89/392/EEC as amended by Directives 91/368/EEC, 93/44/EEC and 93/68/EEC.

The machinery directive is supported by;

- BS EN ISO 12100:2003 Safety of Machinery. This standard is made up of two parts; Part 1 Terminology, methodology, Part 2 Technical Specifications.
- BS EN 1050 Safety of machinery - Principles of risk assessment.
- and other national standards associated with its design and construction as listed in the Technical File.

The Machinery Directive is fully implemented into UK law by means of the Supply of Machinery (Safety) Regulations 1992 (SI 1992/3073) as amended by The Supply of Machinery (Safety) (Amendment) Regulations 1994 (SI 1994/2063).

Signed

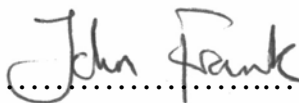

.....
on behalf of **McCONNEL LIMITED**

.....
Responsible Person

Status: Chief Design Engineer

Date: May 2009

CONTENTS

Page No.

Operator Section

General Information	3
Safety Information	5
Pre-Operational Checks	9
Roller Positions	10
Flailhead Arrangement for Mowing	11
Flailhead Arrangement for Hedge Cutting	13
Maintenance	17

Parts Section

Flail Head Assembly	22
Casing Assembly	23
Motor Cover Assembly	24
Drive Modules	25
Quad Drive Assembly	26
Rotor Assemblies (<i>Wrap-around</i>)	27
Rotor Assembly (<i>Omega</i>)	28
Flail Options & Fixings	29
Roller Assembly	30
Front Flap Kit	32
Skid Kit	33
Decal Kits	34

GENERAL INFORMATION

Always read this manual before fitting or operating the machine – whenever doubt exists contact your dealer or the McConnel Service Department for advice and assistance.

Use only McConnel Genuine Service Parts on McConnel Equipment and Machines

DEFINITIONS – *The following definitions apply throughout this manual:*

WARNING

An operating procedure, technique etc., which – can result in personal injury or loss of life if not observed carefully.

CAUTION

An operating procedure, technique etc., which – can result in damage to either machine or equipment if not observed carefully.

NOTE

An operating procedure, technique etc., which – is considered essential to emphasis.

LEFT AND RIGHT HAND

This term is applicable to the machine when attached to the tractor and is viewed from the rear – this also applies to tractor references.

MACHINE & DEALER INFORMATION

Record the Serial Number of your machine on this page and always quote this number when ordering parts. Whenever information concerning the machine is requested remember also to state the make and model of tractor to which the machine is fitted.

Machine Serial Number:

Installation Date:

Machine Model details:

Dealer Name:

Dealer Address:

Dealer Telephone No:

Dealer Email Address:

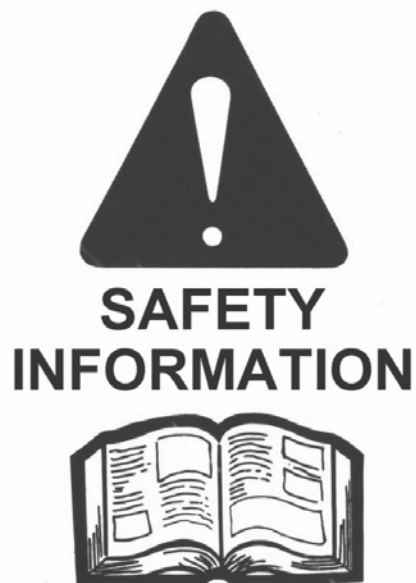

This machine has the potential to be extremely dangerous, in the wrong hands it can kill or maim. It is therefore imperative that both owner, and operator of this machine, read and understand the following section to ensure that they are fully aware of the dangers that do, or may exist, and their responsibilities surrounding the use and operation of the machine. The operator of this machine is responsible not only for their own safety but equally for the safety of others who may come into the close proximity of the machine, as the owner you are responsible for both.

When the machine is not in use the cutting head should be lowered to rest on the ground. In the event of a fault being detected with the machine's operation it should be stopped immediately and not used again until the fault has been corrected by a qualified technician.

POTENTIAL SIGNIFICANT DANGERS ASSOCIATED WITH THE USE OF THIS MACHINE:

- ▲ *Being hit by debris thrown by rotating components.*
- ▲ *Being hit by machine parts ejected through damage during use.*
- ▲ *Being caught on a rotating power take-off (PTO) shaft.*
- ▲ *Being caught in other moving parts i.e.: belts, pulleys and cutting heads.*
- ▲ *Electrocution from Overhead Power Lines (by contact with or 'flashover' from).*
- ▲ *Being hit by cutting heads or machine arms as they move.*
- ▲ *Becoming trapped between tractor and machine when hitching or unhitching.*
- ▲ *Tractor overbalancing when machine arm is extended.*
- ▲ *Injection of high-pressure oil from hydraulic hoses or couplings.*
- ▲ *Machine overbalancing when freestanding (out of use).*
- ▲ *Road traffic accidents due to collision or debris on the road.*

BEFORE USING THIS MACHINE YOU MUST:

- ▲ *Ensure you read all sections of the operator handbook.*
- ▲ *Ensure the operator is, or has been, properly trained to use the machine.*
- ▲ *Ensure the operator has been issued with and reads the operator handbook.*
- ▲ *Ensure the operator understands and follows the instructions in operator handbook.*
- ▲ *Ensure the tractor front, rear and side is fitted with metal mesh or polycarbonate guards of suitable size and strength to protect the operator against thrown debris or parts.*
- ▲ *Ensure tractor guards are fitted correctly, are undamaged and kept properly maintained.*
- ▲ *Ensure that all machine guards are in position, are undamaged, and are kept maintained in accordance with the manufacturer's recommendations.*
- ▲ *Ensure flails and their fixings are of a type recommended by the manufacturer, are securely attached and that none are missing or damaged.*
- ▲ *Ensure hydraulic pipes are carefully and correctly routed to avoid damage by chaffing, stretching or pinching and that they are held in place with the correct fittings.*
- ▲ *Always follow the manufacturer's instructions for attachment and removal of the machine from the tractor.*
- ▲ *Check that the machine fittings and couplings are in good condition.*
- ▲ *Ensure the tractor meets the minimum weight recommendations of the machine's manufacturer and that ballast is used as necessary.*
- ▲ *Always inspect the work area thoroughly before starting to note obstacles and remove wire, bottles, cans and other debris.*
- ▲ *Use clear suitably sized warning signs to alert others to the nature of the machine working within that area. Signs should be placed at both ends of the work site. (It is recommended that signs used are of a size and type specified by the Department of Transport and positioned in accordance with their, and the Local Highways Authority, guidelines).*
- ▲ *Ensure the operator is protected from noise. Ear defenders should be worn and tractor cab doors and windows must be kept closed. Machine controls should be routed through proprietary openings in the cab to enable all windows to be shut fully.*
- ▲ *Always work at a safe speed taking account of the conditions i.e.: terrain, highway proximity and obstacles around and above the machine. Extra special attention should be applied to Overhead Power Lines. Some of our machines are capable of reach in excess of 8 metres (26 feet) this means they have the potential to well exceed, by possibly 3 metres (9' 9"), the lowest legal minimum height of 5.2 metres from the ground for 11,000 and 33,000 volt power lines. It cannot be stressed enough the dangers that surround this capability, it is therefore vital that the operator is fully aware of the maximum height and reach of the machine, and that they are fully conversant with all aspects regarding the safe minimum distances that apply when working with machines in close proximity to Power Lines. (Further information on this subject can be obtained from the Health & Safety Executive or your Local Power Company).*

- ▲ *Always disengage the machine, kill the tractor engine, remove and pocket the key before dismounting for any reason.*
- ▲ *Always clear up all debris left at the work area, it may cause hazard to others.*
- ▲ *Always ensure when you remove your machine from the tractor that it is left in a safe and stable position using the stands and props provided and secured if necessary.*

WHEN NOT TO USE THIS MACHINE:

- ▲ *Never attempt to use this machine if you have not been trained to do so.*
- ▲ *Never use a machine until you have read and understood the operator handbook, are familiar with it, and practiced the controls.*
- ▲ *Never use a machine that is poorly maintained.*
- ▲ *Never use a machine if guards are missing or damaged.*
- ▲ *Never use a machine on which the hydraulic system shows signs of wear or damage.*
- ▲ *Never fit, or use, a machine on a tractor that does not meet the manufacturer's minimum specification level.*
- ▲ *Never use a machine fitted to a tractor that does not have suitable front, rear and side(s) cab guarding made of metal mesh or polycarbonate.*
- ▲ *Never use the machine if the tractor cab guarding is damaged, deteriorating or badly fitted.*
- ▲ *Never turn a machine cutting head to an angle that causes debris to be ejected towards the cab.*
- ▲ *Never start or continue to work a machine if people are nearby or approaching - Stop and wait until they are at a safe distance before continuing. WARNING: Some Cutting Heads may continue to 'freewheel' for up to 40 seconds after being stopped.*
- ▲ *Never attempt to use a machine on materials in excess of its capability.*
- ▲ *Never use a machine to perform a task it has not been designed to do.*
- ▲ *Never operate the tractor or machine controls from any position other than from the driving seat, especially whilst hitching or unhitching the machine.*
- ▲ *Never carry out maintenance of a machine or a tractor whilst the engine is running – the engine should be switched off, the key removed and pocketed.*
- ▲ *Never leave a machine unattended in a raised position – it should be lowered to the ground in a safe position on a level firm site.*
- ▲ *Never leave a tractor with the key in or the engine running.*
- ▲ *Never carry out maintenance on any part or component of a machine that is raised unless that part or component has been properly substantially braced or supported.*
- ▲ *Never attempt to detect a hydraulic leak with your hand – use a piece of cardboard.*
- ▲ *Never allow children near to, or play on, a tractor or machine under any circumstances.*

ADDITIONAL SAFETY ADVICE

Training

Operators need to be competent and fully capable of operating this machine in a safe and efficient way prior to attempting to use it in any public place. We advise therefore that the prospective operator make use of relevant training courses available such as those run by the Agricultural Training Board, Agricultural Colleges, Dealers and McConnel.

Working in Public Places

When working in public places such as roadsides, consideration should be paid to others in the vicinity. Stop the machine immediately when pedestrians, cyclists and horse riders etc. pass. Restart only when they are at a distance that causes no risk to their safety.

Warning Signs

It is advisable that any working area be covered by suitable warning signs and statutory in public places. Signs should be highly visible and well placed in order to give clear advanced warning of the hazard. Contact the Department of Transport or your Local Highways Authority to obtain detailed information on this subject. The latter should be contacted prior to working on the public highway advising them of the time and location of the intended work asking what is required by way of signs and procedure. – ‘*Non-authorised placement of road signs may create offences under the Highways Act*’.

Suggested Warning Signs Required

“Road works ahead” warning sign with a supplementary **“Hedge cutting”** plate. **“For 1 mile”** or appropriate shorter distance may be added to the plate.

“Road narrows” warning sign with supplementary **“Single file traffic”** plate.

White on blue **“Keep right”** (*) arrow sign on rear of machine.

* Note – this applies to UK Market machines where traffic passes to the right of a machine working in the same direction as the traffic flow. The direction, use and colour of the arrow sign will depend on the country of use and the Local Highway Authorities regulations in the locality.

Use of Warning Signs

- ▲ On two-way roads one set of signs is needed facing traffic in each direction.
- ▲ Work should be within 1 mile of the signs.
- ▲ Work only when visibility is good and at times of low risk e.g.: NOT during ‘rush-hour’.
- ▲ Vehicles should have an amber-flashing beacon.
- ▲ Ideally, vehicles should be conspicuously coloured.
- ▲ Debris should be removed from the road and path as soon as practicable, and at regular intervals, wearing high visibility clothing and before removing the hazard warning signs.
- ▲ Collect all road signs promptly when the job is completed.

Although the information given here covers a wide range of safety subjects, it is impossible to predict every eventuality that can occur under differing circumstances whilst operating this machine. No advice given here can replace ‘good common sense’ and ‘total awareness’ at all times, but will go a long way towards the safe use of your McConnel machine.

PRE-OPERATIONAL CHECKS

Check all bolts are tight and that the torque figures are correct for the specific locations indicated below:

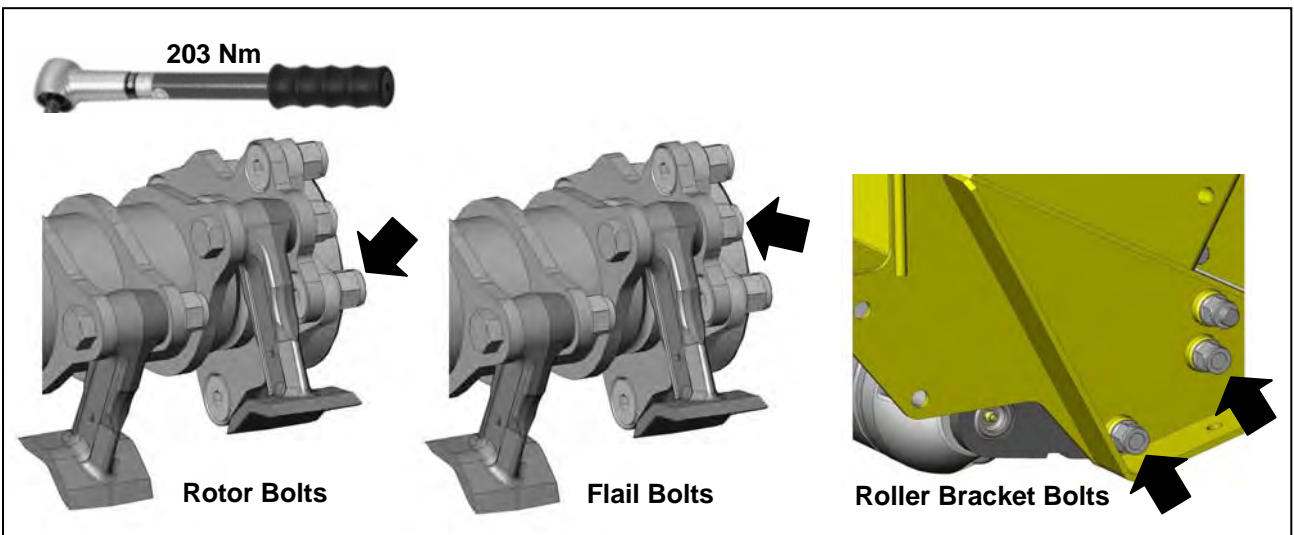
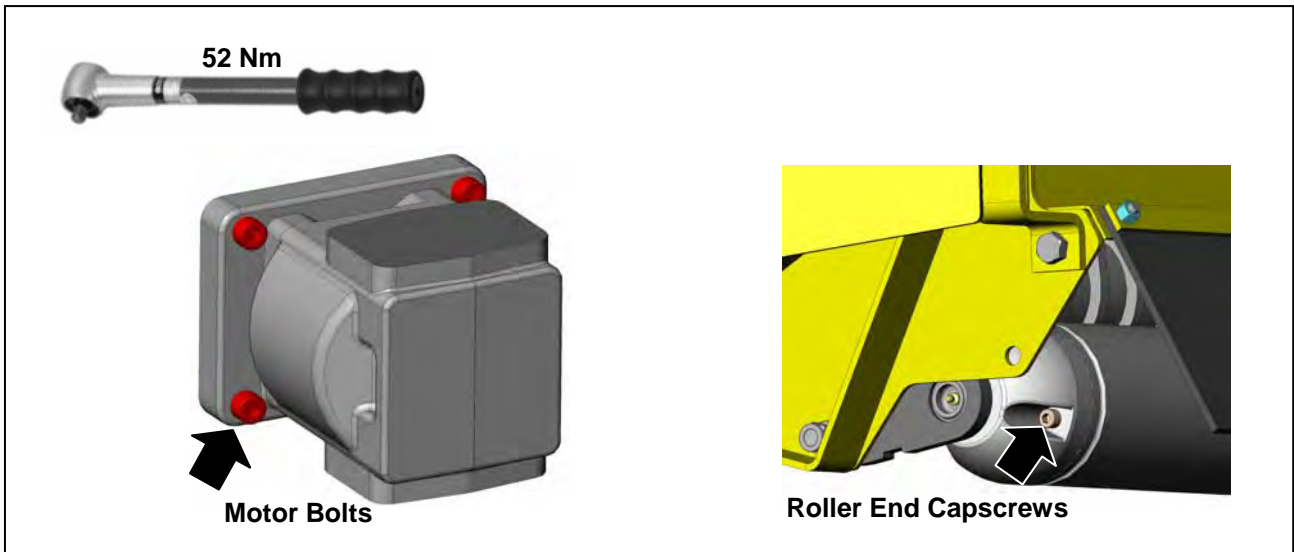

IMPORTANT

On the first day of use with a new flailhead, nuts should be checked for tightness every hour and retightened if required. Thereafter they should be checked on a daily basis prior to use of the machine.

Torque nuts to the settings stated above.

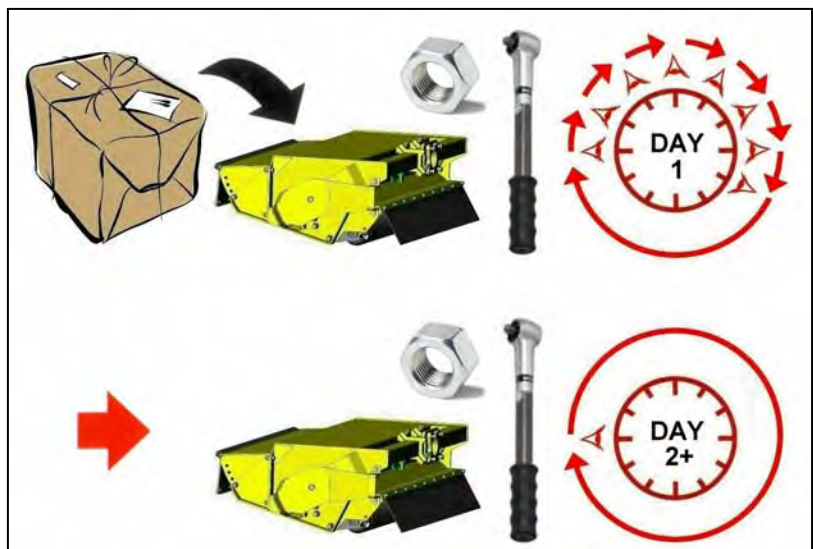

OPERATION

Material Thickness Limitations

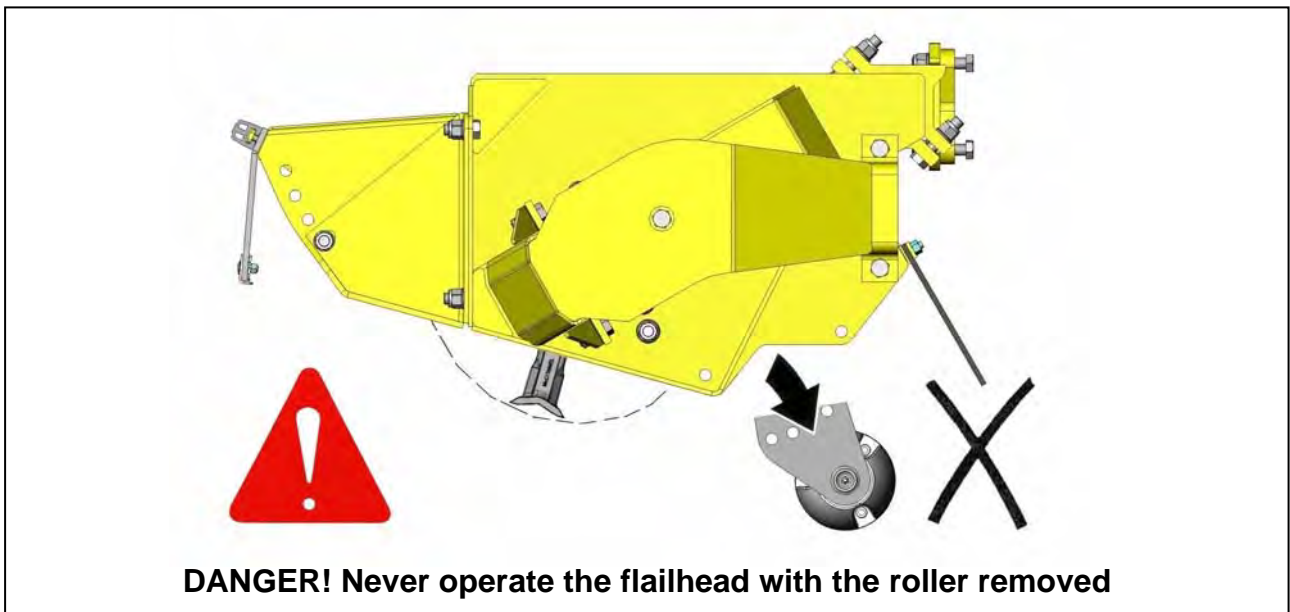

Roller Positions

The opposing pairs of roller brackets have been designed so they can be fitted on either side of the flailhead to provide 10 differing roller heights – 5 height settings in the standard mode and 5 when ‘swapped over’ into the alternate mode. Each mode provides 1 height setting for hedge cutting work where the roller is set above the cut and 4 for grass mowing where the roller is set below the cut – refer to the diagrams on the following page for specific details of the height settings.

WARNING!
Under no circumstances should the flail head be operated with the rear roller removed.

Use roller in position 1 for hedges and 2, 3, 4 or 5 for grass mowing ►

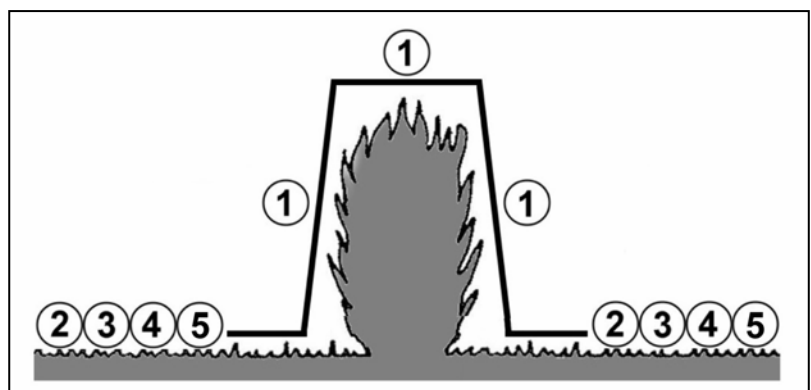

Roller Positions – Standard & Alternate

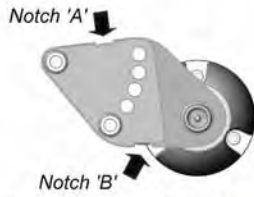

Standard Roller Position



Alternative Roller position

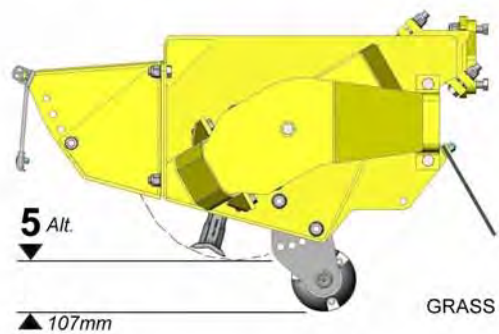
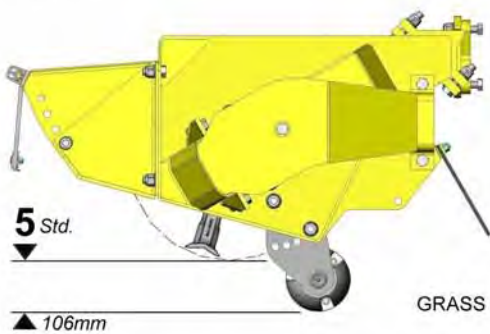
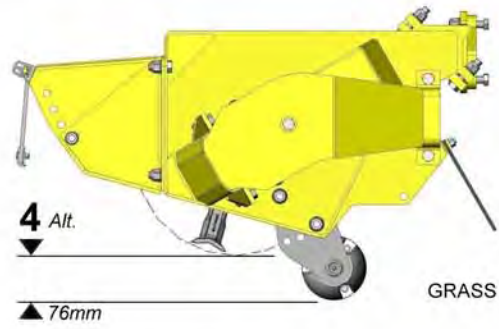
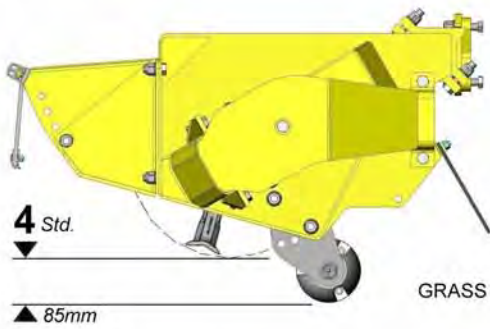
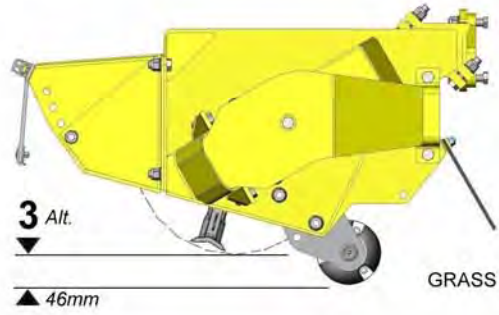
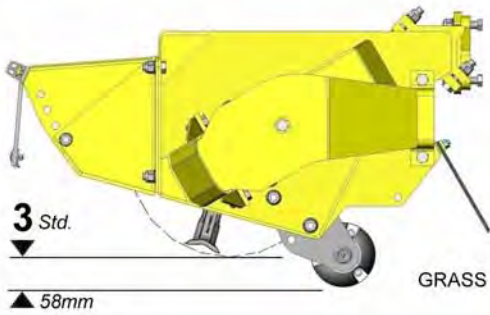
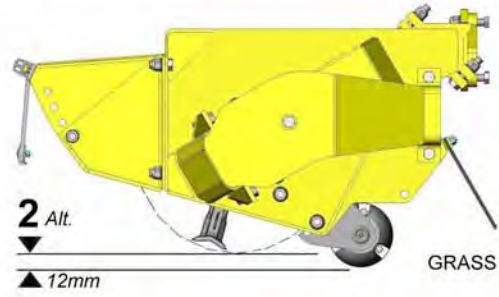
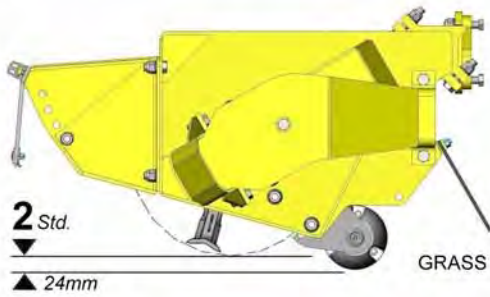
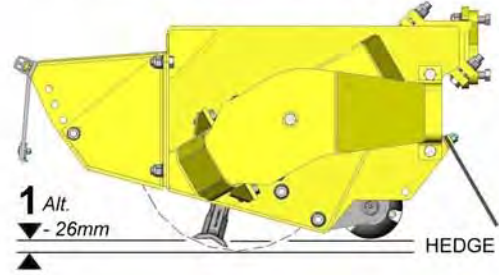
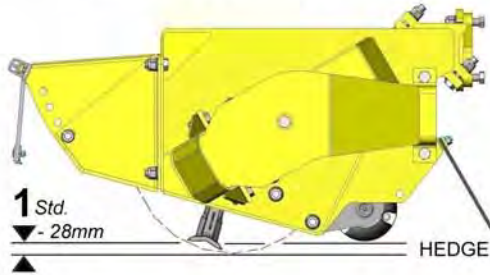

FLAILHEAD ARRANGEMENT – GRASS & VERGE MOWING

Roller Height

The roller position must always be set below the level of the skids, or rotor if skids are not fitted, i.e. in positions 2, 3, 4 or 5, - refer to roller positions on previous page.

Rotor Direction

When mowing the rotor must always cut with an upwards rotation.

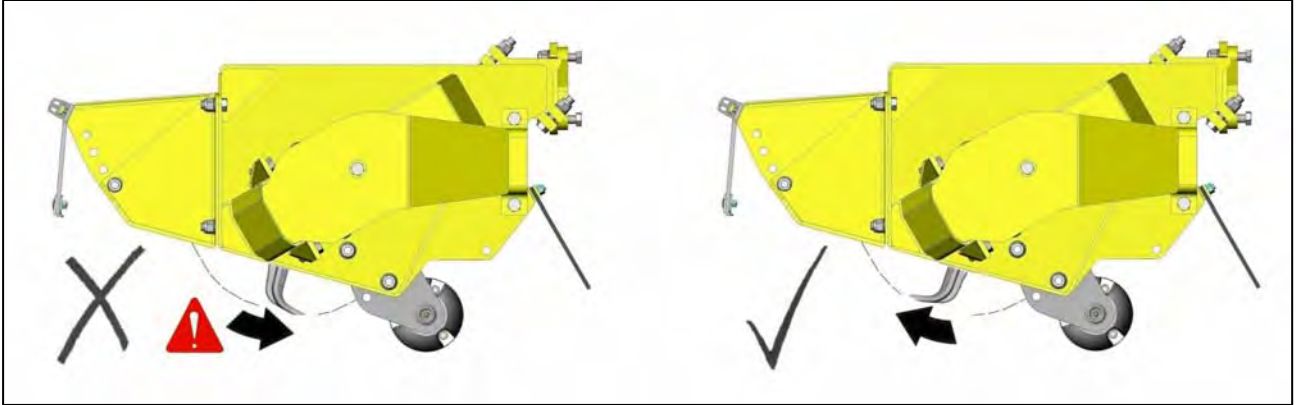

Front Hood

The front hood has 4 adjustment positions for height – the lowest possible position which allows the material to be cut to enter the head should always be used.

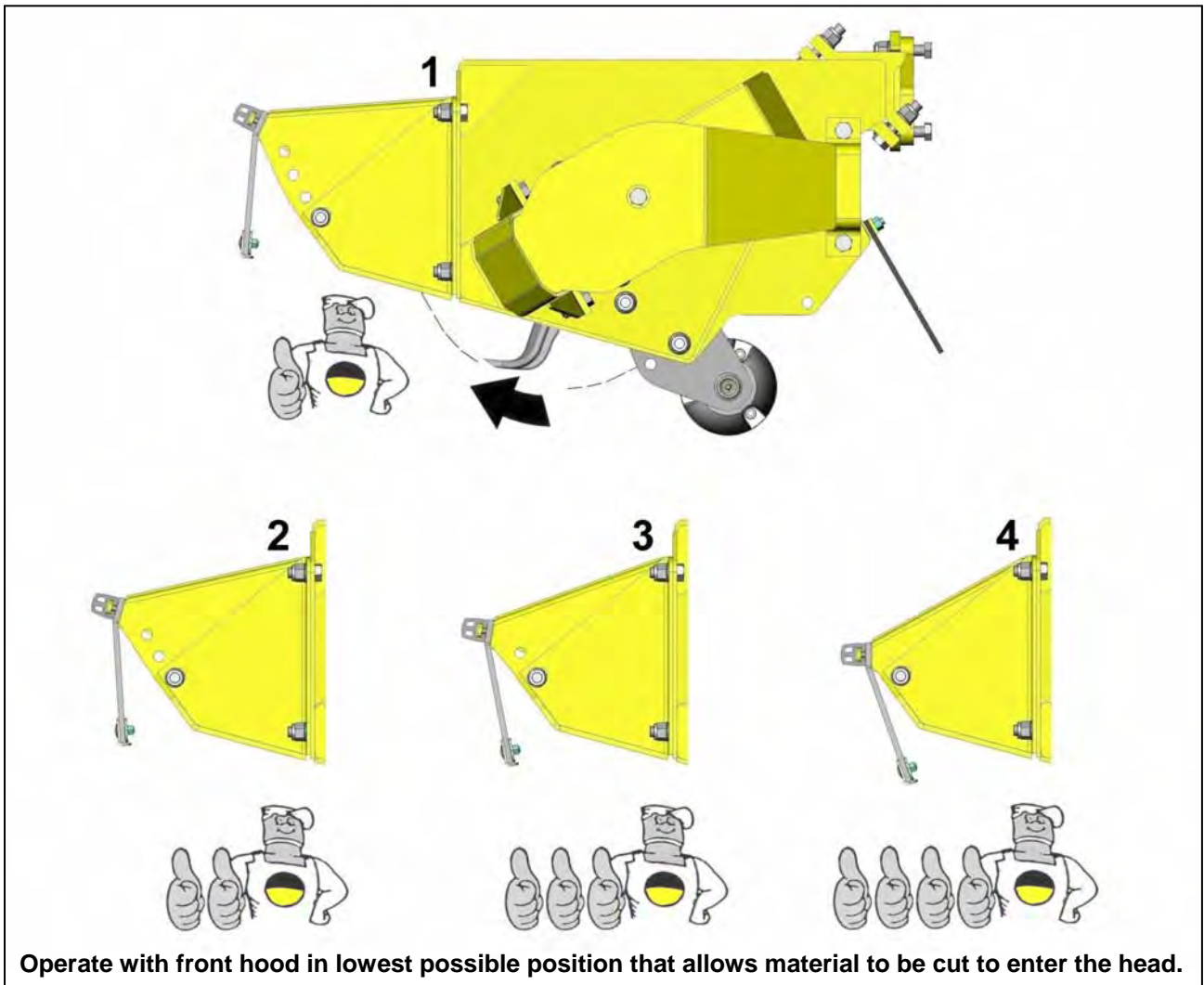

CAUTION:
Before attempting grass mowing ensure the flail head is set up correctly.

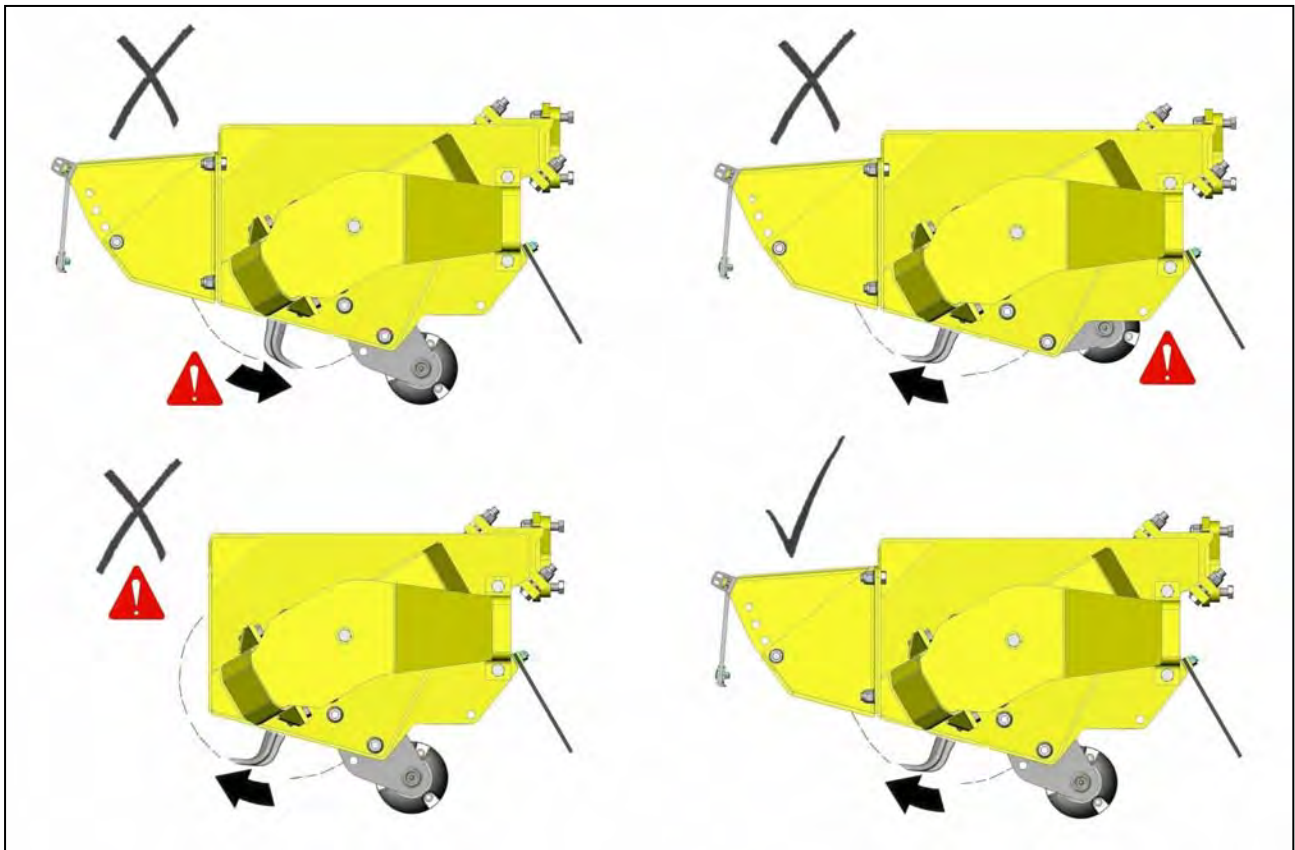

TRACTOR FORWARD SPEED

The material being cut determines tractor forward speed. Forward speed can be as fast as that which allows the flail head sufficient time to cut the vegetation properly. Too fast a speed will be indicated by over frequent operation of the breakaway system, a fall off in tractor engine revs and a poor finish to the work leaving ragged uncut tufts and poorly mulched cuttings.

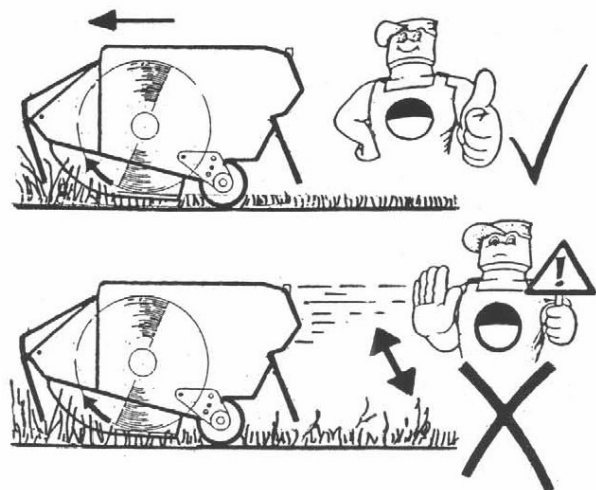

FLAILHEAD ARRANGEMENT - HEDGE CUTTING (Standard Duty)

Roller Height

The roller position must always be set above the level of the rotor in positions 1 - *refer to roller positions page.*

Rotor Direction

For the best finish the rotor should cut with an upwards rotation.

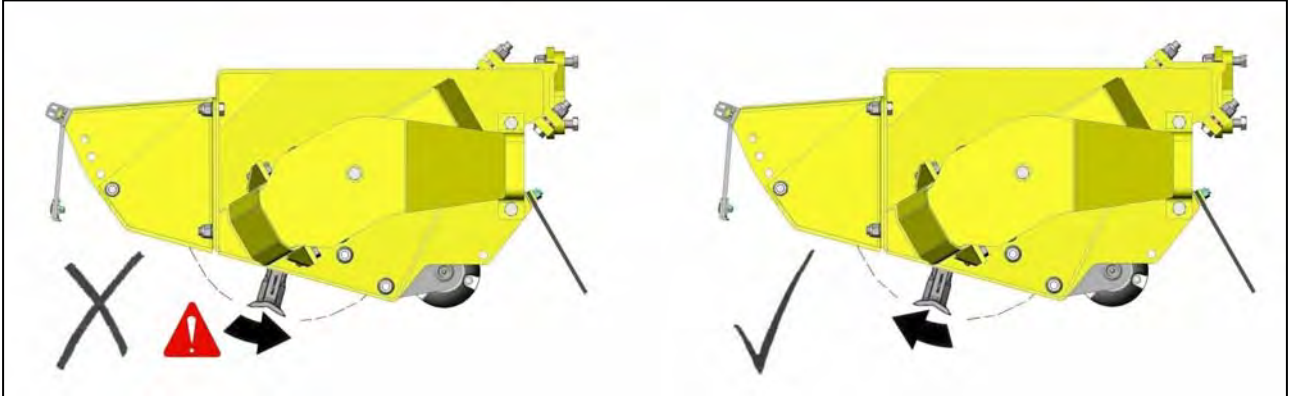

Front Hood

On universal heads the front rubber flaps, and skids if fitted, may be removed to aid the entry of the material to be cut into the flail head.

The front hood has 4 adjustment positions for height – the lowest possible position which allows the material to be cut to enter the head should always be used.

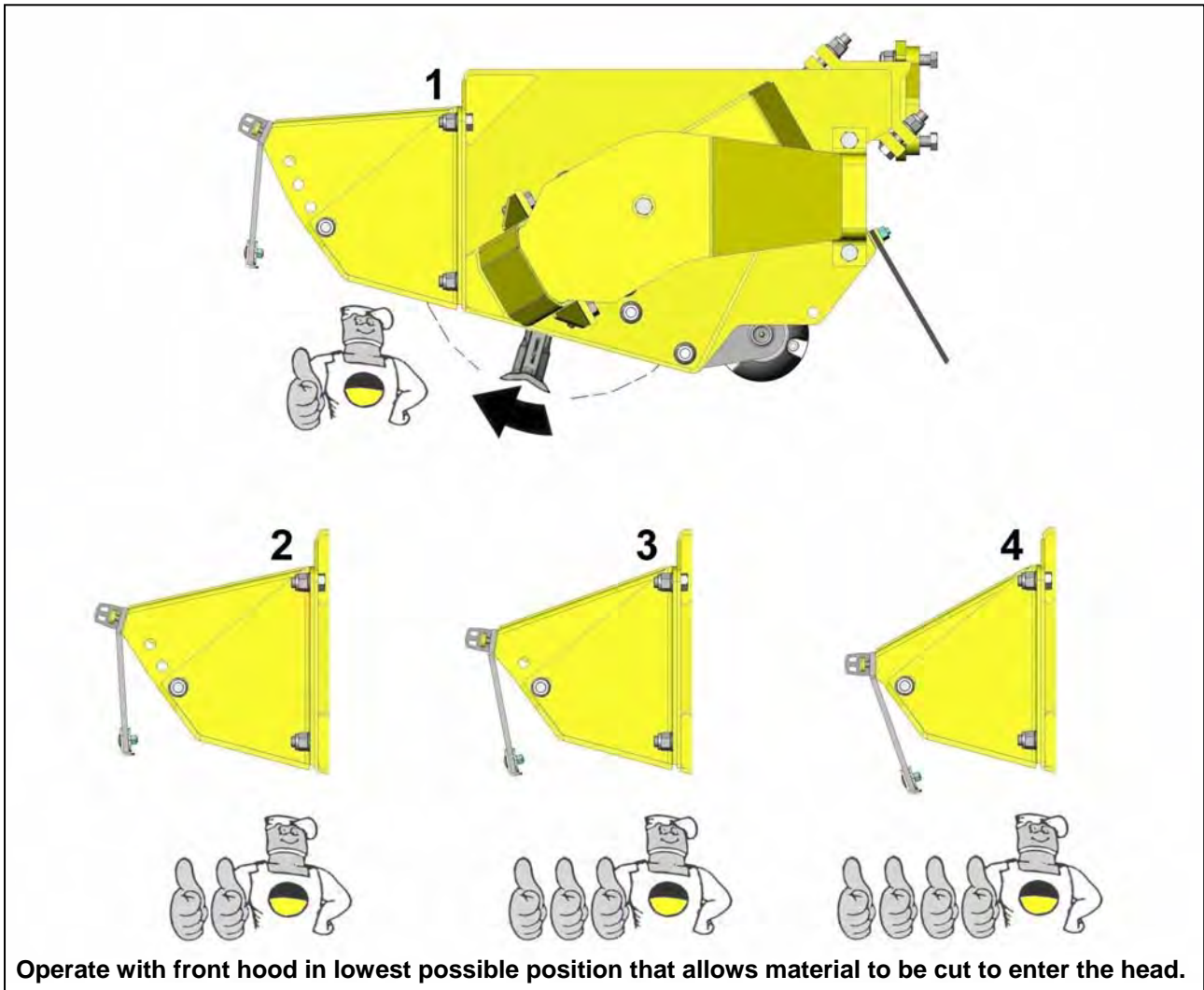



CAUTION!

Before attempting hedge cutting ensure the flail head is set up correctly.

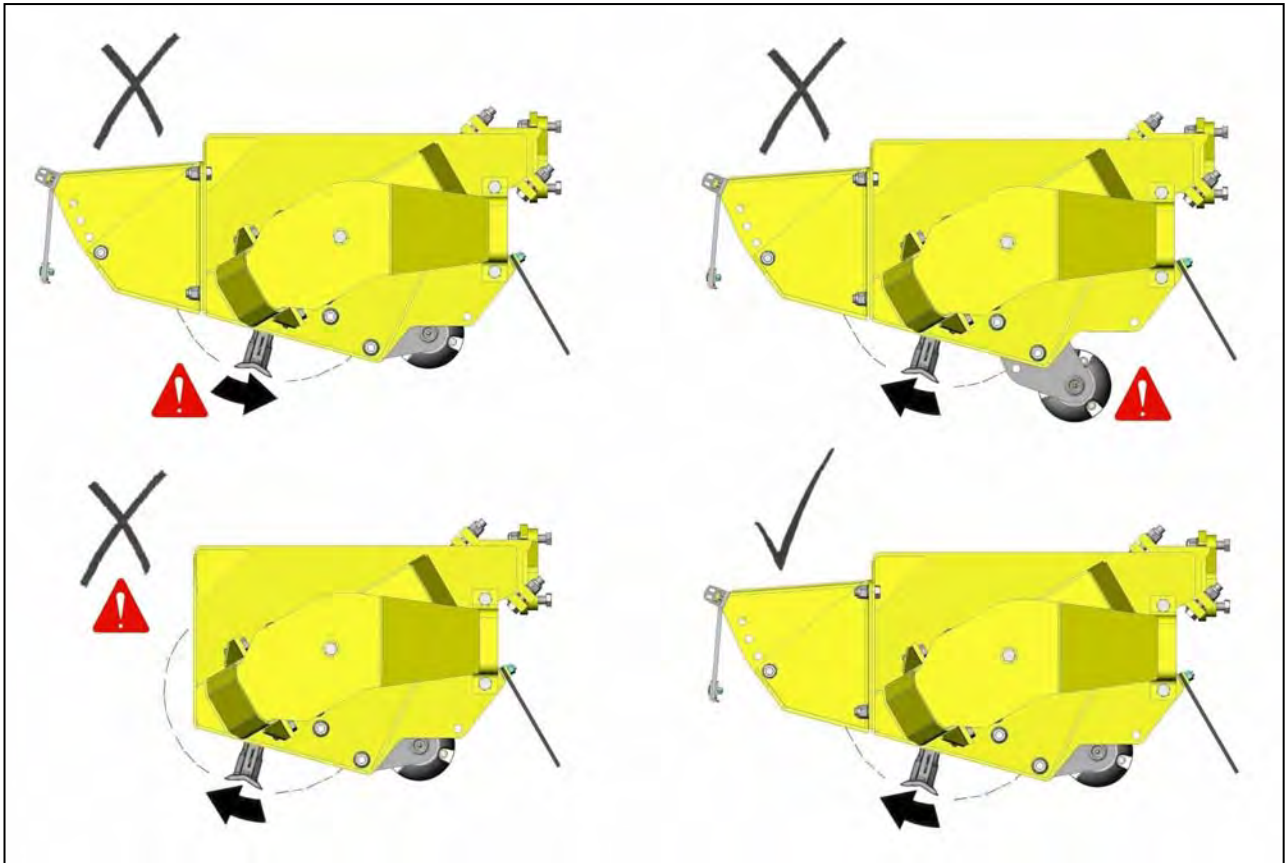

FLAILHEAD ARRANGEMENT - HEDGE CUTTING (Heavy Duty)

Roller Height

The roller position must always be set above the level of the rotor in positions 1 - refer to roller position page.

Rotor Direction

Where the size and density of material to be cut makes it necessary for the front hood and carrier plates to be removed to allow the rotor to cut, the rotor must always cut in a downwards rotation. It must be noted that this will result in a poorer finish to the work and will require more power than upward cutting.

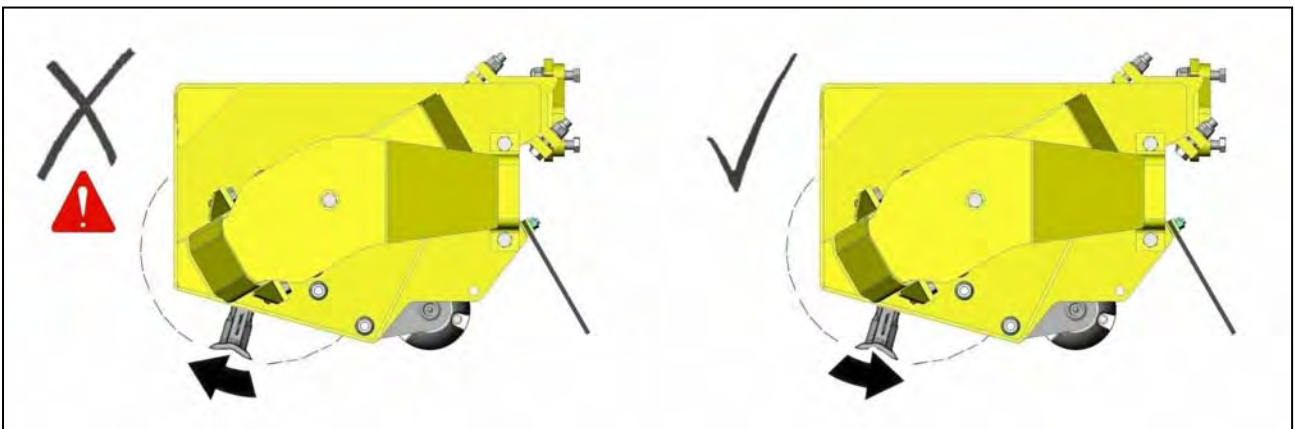

HEDGE CUTTING PROCEDURE



WARNING!

Never cut on the blind side of the hedge

It is impossible to see potential hazards or dangers and the position of the flail head may allow debris to be propelled through the hedge towards the tractor and the operator.

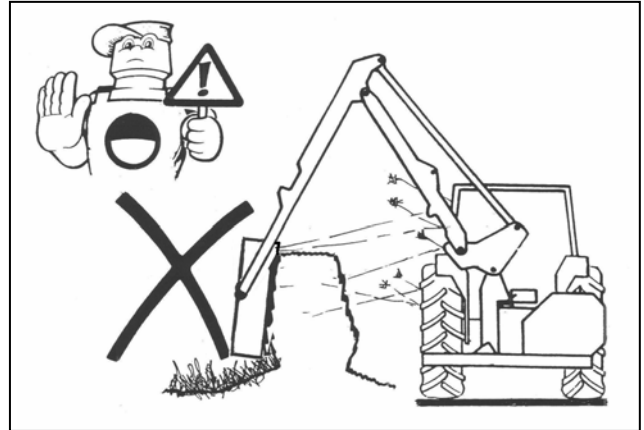

Cut the side and bottom of the field side first. This leaves the maximum thickness of hedge on the road side to prevent the possibility of debris being thrown through the hedge into the path of oncoming vehicles.

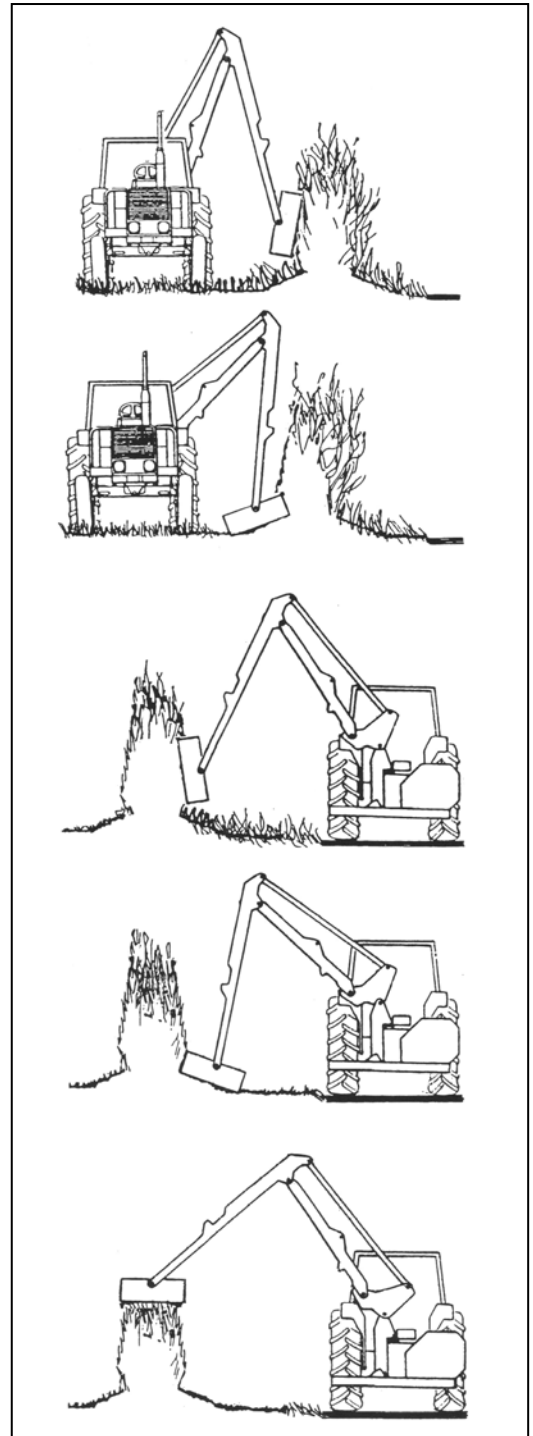

Cut the side and bottom of the road side.

Top cut the hedge to the height required.

FLAIL IDENTIFICATION

The Illustrations below show the various flails and fixings and their specific part numbers.

<p>HEDGE</p>		<p>HEDGE</p>	
	<p>F10 D.E. Cast Flail (Part No. 7314366D)</p>		<p>F10 D.E. Forged Flail (Part No. 41391.02)</p>
<p>HEDGE</p>		<p>HEDGE</p>	
	<p>F10 S.E. Cast Flail (Part No. 7390276)</p>		<p>F16 D.E. Cast Flail (Part No. 21904.02)</p>
<p>HEDGE</p>	<p><i>Omega Rotor use only</i></p>	<p>UNIVERSAL</p>	
	<p>D.E. Omega Flail (Part No. 7190464)</p>		<p>Forged Boot Flail (Part No. 7190462)</p>
<p>GRASS</p>		<p>MULTICUT FIXINGS</p>	<p>OMEGA FIXINGS</p>
	<p>F10 Grass Flail (Part No. 7190315)</p>	<p>Nut (9100024) Bush (7314223) Bolt (7390025) Shackle (7190175)</p>	<p>Nut (0141006) Bush (7190117) Bolt (7390006)</p>
		<p>COMMON FITTINGS Spacer (7190010) Spring Washer (0100206)</p>	

MAINTENANCE

Frequently inspect the rotor assembly for damaged or missing flails – Never operate or attempt to run the rotor with flails missing, imbalance will cause severe vibration and can rapidly damage the rotor shaft bearings. As an emergency measure, if a flail is broken off or missing, removal of an opposing flail on the opposite side of the rotor will retain the balance. Replace the flails at the earliest possible opportunity and always replace in opposite pairs. Never match up a new flail with a sharpened or damaged flail as the latter will be lighter thus causing imbalance of the rotor.

Blunt flails absorb more power and leave an untidy finish to the work. They should be sharpened on a grindstone or with a portable grinder periodically. Always wear protective gear when sharpening flails.

Check on a regular basis, prior to operation that all bolts are tight and that torque figures are correct – refer to pre-operational check page details.

Lubrication

Grease daily the points indicated in the illustration below.

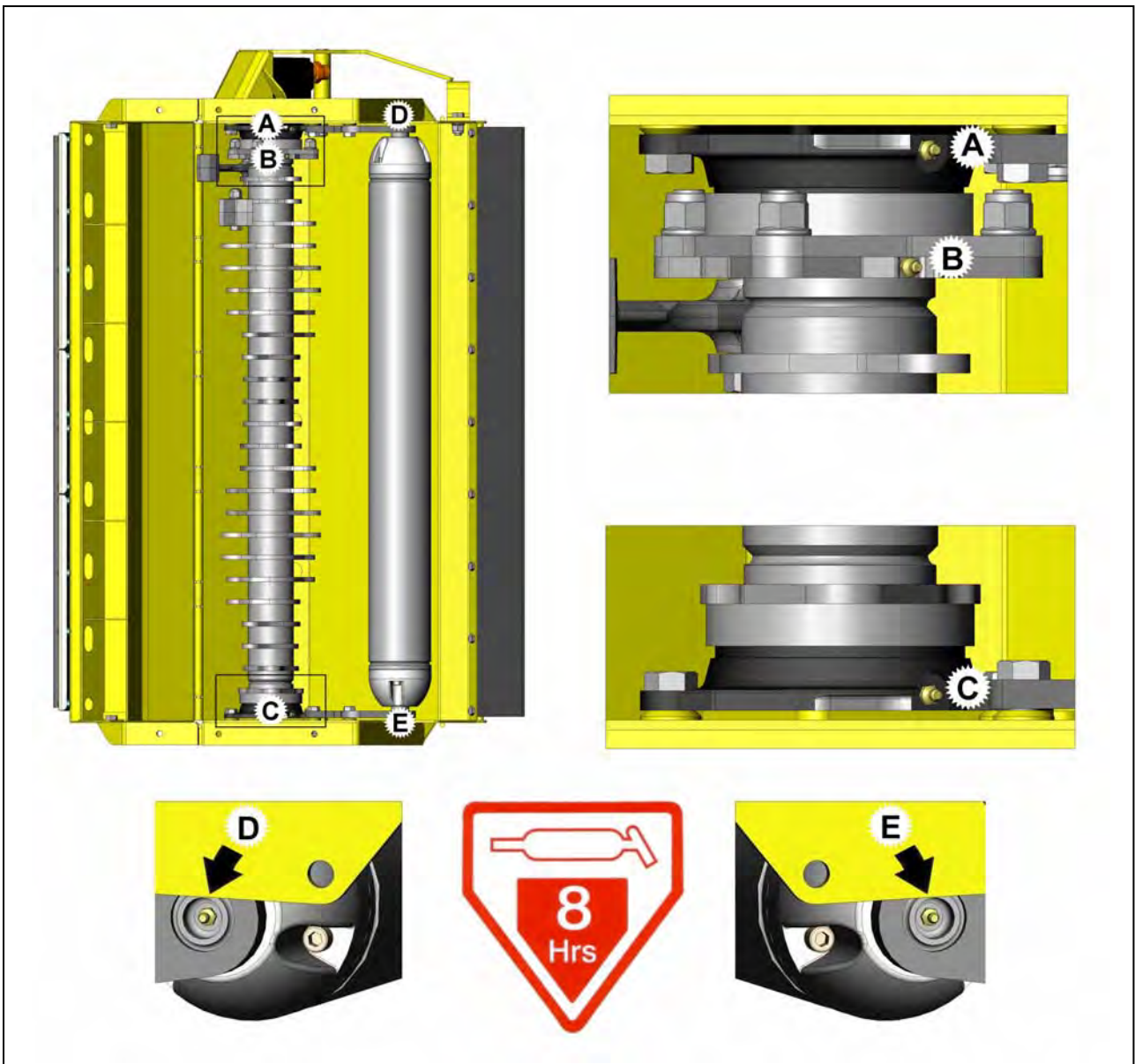

ROTOR SHAFT ALIGNMENT

Rotor shaft hub failure can usually be attributed to rotor misalignment caused by distortion of the flailhead due to the hood or casing receiving a violent blow against an obstruction during work or by dropping the flail head heavily to the ground. These actions should, wherever possible, be avoided.

Where rotor alignment is incorrect or when refitting or replacing rotor components it is imperative that the following procedure for re-assembly is adhered to:

Procedure for re-assembly is as follows:-

1. Press the new bearing fully into the housing and then press the complete assembly onto the rotor shaft until the bearing inner race is firmly against the rotor shoulder.
2. Support the head off the ground in a vertical position. Offer up the complete rotor shaft into the casing, and locate the lower mounting bolts. Tighten the nuts sufficiently to take out all movement and then check the hole alignment at the top end of the casing. If the mounting bolts will not readily fit into place, release the lower bolts and shim between the casing boss and bearing housing until the top holes are aligned.
3. Locate the three top mounting bolts and then tighten the three lower bolts and nuts completely – *torque to a setting of approximately 162Nm (120 ft-lb.)*.
4. Check for clearance between the top bearing housing and casing, and completely shim all gaps before tightening the three mounting bolts to the same torque as above. If there is not clearance between the housing and casing, the bosses will need to be 'ground off' in order to provide clearance for the adding of shims. *Failure to shim all gaps will tend to draw the bearing from the shaft when the bolts are tightened.*

Note

Two sizes of shim are available from McConnel; these are:

Part No. 8121043 for 0.4mm (.015")

Part No. 8121044 for 0.6mm (.025")

Alternatively thin spacing washers .2 may be used. The welded bosses in the casing may be of varying depths - this is a jiggling requirement during manufacture of the head and should not be regarded as a fault.

5. Finally, with the flail head horizontal, turn the rotor over by hand. There should be no binding or tight spots. Replace motor but do not bolt in place, when the rotor is rotated by hand the motor should not move. Movement up and down or side to side indicates a problem.

Warning: Failure to correctly align the rotor shaft may result in the motor shaft breaking.

6. The Coupling should be fitted on to the Motor and the nut tightened to a maximum torque setting of 80Nm (60 ft-lb.) - Do not exceed this value. Prior to the fitting of the motor, the hub and coupling splines should be liberally coated with Morris's K65MS high temperature grease, or equivalent. Experience has indicated that in addition to the pre-pack with Morris's K64MS grease supplied, greasing the rotor bearings, particularly the drive side, twice daily can considerably improve the longevity of the drive hub and coupling.

Rotor Shaft Shim Fitment

Rotor mis-aligned

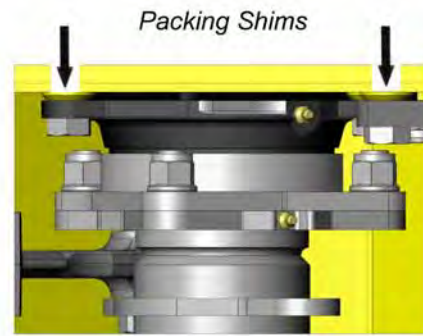
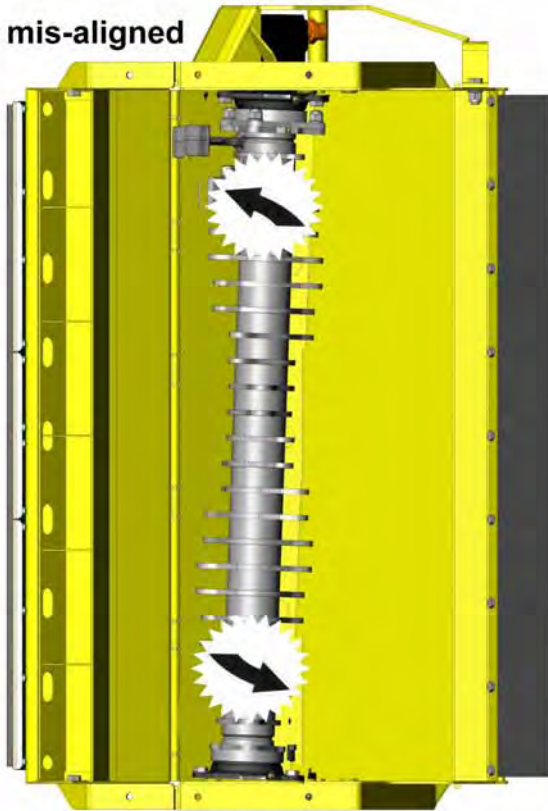

Shim where required to adjust alignment

Rotor aligned

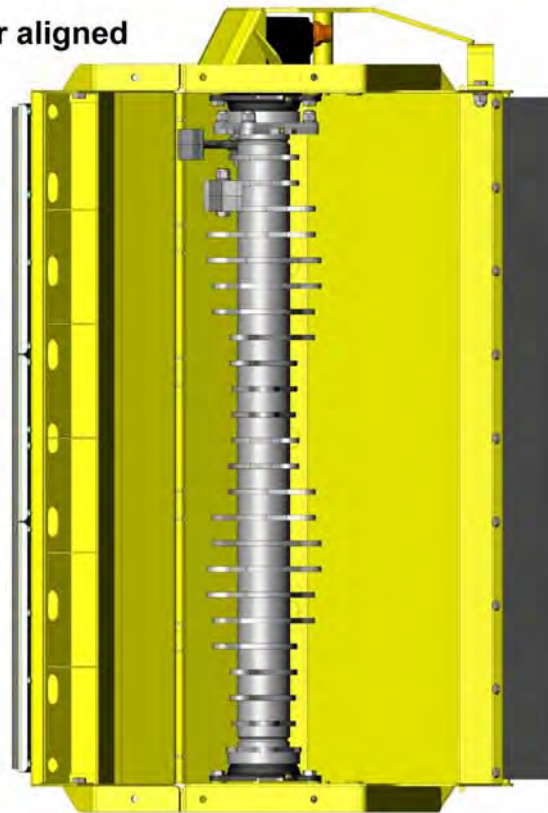



For best performance ...

USE ONLY GENUINE McCONEL SERVICE PARTS

*To be assured of the latest design improvements purchase your
'Genuine Replacements' from the 'Original Equipment Manufacturer'*

McCONEL LIMITED

Through your local Dealer or Stockist

Always quote:

- ***Machine Type***
- ***Serial Number***
- ***Part Number***

Design improvements may alter some of the parts listed in this manual – the latest part will always be supplied when it is interchangeable with an earlier one.

1.2M MULTICUT QUAD DRIVE FLAILHEAD

McCONEL

Module(s): 7354851, 7354866, 7354871 (illustrated), 7354863, 7354883

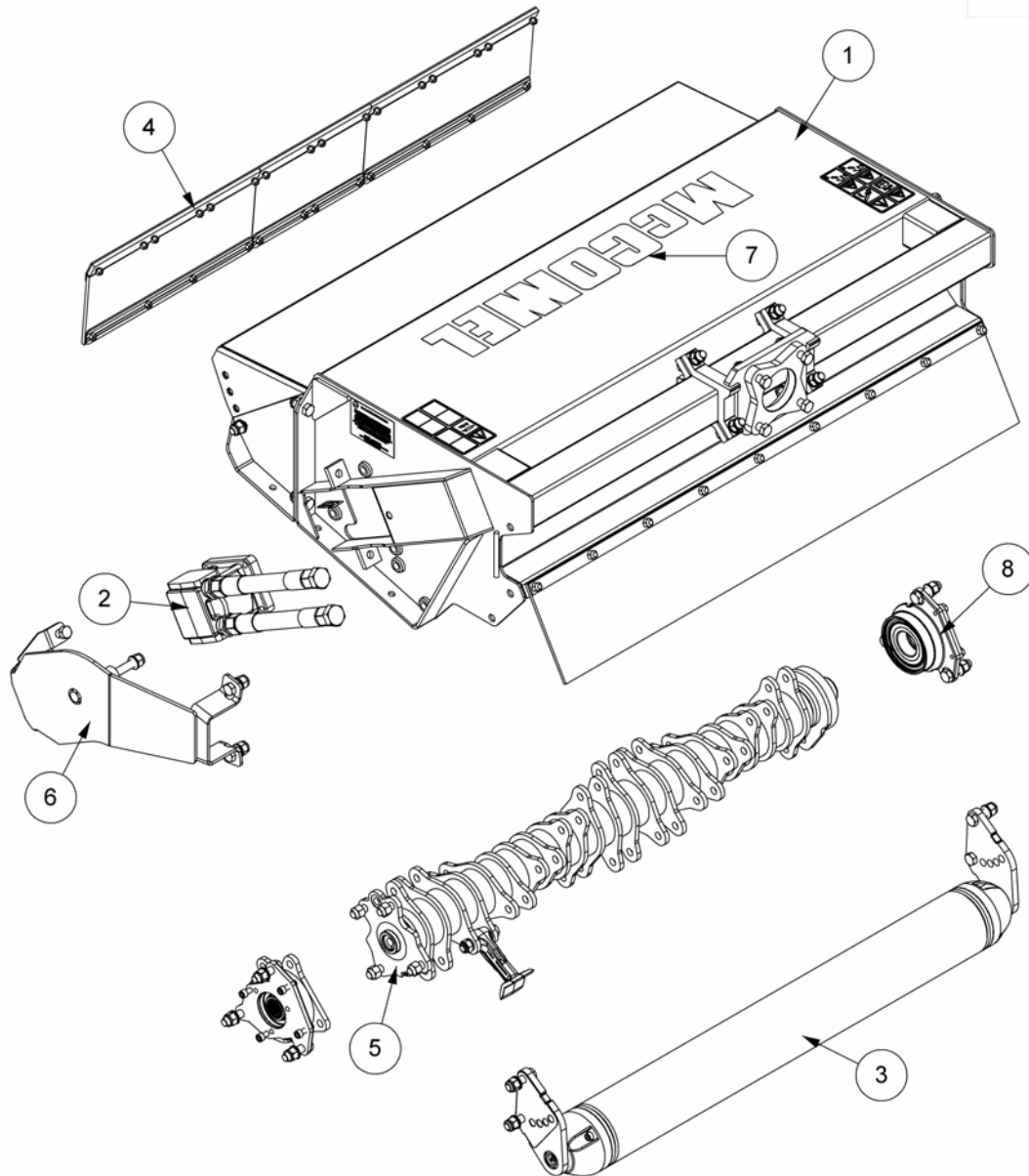

REF.	QTY.	PART No.	DESCRIPTION
		7354851	1.2M MULTICUT 54HP FLAILHEAD
		7354871	1.2M MULTICUT 65HP FLAILHEAD
		7354866	1.2M MULTICUT 45HP FLAILHEAD (JIC Build)
		7354863	1.2M MULTICUT 54HP FLAILHEAD (OMEGA)
		7354883	1.2M MULTICUT 65HP FLAILHEAD (OMEGA)
1	1	22494.05	1.2M DD FLAIL HEAD CASING MODULE
2	1	22495.05	125LPM DRIVE MODULE - 65HP
	1	22495.06	100LPM DRIVE MODULE - 54HP
	1	22495.16	75LPM DRIVE MODULE - 45HP
3	1	21523.08	1.2 DMS ROLLER
4	1	7290375	FRONT FLAP KIT
5	1	22497.01	1.2m QUAD DRIVE ROTOR MODULE
	1	22497.07	1.2m QUAD DRIVE ROTOR MODULE (OMEGA)
6	1	22496.03	LH COVER MODULE
7	1	7350709	DECAL MODULE
8	1	22498.03	MULTICUT QUAD DRIVE MODULE

1.2M FLAILHEAD CASING (DIRECT DRIVE)

McCONNEL

Module(s): 22494.05

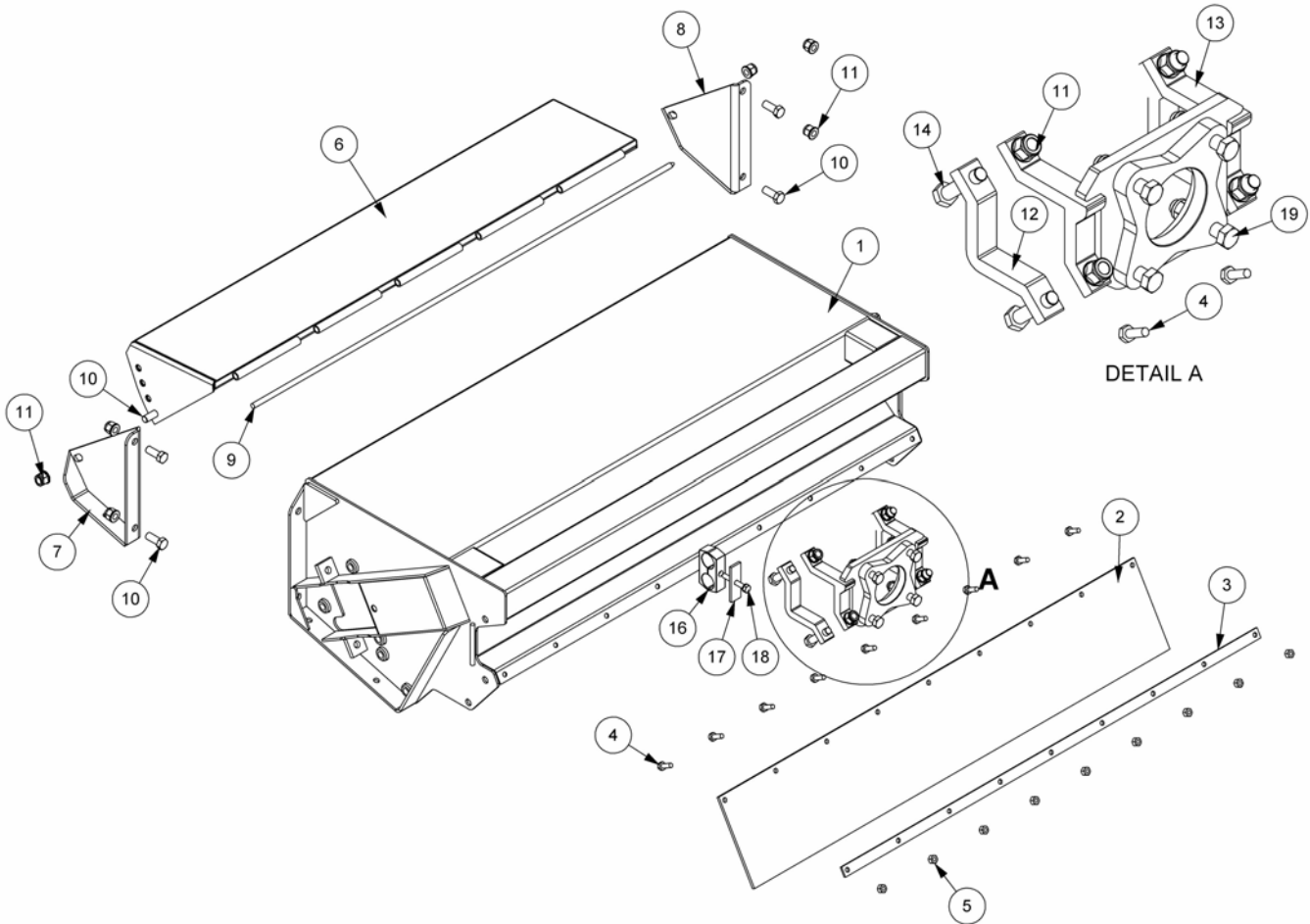

REF.	QTY.	PART No.	DESCRIPTION
		22494.05	1.2M DD FLAILHEAD CASING MODULE
1	1	41685.01	CASING - 1.2m MULTICUT HEAD
2	1	7190314	REAR FLAP
3	1	7190313	CLAMP STRIP
4	9	9313065	SETSCREW
5	9	9143005	SELF-LOCKING NUT
6	1	41695.02	FRONT HOOD - HEAVY DUTY
7	1	7290388	HOOD BRACKET - L/H
8	1	7290387	HOOD BRACKET - R/H
9	1	41700.01	HINGE PIN
10	6	30.073.25	BOLT
11	14	9100024	SELF-LOCKING FLANGE NUT
12	2	7198332	CLAMP
13	1	7198330	CLAMP
14	4	12.714.75	BOLT
15	1	9100205	SPRING WASHER
16	1	7193063	PIPE CLAMP
17	1	06.418.05	CLAMP PLATE
18	1	9213145	BOLT
19	4	9200052	BOLT

MOTOR COVER ASSEMBLY

McCONNEL

Module(s): 22496.03 (Illustrated), 22496.04

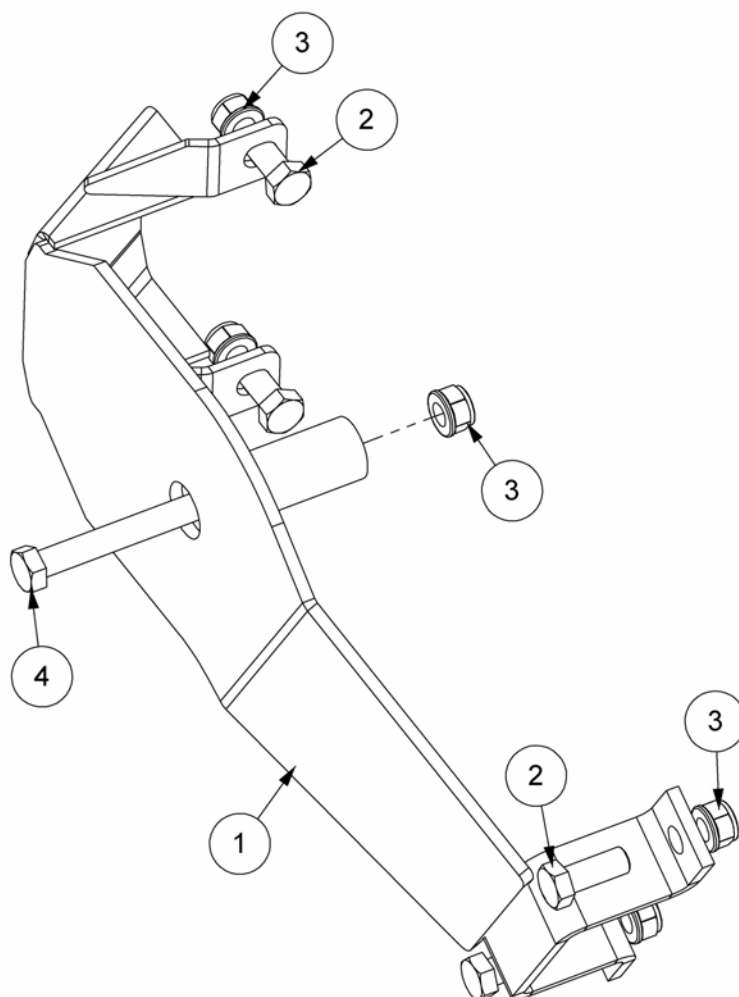

REF.	QTY.	PART No.	DESCRIPTION
		22496.03	MOTOR COVER ASSEMBLY - L/H
		22496.04	MOTOR COVER ASSEMBLY - R/H
1	1	42282.03	MOTOR COVER - L/H
	1	42282.04	MOTOR COVER - R/H
2	4	30.073.25	BOLT
3	5	9100024	SELF-LOCKING FLANGE NUT
4	1	9200034	BOLT

DRIVE MODULES – 45HP/54HP/65HP



Module(s): 22495.05, 22495.06, 22495.16 (JIC)

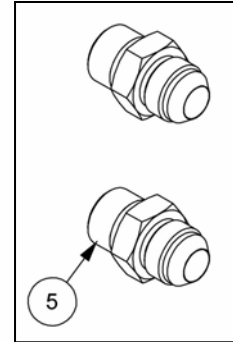
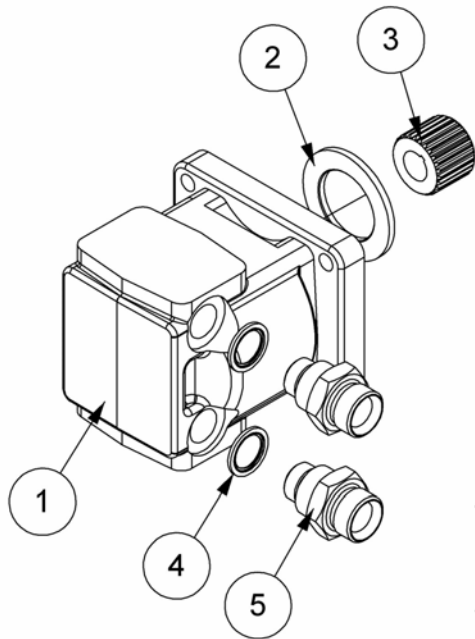

**JIC Adaptors –
Module 22495.16**

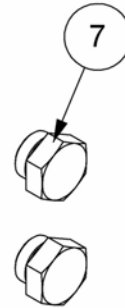
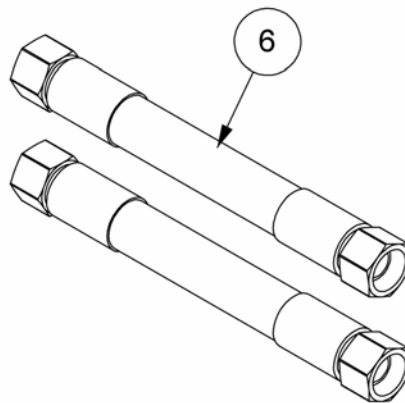

REF.	QTY.	PART No.	DESCRIPTION
		22495.06	100LPM DRIVE MODULE 54HP
		22495.05	125LPM DRIVE MODULE 65HP
1	1	8301302	MOTOR (BACK PORTED) - 54HP
	1	8301304	MOTOR (BACK PORTED) - 65HP
2	1	7190015	LOCATING WASHER
3	1	43390.02	DRIVE COUPLING - 27 TOOTH
4	2	8650106	BONDED SEAL
5	2	8581295	ADAPTOR
6	2	8501254	HOSE - 1" BSP FS/FS x 1900mm
7	2	05.433.03	PLUG

REF.	QTY.	PART No.	DESCRIPTION
		22495.16	75LPM DRIVE MODULE 45HP (JIC)
1	1	8301303	MOTOR (BACK PORTED) - 45HP
2	1	7190015	LOCATING WASHER
3	1	43390.02	DRIVE COUPLING - 27 TOOTH
4	2	8650106	BONDED SEAL
5	2	8581167	ADAPTOR (JIC)
6	2	08.960.32	HOSE - 3/4" BORE 1.1/16" FS/FS x 2100mm

QUAD DRIVE ASSEMBLY

McCONEL

Module(s): 22498.03 (Rev.B)

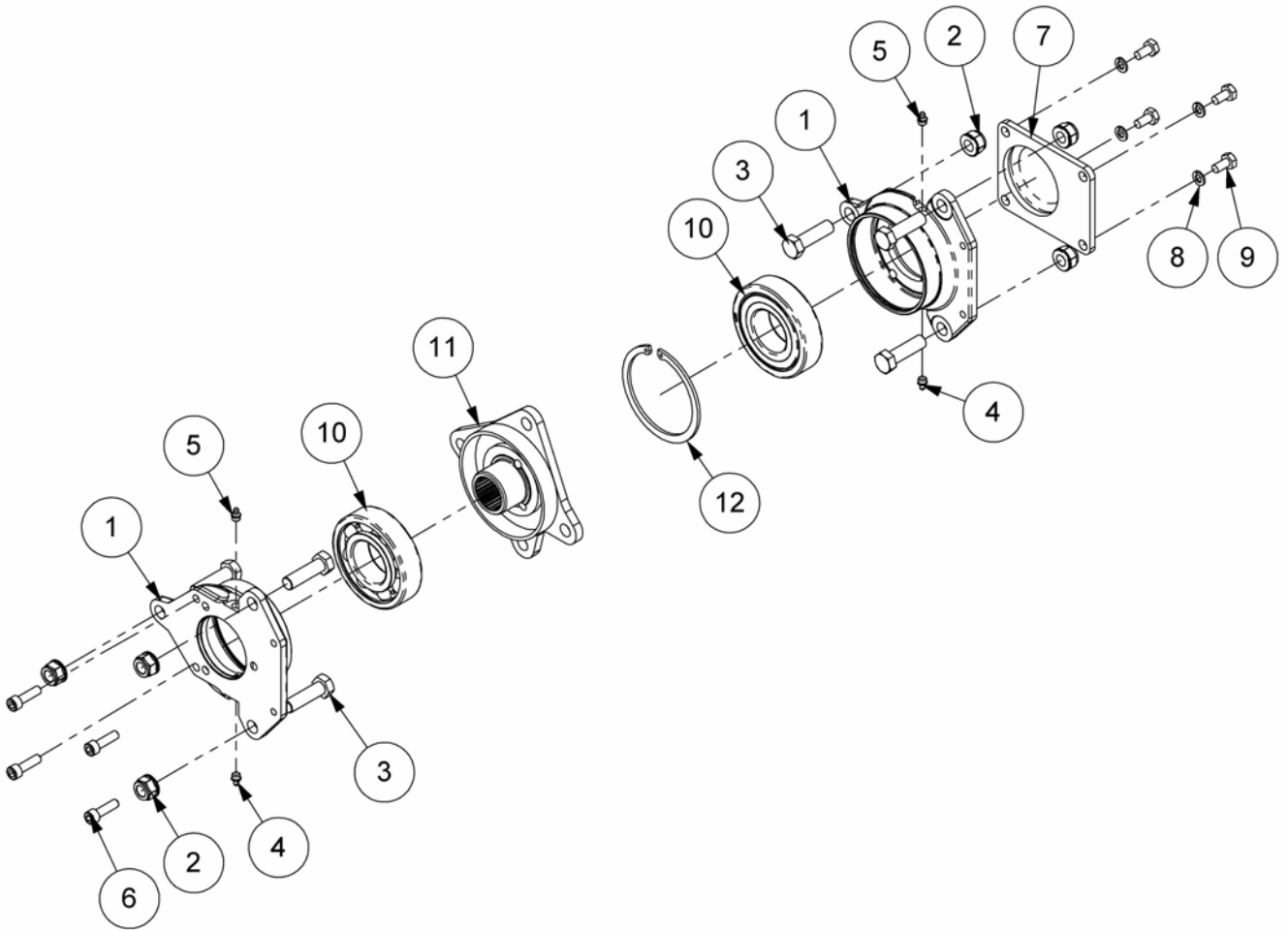

REF.	QTY.	PART No.	DESCRIPTION
		22498.03	MULTICUT QUAD DRIVE ASSEMBLY
1	2	7190261	BEARING HOUSING
2	6	9100024	SELF-LOCKING FLANGE NUT
3	6	9200023	BOLT
4	2	0901121	GREASE NIPPLE - STRAIGHT
5	2	0901125	GREASE NIPPLE - 45°
6	4	9300144	CAPSCREW
7	1	7190292	COVER PLATE
8	4	9100205	SPRING WASHER
9	4	9313045	SETSCREW
10	2	0600018	BALL BEARING
11	1	22269.02	DRIVE HUB - QUAD DRIVE
12	1	7190022	INTERNAL CIRCLIP
13	<i>as req'd</i>	8121043	SHIM - 0.4mm
14	<i>as req'd</i>	8121044	SHIM - 0.6mm

1.2M QUAD DRIVE ROTOR MODULES

McCONEL

Module(s): 22497.01, 22497.02

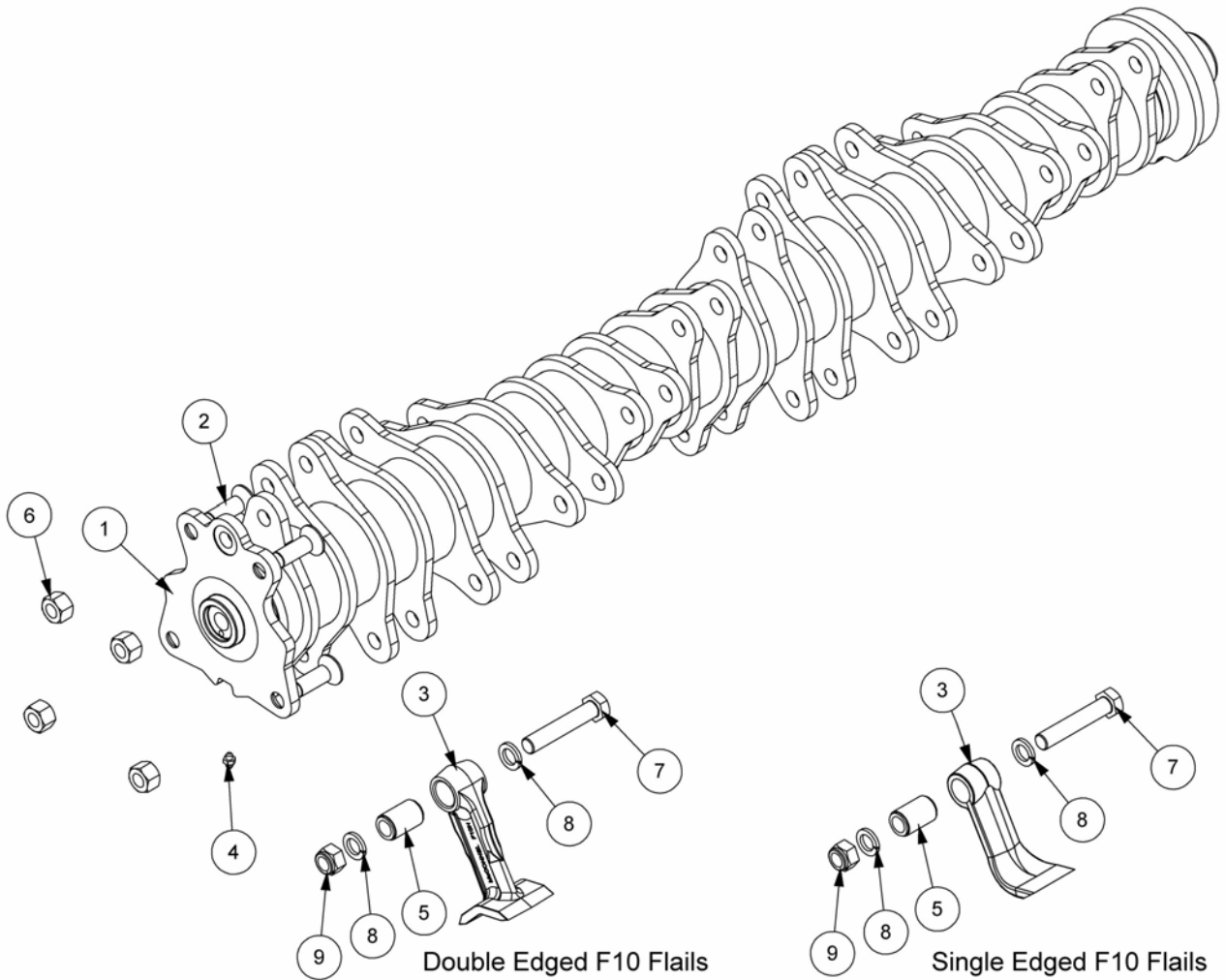

REF.	QTY.	PART No.	DESCRIPTION
		22497.01	1.2M QUAD DRIVE ROTOR (F10DE FLAILS)
		22497.02	1.2M QUAD DRIVE ROTOR (F10SE FLAILS)
1	1	22269.01	ROTOR - 1.2M QUAD DRIVE
2	4	9353097	CAPSCREW
3	24	7314366D	F10H DOUBLE EDGED FLAIL (CAST)
	24	7390276	F10 SINGLE EDGED FLAIL (CAST)
4	1	0901161	GREASE NIPPLE
5	24	7314223	FLAIL PIVOT BUSH (NARROW)
6	4	9143007	SELF-LOCKING NUT
7	24	7314201	SPECIAL BOLT (UNF)
8	48	0100206	SPRING WASHER
9	24	0141006	CLEVELOC NUT (UNF)

1.2M OMEGA QUAD DRIVE ROTOR

McCONEL

Module(s): 22269.04

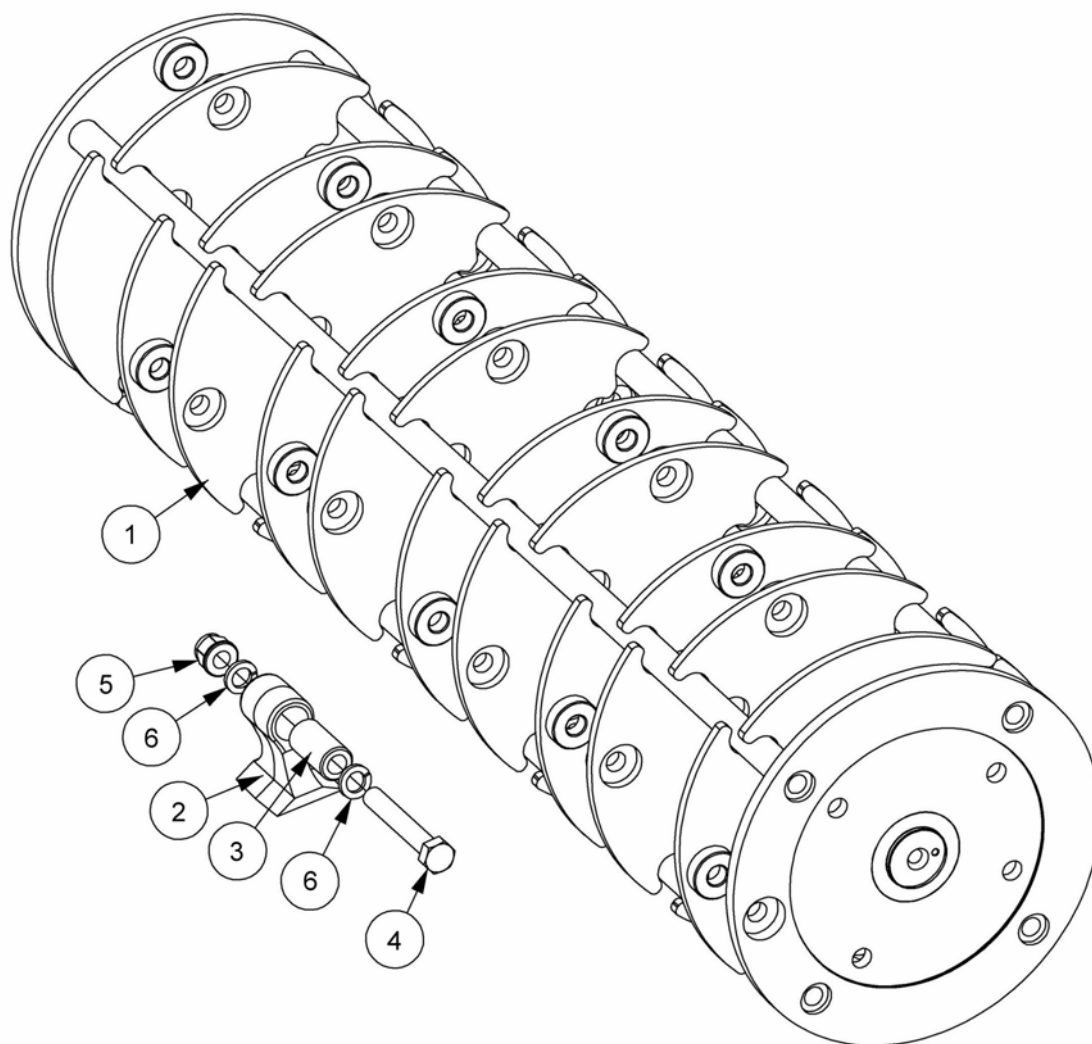

REF.	QTY.	PART No.	DESCRIPTION
			1.2M OMEGA QUAD DRIVE ROTOR
1	1	22269.04	1.2M OMEGA ROTOR
2	20	7190464	OMEGA FLAIL
3	20	7190117	FLAIL PIVOT BUSH
4	20	7390006	SPECIAL FLAIL BOLT
5	20	0141006	SELF-LOCKING NUT
6	40	0100206	SPRING WASHER

FLAIL OPTIONS & FIXINGS

McCONNEL

Module(s): Rotor Components

HEDGE

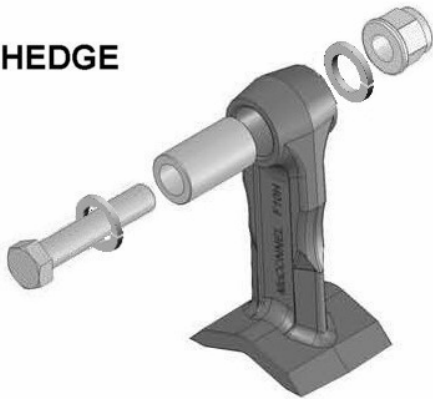

F10 D.E. Cast Flail
(Part No. 7314366D)

HEDGE

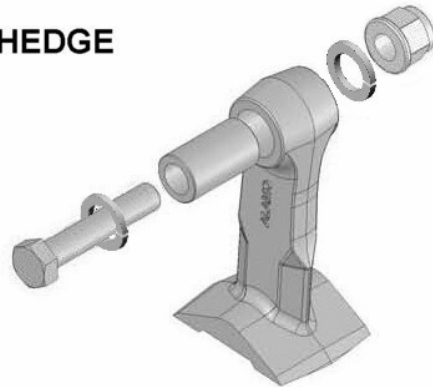

F10 D.E. Forged Flail
(Part No. 41391.02)

HEDGE

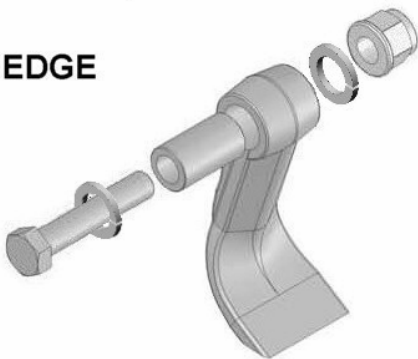

F10 S.E. Cast Flail
(Part No. 7390276)

HEDGE

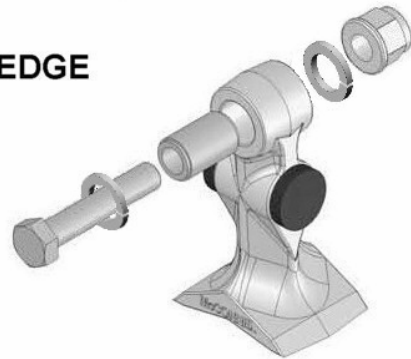

F16 D.E. Cast Flail
(Part No. 21904.02)

HEDGE

*Omega Rotor
use only*

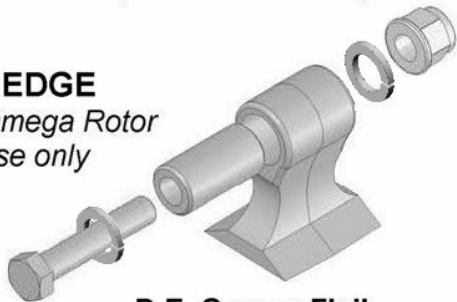

D.E. Omega Flail
(Part No. 7190464)

UNIVERSAL

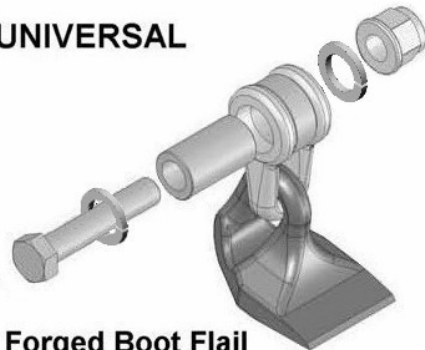

Forged Boot Flail
(Part No. 7190462)

GRASS

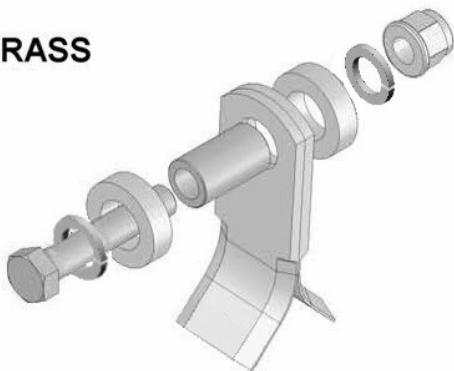

F10 Grass Flail
(Part No. 7190315)

MULTICUT FIXINGS

- Nut (9100024)
- Bush (7314223)
- Bolt (7390025)
- Shackle (7190175)

OMEGA FIXINGS

- Nut (0141006)
- Bush (7190117)
- Bolt (7390006)



COMMON FITTINGS

- Spacer (7190010)
- Spring Washer (0100206)

1.2M ROLLER ASSEMBLY

Module(s): 21523.08

McCONNEL

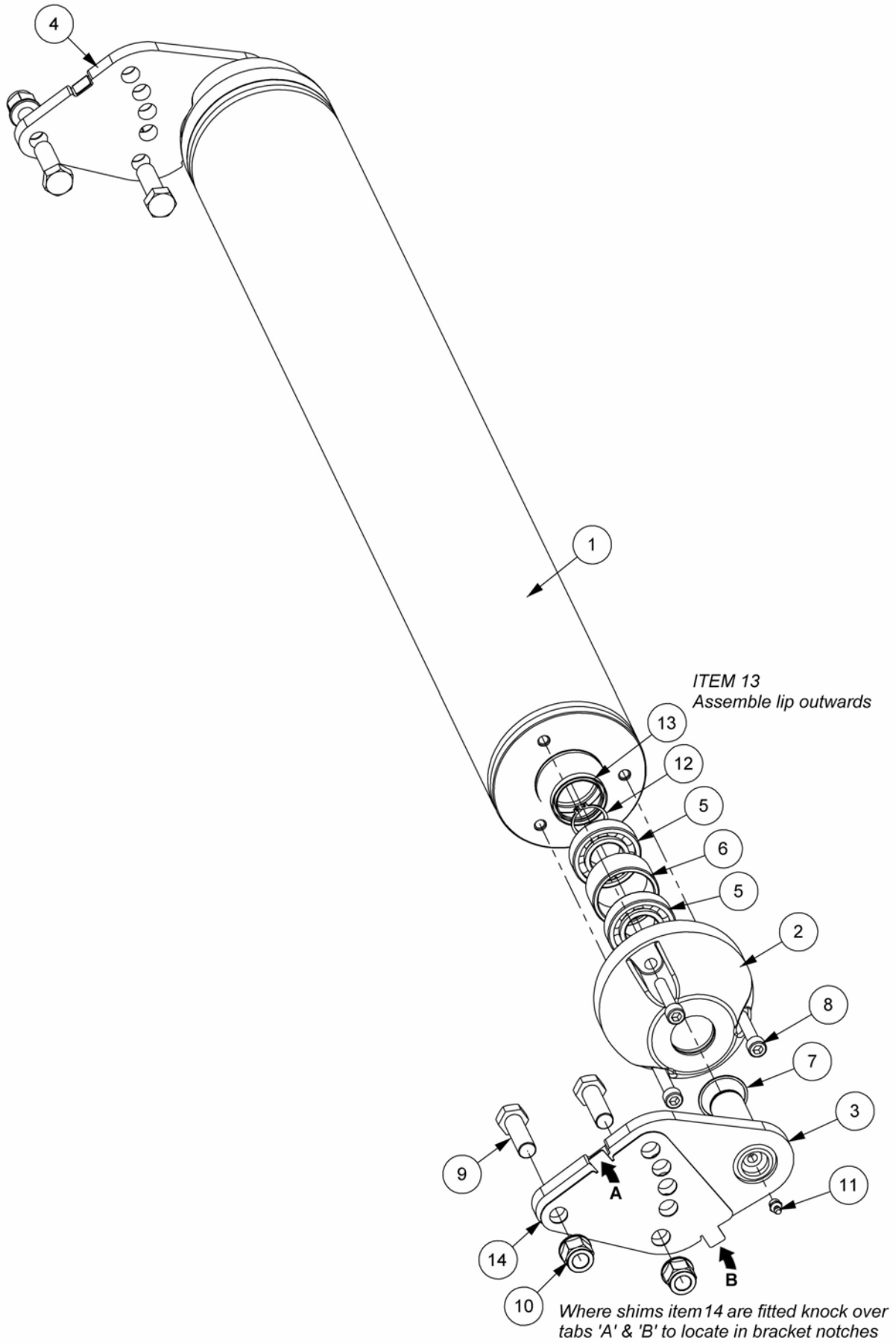

1.2M ROLLER ASSEMBLY

McCONNEL

Module(s): 21523.08

REF.	QTY.	PART No.	DESCRIPTION
		21523.08	ROLLER ASSEMBLY
1	1	21394.03	1.2M ROLLER
2	2	21394.32	ROLLER END CAP
3	1	21524.12	ROLLER BRACKET - L/H (<i>Std. Position</i>)
4	1	21524.13	ROLLER BRACKET - R/H (<i>Std. Position</i>)
5	4	0600111	BALL BEARING
6	2	21523.31	BEARING SPACER
7	2	0402240	INTERNAL SPIROLOX RING
8	6	9343105	CAPSCREW
9	4	9200025	BOLT
10	4	9100024	SELF-LOCKING FLANGE NUT
11	2	0901121	GREASE NIPPLE
12	2	0401230	EXTERNAL CIRCLIP
13	2	8629239	ROTARY SHAFT SEAL
14	<i>as req'd</i>	42257.10	SHIM - 1.2mm

Note: Roller Brackets Items 3 & 4 are swappable L/H to R/H on the roller to give various differing height settings - the illustration show the brackets assembled in the standard position with the longer edge notch upwards. When assembled the opposite way with the longer edge notch downwards it is referred to as the alternate position.

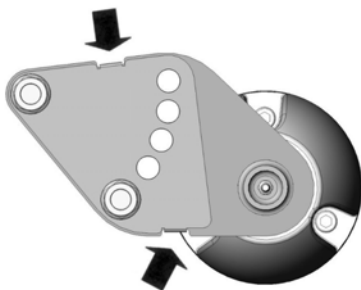

Standard Roller Position

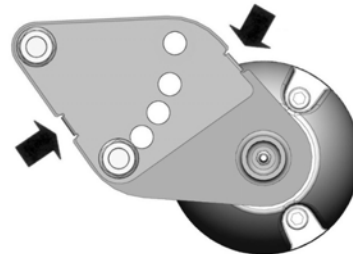

Alternate Roller Position

1.2M FRONT FLAP KIT

McCONNEL

Module(s): 7290375

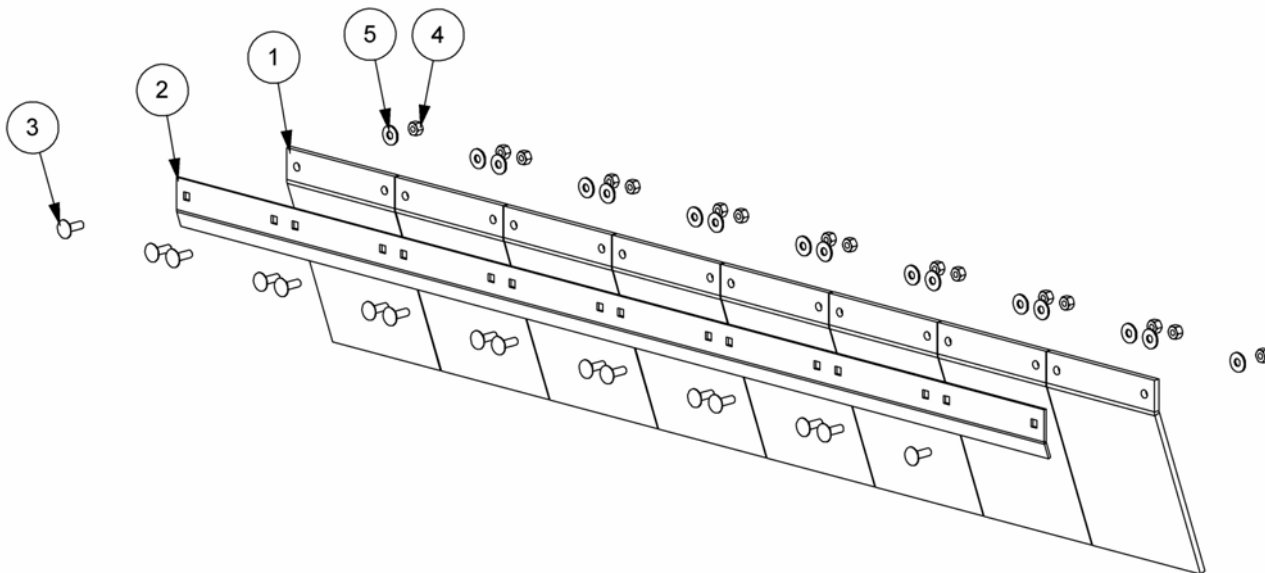

REF.	QTY.	PART No.	DESCRIPTION
		7290375	FRONT FLAP KIT
1	8	7290053	FRONT FLAP
2	1	7190304	CLAMP STRIP
3	16	9293054	CUP HEAD SCREW
4	16	9143004	SELF-LOCKING NUT
5	16	9100104	FLAT WASHER

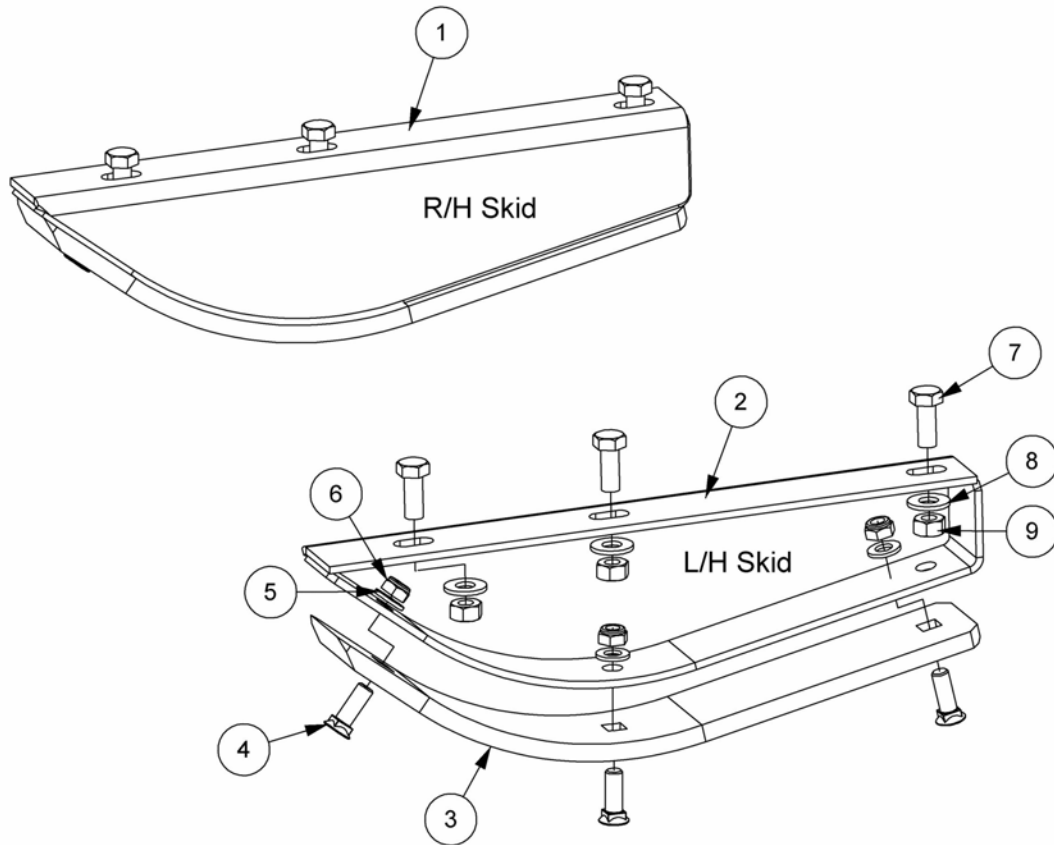

REF.	QTY.	PART No.	DESCRIPTION
		7290384	SKID KIT ASSEMBLY
1	1	7290389	SKID - R/H
2	1	7290390	SKID - L/H
3	2	7290391	REPLACEABLE SKID SHOE
4	6	6012034	PLOUGH BOLT
5	6	0100104	FLAT WASHER
6	6	0141004	SELF-LOCKING NUT
7	6	9313066	SETSCREW
8	6	9100106	FLAT WASHER
9	6	9143006	SELF-LOCKING NUT

DECAL KITS

Module(s): 7350707, 7350709, 7350711

McCONNEL



4

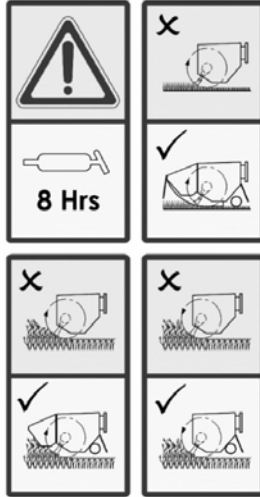

3



FLAIL PARTS INFORMATION

McConnell Flail Mowers use dynamically balanced and mated system components for Cutter Shafts, (Rotors) Knives (Flails), Knife hangers (Shackles) bolts, bushes Rollers, Drivetrain Components, Bearing Belts and Belt Pulleys. McConnell parts are made and tested to meet close-tolerance specifications of balance, quality and consistency that assure long, trouble-free service. "Will-Fit" parts do not ordinarily meet McConnell Standards and could reduce Mower performance, void warranties and present an increase in the safety hazard potential.

DON'T GAMBLE!
USE GENUINE McCONNEL SERVICE PARTS
See your McConnell dealer

5

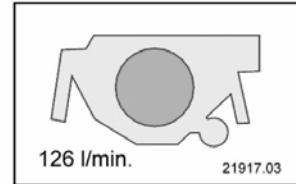

7

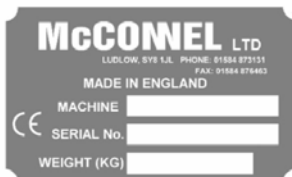
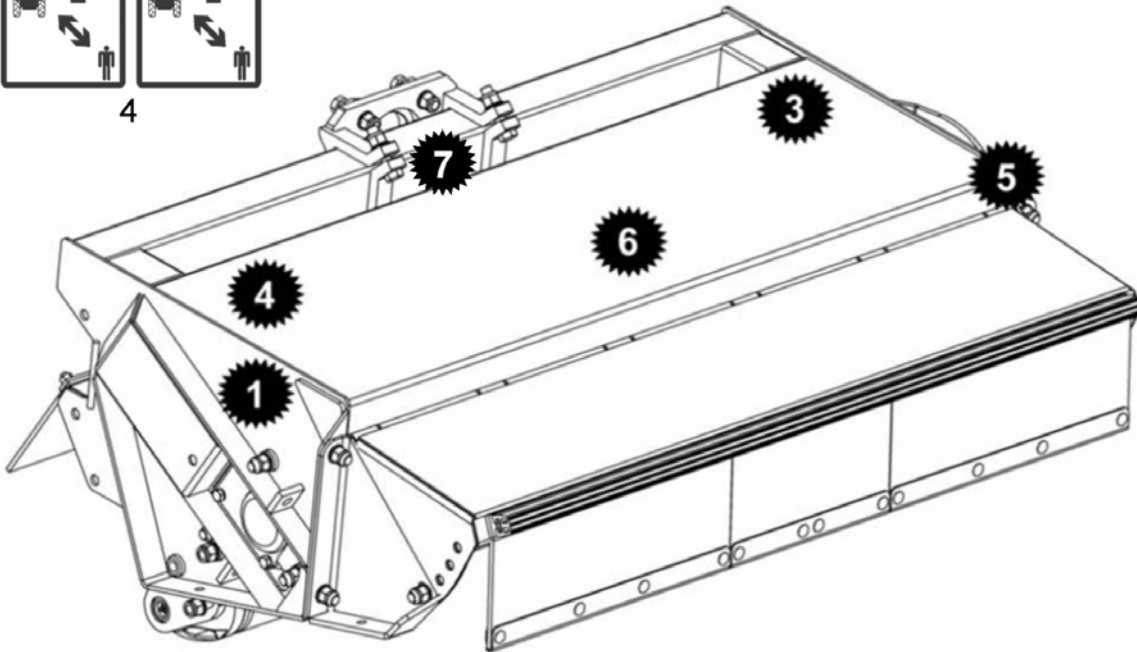

1

McCONNEL

6

DECAL KITS

McCONNEL

Module(s): 7390707, 7350709, 7350711

REF.	QTY.	PART No.	DESCRIPTION
		7350711	45HP FLAILHEAD DECAL KIT
1	1	1335246	SERIAL No. PLATE
2	4	7103230	POP RIVET
3	1	1290738	DECAL - FLAILHEAD
4	1	09.821.35	DECAL - COMBINED EURO
5	1	1290392	DECAL - PARTS
6	1	1290527	DECAL - McCONNEL
7	1	21917.01	DECAL - 78 l/min (RED)

REF.	QTY.	PART No.	DESCRIPTION
		7350707	54HP FLAILHEAD DECAL KIT
1	1	1335246	SERIAL No. PLATE
2	4	7103230	POP RIVET
3	1	1290738	DECAL - FLAILHEAD
4	1	09.821.35	DECAL - COMBINED EURO
5	1	1290392	DECAL - PARTS
6	1	1290527	DECAL - McCONNEL
7	1	21917.02	DECAL - 102 l/min (ORANGE)

REF.	QTY.	PART No.	DESCRIPTION
		7350709	65HP FLAILHEAD DECAL KIT
1	1	1335246	SERIAL No. PLATE
2	4	7103230	POP RIVET
3	1	1290738	DECAL - FLAILHEAD
4	1	09.821.35	DECAL - COMBINED EURO
5	1	1290392	DECAL - PARTS
6	1	1290527	DECAL - McCONNEL
7	1	21917.03	DECAL - 126 l/min (GREEN)



McConnel Limited, Temeside Works, Ludlow, Shropshire SY8 1JL. England.
Telephone: 01584 873131. Facsimile: 01584 876463. www.mcconnel.com