



INTERSTATER

FLAIL MOWER

Published 10/18

Part No. 803213C

OPERATOR'S MANUAL



This Operator's Manual is an integral part of the safe operation of this machine and must be maintained with the unit at all times. **READ, UNDERSTAND, and FOLLOW** the Safety and Operation Instructions contained in this manual before operating the equipment. C01-Cover_A

Important Operating and Safety Instructions are found in the Mower Safety Video that can be instantly accessed on the internet at: www.algqr.com/ave

Safety Video



www.algqr.com/ave



FCP-FL-0004

ALAMO INDUSTRIAL®

1502 E. Walnut
Seguin, Texas 78155
830-372-3551
Email: parts@alamo-industrial.com

Alamo Industrial
Web Page



www.algqr.com/ave

¡ATENCIÓN!
LEA EL INSTRUCTIVO

Si No Lee Ingles, Pida Ayuda a Alguien Que Se Lo Lea Para Que le Traduzca Las Medidas de Seguridad

MEMBER OF THE ALAMO GROUP
ALWAYS ON THE CUTTING EDGE®

! PELIGRO	! DANGER
Si no puede leer inglés: antes de poner en funcionamiento este equipo, solicite que alguien le traduzca los mensajes de seguridad o vaya al sitio web para consultar los mensajes de seguridad y las etiquetas ya traducidos.	Si vous ne savez pas lire le français: avant d'utiliser l'équipement, demandez à une personne de vous traduire les messages de sécurité ou allez sur le site Internet pour voir la traduction des autocollants et des messages de sécurité.
El Manual del Operador Seguridad vídeo	Manuel de l'Opérateur
  	 
www.algqr.com/afs www.algqr.com/avs	www.algqr.com/aff

! PERIGO	! GEFAHR
Caso você não leia inglês: antes de operar o equipamento, peça para alguém traduzir as mensagens de segurança ou visite a web e obtenha tais mensagens ou os decalques traduzidos.	Falls Sie Deutsch nicht lesen können: Lassen Sie sich, bevor Sie das Gerät in Betrieb nehmen, die Sicherheitshinweise von einer geeigneten Person in Ihre Sprache übersetzen. Oder suchen Sie auf unserer Website nach Übersetzungen von Schilderaufschriften und Sicherheitshinweisen.
Manual do Operador	Benutzerhandbuch
 	 
www.algqr.com/afp	D831 www.algqr.com/afg

Safety Video



www.algqr.com/ave

Operator's & Parts Manuals



www.algqr.com/apm

General Safety



www.algqr.com/ame

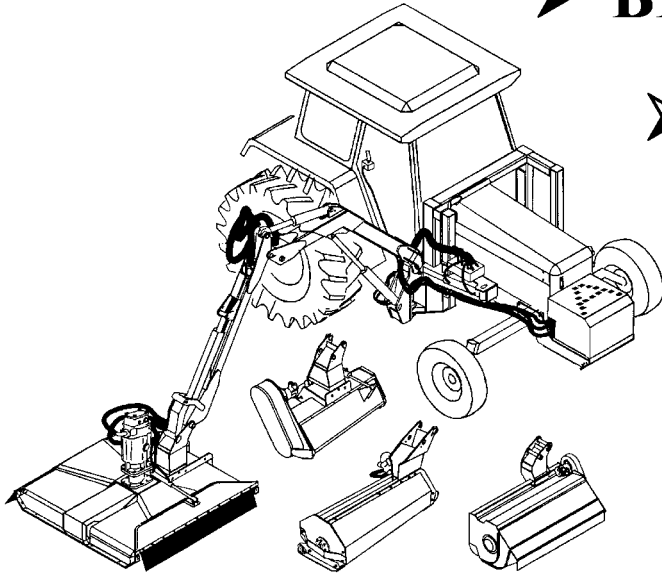

➤ **BE SAFE!**

➤ **BE ALERT!**

➤ **BE ALIVE!**

➤ **BE TRAINED**
before operating
the Mower!

Safety Video



www.algqr.com/ave



Safety Training Makes the Difference

In order to reduce accidents and enhance the safe operation of mowers, *Alamo Industrial*, in cooperation with other industry manufacturers has developed the AEM/FEMA Industrial and Agricultural Mower Safety Practices video and guide book.

The video will familiarize and instruct mower-tractor operators in safe practices when using industrial and agricultural mowing equipment. It is important that Every Mower Operator be educated in the operation of their mowing equipment and be able to recognize the potential hazards that can occur while operating a mower. This video, along with the mower operator's manual and the warning messages on the mower, will significantly assist in this important education.

Your Authorized *Alamo Industrial* Dealer may have shown this video and presented you a DVD Video when you purchased your mower. If you or any mower operator have not seen this video, **Watch the Video, Read this Operator's Manual, and Complete the Video Guidebook** before operating your new mower. If you do not understand any of the instructions included in the video or operator's manual or if you have any questions concerning safety of operation, contact your supervisor, dealer or *Alamo Industrial*.

If you would like a VHS video tape of the video, please email AEMVideo@alamo-group.com or Fax AEM VHS Video at (830) 372-9529 or mail in a completed copy of the form on the back of this page to AEM VHS Video 1502 E Walnut Street, Seguin, TX 78155. and request the VHS video version. Please include your name, mailing address, mower model and serial number.

Every operator should be trained for each piece of equipment (Tractor and Mower), Understand the intended use, and the potential hazards before operating the equipment.

The information and material listed above along with this Operator's Manual can assist you in meeting the OSHA requirement for Operator annual training.

OSHA TRAINING REQUIREMENTS

The following training requirements have been taken from Title 29, Code of Federal Regulations Part 1928.57 (a)(6). www.osha.gov

Operator Instructions. At the time of initial assignment and at least annually thereafter, the employer shall instruct every employee who operates an agricultural tractor or implement in the safe operating practices and servicing of equipment with which they are or will be involved, and of any other practices dictated by the work environment.

**Alamo Industrial Division is willing to provide
one (1) AEM Mower Safety Practices Video**

Please Send Me: VHS Format – AEM/FEMA Mower Operator Safety Video
DVD Format – AEM/FEMA Mower Operator Safety Video
Mower Operator’s Manual
AEM Mower Operator’s Safety Manual

Requester Name: _____ Phone: _____

Requester Address: _____

City: _____

State: _____

Zip Code: _____

Mower Model: _____ Serial Number: _____

Date Purchased: _____ Dealer Salesperson: _____

Dealership Name: _____ Dealership Location: _____

Mail to:

AEM Video Services
1502 E. Walnut Street
Seguin, TX 78155

Or Fax to:

(830) 372-9529

Or E-mail to:

AEMVideo@alamo-group.com

To the Owner/Operator/Dealer

This Operator's Manual is an integral part of the safe operation of this machine and must be maintained with the implement at all times. A Manual canister is provided on the implement where this manual can be properly stored. If you lose or damage this manual a free replacement manual can be obtained from an authorized *Alamo Industrial* dealer or by downloading the manual from the *Alamo Industrial* website www.alamo-industrial.com

BEFORE YOU START!! READ, UNDERSTAND, and FOLLOW the information provided in this manual, the AEM Mower Safety manual and the tractor operator's manual carefully to learn how to operate and service your machine properly. Failure to do so could result in personal injury to you and bystanders. All implements with moving parts are potentially hazardous. Every effort has been made to ensure that the machine is safe but operators must avoid engaging in unsafe practices and follow the written instructions provided. The manufacturer has designed this implement to be used with all its safety equipment properly attached to minimize the chance of accidents.

SAFETY FIRST. Completely read and understand the safety section of this manual before operating this equipment. Do not allow anyone to operate this equipment who has not fully read and understood this manual. Contact your Dealer to explain any instructions that you do not fully understand.

The care you give your *Alamo Industrial* Implement will greatly determine your satisfaction with its performance and its service life. Carefully read and follow the instructions in this manual to provide you with a thorough understanding of your new implement and its intended use and service requirements.

All references made in this manual to right, left, front, rear, top or bottom are as viewed facing the direction of forward travel with the implement properly attached to the tractor.

Replacement Parts information is located in a separate Parts Manual. *Alamo Industrial* mowers use balanced and matched system components for blade carriers, blades, cuttershafts, knives, knife hangers, rollers, drivetrain components, and bearings. These parts are made and tested to *Alamo Industrial* specifications. Non-genuine "will fit" parts do not consistently meet these specifications. The use of "will fit" parts may reduce mower performance, void warranties, and present a safety hazard. Use genuine *Alamo Industrial* mower parts for economy and safety.

For future reference, record your *Alamo Industrial* product model number and serial number.

Dealer		Telephone		Model Number	
Owner		Purchase Date:		Serial Number	



DEALER to CUSTOMER Pre-Delivery/ Operation Instructions

Dealer should inform the Purchaser of this product of Warranty terms, provisions, and procedures that are applicable. Dealer should inform Purchaser to review the contents of the Operator's Manual including safety equipment, safe operation and maintenance, to review the Safety Signs on the implement (and tractor if possible) and of Purchaser's responsibility to train his/her operators's of safe operation procedures.

- **IMPLEMENTS:** I have explained that Deflectors, Chain Guards, or Solid Skirts must be installed and maintained in good repair.
- **DRIVELINES:** I have made certain that all driveline, gearbox, and other shields are in good repair and fastened securely in place to prevent injuries from entanglement or thrown objects.
- **HYDRAULIC MACHINES:** I have explained the necessity of using clean hydraulic oil, changing filters as instructed, stopping leaks, damage caused by operating with over-heated oil, caring for hoses, using hoses of proper rating, maintaining the specified operating pressure and the potential hazard of oils penetrating the skin.
- **FOLDING-TYPE IMPLEMENTS:** I have explained that it is not possible to guard against thrown objects when the head is lifted off ground and that operator is responsible to watch out for persons in the area. I have explained that the lifted mower head or boom can contact overhead obstructions with damage to cables and telephone lines and possible injury. I have explained that the extended head or boom or retracted boom can contact power lines resulting in electrocution, injury or death and that operator is responsible for keeping clear of such hazards.

PRE-DELIVERY SERVICE CHECK AND ADJUST OR LUBRICATE AS REQUIRED See Operator's Manual for Details

Inspection Performed - Warranty and Safety Procedures Explained - Installation Complete

LUBRICATION & HYDRAULICS

- Gearbox (Oil Levels)
- Hydraulic Oil Level (External Tank)
- Tractor Hydraulic Oil Level
- Hydraulic Hoses (Not Kinked Tighten Connections)
- Front Pump Drive (Assembly Is Tight And Shaft Properly Aligned)

MOWER

- Mower Cutting Height And Level Adjusted
- Cutting Shaft Bearings Lubricated
- All Hardware Properly Torqued

ATTACHMENTS & INSTALLATION

- Deflectors Front And Rear
- Correct Blade Rotation Direction

MOWER TO TRACTOR CONNECTIONS

- A-Frame Pivot & Links
- Axle Height (Adjusted)
- Cutting Height (Adjust)
- Mount Kit-Pre-Operation Check Complete
- Mower Wing (Adjust Level With The Center)
- Mower Wing (Check For Proper Raising Operation)
- Mounting Hardware Properly Torqued

SAFETY ITEMS

- Protective Shields (Operation And Installation)
- Driveline Clutch (Torque Limiter) (Adjust And Run In)
- Safety Decals (Installed)
- Operator's Manual (Supplied)
- Tractor PTO Shield (Installed)
- S.M.V. Emblem (Installed If Needed)
- ADMA Driveline Safety Manual Supplied
- AEM Mower Safety Manual (Supplied in Canister)
- AEM Mower Safety Video has been shown to Purchaser

Table of Contents

SAFETY SECTION	1-1
GENERAL SAFETY INSTRUCTIONS AND PRACTICES	1-2
OPERATOR SAFETY	1-3
CRUSHING HAZARDS	1-4
CONNECTING OR DISCONNECTING IMPLEMENT SAFETY	1-5
THROWN OBJECTS HAZARDS	1-6
THROWN OBJECTS HAZARD (CONTINUED)	1-7
RUN OVER HAZARDS	1-8
PTO ENTANGLEMENT HAZARDS	1-9
MOWER BLADE CONTACT HAZARDS	1-10
HIGH PRESSURE OIL LEAK HAZARD	1-11
ELECTRICAL & FIRE HAZARDS	1-12
TRANSPORTING HAZARDS	1-13
HAZARDS WITH MAINTENANCE OF IMPLEMENT	1-14
PARTS INFORMATION	1-15
Decal Location	1-16
Decal Description	1-18
Federal Laws and Regulations	1-28
INTRODUCTION SECTION	2-1
ASSEMBLY SECTION	3-1
GENERAL INSTRUCTIONS	3-2
PRELIMINARY TRACTOR PREPARATION	3-3
SPECIAL TOOLS	3-3
DRIVE COUPLING ATTACHMENT	3-4
HYDRAULIC TANK, SUPPORTS AND MAINFRAME ATTACHMENT	3-4
MOUNTING AND PUMP ASSEMBLY	3-5
LIFT CYLINDER FRAME ATTACHMENT	3-5
MOUNTING WING MOWERS	3-6
ELECTRICAL WIRING INSTALLATION	3-8
ELECTRICAL CIRCUIT	3-9
CONTROL VALVE	3-11
HYDRAULICS	3-12
CONTROL CABLE CONNECTION TO CONTROL STICK ASSEMBLIES	3-19
INITIAL START-UP PROCEDURE	3-20
FINAL CHECK	3-21
INSTALLATION OF REAR MOWER	3-22
OPERATION SECTION	4-1
Standard Equipment and Specifications	4-3
OPERATOR REQUIREMENTS	4-4
TRACTOR REQUIREMENTS	4-5
ROPS and Seat Belt	4-5
Tractor Safety Devices	4-5
Tractor Horsepower	4-5
GETTING ON AND OFF THE TRACTOR	4-6
Boarding the Tractor	4-6
Dismounting the Tractor	4-7
STARTING THE TRACTOR	4-8

CONNECTING THE MOWER TO THE TRACTOR	4-8
Connecting the Mower A-Frame to the Tractor	4-9
SETTING THE MOWER	4-10
Roller Height Adjustment	4-11
Leveling Deck	4-12
DRIVELINE ATTACHMENT	4-12
Driveline Length Check	4-12
PRE-OPERATION INSPECTION AND SERVICE	4-14
Tractor Pre-Operation Inspection/Service	4-16
Mower Pre-Operation Inspection/Service	4-16
DRIVING THE TRACTOR AND IMPLEMENT	4-22
Starting the Tractor	4-23
Brake and Differential Lock Setting	4-23
Operating the Mower Wings	4-24
Engaging and Disengaging the Power Take Off (PTO) and Wings	4-26
Driving the Tractor and Implements	4-27
Crossing Ditches and Steep Inclines	4-28
OPERATING THE TRACTOR AND IMPLEMENT	4-29
Foreign Debris Hazards	4-30
Bystanders/Passersby Precautions	4-30
PTO RPM and Ground Speed	4-31
Operating the Mower	4-32
Shutting Down the Implement	4-33
DISCONNECTING THE MOWER FROM THE TRACTOR	4-34
MOWER STORAGE	4-35
TRANSPORTING THE TRACTOR AND IMPLEMENT	4-36
Transporting on Public Roadways	4-37
Hauling the Tractor and Implement	4-39
TROUBLE SHOOTING GUIDE	4-42

MAINTENANCE SECTION 5-1

HAZARDS WITH MAINTENANCE OF IMPLEMENT	5-2
PARTS INFORMATION	5-3
DAILY CHECKS	5-3
ADJUSTING TENSION OF DRIVEBELTS	5-5
Hydraulic Fluid	5-5
Proper Oil Level	5-7
CHANGING HYDRAULIC SYSTEM FILTER	5-7
CUTTER UNIT	5-9
GENERAL MAINTENANCE	5-9
REPLACING CUTTER UNIT DRIVEBELTS	5-10
ADJUSTING CUTTING HEIGHT	5-10
ROLLER BEARING REPLACEMENT	5-11
CUTTERSHAFT BEARING REPLACEMENT	5-12
Outboard Bearing	5-12
Inboard (Drive) Bearing	5-13
CUTTERSHAFT REPLACEMENT	5-13
CHANGING TO FORWARD OR REVERSE ROTATION	5-14
Wing Mowers	5-14
Rear Mower	5-14
REPLACING CUTTER UNIT KNIVES	5-14
Flail Blades Inspection	5-15
Blade Pins and D-Ring Inspection	5-16
General Information on Flail Mower Vibration	5-17
HYDRAULICS	5-18

General	5-18
Initial Start-Up Procedures	5-18
POWER CIRCUIT	5-20
Replacing Hydraulic Pumps	5-20
Replacing Outer Pump	5-20
Solenoid Control Valve	5-21
Checking Solenoid Valve	5-21
Hydraulic Pump	5-21
CONTROL CIRCUIT	5-27
Lift and Tilt Cylinders	5-27
Disassembly or Lift or Tilt Cylinder	5-27
Cylinder Rod Maintenance	5-27
Hydraulic Component Maintenance Schedule	5-28
Hydraulic Gear Pump	5-28
Sectional Control Valve	5-29
Checking Relief Valve Pressure	5-29
External Coil Slip Disk Replacement	5-30
Slip Clutch	5-31
SEASONAL CLUTCH MAINTENANCE	5-32
Proper Torque for Fasteners	5-33

SAFETY SECTION

Safety Section 1-1

SAFETY

GENERAL SAFETY INSTRUCTIONS AND PRACTICES

A careful operator is the best operator. Safety is of primary importance to the manufacturer and should be to the owner/operator. Most accidents can be avoided by being aware of your equipment, your surroundings, and observing certain precautions. The first section of this manual includes a list of Safety Messages that, if followed, will help protect the operator and bystanders from injury or death. Read and understand these Safety Messages before assembling, operating or servicing this implement. This equipment should only be operated by those persons who have read the manual, who are responsible and trained, and who know how to do so responsibly.



The Safety Alert Symbol combined with a Signal Word, as seen below, is used throughout this manual and on decals which are attached to the equipment. The Safety Alert Symbol means: "ATTENTION! BECOME ALERT! YOUR SAFETY IS INVOLVED!" The Symbol and Signal Word are intended to warn the owner/operator of impending hazards and the degree of possible injury faced when operating this equipment.

Practice all usual and customary safe working precautions and above all--- remember safety is up to YOU. Only YOU can prevent serious injury or death from unsafe practices.



Indicates an imminently hazardous situation that, if not avoided, WILL result in DEATH OR VERY SERIOUS INJURY.



Indicates an imminently hazardous situation that, if not avoided, COULD result in DEATH OR SERIOUS INJURY.



Indicates an imminently hazardous situation that, if not avoided, MAY result in MINOR INJURY.





Identifies special instructions or procedures that, if not strictly observed, could result in damage to, or destruction of the machine, attachments or the environment.

NOTE: *Identifies points of particular interest for more efficient and convenient operation or repair.*

READ, UNDERSTAND, and FOLLOW the following Safety Messages. Serious injury or death may occur unless care is taken to follow the warnings and instructions stated in this Manual and in the Safety Messages on the implement. Always follow the instruction in this manual and use good common sense to avoid hazards.



Pictographs are used throughout this manual to help bring your visual attention to safety issues.

SAFETY HAZARD	SAFETY AVOIDANCE	SAFETY PREVENTION
<p>Pictograph surrounded by a triangle indicates a Safety Hazard that must be avoided.</p> <p style="text-align: center;"><i>Example:</i></p>  <p style="text-align: center;">Equipment contacting overhead electrical lines</p>	<p>Pictograph by itself or inside a box indicates an avoidance procedure that should be followed to prevent injuries.</p> <p style="text-align: center;"><i>Example:</i></p>  <p style="text-align: center;">Always shut off engine and remove key before working on equipment.</p>	<p>A circle with a slash through it indicates an action that is prohibited.</p> <p style="text-align: center;"><i>Example:</i></p>  <p style="text-align: center;">No Smoking</p>

NOTE: *If you want a translation of this safety section in one of the following Languages, please contact: Translations at 1502 E. Walnut Street Seguin, TX 78155; Fax: (830) 372-9529; Safety Section Translations are available in Spanish, Portuguese, French, German, Russian. PN 6S01*

SAFETY

OPERATOR SAFETY

				
Read and understand Operator's Manual	Always wear Safety Glasses	Wear Hard Hat Safety Shoes	Never use Drugs or Alcohol when operating equipment	Wear Safety Vest when operating on or near roads



TO AVOID SERIOUS INJURY OR DEATH DO THE FOLLOWING:

- **READ, UNDERSTAND** and **FOLLOW** Operator's Manual instructions, Warnings and Safety Messages.
- **WEAR SAFETY GLASSES**, safety shoes, hard hat, hearing protection and gloves when operating or repairing equipment
- **WEAR** appropriate breathing respirator when operating in dusty conditions to avoid respiratory diseases.
- **DO NOT WEAR** loose clothing or jewelry to avoid rotating parts entanglement injury.
- **DO NOT USE DRUGS** or **ALCOHOL** before or while operating equipment.
- **DO NOT ALLOW** anyone to operate equipment under the influence of drug or alcohol.
- **CONSULT** medical professional for medication impairment side effects.
- **STAY ALERT**, prolonged operation can cause fatigue, **STOP** and **REST**.

GENERAL OPERATING SAFETY

VISIBILITY CONDITIONS WHEN MOWING:

- **OPERATE IN DAYLIGHT** or with lights that gives at least 100 yards clear visibility.
- **BE ABLE TO SEE** and identify passersby, steep slopes, ditches, drop-offs, overhead obstructions, power lines, debris and foreign objects.

GROUND SPEED WHEN MOWING:

- **NORMAL SPEED** range is between 2 to 5mph.
- **ADJUST MOWING SPEED** for terrain conditions and grass type, density and cut height.
- **REDUCE MOWING SPEED** when near steep slopes, ditches, drop-offs, overhead obstructions, power lines and to avoid debris and foreign objects.

INSECT INFESTATION

- Do Not operate in areas where bees or insects may attack unless you **WEAR PROTECTIVE CLOTHING** or use enclosed tractor cab.

PTO SPEED:



- **DO NOT EXCEED IMPLEMENT RATED PTO SPEED**
- **AVOID** exceeding rated PTO speeds that may result in broken drivelines or blade failures.

SAFETY SIGNS:

- **REPLACE** missing, damaged or unreadable safety signs immediately. *PN OS01*

SAFETY

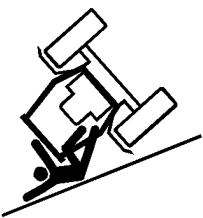
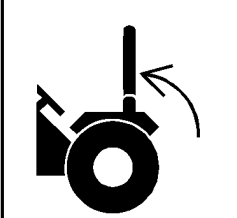
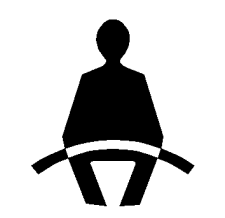
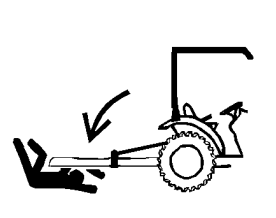
CRUSHING HAZARDS

				
Crushing injury from roll over	Lock ROPS in up position	Always wear seatbelt	Crushing injury implement falling	Crushing injury wing falling

⚠ DANGER

TO AVOID SERIOUS INJURY OR DEATH FROM FALLING OFF TRACTOR, EQUIPMENT RUN OVER, ROLLOVER AND CRUSHING BY FALLING WING OR IMPLEMENT:

- USE ROPS and SEAT BELT equipped tractors for mowing operations.
- KEEP ROPS lock in up position.
- ALWAYS BUCKLE UP seat belt when operating tractor and equipment.
- ONLY OPERATE tractor and equipment while seated in tractor seat.

WHEN RAISING OR LOWERING WINGS:

- Raise or lower ONLY WHILE SEATED in tractor seat with seat belt buckled.
- KEEP BYSTANDERS CLEAR of area TO AVOID crushing.
- KEEP sufficient clearance around implement and wings TO AVOID contacting buildings or overhead power lines.

LIFTED Equipment can fall from mechanical or hydraulic failure or inadvertent Control Lever movement.

⚠ WARNING

TO AVOID EQUIPMENT FALLING while working near or under lifted wings, components and implements raised by 3-Pointed tractor hitch:

- SECURELY SUPPORT or block up raised equipment, wings and components.
- BLOCK UP and securely support equipment before putting hands, feet or body under raised equipment or lifted components.
- KEEP BYSTANDERS CLEAR of folded wings until wings are blocked or locked up.

WHEN PARKING Implement and Tractor:

- LOWER implement, LOCK or BLOCK lifted parts before leaving equipment.
- NEVER leave implement unattended in a raised position.

⚠ WARNING

TO AVOID CHILDREN FALLING OFF OR BEING CRUSHED BY EQUIPMENT:

- NEVER ALLOW children to play on or around Tractor or Implement.

WHEN UNHITCHING IMPLEMENT:



- LOWER implement, LOCK or BLOCK lifted parts before leaving equipment.

BEFORE REMOVING Wing Retaining Lock:

- ATTACH hoses to tractor.
- FILL Wing Cylinders with oil. (*Refer to Instructions in Operation Section*)
- KEEP bystanders away before operating wings.
- LOWER WINGS slowly and carefully. PN CHFM-03

SAFETY

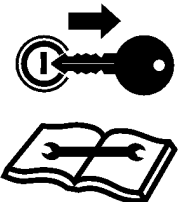
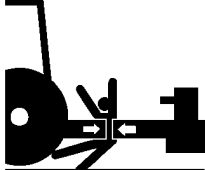
CONNECTING OR DISCONNECTING IMPLEMENT SAFETY

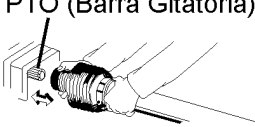
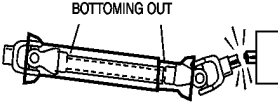
				
<p>Stop Tractor Remove Key Read Manual</p>	<p>Crushing injury between tractor and implement</p>	<p>Crushing injury wing falling</p>	<p>Make sure PTO shaft is securely attached to tractor</p>	<p>Make sure PTO shaft are proper length</p>



TO AVOID SERIOUS INJURY OR DEATH FROM BEING CRUSHED BY TRACTOR OR IMPLEMENT:

WHEN BACKING tractor to implement hitch:

- **DO NOT ALLOW BYSTANDERS** between tractor and implement.

BEFORE connecting and disconnecting implement hitch:

- **STOP TRACTOR ENGINE**, place transmission into park, engage parking brake and remove key.

WHEN connecting and disconnecting implement hitch:

- **DO NOT** crawl or walk under raised mower or wing.

WHEN CONNECTING IMPLEMENT DRIVELINE:

TO AVOID implement driveline coming loose during operation:

- **LUBRICATE** yoke spring locking collar to ensure it freely slides on PTO shaft.
- **SECURELY** seat yoke locking balls in PTO shaft groove.
- **PUSH** and **PULL DRIVELINE** on both the tractor and implement **PTO SHAFTS** to ensure it is **SECURELY ATTACHED**.

TO AVOID broken driveline during operations:

- **CHECK** driveline for proper length between PTO shaft and implement gearbox shaft. *(Refer to Instructions in Operation Section)*
- Drivelines too short can pull apart or disengage.
- Drivelines too long can bottom out.
- Bottoming driveline telescoping assembly will stop sliding and become solid.
- Driveline bottoming can push through support bearings and break off PTO shaft.

CONTACT DEALER if implement driveline does not match Tractor PTO shaft:

- **DO NOT USE PTO ADAPTER.**
Using a PTO adapter can cause:
 - Excessive vibration, thrown objects, blade and implement failures by doubling operating speed.
 - Increased working length exposing unshielded driveline areas and entanglement hazards.

BEFORE REMOVING WING RETAINING LOCKS:



- **FILL** Wing Cylinders with oil. *(Refer to Instructions in Operation Section)*
- **KEEP** bystanders clear of area before operating wings.
- **LOWER WINGS** slowly and carefully.

DO NOT connect the Mower to a tractor with the PTO directly connected to the Tractor transmission. *PN CDFM-03*

SAFETY

SAFETY

THROWN OBJECTS HAZARDS

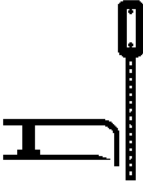
			
Mower Thrown Objects Hazard	Raised Mower Thrown Objects	Inspect Area remove foreign objects	Do not let blades contact solid objects



ROTARY MOWERS CAN THROW OBJECTS 300 FEET OR MORE UNDER ADVERSE CONDITIONS.

TO AVOID SERIOUS INJURY OR DEATH TO OPERATOR OR BYSTANDERS FROM THROWN OBJECTS:

- KEEP bystanders 300 feet away

STOP MOWING IF PASSERSBY ARE WITHIN 300 FEET UNLESS:

- **All THROWN OBJECT SHIELDING** including, Front and Rear Deflectors, Steel Guards, Bands, Side Skirts and Skid Shoes in place and in good condition when mowing.
- Mower sections or wing are adjusted to be close and parallel to ground without exposing blades.
- **MOWING AREA** has been inspected and foreign materials and debris have been removed.
- **PASSERSBY** are inside enclosed vehicle.

INSPECT AREA FOR POTENTIAL THROWN OBJECTS BEFORE MOWING:

- **REMOVE** debris, rocks, wire, cable, metal objects and other foreign material from area.
Wire, cable, rope, chains and metal objects can be thrown or swing outside deck with great velocity:
DO NOT allow the mower blades to contact decaying animal carcasses or other hazardous materials. The mower blades could throw hazardous and biologic material out from under mower exposing the operator and bystanders to health risks. Always wear required OSHA approved Personal Protective Equipment (PPE) when cleaning or removing potentially hazardous material from equipment.
 1. **MARK** objects that cannot removed.
 2. **AVOID** these objects when mowing.

HIGH GRASS and WEED AREA INSPECTION:

- **INSPECT** for and **REMOVE** any hidden large debris.
- **MOW** at Intermediate height
- **INSPECT** and remove remaining debris
- **MOW** at final height.

MOWER THROWN OBJECT SHIELDING:



- **KEEP** all thrown object shielding including, Front and Rear Deflectors, Steel Guards, Bands, Side Skirts and Skid Shoes in place and in good condition when mowing.
- **DO NOT OPERATE** with any thrown object shielding missing, damaged or removed.

RIGHT OF WAY (Highway) MOWING

- No shielding is 100% effective in preventing thrown objects. To Reduce Possibility of Injury:
 1. **MAINTAIN MOWER SHIELDING**, side skirts, skid shoes, and blades in good operational condition,
 2. **RAISE CUTTING HEIGHT** to **6 INCHES** minimum,
 3. **INSPECT AREA** thoroughly before mowing to **REMOVE** potential **THROWN OBJECT HAZARDS**,
 4. **NEVER ALLOW BLADES** to **CONTACT SOLID OBJECTS** like wire, rocks, post, curbs, guardrails, or ground while mowing. *PN TOFM-01*

SAFETY

THROWN OBJECTS HAZARD (CONTINUED)

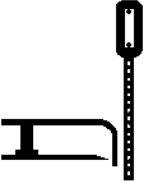
			
<p>Mower Thrown Objects Hazard</p>	<p>Raised Mower Thrown Objects</p>	<p>Inspect Area remove foreign objects</p>	<p>Do not let blades contact solid objects</p>

MOWER OPERATION:

- **DO NOT** exceed mower's rated Cutting Capacity or cut non-vegetative material.
- **USE ENCLOSED TRACTOR CABS** when two or more mowers are operating in mowing area.
- **ADJUST** mower sections or wing close and parallel to ground without exposing blades
- **ADJUST** cutting **HEIGHT** to **AVOID BLADE CONTACT** with solid objects like wire, rocks, posts, curbs, guard rails and fixed obstructions.
- **DO NOT** operate mower when mower is raised or in transport position
- **STOP MOWING** immediately if blades strike heavy objects, fixed structures, metal guard rails and concrete structures:
 1. **BLADES CAN FAIL** from impact and objects can be thrown with great velocity.
 2. **INSPECT** and **REPLACE** any damaged blades.
 3. **CHECK** blade carrier balance and **REPLACE** if damaged.
- **DO NOT** mow in standing water **TO AVOID** possible **BLADE FAILURE**.
- **AVOID MOWING** in reverse:
 1. **STOP PTO** and back up mower.
 2. **LOWER** mower, engage **PTO** and mow forward.
- **STOP PTO** and **BLADES** when raising the mower to transport position.
- **DO NOT ENGAGE PTO** with mower in transport position.
- **STOP** mowing when **EXCESSIVE VIBRATION** occurs:
 1. **STOP PTO** and tractor **ENGINE**.
 2. **INSPECT** mower for vibration source
 3. **REPLACE** any damage parts and bent or damaged **BLADES**. *PN TOFM-02*

SAFETY

SAFETY

RUN OVER HAZARDS

		
Operator run over hazard	Rider fall off run over hazard	Rider fall off run over hazard



TO AVOID SERIOUS INJURY OR DEATH FROM FALLING OFF TRACTOR OR EQUIPMENT RUN OVER:



- **USE ROPS** and **SEAT BELT** equipped tractors for mowing operations.
- **KEEP ROPS** locked in **UP** position.
- **ONLY** start tractor while seated in tractor seat.
- **ALWAYS BUCKLE UP** seat belt when operating tractor and equipment.
- **ONLY OPERATE** tractor and equipment while seated in tractor seat.
- **NEVER ALLOW RIDERS** on tractor or implement.

WHEN MOUNTING AND DISMOUNTING TRACTOR:

- **ONLY** mount or dismount when tractor and moving parts are stopped.
- **STOP ENGINE AND PTO**, engage parking brake, lower implement, allow all moving parts to stop and remove key before dismounting from tractor. *PN R001*

SAFETY

PTO ENTANGLEMENT HAZARDS

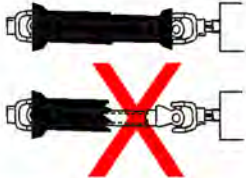
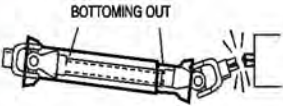
	 <p>PTO (Barra Gitatoria)</p>		 <p>BOTTOMING OUT</p>
<p>Entanglement hazard Do Not approach or touch a rotating PTO driveshaft</p>	<p>Make sure PTO shaft is securely attached Do Not Use PTO Adapter</p>	<p>DO NOT Operate if PTO shields are damaged or missing</p>	<p>Make sure PTO shafts are proper length</p>



KEEP AWAY FROM ROTATING DRIVELINES AND ELEMENTS TO AVOID SERIOUS INJURY OR DEATH:

STAY AWAY and **KEEP** hands, feet and body **AWAY** from rotating blades, drivelines and parts until all moving elements have stopped.

- **STOP, LOOK** and **LISTEN** before approaching the mower to make sure all rotating motion has stopped.
- **ROTATING COMPONENTS CONTINUE** to **ROTATE** after the PTO is shut off.

PTO SHIELDING:

TO AVOID SERIOUS INJURY OR DEATH FROM ENTANGLEMENT WHEN OPERATING IMPLEMENT:

- **KEEP PTO** shields, integral driveline shields and input shields installed
- **DO NOT OPERATE** mower without shields and guards in place or missing
- **REPAIR OR REPLACE** if damage, broken or missing
- **ALWAYS REPLACE GUARDS** that have been removed for service or maintenance.
- Do Not use PTO or PTO guard as a step.

TO AVOID broken driveline during operations:

- **CHECK** driveline for proper length between PTO shaft and implement gearbox shaft. *(Refer to Instructions in Operation Section)*
- Drivelines too short can pull apart or disengage.
- Drivelines too long can bottom out.
Bottoming driveline telescoping assembly will stop sliding and become solid.
- Driveline bottoming can push through support bearings and break off PTO shaft
- **AVOID** sharp turns or lift mower to heights to cause driveline "knocking".
- Lubricate driveshaft-telescoping components weekly.

CONTACT DEALER if implement driveline does not match Tractor PTO shaft:

- **DO NOT USE PTO ADAPTER.**

Using a PTO adapter can cause excessive vibration, thrown objects, blade and implement failures by doubling operating speed. Increased working length exposing unshielded driveline areas. **PN PE01**

SAFETY

SAFETY

MOWER BLADE CONTACT HAZARDS

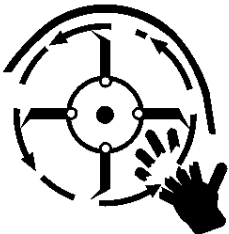
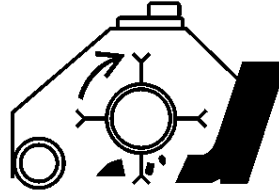
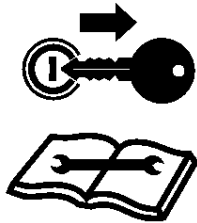
		
Do not put fingers underneath mower	Do not put foot underneath mower	Stop Tractor Remove Key Read Manual

⚠ DANGER





KEEP AWAY FROM ROTATING BLADES TO AVOID SERIOUS INJURY OR DEATH FROM BLADE CONTACT:

- **STAY AWAY** and **KEEP HANDS, FEET** and **BODY AWAY** from rotating blades, drivelines and parts until all moving elements have stopped.
- **DO NOT** put hands or feet under mower decks
- **STOP** rotating **BLADES** disengage PTO and wait for blade to stop rotating before raising mower deck or wings
- **STOP LOOK** and **LISTEN** before approaching the mower to make sure all rotating motion has stopped. *PN MBFM-01*

SAFETY

SAFETY

HIGH PRESSURE OIL LEAK HAZARD

			
High pressure oil penetrating skin	High pressure oil eroding skin	Using cardboard to check for oil leaks	Tank contents under pressure. Allow oil to cool before slowly removing cap



TO AVOID SERIOUS INJURY OR DEATH FROM HIGH PRESSURE HYDRAULIC OIL LEAKS PENERATING SKIN:

- **DO NOT OPERATE** equipment with oil or fuel leaks.
- **KEEP** all hydraulic hoses, lines and connections in **GOOD CONDITION** and **TIGHT** before applying system pressure.
- **RELIEVE HYDRAULIC PRESSURE** before disconnecting lines or working on the system.
- **REMOVE** and replace hose if you suspect it leaks. Have dealer test it for leaks.

HIGH PRESSURE FLUID LEAKS CAN BE INVISIBLE.

WHEN CHECKING FOR HYDRAULIC LEAKS AND WORKING AROUND HYDRAULIC SYSTEMS:

- **ALWAYS WEAR** safety glasses and impenetrable gloves.
- **USE** paper or cardboard to search for leaks.
- **DO NOT USE** hands or body parts to search for leak.
- **KEEP** hands and body **AWAY** from pin holes and nozzles ejecting hydraulic fluid.
- Hydraulic fluid may cause gangrene if not surgically removed immediately by a doctor familiar with this form of injury.

Use Caution when removing Hydraulic Tank cap.



- Tank content maybe under pressure.
- Allow oil to cool before removing cap.
- Relieve oil pressure before removing cap slowly.
- Stay away from hot oil that may spray from tank.

PN HPFM-01

SAFETY

SAFETY

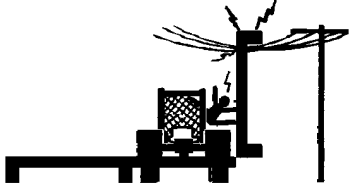
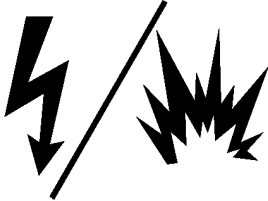
ELECTRICAL & FIRE HAZARDS

		
Wing contacting overhead electrical lines	Strike and explosion Hazard Blades Contacting Utility or Gas Lines	Do not operate near fires. Keep mower deck clear of debris

⚠ DANGER TO AVOID SERIOUS INJURY OR DEATH FROM ELECTRICAL CONTACT WHEN WORKING AROUND ELECTRICAL POWER LINES, GAS LINES AND UTILITY LINES:





- **INSPECT** mowing area for overhead or underground electrical power lines, obstructions, gas lines, cables and Utility, Municipal, or other type structure.
- **KEEP** all raised wings at a 10 feet or greater distance from all power lines and overhead obstructions.
- **DO NOT** allow mower to contact with any Utility, Municipal, or type of structures and obstructions.
- **CALL 811** and 1-800-258-0808 for identify buried utility lines.

FIRE PREVENTION GUIDELINES while Operating, Servicing, and Repairing Mower and Tractor to reduce equipment and grass fire Risk:

- **EQUIP** Tractor with a **FIRE EXTINGUISHER**
- **DO NOT OPERATE** mower on a tractor equipped with under frame exhaust
- **DO NOT SMOKE** or have open flame near Mower or Tractor
- **DO NOT DRIVE** into burning debris or freshly burnt area
- **AVOID FIRE IGNITION** by not allowing mower blade to contact solid objects like metal or rock.
- **ADJUST SLIP CLUTCHES** to avoid excessive slippage and clutch plate heating.
- **CLEAR** any grass clippings or debris buildup around mower drivelines, slip clutches, and gearboxes.
- **SHUT OFF ENGINE** while refueling.
- Do not operate if oil is leaking. Repair oil leak and remove all accumulated oil before operating.
- **CLEAR** any grass clippings or debris buildup around mower hydraulic pumps, valves or tanks. *PN EFFM-01*

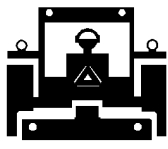
SAFETY

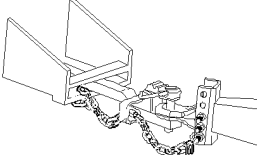
TRANSPORTING HAZARDS

				
Use SMV signs and Flashing Lights	Loss of Control Stopping Hazard	Loss of Control Speeding Hazard	Use Safety Tow Chain - Tractor to Implement	Engage Transport Locks

WARNING

TO AVOID SERIOUS INJURY AND DEATH WHEN TOWING OR TRANSPORTING EQUIPMENT:

- **KEEP** transport speed **BELOW** 20 mph to maintain control of equipment.
- **REDUCE SPEED** on inclines, on turns and in poor towing conditions.
- **DO NOT TOW** with trucks or other vehicles.
- **USE** only properly sized and equipped tractor for towing equipment.
- **FOLLOW** all local traffic regulations.

TRACTOR REQUIREMENTS FOR TOWING OR TRANSPORTING IMPLEMENTS:

- **ONLY TRANSPORT** with tractor with **ROPS** in the raised position.
- **USE** properly sized and equipped tractor that exceeds implement weight by at least 20%.
- **KEEP** 20% of tractor weight on front wheels to maintain safe steering.

BEFORE TRANSPORTING OR TOWING IMPLEMENT:

TRACTOR INSPECTION:

- **CHECK** steering and braking for proper operation and in good condition.
- **CHECK SMV** sign, reflectors, stop lights, tail lights and hazard lights for proper operation and visibility behind unit.
- **CHECK** that your driving vision is not impaired by tractor, cab, or implement while seated in tractor seat.
- **ADJUST** your operating position, mirrors, and implement transport for clear vision for traveling and traffic conditions.

PREPARE IMPLEMENT FOR TRANSPORTING OR TOWING:

ENGAGE TRANSPORT LOCKS AND SAFETY CHAINS:

- **RAISE MOWER** and **ENGAGE** center axle cylinder transport stops or pins.
- **RAISE WINGS** and **ENGAGE TRANSPORT LOCKS** or pins.
- **ATTACH** implement **SAFETY CHAIN** to tractor.
- **REMOVE** any cut material collected on mower deck.

DETERMINE STOPPING CHARACTERISTICS OF TRACTOR AND IMPLEMENT FOR TRANSPORTING OR TOWING:

BRAKING TESTS:

- **INSTALL** center axle cylinder transport stops or pins.
- Observe **STOPPING** distances increases with increased speeds.
- **DETERMINE** the maximum safe transport speed that does not exceed 20 mph.

DETERMINE MAXIMUM TURNING SPEED BEFORE OPERATING ON ROADS OR UNEVEN GROUND:

- **TEST** equipment in slowly increasing speed in turns to determine it can be operated at higher speeds.
- **USE REDUCED** turning speeds in sharp turns to avoid equipment turning over.

WHEN TOWING OR TRANSPORTING EQUIPMENT:

- Always **WEAR SEAT BELT** when operating or transporting mower.
- **USE** low speeds to avoid overturn with raised wings.
- **USE** low speeds and gradual steering on curves, hills, rough or uneven surfaces and on wet roads.
- **TURN ON** tractor **FLASHING WARNING LIGHTS**.
- **ALLOW** clearance for implement swing while turning.

KEEP all raised wings at 10 feet or greater distance from all power lines and overhead obstructions. PN TH01

SAFETY

HAZARDS WITH MAINTENANCE OF IMPLEMENT

Periodically inspect all moving parts, lubricate drivelines, and tighten all fasteners	Stop engine remove key before conducting maintenance	Block up implement before servicing Use large blocks on soft or wet soil	Engage cylinder transport locks	Inspect Blades for damage or cracks

⚠ WARNING AVOID SERIOUS INJURY OR DEATH FROM COMPONENT FAILURE BY KEEPING IMPLEMENT IN GOOD OPERATING CONDITION IN PERFORMING PROPER SERVICE, REPAIRS AND MAINTENANCE.

BEFORE PERFORMING SERVICE, REPAIRS AND MAINTENANCE ON THE IMPLEMENT:

- **STOP ENGINE AND PTO**, engage parking brake, lower implement, allow all moving parts to stop and remove key before dismounting from tractor.
- **PLACE** implement on ground or securely block up raised equipment. Use large blocks on soft or wet soil.
- **PUSH** and **PULL** Remote Hydraulic Cylinder lever to relieve hydraulic pressure.
- **DISCONNECT** implement driveline from tractor **PTO SHAFT**.

WEAR SAFETY GLASSES, PROTECTIVE GLOVES and follow **SAFETY PROCEDURES** when performing service, repairs and maintenance on the implement:

- Always **WEAR** protective **GLOVES** when handling blades, knives, cutting edges or worn component with sharp edges.
- Always **WEAR GLOVES** and **SAFETY GLASSES** when servicing hot components
- **AVOID CONTACT** with hot hydraulic oil tanks, pumps, motors, valves and hose connection surfaces.
- **SECURELY** support or **BLOCK UP** raised implement, framework and lifted components before working underneath equipment.
- **STOP** any implement movements and **SHUT-OFF TRACTOR** engine before doing any work procedures.
- **USE** ladder or raised stands to reach high equipment areas inaccessible from ground.
- **ENSURE** good footing by standing on solid flat surfaces when getting on implement to perform work.
- **FOLLOW** manufacturer's instructions in handling oils, solvents, cleansers, and other chemical agents.
- **DO NOT** change any factory-set hydraulic calibrations to avoid component or equipment failures.
- **DO NOT** modify or alter implement, functions or components.
- **DO NOT WELD** or repair rotating mower components. These may cause vibrations and component failures being thrown from mower.

PERFORM SERVICE, REPAIRS, LUBRICATION AND MAINTENANCE OUTLINED IN IMPLEMENT MAINTENANCE SECTION:

- **INSPECT** for loose fasteners, worn or broken parts, leaky or loose fittings, missing or broken cotter keys and washers on pins, and all moving parts for wear.
- **REPLACE** any worn or broken parts with authorized service parts.
- **LUBRICATE** unit as specified by lubrication schedule
- **NEVER** lubricate, adjust or remove material while it is running or in motion.
- **TORQUE** all bolts and nuts as specified.

BLADE INSPECTION:

- **REPLACE** bent, damage, cracked or broken blades immediately with new blades.
- **AVOID** blade failures and thrown broken blades. **DO NOT** straighten, weld, or weld hard-facing blades.

SAFETY SHIELDS, GUARDS AND SAFETY DEVICES INSPECTION:

- **KEEP** all Deflectors, Steel Guards, Gearbox Shields, and PTO integral shields, Bands, Side Skirts and Skid Shoes in place and in good condition.
- **REPLACE** any missing, broken or worn safety shields, guards and safety devices.
- **DISCONNECT** Pump solenoid valve or PTO driveline connection before servicing mower head.
- **FOLLOW INSTRUCTIONS** in maintenance section when replacing hydraulic cylinders to prevent component falling.

⚠ WARNING Operating, servicing and maintaining this equipment can expose you to chemicals including gasoline, diesel fuel, lubricants, petroleum products, engine exhaust, carbon monoxide, and phthalates, which are known to the State of California to cause cancer and birth defects or other reproductive harm. To minimize exposure, avoid breathing exhaust, do not idle the engine except as necessary, service your vehicle in a well-ventilated area and wear gloves or wash your hands frequently when servicing your vehicle. Battery posts, terminals and related accessories contain lead and lead compounds, chemicals known to the state of California to cause cancer, birth defects or other reproductive harm. For more information go to www.P65Warnings.ca.gov. This website, operated by California's Office of Environmental Health Hazard Assessment, provides information about these chemicals and how individuals may be exposed to them.

PN HMFM-02

SAFETY

SAFETY

PARTS INFORMATION

PARTS INFORMATION

Alamo Industrial mowers use balanced and matched system components for blade carriers, blades, cuttershafts, knives, knife hangers, rollers, drivetrain components, and bearings. These parts are made and tested to Alamo Industrial specifications. Non-genuine "will fit" parts do not consistently meet these specifications. The use of "will fit" parts may reduce mower performance, void mower warranties, and present a safety hazard. Use genuine Alamo Industrial mower parts for economy and safety. (SPAM-1)

SEE YOUR ALAMO DEALER

Operator's & Parts Manuals



www.algqr.com/apm

SAFETY

SAFETY

Decal Location

NOTE: Alamo Industrial supplies safety decals on this product to promote safe operation. Damage to the decals may occur while in shipping, use, or reconditioning. Alamo Industrial cares about the safety of its customers, operators, and bystanders, and will replace the safety decals on this product in the field, free of charge (Some shipping and handling charges may apply). Contact your Alamo Industrial dealer to order replacement decals.

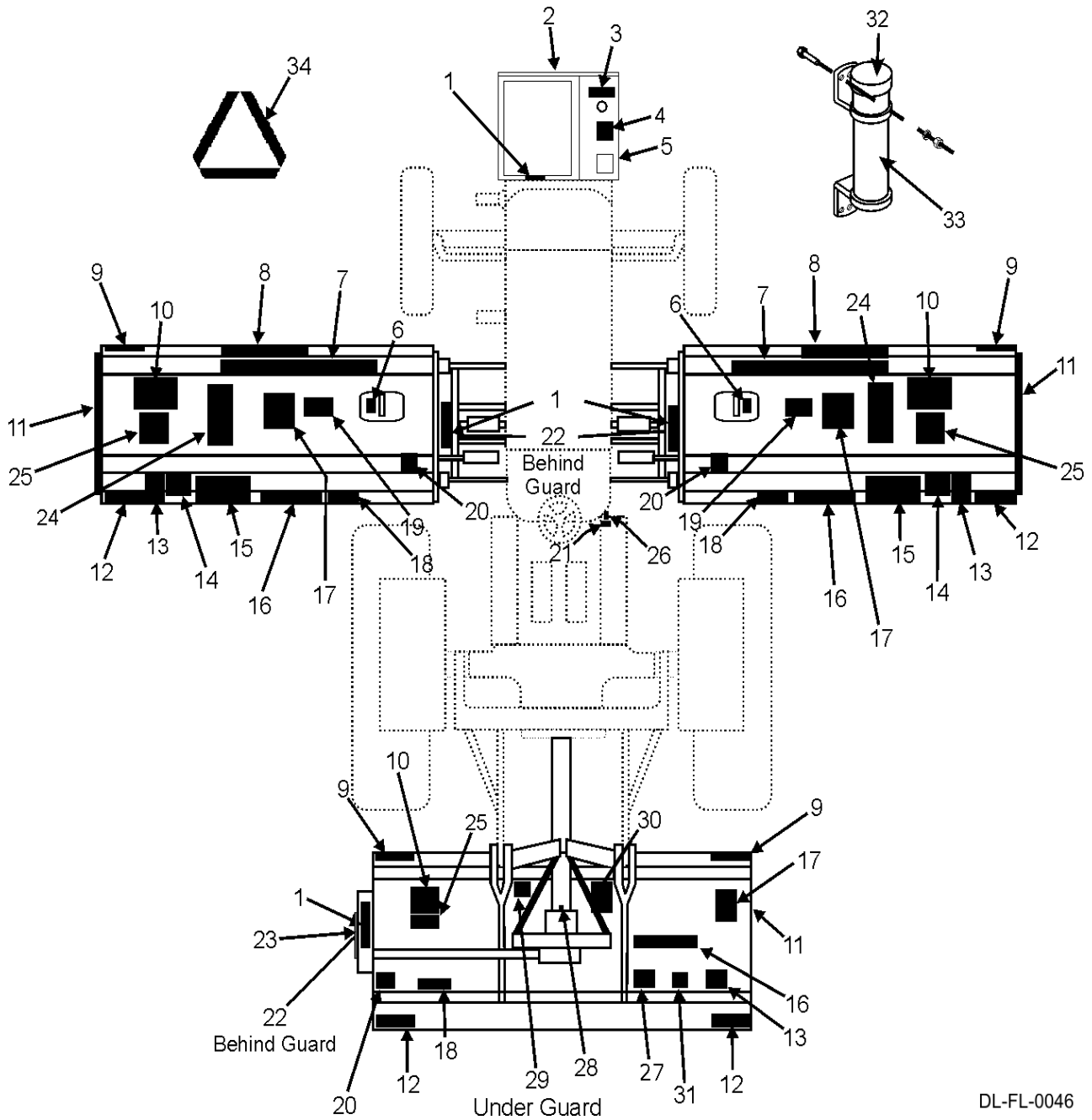

DL-FL-0046

SAFETY

SAFETY

ITEM	PART NO.	QTY	LEVEL	DESCRIPTION
1.	D641	4	WARNING	Pinch Point Hazard
2.	00757139	1	LOGO	Alamo Industrial
3.	D625	1	WARNING	Pressurized Tank
4.	D630	1	IMPORTANT	Service Hydraulic System
5.	D617	1	WARNING	Hydraulic Oil Leak
6.	D697	2	DANGER	Crushing Hazard
7.	02979544	2	LOGO	Alamo Industrial 6-1/4"x43-1/2"
8.	001660	2	LOGO	Interstater
9.	1458393	4	REFLECTR	Yellow Reflector Decal
10.	D687	3	DANGER	Multi Hazard
11.	02979546	3	LOGO	Alamo Industrial 2"x13-9/16"
12.	1458392	4	REFLECTR	Red Reflector Decal
13.	002023	3	INSTRUCT	Height Adjustment
14.	D701	2	INSTRUCT	Wing Lube Chart
15.	D682	2	DANGER	Entanglement Hazard
16.	001651	3	LOGO	Alamo Industrial 4-5/8"x16-5/8"
17.	D816	3	WARNING	Use Alamo Industrial Genuine Parts
18.	D626	3	DANGER	Thrown Object Hazard
19.	D698	2	DANGER	Wing Falling
20.	000108	3	INSTRUCT	Operating Instructions
21.	D685	1	WARNING	Avoid Inadvertent Unfolding
22.	D646	3	DANGER	Guard Missing
23.	001650	1	LOGO	Alamo Industrial
24.	D699	2	DANGER	Multi-Hazard Fire
25.	D831	3	DANGER	Multi-Hazard Language
26.	001412	1	INSTRUCT	Control Valve
27.	D708	1	WARNING	Fire Hazard Clear Debris
28.	D726	1	INSTRUCT	Grease Fitting
29.	D546	1	DANGER	Guard Missing
30.	D547	1	DANGER	Driveline Hazard
31.	D700	1	INSTRUCT	Lube Chart Rear Flail
32.	00776031	1	-----	Canister (Operator's Manual)
33.	803213C	1	-----	Operators Manual
34.	03200347	1	REFLECT	SMV

SAFETY

Decal Description

SAFETY

⚠ WARNING	
PINCH POINT HAZARD	
TO AVOID SERIOUS INJURY: <ul style="list-style-type: none">• DO NOT OPERATE with Belt Shield removed.	D641

⚠ WARNING	
PRESSURIZED TANK OIL FILLER CAP IS PRESSURE RELIEF CAP	
TO AVOID SERIOUS INJURY AND DEATH FROM HOT OIL: <ul style="list-style-type: none">• STAY AWAY from hot oil that may spray out of tank.• ALLOW oil to cool down BEFORE removing cap .• SLOWLY remove cap to relieve pressure BEFORE removing completely.	D625

⚠ DANGER	
	
Crushing Hazard	
Transport latch RAISE AND SECURELY position Wing onto Transport Latch before transporting mower on roadways or working under wing.	
D697	

SAFETY

SAFETY

⚠ WARNING



TO AVOID SERIOUS INJURY OR DEATH FROM HIGH PRESSURE HYDRAULIC OIL LEAKS PENETRATING SKIN:

- DO NOT OPERATE equipment with oil or fuel leaks.
- KEEP all hydraulic hoses, lines and connections in good condition and tight before applying system pressure.
- Relieve hydraulic pressure before disconnecting lines or working on the system.
- REMOVE and replace hose if you suspect it leaks. Have dealer test it for leaks.

HIGH PRESSURE FLUID LEAKS CAN BE INVISIBLE. WHEN CHECKING FOR HYDRAULIC LEAKS AND WORKING AROUND HYDRAULIC SYSTEMS:

- DO NOT use hands to check for leaks.
- ALWAYS WEAR safety glasses and impenetrable gloves.
- USE paper or cardboard to search for leaks.
- KEEP hands and body AWAY from pin holes and nozzles ejecting hydraulic fluid.
- Hydraulic fluid may cause gangrene if not surgically removed immediately by a doctor familiar with this form of injury.

D617

⚠ DANGER



D646

**GUARD MISSING
DO NOT OPERATE**

SAFETY

SAFETY

! DANGER

D687_1

THROWN OBJECTS HAZARD

Mower can throw objects up to 300 feet. TO AVOID SERIOUS INJURY OR DEATH to operator or bystanders:

- STOP mowing if bystanders or traffic come within 300 feet.
- DO NOT OPERATE with thrown object shielding removed.
- KEEP thrown object shielding in place and in good condition during operation. Thrown Objects shielding is subject to wear.
- REPAIR OR REPLACE shielding if damaged, broken or missing. See Operator's Manual for all Shields and Guards.
- INSPECT area for potential mower thrown object hazards before mowing.
- Remove and AVOID objects such as wire, cable, metal objects and all other foreign material.
- DO NOT ALLOW blades to contact solid objects like wire, rocks, posts, curbs or guard rails.
- DO NOT OPERATE in transport position or with wings off ground.

! DANGER



Run Over Hazard - Injury or Death

TO AVOID SERIOUS INJURY OR DEATH:

- ALWAYS BUCKLE UP seat belt.
- ONLY START Tractor while seated in the operator's seat.
- STOP ENGINE and PTO, engage parking brake, lower implement, allow all moving parts to stop and remove key before dismounting from tractor.
- KNOW HOW to stop tractor and equipment quickly for an emergency.
- DO NOT MOUNT or DISMOUNT Tractor in motion.
- NEVER ALLOW riders on tractor or implement.
- NEVER ALLOW children to operate or ride on tractor or implement.
- KEEP BYSTANDERS CLEAR of area before moving tractor or implement.
- KEEP ALERT and AVOID hitting stumps, holes, ruts, and uneven terrain.
- AVOID tree limbs, brush and other overhanging objects that can strike and throw the operator from seat.

SAFETY

SAFETY

⚠ DANGER	
ENTANGLEMENT HAZARD	
<p>TO AVOID SERIOUS INJURY OR DEATH:</p> <ul style="list-style-type: none"> • DO NOT operate without guards in place and in good condition. PTO and gearbox guarding are SUBJECT TO WEAR. • STAY AWAY and KEEP hands, feet and body AWAY from rotating blades, drivelines and parts that continue to move after power shut-off. WAIT until all moving elements have stopped. • ALWAYS REPLACE GUARDS that have been removed for service or maintenance. • STOP, LOOK and LISTEN for rotating motion before approaching implement. • DO NOT STEP ON drivelines or guards. 	   <p style="font-size: small;">Tractor PTO Guard (Cubierta del PTO) Implement PTO Guard (Cubierta del PTO) Shields (Cubiertas)</p>
D687_2	

⚠ DANGER	
Crushing Hazard - Injury or Death	
<p>TO AVOID SERIOUS INJURY OR DEATH:</p> <ul style="list-style-type: none"> • USE tractor equipped with Rollover Protective Structure ("ROPS") including roll bar and seat belt. Keep roll bar in raised position. • STAND CLEAR when removing transport latch, lowering or raising wings. • CLEAR AREA of bystanders before lowering implement wings. • IMPLEMENT CAN FALL from hydraulic failure or accidental operation of controls. • BLOCK UP and securely support equipment before putting hands, feet or body under raised equipment or lifted components. 	  
D687_3	

⚠ DANGER			
			
D687_5	www.algqr.com/afe		
<p>TO AVOID SERIOUS INJURY OR DEATH:</p> <ul style="list-style-type: none"> • READ AND UNDERSTAND the provided Operator's Manuals, safety signs and information decals for tractor and implement before operating equipment. • CONTACT DEALER immediately if you do not have manuals. • CONTACT DEALER to explain any instructions not fully understood. • ALWAYS WEAR safety glasses. • WEAR hard hat, safety shoes and gloves for protection when operating equipment. 			D687

SAFETY

SAFETY

! DANGER

Entanglement Hazard



Mower head will start running when lowered if Mower ON/OFF Switch is ON.

TO AVOID SERIOUS INJURY OR DEATH:

- MAKE CERTAIN the ON/OFF SWITCH is OFF before lowering mower head.
- CLEAR AREA of bystanders before lowering mower head.

Mower head automatically shuts OFF when raised above 45°.

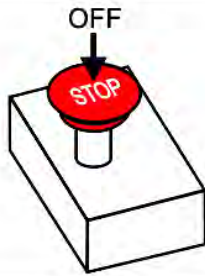
D682



! DANGER

THROWN OBJECT HAZARD

TO AVOID SERIOUS INJURY OR DEATH:

DO NOT OPERATE if Thrown Object Shielding is damaged or missing.

- Maintain Rubber Deflectors in good condition.
- Inspect Rubber Deflectors frequently.

MAINTAIN Thrown Object Shielding

↙ HERE ↓



D626



Rubber Deflector



Chain Guards



SAFETY

SAFETY

⚠ WARNING

Non-genuine parts can fail catastrophically.
TO AVOID SERIOUS INJURY OR DEATH:

- ONLY use genuine ALAMO INDUSTRIAL replacement parts.
- Non-genuine parts can fail creating hazardous conditions for operator and bystanders.

Contact local dealer or ALAMO INDUSTRIAL about repair parts at:
1502 E. Walnut, Seguin, TX 78155.
Customer Service: 800-882-5762.
Email: support@alamo-industrial.com

www.algqr.com/apm



⚠ WARNING

Cancer and Reproductive Harm
www.P65Warnings.ca.gov

IMPORTANT

BE AWARE **BE TRAINED**
BE ALERT **BEFORE OPERATING THIS MOWER**
BE ALIVE



To prevent serious injury to yourself and/or bystanders, be trained in Safe Mowing Practices. Alamo Group Companies as well as AEM and FEMA provide training material that is critical for your Safety and the Safety of others when operating this equipment. Make these Safety Procedures an important part of every workday. Read and understand the Operator's Manual.

Do not let untrained individuals operate this equipment. Contact your Dealer, AEM (www.aem.org), FEMA (314-878-2304, www.FarmEquip.org), or Alamo Group (www.Alamo-Group.com) for information on training material or courses that provide training in Safer Operating Practices for Mowers.

D816

⚠ WARNING

TO AVOID EQUIPMENT AND GRASS FIRES:

- CLEAR AWAY grass or debris from slip clutches, gearboxes, drivelines and decks.

TO AVOID FIRE IGNITION:

- DO NOT ALLOW BLADES TO CONTACT rocks, metal or solid objects.



D708

SAFETY

SAFETY

! DANGER



Crushing Hazard - Injury or Death

TO AVOID SERIOUS INJURY OR DEATH:

- **STAND CLEAR** when removing transport latch, lowering or raising wings.
- **CLEAR AREA** of bystanders before lowering implement wings.
- **IMPLEMENT CAN FALL** from hydraulic failure or accidental operation of controls.
- **BLOCK UP** and securely support equipment before putting hands, feet or body under raised equipment or lifted components.
- **SECURELY ENGAGE** transport latch before transportation or working under wing.
- **FILL CYLINDERS** with oil before attempting to lower implement wings.
- **DO NOT OPERATE** in transport position or with wings off ground.

D698

! WARNING



To Avoid Inadvertent Unfolding and Serious Injury during Transportation:

- Transport with lever in neutral position.

D685

! DANGER



D546

GUARD MISSING DO NOT OPERATE

D546 B

SAFETY

SAFETY

⚠ WARNING		
		
TO AVOID SERIOUS INJURY AND DEATH DURING TRANSPORTATION:		
<ul style="list-style-type: none">• ALWAYS BUCKLE UP seat belt.• PLACE wing securely in Transport latch and turn off master switch.• CHECK SMV sign, reflectors and warning lights for visibility behind unit.• TURN ON tractor flashing warning lights.		
TO AVOID LOSS OF TRANSPORTATION CONTROL:		
<ul style="list-style-type: none">• DO NOT travel at speeds over 20 mph.• REDUCE SPEED on inclines, in turns and in poor weather conditions.		
⚠ WARNING		
TO AVOID SERIOUS INJURY AND DEATH DURING OPERATION:		
<ul style="list-style-type: none">• DO NOT lift implement while on steep slopes.• KEEP AWAY from soft ditch banks and holes.• ALWAYS MAINTAIN 20% of tractor weight on front wheels.• DO NOT start or accelerate suddenly.• KEEP mower AT LEAST 10 FEET AWAY from electric lines and pipe lines.		
⚠ WARNING		
TO AVOID EQUIPMENT AND GRASS FIRES:		
<ul style="list-style-type: none">• CLEAR AWAY grass or debris from hydraulic lines, circuits and decks.		
TO AVOID FIRE IGNITION:		
<ul style="list-style-type: none">• DO NOT ALLOW BLADES TO CONTACT rocks, metal or solid objects.• DO NOT ALLOW OIL TO SPRAY on hot equipment or components. D699_3		

SAFETY

SAFETY

 PELIGRO	 DANGER
Si no puede leer inglés: antes de poner en funcionamiento este equipo, solicite que alguien le traduzca los mensajes de seguridad o vaya al sitio web para consultar los mensajes de seguridad y las etiquetas ya traducidos.	Si vous ne savez pas lire le français: avant d'utiliser l'équipement, demandez à une personne de vous traduire les messages de sécurité ou allez sur le site Internet pour voir la traduction des autocollants et des messages de sécurité.
El Manual del Operador Seguridad vídeo   www.algqr.com/afs	Manuel de l'Opérateur   www.algqr.com/aff

 PERIGO	 GEFAHR
Caso você não leia inglês: antes de operar o equipamento, peça para alguém traduzir as mensagens de segurança ou visite a web e obtenha tais mensagens ou os decalques traduzidos.	Falls Sie Deutsch nicht lesen können: Lassen Sie sich, bevor Sie das Gerät in Betrieb nehmen, die Sicherheitshinweise von einer geeigneten Person in Ihre Sprache übersetzen. Oder suchen Sie auf unserer Website nach Übersetzungen von Schilderaufschriften und Sicherheitshinweisen.
Manual do Operador   www.algqr.com/afp	Benutzerhandbuch   D831 www.algqr.com/afg

SAFETY

SAFETY

⚠ DANGER

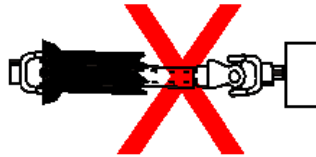

TO AVOID SERIOUS INJURY OR DEATH FROM DRIVELINE CONTACT, DRIVELINE SEPARATION OR PTO STUB SHAFT FAILURE:

- STOP, LOOK and LISTEN for rotating motion before approaching implement.
- STAY AWAY and KEEP hands, feet and body AWAY from rotating parts until all moving elements have stopped.
- ALWAYS shut off PTO before dismounting.
- DO NOT operate if PTO shields are damaged or missing.
- PUSH AND PULL on yoke until collar clicks and locks yoke in place.
- CHECK driveline guards for free rotation and sufficient overlap to avoid unshielded areas.
- DO NOT USE PTO ADAPTER

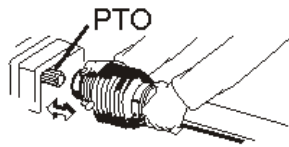

⚠ WARNING

OPERATE THIS MACHINE AT

540 RPM

TRACTOR PTO SPEED ONLY.

Overspeeding PTO may cause component failure resulting in bodily injury.

TRACTOR PTO ROTATION: CLOCKWISE

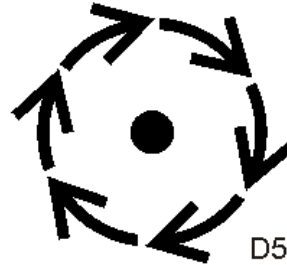

D547

D547 B

SAFETY

Federal Laws and Regulations

This section is intended to explain in broad terms the concept and effect of federal laws and regulations concerning employer and employee equipment operators. This section is not intended as a legal interpretation of the law and should not be considered as such.

Employer-Employee Operator Regulations

U.S. Public Law 91-596 (The Williams-Steiger Occupational and Health Act of 1970) OSHA

This Act Seeks:

“...to assure so far as possible every working man and woman in the nation safe and healthful working conditions and to preserve our human resources...”

DUTIES

Sec. 5 (a) Each employer-

- (1) shall furnish to each of his employees employment and a place of employment which are free from recognized hazards that are causing or are likely to cause death or serious physical harm to his employees;
- (2) shall comply with occupational safety and health standards promulgated under this Act.
- (b) Each employee shall comply with occupational safety and health standards and all rules, regulations and orders issued pursuant to this Act which are applicable to his own actions and conduct.

OSHA Training Requirements

Title 29, Code of Federal Regulations Part 1928.57(a)(6). www.osha.gov

Operator instructions. At the time of initial assignment and at least annually thereafter, the employer shall instruct every employee who operates an agricultural tractor and implements in the safe operating practices and servicing of equipment with which they are or will be involved, and of any other practices dictated by the work environment.

Keep all guards in place when the machine is in operation;

Permit no riders on equipment

Stop engine, disconnect the power source, and wait for all machine movement to stop before servicing, adjusting, cleaning or unclogging the equipment, except where the machine must be running to be properly serviced or maintained, in which case the employer shall instruct employees as to all steps and procedures which are necessary to safely service or maintain the equipment.

Make sure everyone is clear of machinery before starting the engine, engaging power, or operating the machine.

Employer Responsibilities:

To ensure employee safety during Tractor and Implement operation, it is the employer's responsibility to:

1. Train the employee in the proper and safe operation of the Tractor and Implement.
2. Require that the employee read and fully understand the Tractor and Implement Operator's manual.
3. Permit only qualified and properly trained employees to operate the Tractor and Implement.
4. Maintain the Tractor and Implement in a safe operational condition and maintain all shields and guards on the equipment.
5. Ensure the Tractor is equipped with a functional ROPS and seat belt and require that the employee operator securely fasten the safety belt and operate with the ROPS in the raised position at all times.
6. Forbid the employee operator to carry additional riders on the Tractor or Implement.
7. Provide the required tools to maintain the Tractor and Implement in a good safe working condition and provide the necessary support devices to secure the equipment safely while performing repairs and service.
8. Require that the employee operator stop operation if bystanders or passersby come within 300 feet.

Child Labor Under 16 Years of Age

Some regulations specify that no one under the age of 16 may operate power machinery. It is your responsibility to know what these regulations are in your own area or situation. (Refer to U.S. Dept. of Labor, Employment Standard Administration, Wage & Home Division, Child Labor Bulletin #102.)

INDUSTRIAL/
AGRICULTURAL MOWER



www.aem.org

SAFETY MANUAL

FOR OPERATING AND MAINTENANCE PERSONNEL

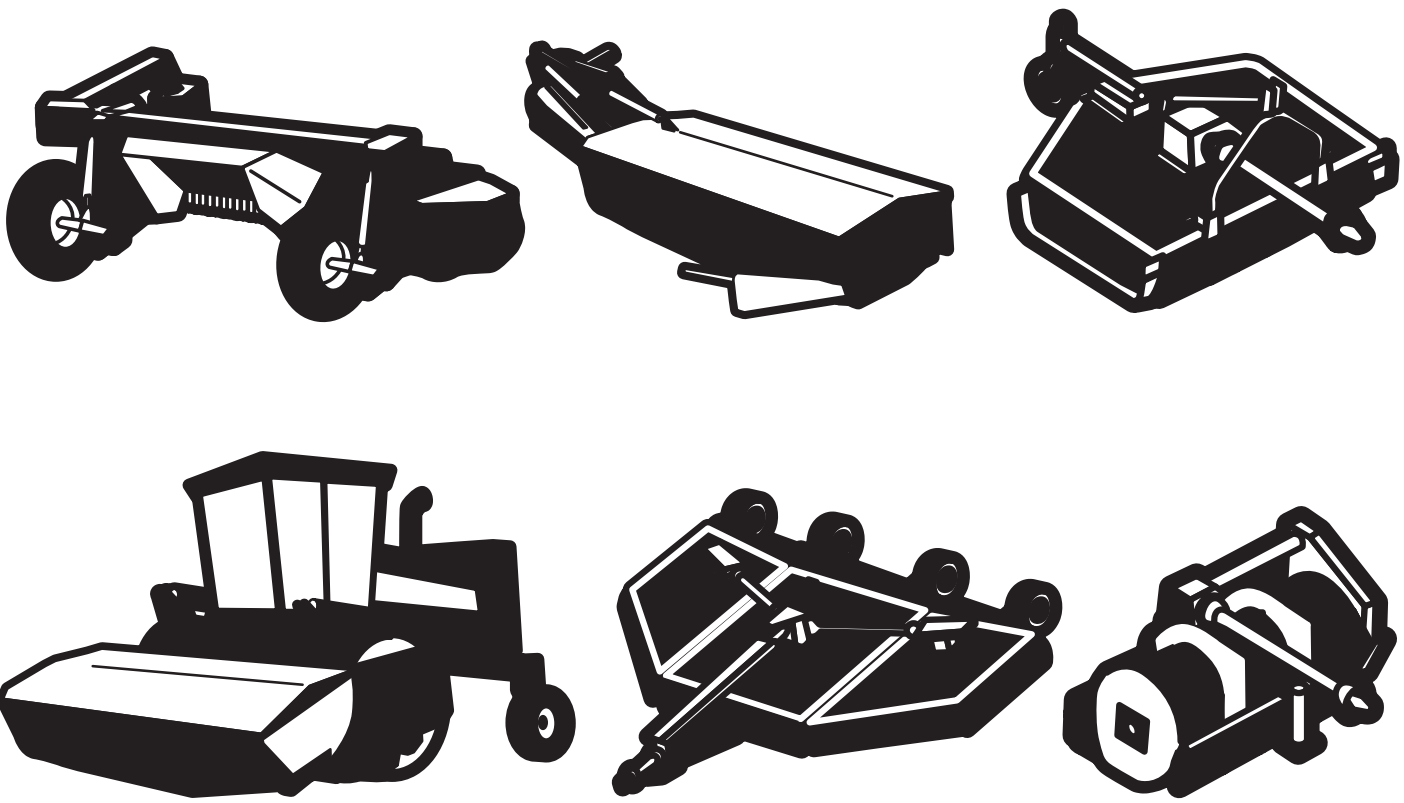

Contents

Acknowledgment	2
Foreword	2
Safety Alerts	3
A Word To The User/Operator	3
The Industrial/Agricultural Mower	4
Follow A Safety Program	5
Prepare For Safe Operation	9
Start Safely	13
Operate Safely	13
Park Safely	18
Shut Down Safely	18
Perform Maintenance Safely	19
Final Word To The User	26

Acknowledgment

We wish to acknowledge the contributions of the members of AEM's Industrial/Agricultural Mower Manufacturers Council to the preparation of this Safety Manual.

NOTICE OF COPYRIGHT PROTECTION

Copyright, 2010, by the Association of Equipment Manufacturers. All rights reserved. This work may not be reproduced or disseminated in whole or in part by any means without the prior written permission of the Association of Equipment Manufacturers.

Copyright 2010© AEM (Association of Equipment Manufacturers)
Revised 01/03, 09/10

Foreword

This safety manual is intended to point out some of the basic safety situations that may be encountered during the normal operation and maintenance of your machine and to instruct you in safety practices for dealing with these conditions. This manual is **NOT** a substitute for the mower manufacturer's operator's manual(s).

Additional precautions may be necessary, or some instructions may not apply, depending on equipment, attachments and conditions at the worksite or in the service area. The manufacturer has no direct control over equipment application, operation, inspection or maintenance. Therefore, it is **YOUR** responsibility to use good safety practices in these areas.

The information provided in this manual supplements the specific information about your machine that is contained in the manufacturer's operator's manual(s). Other information that may affect the safe operation of your machine may be contained on safety signs or in insurance requirements, employer's safety and training programs, safety codes, local, state/provincial and federal laws, rules and regulations.

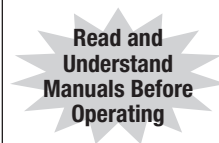
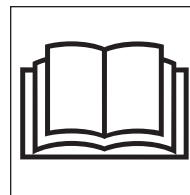

IMPORTANT! Before you operate the mower, make sure you have the manufacturer's operator's manual(s) for this machine and all attachments. If the manufacturer's manuals are missing, obtain replacement manuals from your employer, equipment dealer or directly from the manufacturer. Keep this safety manual and the manufacturer's manuals with the machine at all times. Read and understand all manuals.

The AEM Mower Safety Practices video is available to train and reinforce good safety practices. Operators are encouraged to periodically view the safety video.

Safety Alerts

Symbol

This Safety Alert Symbol means: “**ATTENTION! STAY ALERT! YOUR SAFETY IS INVOLVED!**”

The Safety Alert Symbol identifies important safety messages on equipment, safety signs, in manuals or elsewhere. When you see this symbol, be alert to the possibility of death or personal injury. Follow instructions in the safety message.







Reasons Safety is Important:

- Accidents disable and kill.
- Accidents cost.
- Accidents can be avoided.

Signal Words

Signal words are distinctive words that will typically be found on safety signs on the mower and other worksite equipment. These words may also be found in this manual and the manufacturer’s manuals. These words are intended to alert the operator to a hazard and the degree of severity of the hazard.

-  **DANGER** indicates a hazardous situation which, if not avoided, will result in death or serious injury.
-  **WARNING** indicates a hazardous situation which, if not avoided, could result in death or serious injury.
-  **CAUTION** indicates a hazardous situation which, if not avoided, could result in minor or moderate injury.
-  **NOTICE** indicates a property damage message.

A Word To The User/Operator

It is **YOUR** responsibility to read and understand the safety manual and the manufacturer’s manuals before operating this machine. This safety manual takes you step by step through your working day.

Hazard Recognition and Accident Prevention depend upon you being alert, careful and properly trained in the operation, transport, maintenance and storage of this equipment.

Graphics have been provided to help you understand the text.

Remember that **YOU** are the key to safety. Good safety practices not only protect you but also protect the people around you. Study and understand this manual and the manufacturer’s manuals for your specific machine. Make them a working part of your safety program. Keep in mind that this safety manual is written for industrial/agricultural mowers.

Contact the manufacturer of your equipment to answer any questions about safe operation that remain after studying the manufacturer’s operator’s manual(s) and this safety manual.

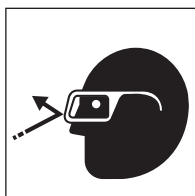

Practice all other usual and customary safe working precautions and above all:
REMEMBER – SAFETY IS UP TO YOU!
YOU CAN PREVENT SERIOUS INJURY OR DEATH CAUSED BY UNSAFE WORK PRACTICES!

The Industrial/Agricultural Mower

Industrial/Agricultural Mower Types

Mowers are used for pasture clipping, crop residue shredding, heavy brush cutting, waterways, right-of-ways, roadside or highway mowing. Also, these mowers are used for cutting grass and other growth in public areas such as parks and cemeteries.

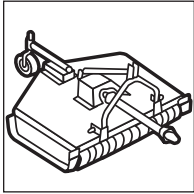

Rotary

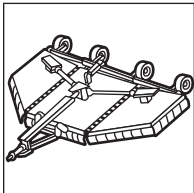

Folding Wing Rotary

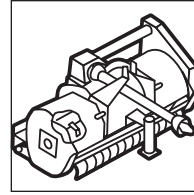

Flail

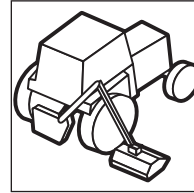

Boom

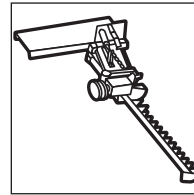

Sickle Bar

The Industrial/Agricultural Mower

Agricultural Disc Mower Types

Disc mowers are designed and equipped to cut hay crops at higher field speed.

Disc mower/conditioners mow and condition crops.

Self-propelled windrowers mow and form conditioned hay into windrows.

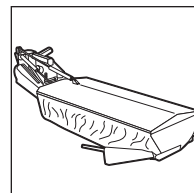

Disc Mower

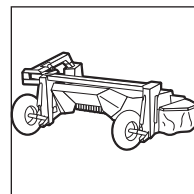

Disc Mower Conditioner

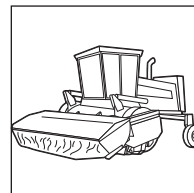

Self-propelled Windrower

Follow A Safety Program

Protect Yourself

Wear personal protective clothing and Personal Protective Equipment (PPE) issued to you or called for by job conditions. You must **ALWAYS** wear safety glasses with side shields.

You may also need:

- Hard hat
- Safety shoes
- Safety goggles or face shield
- Heavy gloves
- Hearing protection
- Reflective clothing
- Wet weather gear
- Respirator or filter mask

Wear whatever is needed—don't take chances.

WARNING! Prevent death or serious injury from entanglement. **Do not wear loose clothing or accessories. Tie up long hair. Stay away from all rotating components when the engine is running.** Contact, wrapping or entanglement with rotating or moving parts could result in death or serious injury.

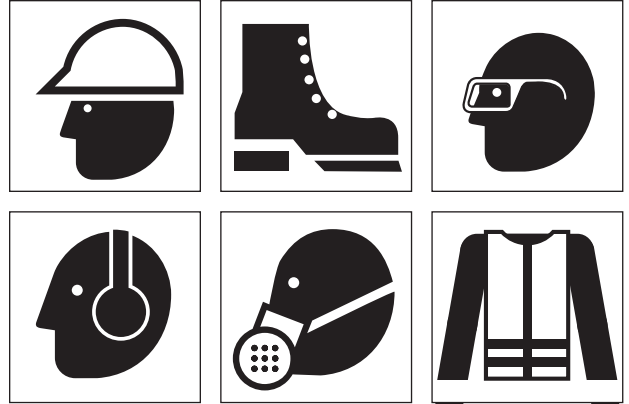

Avoid Entanglement

Follow A Safety Program

- Read, understand and follow the manufacturer's written instructions found in the operator's manual(s) and safety signs on mower and tractor.
- Have operational training with mower and tractor.
- Take advantage of training programs offered in your area.
- Ask your equipment dealer or supervisor to explain things you do not understand.
- Explain the written instructions in the operator's manual(s) and safety signs to those users or operators who cannot read.
- Inspect the mower and tractor daily before operating. Ensure all guards are in place and the equipment is operating properly.
- Never smoke while operating. Never fill the fuel tank with the engine running or near an open flame.
- Make sure you have adequate visibility and sufficient lighting.
- Know the pinch points and rotating parts. Awareness on your part can prevent accidents.
- Never attempt to operate the controls except from the operator's seat. Improperly controlled functions could produce unexpected machine movement and result in serious injury or death.

- Shut down the mower and tractor before dismounting. (See page 18, **Proper Equipment Shut Down Practices.**)

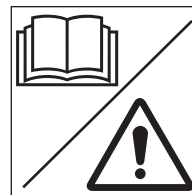

Read, Understand and Follow Manuals and Safety Signs



Avoid Rotating Parts

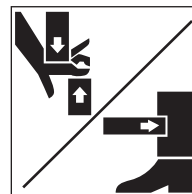

Know and Avoid Pinch Points

Follow A Safety Program

Avoid Injury From Raised Equipment

Avoid possible crushing injury from falling mower or other raised equipment.



**Avoid Crushing –
Block Up or
Securely Support
Mower**

Before working near or under raised mower or equipment parts:

- Securely support or block up raised mower or equipment parts according to the operator's manual.
- Securely support, block up or lock up wings with approved locking devices or lower mower or equipment parts to the ground.
- Use transport locks when transporting mower on public roads.

Avoid Injury From High Pressure Fluid

Avoid fluid injection injury due to high pressure fluid leaks.



**High Pressure
Fluid Can Inject
into the Body**

If any fluid is injected into the skin, it must be removed within a few hours by a doctor familiar with this type of injury.

Fluid leaks under pressure may not be visible. When checking for leaks or working around pressurized systems:

- Read manufacturer's operator's manual(s) for recommended safety practices.
- Wear a face shield or safety goggles for eye protection.
- Use a piece of cardboard or wood to check for leaks; **DO NOT use your hands.**
- Relieve system pressure before disconnecting lines.
- Check for and repair damaged or leaking lines, pipes and hoses.
- Check for and tighten loose connections.
- Purge air from system before operating.

Follow A Safety Program

Avoid Injury From Fire And Explosion

Set the parking brake, shut the mower and tractor engine down and remove the key while filling the fuel tank. Use extra caution when fueling a hot engine. Never smoke while fueling. Avoid sparks by grounding the fuel nozzle against the filler neck.

The fumes in an empty fuel tank are explosive. Never weld or cut on fuel lines, tanks or containers.

Remove all trash or mowing debris from the machine daily or as needed. Keep debris away from engine, exhaust, slip clutches and other heat sources. Use spark arrestors, as appropriate, on the engine exhaust system. Make sure oily rags or other flammable material are not stored on the machine.

Check for fuel, oil or hydraulic fluid leaks. Repair the leaks and clean the machine before you operate it.

Ether/cold start fluid is flammable. Do not smoke when using ether/cold start fluid. Always follow the instructions on the can and in the manufacturer's operator's manual(s) for your mower. Do not use ether/cold start fluid if the engine is equipped with a glow plug or other type of preheater.

Always use a nonflammable solvent when you clean parts. Do not use gasoline, diesel fuel or other flammable fluids.

Store all flammable fluids and materials away from your machine and work area.

Know where fire extinguishers are kept—how they operate—and what type of fire they are for. Check readiness of fire extinguishers according to manufacturer's instructions. Make sure each tractor is equipped with a fire extinguisher.



**No Smoking
and No Open
Flames**

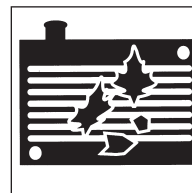

**Remove
Debris Daily or
As Needed**

Follow A Safety Program

Be Alert!

Know where to get assistance. Know how to use a first aid kit and fire extinguisher/fire suppression system.

Be Aware!

Take advantage of training programs offered.

Be Careful!

Human error is caused by many factors: carelessness, fatigue, overload, preoccupation, unfamiliarity of operator with the machine, drugs, and alcohol to name a few. Damage to the tractor or mower can be fixed in a short period of time, but injury, or death, has a lasting effect.

For your safety and the safety of others, encourage your fellow workers to act safely.



For Safe Operation

You must be a qualified and authorized operator for proper operation of your machine. You must clearly understand the written instructions supplied by the manufacturer, be trained—including actual operation of the mower—and know the safety rules and regulations for the worksite. It is a good safety practice to point out and explain safety signs and practices and ensure others understand the importance of following these instructions.

WARNING! Drugs and alcohol affect an operator's alertness and coordination and the operator's ability to safely operate the equipment. **Never use drugs or alcohol while operating the mowing equipment. Never knowingly allow anyone to operate this machine when their alertness or coordination is impaired.** An operator taking prescription or over-the-counter medication must consult a medical professional regarding any side effects of the medication that would hinder their ability to safely operate this equipment.

Follow A Safety Program

Know The Rules

Most employers have rules governing operation and maintenance of equipment. Before you start work at a new location, check with your supervisor or the safety coordinator. Ask about the rules you will be expected to obey.

The Occupational Safety and Health Administration (OSHA) enforces federal laws within the United States that apply to safe operation, application and maintenance of equipment on a worksite. It is the employer's responsibility to comply with these laws. An OSHA representative may periodically inspect a worksite to see that these laws are being followed.

There may also be local or state/provincial laws or international regulations that apply to this equipment and its use, along with specific worksite or employer rules. It is important that you know and comply with all applicable laws and rules, including those requiring operator training and certification.

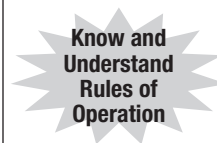

These are some of the rules you must work by:

- A ROPS and seat belt-equipped tractor is a federal government (OSHA) requirement for operator protection during mowing operations. An enclosed cab provides additional operator protection from thrown objects. Check your mower operator's manual to see if a tractor cab is also required.
- Wear and check that others are wearing proper clothing and personal protective equipment.
- Inspect your machine and attachments before each use as specified by the manufacturer and your employer.
- Know the limitations and operating characteristics of your mowing equipment. Do not misuse it.
- Have all provided shields and guards properly installed before operating the machine.
- Never modify or remove any part of the machine (except for service—then make sure it is replaced).

Follow A Safety Program

Some Rules You Must Work By (continued)

- Only qualified and authorized individuals may operate this equipment.
- **Never allow children to play on, ride on or operate** the equipment. Children **are not** qualified to operate this equipment.
- **Do not allow any riders.**
- Use three-point contact (handholds and steps) and face the equipment when mounting or dismounting.
- Keep bystanders 300 ft (92 m) from the mowing operation.
- Know the worksite before you use the mower. Be aware of possible terrain hazards that you may encounter. Remove or mark obstacles and debris that could damage or be thrown by the mower.
- Only use attachments and parts that are approved by the mower manufacturer.
- Make sure all attachments are lowered, set the parking brake, shut off the engine and cycle the control levers. Remove the key before leaving the tractor. (See page 18, **Proper Equipment Shut Down Practices.**)
- When transporting the mower on a trailer, follow the manufacturer's detailed instructions for loading, tying down and unloading the mower.



Keep Children Away from Equipment

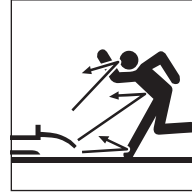

Keep Bystanders Away



No Riders

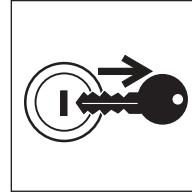

Shut Down Unattended Equipment

Follow A Safety Program

Know The Equipment

Read and understand the DANGER, WARNING, CAUTION and NOTICE safety signs and other informational signs on the tractor and mower and in the manufacturer's operator's manual. Ask your supervisor or mower dealer to explain any information you do not understand. Failure to obey safety instructions could result in death or serious injury.

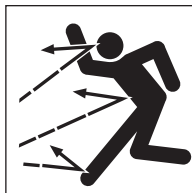

Read and Understand All Safety Signs

Make sure all the manufacturer's protective structures, guards, shields, screens and panels are in good repair, in place and securely fastened. Damaged, missing or weakened safety components can create a hazardous situation for you as the operator. **Never** remove or modify any safety components including thrown object shielding on a mower.

Know the following about your tractor and mower:

- Function, purpose and use of all controls.
- Correct operation speeds.
- Slope and uneven terrain capabilities and proper operation.
- Braking and steering characteristics.
- Turning radius and clearances.
- How to quickly stop equipment in an emergency.

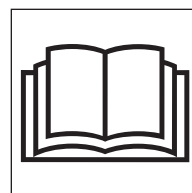

Read and Understand Manuals Before Operating

Prepare For Safe Operation

Check The Mower And Tractor Equipment

Before beginning your work day inspect the machine and have all systems in good operational condition.

WARNING! Prevent possible crushing injury from falling equipment. Hydraulic system or part failure could cause unsupported equipment to fall. **Do not go under raised equipment unless it is properly supported according to the operator's manual.**

- Perform daily and periodic service procedures as instructed by the equipment manufacturer.
- Check for loose, broken, missing or damaged tractor and mower parts. Repair or replace these parts.
- Check for proper tractor and mower attachments.
- Check for proper tractor and mower PTO rpm rating match.
- Check mower blade(s) condition. Replace severely worn, bent, gouged or nicked blades including the blade bolts and fasteners. Never straighten or weld on blades.
- Ensure thrown object shielding is properly installed and in good condition. Repair or replace if damaged or missing.

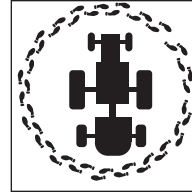

Walk-Around Inspection

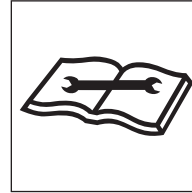

Maintain Machine

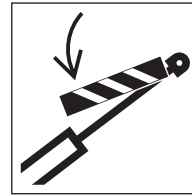

Read Manual – Block Up or Securely Support Mower

Prepare For Safe Operation

- Check that all guards and shields are in place and that all equipment is in good operating condition. This includes PTO driveline, gearbox and implement guards and shields that are used for operator protection.
- Check for properly latched driveline yoke-end locking devices.
- Check for damaged or leaky tractor and mower hydraulic systems. Repair or adjust as needed.

WARNING! Hydraulic fluid under pressure can penetrate the skin or eyes and cause serious injury, blindness or death. Fluid leaks under pressure may not be visible.

Use a piece of cardboard or wood to find leaks, not your hand. Wear eye protection. If fluid is injected into the skin, it must be removed within a few hours by medical personnel familiar with this type of injury.

- Keep the operator platform surface clean and free of grease, oil, dirt, snow or ice. Steps and handholds must be clean and functional.
- Ensure work lights are kept clean (if equipped). Check that all lights work properly.
- Ensure the slow moving vehicle (SMV) sign, reflectors and warning lights are in good condition and can be clearly seen.

- Ensure all tools or loose objects are removed or securely fastened while operating the machine.
- Check all safety signs for clarity. Replace damaged signs.



Check for Missing/ Damaged Guards and Shields



Check for Leaks and Inspect Hoses



Put Away Tools

Prepare For Safe Operation

Know The Work Area

Before you operate the mower thoroughly inspect the work area. Walk around the area and inspect the surfaces you will travel on when using the mower.

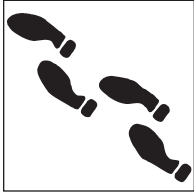

Walk
Around the
Worksite

Locate and avoid:

- Holes
- Drop-offs
- Obstacles (stumps)
- Excavations
- Standing water
- Deep mud
- Wet spots
- Soft soil
- Rough spots
- Power lines and apparatus
- Other utilities
- Any conditions which could cause collision, loss of control or tipover
- Steep slopes

Look for debris and obstacles by walking the area before you mow. Objects like wire, cable, rocks, tires, and metal objects that could damage or be thrown by the mower must be removed or marked clearly and avoided.

Correct unsafe conditions. Do not operate in problem areas where debris and obstacles cannot be removed or marked.

Analyze mowing area to determine:

- The most efficient mowing procedure.
- The height of the material to be mowed.
- Operating terrain conditions.
- How to best use forward mowing pattern.
- The potential for bystanders or passers-by to be exposed to thrown objects.

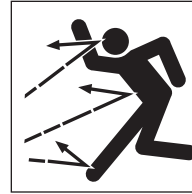

Remove or
Mark Debris and
Obstacles

Look Out For Others

Before starting equipment:

- Walk around the equipment.
- Check for anyone under, on or near the equipment.
- Clear everyone from these areas.
- Sound a warning.

Prepare For Safe Operation

Mount And Dismount Tractor Properly

Always use three-point contact when mounting or dismounting the tractor or mower. Face the machine when you enter or leave the machine. Three-point contact means that three out of four arms and legs are in contact with the machine at all times during mount and dismount.

Before mounting:

- Clean shoes and wipe hands. Clean steps and handholds of snow, ice, mud or oil.

During mounting and dismounting:

- Use handholds and step plates.
- Never grab steering wheels or controls for handholds.
- Never mount or dismount from a moving tractor.
- Never mount or dismount while carrying tools or objects that prevent three-point contact. Put parts or tools down. Maintaining proper contact, climb and then pick up the object.



Use
Three-Point
Contact



Clean Up
Slippery Areas

Prepare For Safe Operation

Tractor And Mower Controls Safety Test

Start the tractor following the specific procedures in the manufacturer's operator's manual. These procedures normally include:

- Fasten and adjust seat belt on your ROPS-equipped tractor.
- Check parking brake for engagement.
- Check PTO disengagement.
- Check all controls for Park position.
- Warn others in area before starting tractor.
- Start tractor following tractor manufacturer's recommended starting procedures.

WARNING! Avoid serious injury or death from unexpected machine movement. **Start the engine only from the operator's position. Never attempt to start the engine by shorting across starter terminals or reaching the key from the ground or outside the cab.**

After starting:

- Check all instruments, gauges and indicator lights for normal operation.
- Check all tractor controls, steering and brakes for proper function.

- Raise and lower mower to check for driveline bottoming out or engagement problems.
- Check the equipment for excessive vibration and unusual noises.

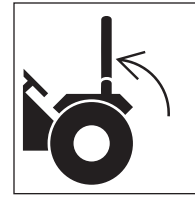
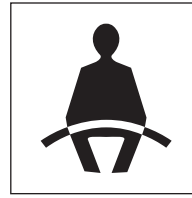

Use ROPS and Seat Belt



Start Only from Operator's Seat

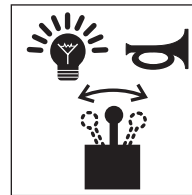

Check Instruments and Controls

Prepare For Safe Operation

- Use proper equipment shut down practices before inspecting equipment. Wait until all equipment motion has stopped before dismounting the tractor or mower.
- Do not operate mower unless tractor and mower are running properly. Place a "Do Not Operate" tag on the machine, remove the key and do not operate the mower until the problem is corrected.

Power Takeoff System

Be sure to operate the tractor at the mower's rated PTO rpm speed.

When operating tractors with transmission-driven PTO systems, a rotary mower will have a significant flywheel effect. The mower may continue to propel a tractor with a transmission-driven PTO system.

The tractor should be equipped and operated as follows:

- Install a driveline equipped with an over-running clutch.
- Give yourself sufficient maneuvering room and time by anticipating turns, stops and speed reductions.

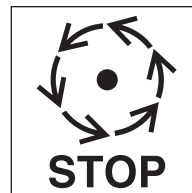

Do Not Dismount Until Equipment Motion Has Stopped

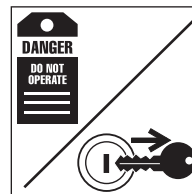

Use a "Do Not Operate" Tag

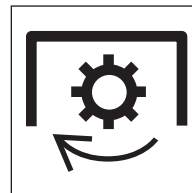

Use Proper PTO Speed

Prepare For Safe Operation

Hitching Mower To Tractor

Three-point hitch-mounted mowers:

- Refer to mower and tractor manufacturers' manuals.
- Place tractor's hydraulic power lift (rockshaft) selector lever in down position to avoid unexpected movement.
- Explain the hitching procedures to those operators who cannot read.
- Front-end weights may be needed to maintain steering control and front-end stability. Refer to the manufacturers' operator's manual(s).
- When backing the tractor up to the mower, NEVER allow anyone between the tractor and the mower.
- Attach the mower to the tractor three-point links and securely pin in position.
- Securely attach the driveline to the tractor PTO. Lower the master shield into place if it is movable. Push and pull on the driveline to ensure it is locked onto the PTO shaft.

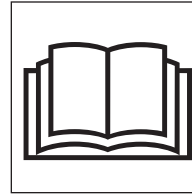

Read and Understand Manuals Before Operating



Maintain Proper Weight Distribution



No One Allowed Between Tractor and Mower



Avoid Entanglement, Use Guards and Shields

Prepare For Safe Operation

Pull-type hitch-mounted mowers:

- Refer to mower and tractor manufacturers' manuals.
- Remove three-point hitch quick coupler if equipped.
- Attach only to drawbar hitch.
- Adjust tractor drawbar length for 540 or 1000 rpm PTO operation.
- When backing the tractor up to the mower, NEVER allow anyone between the tractor and the mower.
- Properly attach the mower safety tow chain to the tractor.
- Securely attach the driveline to the tractor PTO. Push and pull on the driveline to ensure it is locked onto the PTO. Lower the master shield into place.
- Hook up the mower hydraulic hoses to the tractor.
- Make sure the wings, or raised mower decks, are supported by the cylinders before removing the transport locks. Never use force to release the transport or wing locks. The wings or deck could fall and crush you.

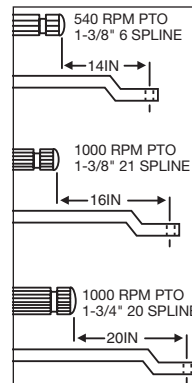

Tractor Drawbar Adjustment



Confirm Wings Are Supported Before Releasing Locks



Avoid Entanglement, Use Guards and Shields

Start Safely

Make The Right Start

Mow only in daylight or good artificial light conditions.

Avoid serious injury or death from mower-thrown objects or blade contact:

- Keep chain shields, flexible or solid deflector shields or discharge chutes in place and in good repair.
- Keep bystanders at least 300 ft (92 m) from mowing operation.
- Never direct mower discharge toward anyone.
- Keep hands, feet and other body parts away from rotating parts, blades and discharge openings.
- Do not operate mower in transport position.

Do not approach a mower until all motion has stopped.

Mower PTO drive engagement:

- Raise mower to maximum cutting height.
- Engage PTO at low engine rpm.
- Increase engine rpm to mower's rated rpm PTO speed.
- Lower mower to desired cutting height.
- Stop and shut down immediately if the mower strikes an obstruction.
- Inspect and repair any mower damage before resuming mowing.
- Do not operate mower with severe vibrations or with unusual noise.

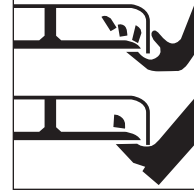

**Rotating Blades –
Keep Away**



**Do Not Operate a
Damaged Mower**

Mower-Thrown Objects

Depending on the designed purpose, mowers are designed to cut grass, weeds, brush and crops. The mower blades have been designed and tested for rugged use. The mower blades, however, are not intended to contact solid objects like rocks, concrete or metal. Such impact can cause broken objects to be thrown up to 300 ft (92 m). Bystanders should never be within 300 ft (92 m) of an operating rotary mower or within 100 ft (30 M) of a properly equipped disc mower.

Operate Safely

Mower shielding is designed to reduce the risk of thrown objects and must be properly maintained and in place during mowing operations.

The risk of serious injury or death from thrown objects can be significantly reduced by following three rules.

If all of these safety rules are not followed, the mowing operation must be stopped if anyone comes within the safety limit for the mower type.

First — Inspect the area prior to mowing and remove stones, branches, wire, cable, metal, glass and other solid objects before operating. Any objects that cannot be removed must be clearly marked and carefully avoided by the operator.

In non-crop areas with grass and weeds high enough to hide objects that could be struck by the blades, inspect the area and remove or mark large debris or obstacles.

Mow the area at an intermediate height. Inspect the area closely and remove or mark any remaining debris or obstacles. Mow again at desired final height.



**Follow
All Mower
Safety Rules**

Second — Mower-thrown object shielding must be used when operating near roads, parks, populated areas or other areas where thrown objects could injure bystanders or damage property. Follow the manufacturer's operator's manual.

Third — Cross diagonally when mowing through ditches, sharp dips, and drops. Raise the mower to prevent the mower blades from hitting the ground.

Operate Safely

Mower-Thrown Objects (continued)

Disc Mowers — When using a disc mower it is important to know the area to be mowed. If the operator has mowed the field before and is familiar with all obstacles that may be present, it is sufficient to watch ahead of the mower path for any additional objects that may have entered the field. Be ready to stop or avoid any objects that could be hazardous if thrown by the mower. If you plan to mow an unfamiliar field and it is next to a traveled road or people may be within 100 ft (30 m) of the mower you must inspect, and clean or mark the field.

Mowing In Reverse

Do not mow while traveling in reverse. Objects are more likely to be thrown and can travel further.

Shut off the PTO, wait for the blades to stop turning, raise the mower, and then back up.

Mow traveling in the forward direction.



**Do Not Mow
in Reverse**

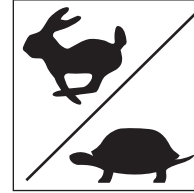

**Use Proper
Ground Speed**

Mowing Ground Speed

Proper ground speed depends on terrain conditions and grass type, density and height to be cut:

- Normal ground speed range is 2 to 5 mph.
- Use slower ground speed for mowing tall, dense grass.
- Use faster ground speed for mowing medium height, thin grass and under smooth terrain conditions.
- Use slower ground speed for mowing in rough, sloping or unfamiliar terrain.

Disc mowers are designed to use faster ground speeds for operating in fields clear of debris and surface hazards.

Operate Safely

Extremely Tall Grass Mowing

You may need to mow extremely tall, non-crop grass twice. (See page 13, **Mower-Thrown Objects**.)

First mowing pass:

- Shut the mower and tractor down using proper equipment shut down practice before dismounting tractor. (See page 18, **Proper Equipment Shut Down Practices**.)
- Inspect the area and remove or mark debris and obstacles.
- Cut grass higher (10-15 inches) to avoid hidden objects.

Second mowing pass:

- Shut the mower and tractor down using proper equipment shut down practice before dismounting tractor.
- Inspect the area and remove or mark debris and obstacles.
- Cut grass at desired height and, when possible, 90 degrees to the first mowing pass.

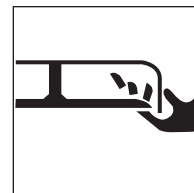

**Stop Blade
Before
Unclogging**

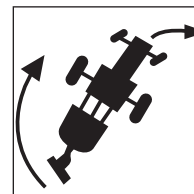

**Provide Adequate
Clearance for
Mower Swing**

Watch Equipment Clearances

Three-point hitch and side-mounted mowers have a larger turning arc than pull-type mowers. Allow sufficient clearance for mower swing while turning.

Do not allow bystanders near the tractor and mower when moving or transporting the tractor and mower.

Operate Safely

Under Mount Mower Safety Practices

When mowing with an under mount mower:

- Keep removable discharge chute in place and over discharge opening.
- Never stand on a mower housing when the tractor engine is operating.
- Distribute grass clippings with discharge chute facing mowed area.
- Before clearing a clogged mower or discharge chute, shut down your machine using proper equipment shut down practice. (See page 18, **Proper Equipment Shut Down Practices.**)

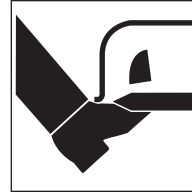

**Never Stand
on Mower –
Keep Away**

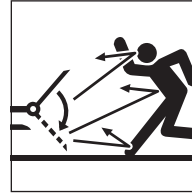

**Keep Chute
in Place**

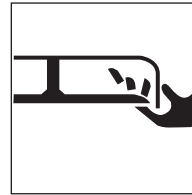

**Stop Blade
Before
Unclogging**

Operate Safely

Wing Or Boom Mower Overhead Obstruction Hazards And Risks

Check for overhead obstructions with raised wing or boom mowers to avoid serious injury or death by contact with:

- Electrical power lines and apparatus.
- Low tree limbs.
- Other overhead obstructions.
- Maintain specified distance from power lines and apparatus. Never approach energized power lines or apparatus with any part of your machine unless all local, state/provincial and federal (OSHA) required safety precautions have been taken. Use extreme caution.

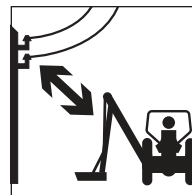

**Do Not
Approach Energized
Power Lines**

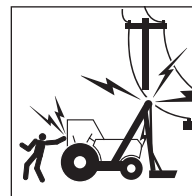

**Stay Clear
of Energized
Equipment**

DANGER! Avoid electrocution or serious injury from contact with or inadequate clearance to energized power lines or apparatus. **Do not allow the machine or attachment to approach or contact any power line. Do not approach or touch any machine in contact with a power line.**

Operate Safely

Wing And Side Mount Mowers Safety Practices

Raised wing positions reduce shielding protection and increases the thrown object and blade contact hazard risks.

Avoid possible serious injury or death by thrown objects or blade contact from raising and lowering wings during mowing operations:

- Do not mow with bystanders within 300 ft (92 m) of the mower.
- Be sure no one is near mower while raising or lowering wings.
- Shut off the PTO and wait for all rotating elements to stop before raising the mower deck or wing section.
- Only raise wing to clear objects in the mowing path or to match ground slope.
- Lower raised wing to ground after clearing object or ground slope conditions.
- Stop mowing if anyone approaches within 300 ft (92 m) of mowing area.

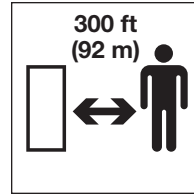

Keep Bystanders
Away from
Mowing Area

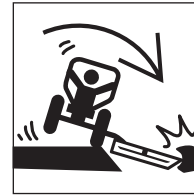

Avoid Hitting
Obstructions

Ditch Bank Mowing Safety Practices

Use extreme care when mowing ditch banks. Watch for washouts, eroded areas and mowing obstructions along the ditch banks. Hitting obstructions with side-mount or boom mowers may swerve the tractor's front end toward the ditch.

Operate Safely

Raised wing and boom mower ditch bank operations may reduce the mower's thrown object shielding effectiveness for the mower operator's protection.

- Use enclosed ROPS cabs, special protective enclosures and other operator shielding available from the manufacturer when performing these operations.
- Inspect mowing area and remove or mark all foreign objects and debris to be avoided by mower.

Uneven Terrain Mowing Safety Practices

Tractor and mower stability is reduced on slopes and uneven terrain.

As in all conditions when mowing, use tractors equipped with ROPS and seat belt. **Make sure the ROPS are raised and locked in place and always wear your seat belt.**

Prevent tractor and mower overturns and maintain equipment stability control:

- Review tractor and mower operator's manuals for operating safety practices on slopes and uneven terrain conditions. Explain the practices to those users and operators who cannot read.
- Avoid extremely steep slope operations.

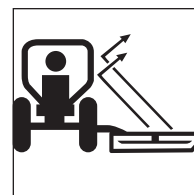

Use
Enclosed ROPS
Cabs or Protective
Enclosures

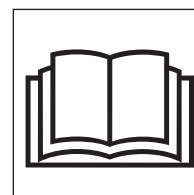

Read and
Understand
Manuals Before
Operating

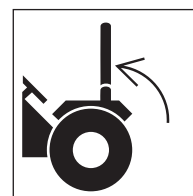

Use ROPS
and Seat Belt

Operate Safely

Uneven Terrain Mowing Safety Practices (continued)

- Use extreme care to maintain control over the equipment when operating in these conditions.
- Increase tractor stability by adding wheel weights, ballast and increasing wheel spacing to maximum. Refer to operator's manual for recommendations.
- Maintain minimum ground speed.
- Make wide and gradual turns.
- Avoid sudden starts, stops, and turns when operating up, down, or across slopes.
- **Do not** raise rear-mount or side-mount mowers or mower wings from the ground during these operations.
- Keep alert for holes, bumps, ruts, rocks, stumps or other obstructions that could overturn the machine.
- Avoid slippery ground conditions that could cause loss of control and overturn of tractor and mower.
- Avoid bottoming and striking the ground by diagonal crossing of sharp dips and drops.

Use extreme care in maintaining equipment stability during all uneven terrain and slope mowing operations. You are the final judge as to any slope that can be safely negotiated.

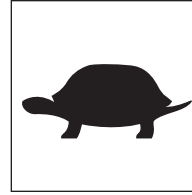

Maintain Control, Use Low Speeds



Add Ballast, Widen Wheel Spacing



Avoid Ruts, Bumps, Holes

Operate Safely

Road Transport Safety Practices

Before operating on public roads:

- Refer to tractor and mower manufacturers' operator's manuals for instructions.
- Explain the instructions to those users or operators who cannot read.
- Check local regulations for required equipment markings, lights, flashers, etc., while traveling on public roads. Lights are required on mowers that obscure tractor taillights and/or warning lights.
- When transporting the mower on a trailer, follow the manufacturer's detailed instructions for loading, tying down and unloading the mower.

Before transporting on public roads:

- Disengage PTO power to mower.
- Raise mower into transport position and engage transport lock.
- Lock mower wings in the transport position with approved locking devices.
- Attach towing safety chain between pull-type mower and tractor.
- Make sure lights, warning lights and reflectors are in place and visible.

- Check SMV (Slow-Moving Vehicle) emblem for visibility to any rear-approaching vehicle.

While transporting on public roads:

- Obey all local traffic regulations.
- Approach intersections with caution.
- Observe speed and traffic control signs.
- Avoid panic stops and sharp turns.

Be a courteous operator and pull over periodically and allow traffic to pass.

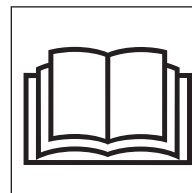

Read and Understand Manuals Before Operating

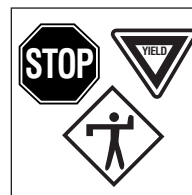

Obey Traffic Regulations

Park Safely

Parking Safety Practices

- Use designated or out-of-traffic areas.
- Use firm level ground locations.
- Set parking brake.
- Lower raised equipment to ground.

Shut down the mower and tractor using proper equipment shut down practice before dismounting tractor. (See page 18, **Proper Equipment Shut Down Practices.**)

Sloping ground parking locations:

- Position equipment across slope.
- Set parking brakes.
- Lower raised equipment to ground.
- Block tractor wheels.

Before temporarily parking and leaving disabled equipment near traffic areas:

- Remove equipment from public roads.
- Set out warning flags.
- Use tractor flashing warning lights.

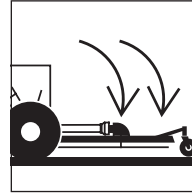

Shut Down Safely

Proper Equipment Shut Down Practices

Make proper equipment shut down an important habit.

Properly shutting down a tractor and mower can prevent accidents from occurring when the mower is left unattended. Shut down the mower following the specific procedures in the manufacturer's operator's manual.

These procedures will normally include:

- Reduce engine speed.
- Disengage PTO clutch and transmission drive.
- Idle engine for gradual cooling.
- Place all controls in PARK position.
- Set the parking brake.
- Lower mower to ground.
- Lower wings of wing mowers to ground.
- Shut off engine, lock ignition and remove key from the machine and take it with you.
- Wait for all moving parts to stop before dismounting.
- Relieve hydraulic pressure by moving hydraulic controls several times in all directions.
- Lock anti-vandalism covers and closures, if equipped, when equipment is unattended.
- Dismount carefully maintaining three-point contact.

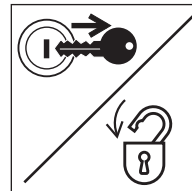
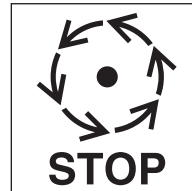
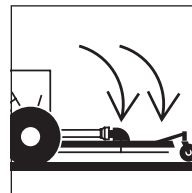
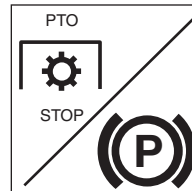

Shut Down Safely

Dismounting Properly

- Never dismount from moving equipment.
- Never jump from any machines.
- Dismount carefully.
- Check for slippery steps.
- Keep feet and hands away from controls.
- Use handholds and steps during dismount.
- Face machine and use three-point contact (2 hands and 1 foot or 2 feet and 1 hand).

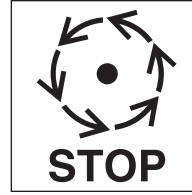

Wait for
Moving Parts
to Stop



Use Three-Point
Contact,
Face Machine

Perform Maintenance Safely

Maintain Your Equipment

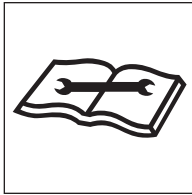

Maintain
Equipment

Be sure to maintain the equipment according to manufacturer's instructions. Regularly check the operation of the protective and safety devices.

Do not perform any work on a tractor or mower unless you are authorized and qualified to do so.

If you have been authorized to do maintenance, **read the operator's and service manuals.** Study the instructions; check the lubrication charts; examine all the instruction messages on the machine. Maintenance can be hazardous unless performed properly. Be sure you have the necessary skill, information, correct tools and equipment to do the job.

WARNING! Do not modify equipment or add components not approved by the manufacturer. Use parts, lubricants and service techniques recommended by the manufacturer.

Mower Parts And Your Safety

Mower manufacturers use specific fasteners and specially designed parts to meet mowing operations requirements. Critical parts (self-locking blade bolts, blades, pins, shields and other special items) have specific strength, design and fit requirements for the make and model mower you are using.

Avoid possible death or serious injury from unapproved parts or modifications:

- Do not substitute common hardware for original manufacturer's blade bolts or other special part items.
- Do not substitute for blades, pins, shields or other critical parts.
- Do not use higher strength bolts to replace original manufacturer's shear bolts.

Perform Maintenance Safely

Prepare Yourself

Wear personal protective clothing and Personal Protective Equipment (PPE) issued to you or called for by job conditions. You must **ALWAYS** wear safety glasses with side shields.

You may also need:

- Hard hat
- Safety shoes
- Safety glasses, goggles or face shield
- Apron and gloves
- Hearing protection
- Welding helmet or goggles
- Respirator or filter mask

Wear whatever is needed—don't take chances.

Keep hands—and clothing—away from all moving parts. Don't wear dangling ties, loose sleeves, rings, watches, or long hair.

WARNING! Prevent death or serious injury from entanglement. **Do not wear loose clothing or accessories. Stay away from all rotating components when the engine is running.** Contact, wrapping or entanglement with rotating or moving parts could result in death or serious injury.



Avoid Rotating Parts

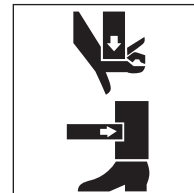

Avoid Pinch Points

Perform Maintenance Safely

Wear a rubber apron and rubber gloves when working with corrosives. Wear gloves and safety shoes when handling wooden blocks or sharp-edged metal.

Always use safety glasses, goggles or a face shield. They provide eye protection from fluids under pressure, during grinding and while servicing batteries. Protection is also needed from flying debris, liquids and loose material produced by equipment, tools and pressurized air/water.

Wear a face shield and follow manufacturer's instructions when you disassemble spring-loaded components or work with battery acids. Wear a welding helmet or goggles with a shaded filter when you weld or cut with a torch.

Do not sand, grind, flame-cut, braze or weld without a NIOSH-approved respirator or appropriate ventilation. If welding is required on this machine, refer to the manufacturer's operator's or service manuals or consult your equipment dealer for proper procedures.

Keep pockets free of all objects that could fall out—and drop into machinery.

Handle tools and heavy parts sensibly—with regard for yourself and other persons. Lower items—don't drop them.



Clean Slippery Surfaces

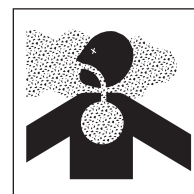

Ventilate Work Area

Prepare The Work Area

- Position the mower in a level area out of the way of other working equipment.
- Make sure there is adequate light, ventilation and clearance.
- Remove oil, grease or water to eliminate any slippery surfaces.
- Clean around the area to be serviced to minimize contamination.

Perform Maintenance Safely

Prepare The Machine

Stored energy sources (electrical, mechanical, hydraulic, pneumatic, chemical, thermal, etc.) must be controlled or reduced to a practical minimum before performing any maintenance, repair or service procedures.

Safety practices to prevent potential injuries from energy-releasing sources:

- Disengage PTO before shutting off engine.
- Place controls in PARK or NEUTRAL before shutting off engine.
- Set parking brake or block wheels.
- Allow all moving parts to stop.
- Lower mower to ground.
- Lower wings to ground on wing mowers.
- Shut off tractor engine.
- Relieve hydraulic system pressure by moving controls several times in all directions.
- Lock ignition, remove key and take it with you.
- Look and listen for evidence of moving parts before dismounting.
- Securely support or block up mower before working underneath mower or other lifted components.

- Securely support, block up, or lock up mower wings with approved locking devices before working near or underneath a wing mower.
- Relieve pressure before disconnecting or disassembling any pressurized system.
- Block or relieve spring pressure before disassembling any spring-loaded mechanism.
- Securely support or block up any raised machine component before working on it.
- Avoid flames, sparks, or smoking near any fuel, hydraulic fluid or other flammable material such as mowing debris.



Prepare
Machine Systems
for Service

Perform Maintenance Safely

Attach a “DO NOT OPERATE” warning tag to the control levers and remove the ignition key if the mower should not be operated. Take the key with you.

Install approved support device(s) when working under or near raised equipment.

WARNING! Unsupported raised mowers or other equipment may drop unexpectedly. **Never go under equipment when raised unless supported by an approved support device(s).** Death or serious crushing injury could result from falling equipment.

Remove only guards or covers that provide access to the area being serviced. Replace all guards and covers when work is complete.

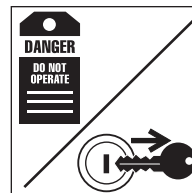

Use a
“Do Not Operate”
Tag



Use
Approved
Support Device



Replace
All Guards

Perform Maintenance Safely

Use Proper Ventilation

If it is necessary to run an engine in an enclosed area, remove the exhaust fumes from the area with an exhaust pipe extension. If you do not have an exhaust pipe extension, make sure you open the doors and get outside air into the area.

WARNING! Prevent possible injury. **Never work on machinery with the engine running unless instructed by the manufacturer's manuals for specific service.**

WARNING! **Never operate any type of engine without proper ventilation—EXHAUST FUMES CAN KILL.**

Use Jacks And Hoists Carefully

Safety stands or blocks must be located on a rigid part of the mower. Do not position stands under axles or wheel supports that may rotate.

If you must work beneath raised equipment, always use wood—**not concrete**—blocks, jack-stands or other rigid and stable supports. When using jacks or hoists always be sure they are adequately supported.

WARNING! Prevent possible crushing injury. **Never use concrete blocks for supports.** They can collapse under even light loads.

Make sure the hoists or jacks you use are in good repair. Never use jacks with cracked, bent, or twisted parts. Never use frayed, twisted or pinched cables. Never use bent or distorted hooks.

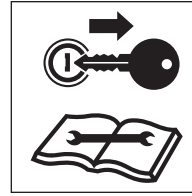

Remove Key and Read Maintenance Manual

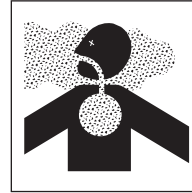

Ventilate Work Area



Use Proper Support for Raised Equipment

Perform Maintenance Safely

Common Maintenance Safety Practices

Fuel Hazards

WARNING! Always use approved fuel containers and/or dispensing equipment.

Fuels are flammable, so observe these practices to reduce the possibility of a serious accident.

- Shut off engine and ignition during refueling.
- Always ground the fuel nozzle against the filler neck to avoid sparks.
- Keep sparks and open flames away from fuel.
- Do not smoke while refueling or when handling fuel containers.
- Do not cut or weld on or near fuel lines, tanks or containers.
- Do not overfill the tank or spill fuel. Clean up spilled fuel immediately.

Engine Coolant Hazards

Liquid cooling systems build up pressure as the engine gets hot, so **use extreme caution before** removing the radiator cap.

Be sure to:

- Stop the engine and wait for the system to cool.
- Wear protective clothing and safety glasses.
- Turn the radiator cap slowly to the first stop to allow the pressure to escape before removing the cap completely.



No Smoking and No Open Flames

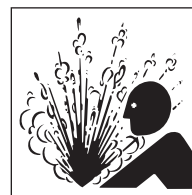

Remove Radiator Cap Slowly

Perform Maintenance Safely

Hydraulic System Hazards

The hydraulic system is under pressure whenever the engine is operating and may hold pressure even after the engine is shut off. Cycle all hydraulic controls including the auxiliary hydraulic control after the engine is shut down. Relieve trapped pressure in the lines after the attachments are shut down and resting on the ground.

During inspection of the hydraulic system:

- Wait for fluid to cool before disconnecting the lines. Hot hydraulic fluid can cause SEVERE BURNS.
- **Do not** use your hand to check for leaks. Instead, use a piece of cardboard or paper to search for leaks.
- Wear appropriate eye protection. Hydraulic fluid can cause permanent eye injury.

WARNING! Hydraulic fluid under pressure can penetrate the skin or eyes and cause serious injury, blindness or death. Fluid leaks under pressure may not be visible. **Use a piece of cardboard or wood to find leaks, not your hand. Wear a face shield or safety goggles for eye protection.** If fluid is injected into the skin, it must be removed within a few hours by medical personnel familiar with this type of injury.

When venting or filling the hydraulic system, loosen the filler cap slowly and remove it gradually.

Never reset any relief valve in the hydraulic system to a pressure higher than recommended by the manufacturer.

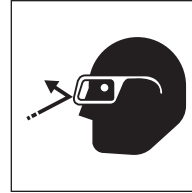

Wear
Eye Protection



High Pressure
Fluid Can Inject
Into the Body

Perform Maintenance Safely

Electrical System Hazards

Before working on the electrical system, disconnect the battery cable(s).

- Remove the battery negative (-) cable(s) first.
- When reconnecting the battery, connect the battery negative (-) cable(s) last.

The liquid in batteries contains acid, which is a POISON and can cause SEVERE CHEMICAL BURNS.

Avoid Injury

- Wear a face shield to prevent contact with your eyes.
- Wear chemical-resistant gloves and clothing to keep electrolyte off your skin and regular clothing.

WARNING! Electrolyte will damage eyes or skin on contact. **Always wear a face shield to avoid electrolyte in eyes.** If electrolyte contacts eyes, flush immediately with clean water and get medical attention. **Wear chemical-resistant gloves and protective clothing to keep electrolyte off skin.** If electrolyte contacts exposed skin or clothing, wash off immediately

with clean water. **If electrolyte is ingested,** seek medical attention immediately. NEVER give fluids that would induce vomiting.

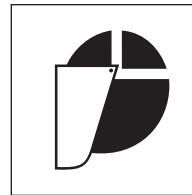

Wear
Face Protection



Wear
Protective
Clothing

Perform Maintenance Safely

Avoid Explosion

WARNING! Avoid possible serious injury from explosion. Lead-acid batteries produce extremely explosive gases especially when being charged. **Keep arcs, sparks, flames and lighted tobacco away.**

- Do not smoke near batteries.
- Keep arcs, sparks and open flames away from batteries.
- Provide adequate ventilation.

Never check the battery by placing a metal object across the battery posts — the resulting spark could cause an explosion.

WARNING! Avoid possible serious injury from battery explosion. **Do not charge a battery or boost start the engine if the battery is frozen.** Warm to 60°F (15.5°C) or the battery may explode and could cause serious injury.

Safety rules during battery boost starting:

- Follow the instructions for proper “battery boost starting” as specified in the manufacturer’s manual.
- Be sure the machines are not touching.

- Observe the polarity of the batteries and connections.
- Make the final cable connection to the engine or the furthest ground point away from the battery. Never make the final connection at the starter or dead battery—sparks may ignite the explosive gases present at the battery.
- When disconnecting cables after jump starting, remove the cables in reverse order of connection (e.g., final connection first).

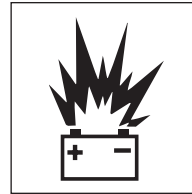

Avoid Sparks and Open Flames Near Batteries

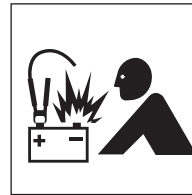

For Boost Starting Observe Polarity and Make Final Connection at Ground Point

Perform Maintenance Safely

Tire And Wheel Maintenance

Check your tires and wheels daily because the stability of the tractor and mower can be dramatically affected by tire pressure or damage to tires or wheels.

Check tires for:

- Correct pressure.
- Cuts and bulges.
- Nails or other punctures.
- Uneven or excessive wear.
- Condition of valve stems and caps.

Check wheels for:

- Damage to the rims.
- Missing or loose lug nuts or bolts.
- Misalignment.

All tire service should be performed by a qualified tire service center or by an authorized service person who has been properly trained in the procedures and use of safety equipment designed for tire servicing.

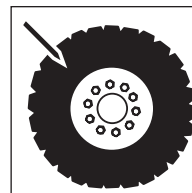

Check Tires and Wheels for Damage

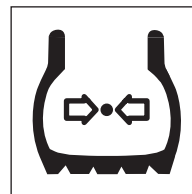

Maintain Proper Tire Pressure

Perform Maintenance Safely

Tire And Wheel Maintenance (continued)

WARNING! The types of wheels and tires usually found on this equipment require special care when servicing to prevent death or serious injury.

Do not inflate the tires above the recommended pressure. Be sure to replace tire ballast if equipped. See manufacturer's specifications for ballast requirements.

Keep wheel lug nuts tightened to manufacturer's recommendations.

A rise in tire pressure during operation is normal, and should NOT be reduced.

Never reinflate a tire that has been run flat or seriously underinflated without removing the tire from the wheel. Have the tire and wheel closely inspected for damage before remounting.

When adding air to a tire, do so from a distance. Use a long hose with self-attaching chuck. Always stand behind tread when adjusting tire pressure.

Do not inflate tires with flammable gases or from systems using an alcohol injector.

Never cut or weld on a wheel with an inflated tire mounted on it. This could cause explosive decompression.

Check that the tire size and wheel are correctly matched.

When replacing the tires, ensure the tires are of the appropriate rating specified by the manufacturer.

Tires should not be operated at speeds higher than their rated speed. Most agricultural tires are rated for 20mph maximum speed.

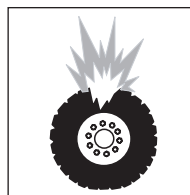

Perform Maintenance Safely

Complete Service And Repairs Before Machine Is Released

Tighten all bolts, fittings, and connections to torques specified by the manufacturer.

Install all guards, covers, and shields after servicing. Replace or repair any damaged parts. Refill and recharge pressure systems only with manufacturer approved or recommended fluids.

Start the engine and check for leaks. (See page 23, **Hydraulic System Hazards**.) Operate all controls to make sure the tractor and mower are functioning properly. Test the machine if necessary. After testing, shut down and check the work you performed. Are there any missing cotter pins, washers, locknuts, etc.? Recheck all fluid levels before releasing the equipment for operation.

All parts should be inspected during repair and replaced if worn, cracked or damaged. Excessively worn or damaged parts can fail and cause injury or death.

Replace any damaged or illegible safety signs.



Mower Blade Maintenance

Do not take chances using damaged or bent blades. The mower manufacturers from the Association of Equipment Manufacturers (AEM) and the Farm Equipment Manufacturers Association (FEMA) advocate that you DO NOT reuse, straighten, hard face or weld mower blades. Death or serious injury could result if a broken blade is thrown from a mower.

Perform Maintenance Safely

Mower Blade Maintenance (continued)

– How are mower blades made?

Mower blades are made of high strength alloy spring steel. They are hot-forged and shaped to meet the manufacturer's individual specifications, then heat treated and tempered to a high strength, ductile state to reduce the possibility of breaking while mowing. Blades are tested to ensure they meet strength, hardness, and ductility standards. If a blade fails to meet any of these specifications, it will not be used on the mower.

– What happens when a mower blade bends?

It takes a great amount of impact force to bend the blade. This impact force often results in the blades being gouged or chipped. After a blade is damaged by a gouge or chip a blade failure is much more likely to occur. When a blade is severely bent, a microscopic crack may be created in the blade. Straightening the blade does not remove or repair this crack, but may cause additional cracks. Additional stresses during mowing operations can result in an unexpected blade failure.

- **Avoid bending blades.** Help prevent mower blades from bending or cracking by avoiding contact with solid objects. Mower blades are intended to cut grass, shrubs, woody vegetation, and small trees and limbs. They are not intended to contact solid objects such as rocks, concrete, or steel posts. Inspect the area prior to mowing. Remove or clearly mark any solid objects and mow around them.
- **Replace damaged blades!** Inspect the mower blade(s) daily or after hitting any solid object. If a mower blade becomes damaged (bent, gouged, cracked) or worn more than 25 percent of the original size, it should be removed and replaced with a new blade. Always use the original manufacturer's blades. Aftermarket brand blades may not meet the mower manufacturer's strength, hardness and ductility requirements.
- **Do not take chances mowing with damaged or bent blades.** Using a damaged or straightened mower blade can result in the blade breaking and being thrown into the operator or a bystander causing death or serious injury. The price of a new blade is small compared to the potential for the serious injury that could result from a bent or broken blade being thrown from the mower.

Final Word To The User

You have just finished reading the AEM Industrial and Agricultural Mower Manual. It is impossible for this manual to cover every safety situation that you may encounter on a daily basis. Your knowledge of these safety precautions and your application to the

basic rules of safety will help to build good judgment in all situations. Our objective is to help you develop, establish and maintain good safety habits to make operating an Industrial and Agricultural Mower easier and safer for you.

This manual is another in a series on the safe operation of machinery published by AEM. Many pictorials in this safety manual can be found and downloaded at <http://pictorials.aem.org>. For additional publications visit our website at www.safetymaterials.org.



ASSOCIATION OF
EQUIPMENT MANUFACTURERS

e-mail safetymaterials@aem.org
www.aem.org

CORTADORA
DE CÉSPED INDUSTRIAL/
PARA AGRICULTURA

www.aem.org



MANUAL DE SEGURIDAD

PARA EL PERSONAL DE OPERACIONES Y MANTENIMIENTO

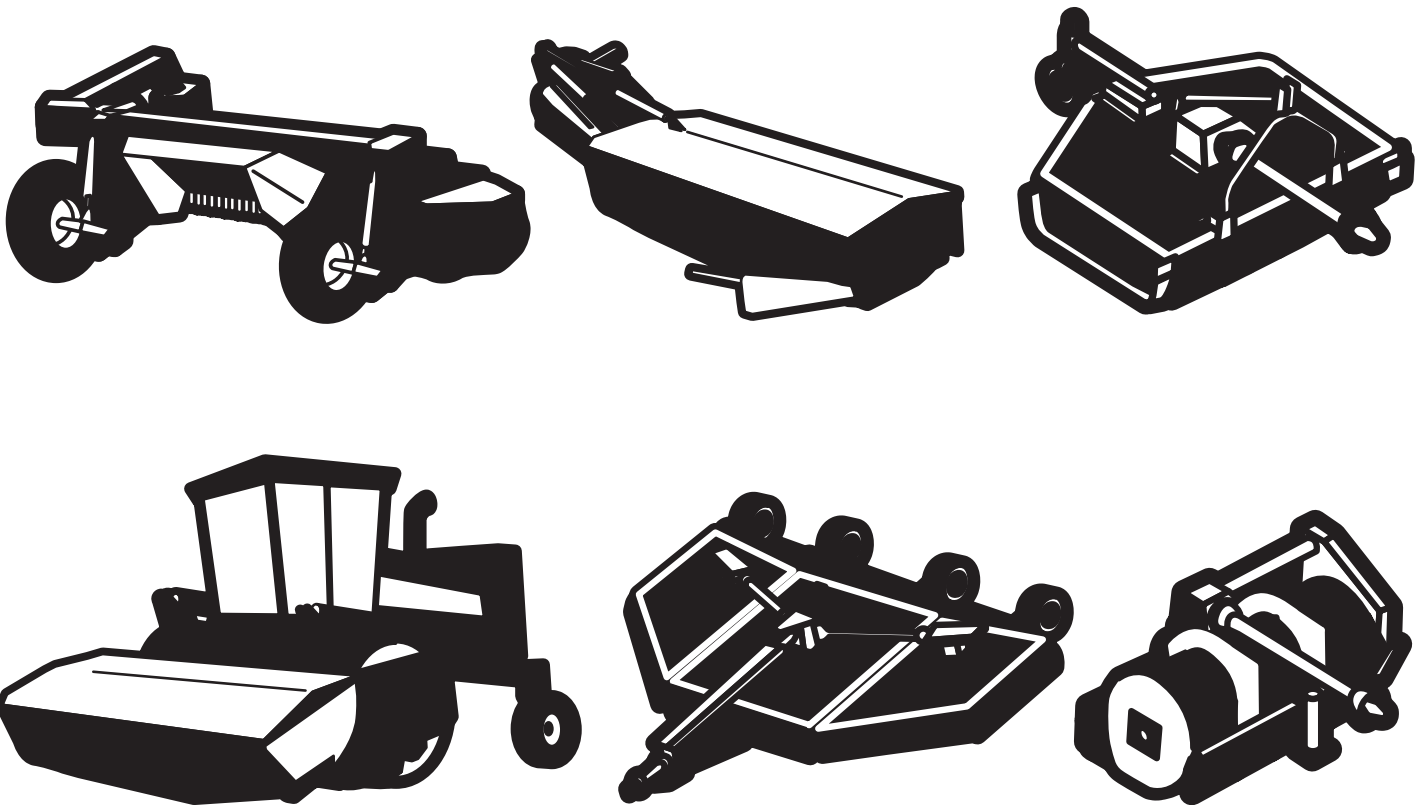

Contenido

Reconocimiento	2
Introducción	2
Alertas de seguridad	3
Palabras para el usuario/operador	3
Cortadora de césped industrial/para agricultura	4
Cumplimiento del programa de seguridad	5
Preparación para una operación segura	9
Arranque con seguridad	13
Operación con seguridad	13
Estacionamiento seguro	18
Apagado con seguridad	18
Realización de mantenimiento con seguridad	19
Palabras finales para el usuario	26

Reconocimiento

Deseamos reconocer las contribuciones de los miembros del Consejo de Fabricantes de Cortadoras de Césped Industriales/para Agricultura para la preparación de este Manual de seguridad.

AVISO DE PROTECCIÓN DE COPYRIGHT

Copyright, 2010, por la Asociación de Fabricantes de Equipos (Association of Equipment Manufacturers). Todos los derechos reservados. Queda prohibida la reproducción o difusión parcial o total de este trabajo por cualquier medio sin consentimiento previo por escrito de la Asociación de Fabricantes de Equipos.

Copyright 2010© AEM (Asociación de Fabricantes de Equipos)
Revisado el 01/03, 09/10

Introducción

Este manual de seguridad está destinado a señalar algunas de las situaciones de seguridad básicas que pueden surgir durante la operación y el mantenimiento normales de la máquina y a instruirlo en prácticas de seguridad para manejar estas condiciones. Este manual **NO** sustituye los manuales del operador del fabricante de la cortadora de césped.

Puede ser necesario tomar precauciones adicionales o algunas de las instrucciones pueden no ser pertinentes, dependiendo del equipo, los accesorios y las condiciones del sitio de trabajo o del área de servicio. El fabricante no tiene control directo sobre la aplicación, la operación, la inspección o el mantenimiento del equipo. Por lo tanto, es **SU** responsabilidad utilizar prácticas de seguridad correctas en estas áreas.

La información que se proporciona en este manual complementa la información específica sobre la máquina que contienen los manuales del operador del fabricante. Puede haber otra información que afecte la operación segura de la máquina en los letreros de seguridad o en los requisitos del seguro, programas de seguridad y capacitación del empleador, códigos de seguridad, leyes federales, locales, estatales o provinciales, reglas y ordenanzas.



Lea y asegúrese
de comprender los
manuales antes
de comenzar la
operación



¡IMPORTANTE! Antes de hacer funcionar la cortadora de césped, asegúrese de contar con los manuales del operador del fabricante para esta máquina y todos los accesorios. Si faltan los manuales del fabricante, solicite manuales de repuesto a su empleador, al concesionario de los equipos o directamente al fabricante. Guarde este manual de seguridad y los manuales del fabricante con la máquina en todo momento. Lea y asegúrese de comprender todos los manuales.

Se encuentra disponible el video AEM Mower Safety Practices (Prácticas de seguridad para la cortadora de césped de AEM) para capacitar y reforzar prácticas de seguridad correctas. Se alienta a los operadores a ver periódicamente el video de seguridad.

Alertas de seguridad

Símbolo

Este símbolo de alerta de seguridad significa: **“¡ATENCIÓN! ¡MANTÉNGASE ALERTA! ¡SU SEGURIDAD ESTÁ EN RIESGO!”**

El símbolo de alerta de seguridad identifica mensajes de seguridad importantes sobre el equipo, sobre letreros de seguridad, en manuales u otros lugares. Cuando vea este símbolo, manténgase alerta ante la posibilidad de muerte o lesiones personales. Siga las instrucciones del mensaje de seguridad.



- Motivos por los cuales la seguridad es importante:
- Los accidentes provocan discapacidad y muerte.
 - Los accidentes cuestan.
 - Los accidentes pueden evitarse.

Palabras indicativas

Las palabras indicativas son palabras distintivas que típicamente se encontrarán en letreros de seguridad de la cortadora de césped y otros equipos del sitio de trabajo. Estas palabras también se pueden encontrar en este manual y en los manuales del fabricante. Están destinadas a alertar al operador sobre un riesgo y el grado de gravedad del riesgo.



DANGER (PELIGRO) indica una situación riesgosa que, si no se evita, resultará en una lesión grave o la muerte.



WARNING (ADVERTENCIA) indica una situación riesgosa que, si no se evita, podría resultar en una lesión grave o la muerte.



CAUTION (PRECAUCIÓN) indica una situación que, si no se evita, podría resultar en lesiones leves o moderadas.



NOTICE (AVISO) indica un mensaje de daños a la propiedad.

Palabras para el usuario/operador

Es **SU** responsabilidad leer y asegurarse de comprender el manual de seguridad y los manuales del fabricante antes de hacer funcionar esta máquina. Este manual de seguridad lo lleva paso a paso a través de su día de trabajo.

El reconocimiento de los riesgos y la prevención de accidentes dependen de que usted esté alerta, sea cuidadoso y se capacite correctamente para la operación, el transporte, el mantenimiento y el almacenamiento de este equipo.

Se han suministrado gráficos útiles para comprender el texto.

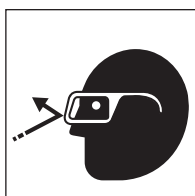

Lea y asegúrese de comprender todos los letreros de seguridad

Recuerde que **USTED** es la clave de la seguridad. Las prácticas de seguridad correctas lo protegen no sólo a usted sino también a las personas que lo rodean. Estudie este manual y los manuales del fabricante para su máquina en particular. Transfórmelos en una parte activa de su programa de seguridad. Tenga presente que este manual de seguridad está escrito para cortadoras de césped industriales/para agricultura.

Contáctese con el fabricante del equipo si le queda alguna pregunta sobre la operación segura después de estudiar los manuales del operador del fabricante y este manual de seguridad.

Tome todas las demás precauciones habituales y acostumbradas para un trabajo seguro y, sobre todo:

RECUERDE:

¡LA SEGURIDAD DEPENDE DE USTED!

¡PUEDE EVITAR LESIONES GRAVES O MUERTE CAUSADAS POR PRÁCTICAS LABORALES NO SEGURAS!

Cortadora de césped industrial/para agricultura

Tipos de cortadora de césped industrial/para agricultura

Las cortadoras de césped se usan para recortar pasturas, desmenuzar residuos de cultivos, cortar arbustos, realizar desbroce pesado, cortar la hierba en vías de agua, derechos de paso, costados de caminos o autopistas. Además, estas cortadoras se usan para cortar la hierba y otras plantas en zonas públicas como parques y cementerios.

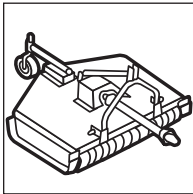

Giratorio

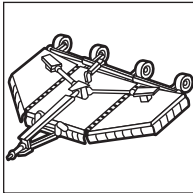

Giratorio con lateral plegable

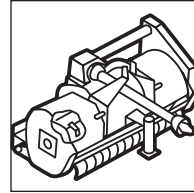

Triturador

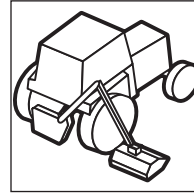

Aguilón

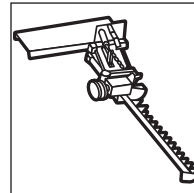

Barra en forma de hoz

Cortadora de césped industrial/para agricultura

Tipos de cortadora de césped de disco para agricultura

Las cortadoras de césped de disco están diseñadas y equipadas para cortar cultivos de heno a mayor velocidad de desplazamiento.

Las cortadoras/acondicionadoras de disco cortan y acondicionan los cultivos.

Las formadoras de hileras autopropulsadas cortan el heno y lo acondicionan en hileras.

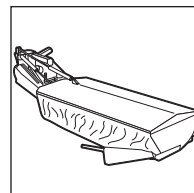

Cortadora de césped de disco

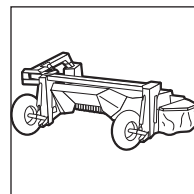

Cortadora/acondicionadora de disco

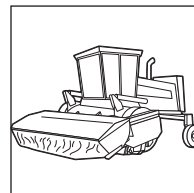

Formadora de hileras autopropulsada

Cumplimiento del programa de seguridad

Protéjase a sí mismo

Use la ropa de protección personal y los equipos de protección personal (PPE) que se le proporcionen o que requieran las condiciones del trabajo. **SIEMPRE** debe usar gafas de seguridad con escudos laterales.

Puede necesitar también:

- Casco
- Calzado de seguridad
- Antiparras de seguridad o protección facial
- Guantes gruesos
- Protección para oídos
- Indumentaria reflectiva
- Indumentaria impermeable
- Respirador o máscara con filtro

Use la ropa necesaria; no corra ningún riesgo.

¡ADVERTENCIA! Evite lesiones graves o muerte por enredos. **No use ropa floja ni accesorios. Ate el cabello largo. Manténgase alejado de todos los componentes giratorios cuando el motor está en funcionamiento.** El contacto, el enrollado o el enredo con piezas giratorias o móviles podrían resultar en lesiones graves o la muerte.



Evite quedar enredado

Cumplimiento del programa de seguridad

- Lea, asegúrese de comprender y siga las instrucciones escritas del fabricante que se encuentran en el manual del operador y en los letreros de seguridad sobre la cortadora y el tractor.
- Obtenga capacitación para la operación de la cortadora y el tractor.
- Aproveche los programas de capacitación que se ofrecen en su zona.
- Solicítele al distribuidor de equipos o al supervisor que le explique cualquier información que no comprenda.
- Explique las instrucciones escritas de los manuales del operador y los letreros de seguridad a los usuarios u operadores que no puedan leerlas.
- Inspeccione la cortadora y el tractor diariamente antes de hacerlos funcionar. Asegúrese de que todas las guardas se encuentren en su lugar y de que el equipo funcione correctamente.
- Nunca fume mientras lo está manejando. Nunca llene el depósito de combustible con el motor en funcionamiento o cerca de una llama abierta.
- Asegúrese de tener visibilidad adecuada e iluminación suficiente.
- Sepa cuáles son los puntos donde puede quedar atrapado y las partes giratorias. Su conocimiento puede evitar accidentes.
- Nunca intente hacer funcionar los controles, excepto desde el asiento del operador. Las funciones controladas de manera incorrecta pueden producir el movimiento imprevisto de la máquina y resultar en lesiones graves o muerte.
- Apague la cortadora y el tractor antes de descender. (Consulte la página 18, **Prácticas correctas de apagado de los equipos.**)

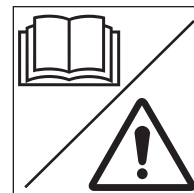

Lea, asegúrese de comprender y siga las indicaciones de los manuales y los letreros de seguridad



Evite las partes giratorias

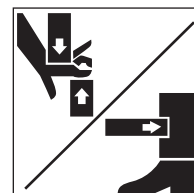

Sepa cuáles son y evite los puntos donde pueda quedar atrapado

Cumplimiento del programa de seguridad

Evite las lesiones provocadas por equipos elevados

Evite posibles lesiones de aplastamiento por caídas de la cortadora u otros equipos elevados.



**Evite ser aplastado –
Bloquee o apoye
con seguridad la
cortadora**

Antes de trabajar cerca o debajo de partes levadas de la cortadora o de los equipos:

- Apoye o bloquee con seguridad las partes elevadas de la cortadora o los equipos de acuerdo con el manual del operador.
- Apoye, bloquee o trabe con seguridad los laterales con dispositivos de bloqueo aprobados o descienda las partes de la cortadora o de los equipos hasta el suelo.
- Use trabas de transporte cuando transporte la cortadora por la vía pública.

Evite lesiones producidas por líquidos a alta presión

Evite las lesiones por inyección de fluidos debidas a fugas de líquidos a alta presión.



**El fluido a alta
presión puede
inyectarse en el
cuerpo**

Cumplimiento del programa de seguridad

Evite lesiones por incendios y explosiones

Aplique el freno de estacionamiento, apague el motor de la cortadora y del tractor y retire la llave mientras llena el depósito de combustible. Tenga precaución adicional cuando carga combustible en un motor caliente. Nunca fume mientras carga combustible. Evite las chispas conectando a tierra la boquilla de combustible contra el cuello de llenado del depósito.

Los vapores de un depósito de combustible vacío son explosivos. Nunca suelde o realice cortes en líneas, depósitos o contenedores de combustible.

Retire toda la basura o los residuos de corte de la máquina todos los días o según sea necesario. Mantenga los residuos alejados del motor, el escape, los embragues y otras fuentes de calor. Use supresores de chispas, según corresponda, en el sistema de escape del motor. Asegúrese de que no haya trapos con aceite u otro material inflamable almacenado en la máquina.

Revise en busca de fugas de combustible, aceite o fluido hidráulico. Repare las fugas y limpie la máquina antes de hacerla funcionar.

El éter/fluido para arranque en frío es inflamable. No fume cuando usa éter/fluido para arranque en frío. Siempre siga las instrucciones del recipiente y de los manuales del

Si un fluido se inyecta en la piel, debe ser extraído dentro de pocas horas por personal médico familiarizado con este tipo de lesión.

Las fugas de fluido bajo presión pueden no ser visibles. Al verificar en busca de fugas o cuando trabaja cerca de sistemas presurizados:

- Lea las prácticas de seguridad recomendadas en los manuales del operador del fabricante.
- Use una protección facial o antiparras de seguridad para proteger los ojos.
- Use un cartón o una madera para buscar fugas; **NO use las manos.**
- Alivie la presión del sistema antes de desconectar líneas.
- Busque y repare las líneas, los tubos y las mangueras dañados o con fugas.
- Busque y apriete las conexiones flojas.
- Purgue el aire del sistema antes de hacerlo funcionar.

operador del fabricante correspondientes a la cortadora de césped. No use éter/fluido para arranque en frío si el motor está equipado con bujías de precalentamiento u otro dispositivo de precalentamiento.

Siempre use solvente no inflamable para limpiar las partes. No use gasolina, combustible diesel u otros fluidos inflamables. Almacene todos los fluidos y materiales inflamables lejos de la máquina y de la zona de trabajo.

Sepa dónde se guardan los extintores de incendios, cómo funcionan y para qué tipo de incendio están destinados. Verifique la disponibilidad de los extintores de incendios de acuerdo con las instrucciones del fabricante. Asegúrese de que cada tractor esté equipado con un extintor de incendios.



**No fumar;
evitar las llamas
abiertas**

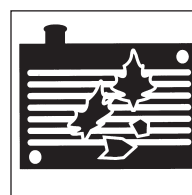

**Retire los
residuos a diario
o según sea
necesario**

Cumplimiento del programa de seguridad

¡Manténgase alerta!

Sepa dónde obtener asistencia. Sepa cómo usar un equipo de primeros auxilios y un extintor de incendios/ sistema de supresión de fuego.

¡Manténgase informado!

Aproveche los programas de capacitación que se ofrecen.

¡Tenga cuidado!

El error humano es causado por muchos factores: descuido, fatiga, sobrecarga, preocupación, desconocimiento de la máquina por parte del operador, fármacos y alcohol, entre muchos otros. Los daños al tractor o la cortadora de césped se pueden arreglar en un tiempo breve, pero las lesiones o la muerte tienen un efecto perdurable.

Por su seguridad y la de los demás, aliente a sus compañeros de trabajo a actuar con seguridad.

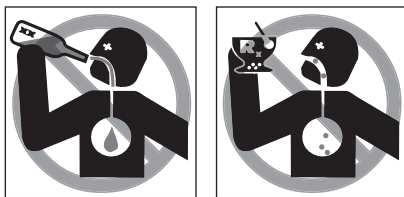

Nunca use fármacos o alcohol mientras está operando la máquina

Para una operación segura

Usted debe ser un operador cualificado y autorizado para operar la máquina correctamente. Debe comprender claramente las instrucciones por escrito que proporciona el fabricante, recibir capacitación (que incluya la operación real de la cortadora de césped) y conocer las reglas y ordenanzas de seguridad correspondientes al sitio de trabajo. Una buena práctica de seguridad consiste en señalar y explicar los letreros y las prácticas de seguridad y asegurarse de que otras personas comprendan la importancia de seguir estas instrucciones.

¡ADVERTENCIA! Los fármacos y el alcohol afectan la capacidad de alerta y de coordinación del operador, así como su capacidad para operar los equipos con seguridad. **Nunca use fármacos o alcohol mientras opera el equipo de la cortadora. Nunca permita a sabiendas que otra persona opere esta máquina con la capacidad de alerta o coordinación deteriorada.**

Un operador que toma un medicamento recetado o de venta libre debe consultar a un profesional médico con respecto a los efectos colaterales del medicamento que podrían reducir su capacidad de operar este equipo con seguridad.

Cumplimiento del programa de seguridad

Conozca las reglas

La mayoría de los empleadores tienen reglas que rigen la operación y el mantenimiento de los equipos. Antes de comenzar a trabajar en una ubicación nueva, verifique con el supervisor o con el coordinador de seguridad. Averigüe sobre las reglas que tendrá que obedecer.

La Administración de Seguridad y Salud Ocupacional (Occupational Safety and Health Administration, OSHA) hace cumplir leyes federales dentro de los EE.UU. que se aplican a la operación, la aplicación y el mantenimiento seguros de equipos en un sitio de trabajo. Es responsabilidad del empleador cumplir estas leyes. Un representante de OSHA puede visitar periódicamente un sitio de trabajo para ver si estas leyes se cumplen.

También puede haber leyes estatales/provinciales o locales u ordenanzas internacionales que se apliquen a este equipo y a su uso, junto con reglas específicas del sitio de trabajo o del empleador. Es importante que conozca y cumpla todas las leyes y reglas aplicables, incluso las que requieren capacitación y certificación del operador.

Las siguientes son algunas de las reglas que debe cumplir al trabajar:

- Un ROPS (sistema de protección antivuelco) y un tractor equipado con cinturón de seguridad es exigencia del

gobierno federal (OSHA) para la protección de los operadores durante el funcionamiento de la cortadora. Una cabina cerrada proporciona protección adicional para el operador con respecto a objetos arrojados. Verifique el manual del operador de la cortadora de césped para ver si también se requiere una cabina de tractor.

- Use y verifique que otras personas usen la indumentaria y los equipos de protección personal correctos.
- Inspeccione la máquina y los accesorios antes de cada uso según lo especificado por el fabricante y por su empleador.
- Conozca las limitaciones y las características operativas del equipo de corte de césped. No haga un uso indebido.
- Verifique que todos los escudos y las guardas estén correctamente instalados antes de hacer funcionar la máquina.
- Nunca modifique o retire partes de la máquina (excepto para realizar servicios; después, asegúrese de que se vuelvan a colocar en su lugar).

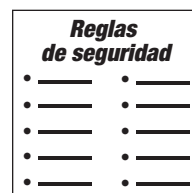

Sepa cuáles son y asegúrese de comprender las reglas de funcionamiento

Cumplimiento del programa de seguridad

Algunas reglas que debe cumplir al trabajar (continuación)

- Únicamente personas cualificadas y autorizadas pueden manejar estos equipos.
- **Nunca permita que los niños jueguen** en los equipos, **viajen** en ellos o los hagan **funcionar**. Los niños **no están** cualificados para manejar estos equipos.
- **No** transporte pasajeros.
- Use contacto en tres puntos (asideros y peldaños) y enfrente el equipo al ascender o descender de él.
- Mantenga a las personas ajenas a 300 pies (92 m) de la operación de corte.
- Familiarícese con el sitio de trabajo antes de usar la cortadora de césped. Tenga en cuenta posibles riesgos que puede encontrar en el terreno. Retire o marque los obstáculos y residuos que podrían dañar la cortadora o ser arrojados por ella.
- Utilice sólo accesorios y partes aprobados por el fabricante de la cortadora de césped.
- Asegúrese de que todos accesorios estén descendidos, aplique el freno de estacionamiento, apague el motor y haga funcionar todas las palancas de control. Retire la llave antes de salir del tractor. (Consulte la página 18, **Prácticas correctas de apagado de los equipos.**)
- Cuando transporte la cortadora de césped en un remolque, siga las instrucciones detalladas del fabricante para la carga, el amarre y la descarga de la cortadora.

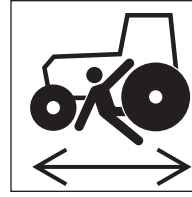

Mantenga a los niños alejados de los equipos



Mantenga a las personas ajenas alejadas



No lleve pasajeros

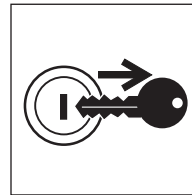

Apague los equipos cuando están sin vigilancia

Cumplimiento del programa de seguridad

Conozca los equipos

Lea y asegúrese de comprender los letreros de seguridad que indican PELIGRO, ADVERTENCIA, PRECAUCIÓN y AVISO y otros letreros informativos que hay sobre el tractor y la cortadora de césped y en el manual del operador del fabricante. Solicítele al supervisor o al distribuidor de la cortadora que le explique cualquier información que no comprenda. El incumplimiento de las instrucciones de seguridad podría resultar en lesiones graves o muerte.



Lea y asegúrese de comprender todos los letreros de seguridad

Asegúrese de que todas las estructuras de protección, guardas, escudos, pantallas y paneles del fabricante están bien reparados, en su lugar y bien ajustados. Los componentes de seguridad dañados, faltantes o debilitados pueden crear una situación de riesgo para usted como operador. **Nunca** retire o modifique ningún componente de seguridad (incluso escudos para objetos arrojados) que haya en la cortadora.

Conozca lo siguiente sobre el tractor y la cortadora de césped:

- Funcionamiento, propósito y uso de todos los controles.
- Velocidades de funcionamiento correctas.
- Capacidades y funcionamiento correcto en pendientes y terrenos desparejos.
- Características del frenado y la dirección.
- Radio de giro y separaciones.
- Cómo detener los equipos rápidamente en una emergencia.

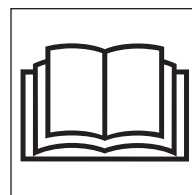

Lea y asegúrese de comprender los manuales antes de comenzar la operación

Preparación para una operación segura

Revise los equipos de la cortadora de césped y el tractor

Antes de comenzar la jornada de trabajo, inspeccione la máquina y asegúrese de que todos los sistemas estén en buenas condiciones operacionales.

¡ADVERTENCIA! Evite posibles lesiones por aplastamiento producidas por equipos que caen. La falla del sistema hidráulico o de una parte podría causar la caída de equipos que no están apoyados. **No permanezca debajo de equipos elevados excepto que estén correctamente apoyados de acuerdo con el manual del operador.**

- Realice procedimientos de servicio diarios y periódicos según lo indicado por el fabricante del equipo.
- Verifique para detectar piezas faltantes, dañadas, rotas o flojas en el tractor y en la cortadora de césped. Repare o sustituya esas piezas.
- Verifique que los accesorios del tractor y la cortadora sean los correctos.
- Verifique que la clasificación nominal de velocidad de TDF del tractor y la cortadora sea la correcta.
- Verifique el estado de las hojas de la cortadora de césped. Sustituya las hojas que se encuentren gravemente gastadas, dobladas, agujereadas o

- marcadas; incluya los pernos y sujetadores de las hojas. Nunca enderece o suelde en las hojas.
- Asegúrese de que el escudo para objetos que son arrojados se encuentre correctamente instalado y en buen estado. Repárelo o sustitúyalo si está dañado o falta.

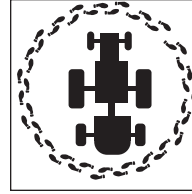

Recorrida de inspección

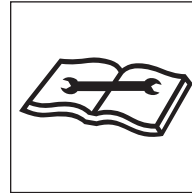

Realice el mantenimiento de la máquina

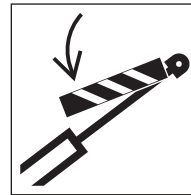

Lea el manual – Bloquee o apoye con seguridad la cortadora

Preparación para una operación segura

- Verifique que todos los escudos y guardas estén en su lugar y que todos los equipos se encuentren en buenas condiciones de funcionamiento. Esto incluye la línea motriz de la TDF, la caja de engranajes y las guardas y escudos de los implementos que se usan para proteger al operador.
- Verifique que los dispositivos de bloqueo del extremo en horquilla de la línea motriz estén correctamente enclavados.
- Verifique en busca de sistemas hidráulicos dañados o con fugas en el tractor o la cortadora. Repare o ajuste según sea necesario.

¡ADVERTENCIA! El fluido hidráulico bajo presión puede penetrar la piel o los ojos y causar lesiones graves, ceguera o la muerte. Las fugas de fluido bajo presión pueden no ser visibles. **Utilice un cartón o una madera para buscar fugas, no la mano. Use protección ocular.** Si el fluido se inyecta en la piel, debe ser extraído dentro de las próximas pocas horas por personal médico familiarizado con este tipo de lesión.

- Mantenga la superficie de la plataforma del operador limpia y libre de grasa, aceite, suciedad, nieve o hielo. Los peldaños y asideros deben estar limpios y funcionar correctamente.
- Asegúrese de que las luces de trabajo se mantengan limpias (si están instaladas). Verifique que todas las luces funcionen correctamente.

- Asegúrese de que el letrero de vehículo de movimiento lento, los y las luces de advertencia estén en buenas condiciones y puedan verse claramente.
- Asegúrese de que todas las herramientas y objetos sueltos se retiren o se sujeten con seguridad mientras se opera la máquina.
- Verifique que todos los letreros de seguridad se vean con claridad. Sustituya los letreros dañados.



Revise para detectar/guardas y escudos dañados



Verifique en busca de fugas e inspeccione las mangueras



Aparte las reflectores herramientas

Preparación para una operación segura

Familiarícese con la zona de trabajo

Antes de hacer funcionar la cortadora de césped, inspeccione cuidadosamente la zona de trabajo. Recorra a pie alrededor de la zona e inspeccione las superficies sobre las cuales se desplazará cuando utilice la cortadora.

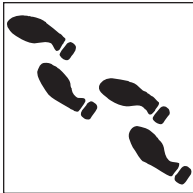

Recorra a pie alrededor del lugar de trabajo

Localice y evite:

- Agujeros
- Desmoronamientos
- Obstáculos (tocones)
- Excavaciones
- Agua estancada
- Lodo profundo
- Puntos mojados
- Suelo blando
- Puntos irregulares
- Líneas y aparatos eléctricos
- Otros servicios públicos
- Cualquier condición que podría causar una colisión, pérdida de control o vuelco
- Pendientes empinadas

Busque residuos y obstáculos recorriendo a pie la zona antes de cortar. Los objetos como alambre, cable, rocas, neumáticos y metales que podrían dañar o ser arrojados por la cortadora de césped deben retirarse o marcarse claramente y evitarse.

Corrija las condiciones no seguras. No opere en áreas con problemas donde no se puedan retirar o marcar los residuos y los obstáculos.

Analice la zona de corte para determinar:

- El procedimiento de corte más eficiente.
- La altura del material que debe cortarse.
- Las condiciones operativas del terreno.
- Cómo usar mejor el patrón de corte en sentido de avance.
- Las posibilidades de que personas ajenas o que pasan circunstancialmente queden expuestas a objetos que se arrojan.



Retire o marque los residuos y obstáculos

Tenga cuidado con otras personas

Antes de poner en marcha los equipos:

- Recorra a pie alrededor de los equipos.
- Verifique en busca de personas debajo o cerca de los equipos.
- Retire a todas las personas de esas zonas.
- Haga sonar una advertencia.

Preparación para una operación segura

Ascienda y descienda del tractor correctamente

Siempre use contacto de tres puntos al ascender o descender del tractor o de la cortadora de césped. Enfrente la máquina al ingresar o salir de ella. Un contacto de tres puntos significa que tres de los cuatro miembros (brazos y piernas) están en contacto con la máquina en todo momento durante el ascenso y descenso.

Antes de ascender:

- Límpiense el calzado y las manos. Limpie la nieve, el hielo, el lodo o el aceite de los peldaños y asideros.

Durante el ascenso y el descenso:

- Use los asideros y los estribos.
- Nunca se aferre al volante o a los controles como asideros.
- Nunca ascienda o descienda de un tractor en movimiento.
- Nunca ascienda o descienda transportando herramientas u objetos que impidan el contacto de tres puntos. Deje en el piso las piezas o las herramientas. Manteniendo el contacto correcto, suba y, después, recoja el objeto.



Utilice contacto de tres puntos



Limpie las superficies resbaladizas

Preparación para una operación segura

Prueba de seguridad de los controles del tractor y de la cortadora de césped

Arranque el tractor siguiendo los procedimientos específicos del manual del operador del fabricante. Estos procedimientos normalmente incluyen:

- Colóquese y ajústese el cinturón de seguridad en el tractor equipado con ROPS.
- Verifique que el freno de estacionamiento esté aplicado.
- Verifique que la TDF esté desenganchada.
- Verifique que todos los controles estén en la posición de estacionamiento.
- Advierta a otras personas en la zona antes de arrancar el tractor.
- Arranque el tractor siguiendo los procedimientos de arranque que recomienda el fabricante del tractor.

¡ADVERTENCIA! Evite lesiones graves o muertes producidas por el movimiento inesperado de la máquina. **Arranque el motor únicamente desde el puesto del operador. Nunca intente arrancar el motor haciendo un corto entre los bornes del arranque o tomando la llave desde el suelo o desde afuera de la cabina.**

Después del arranque:

- Verifique que todos los instrumentos, indicadores y luces indicadoras funcionen normalmente.
- Verifique que todos los controles, la dirección y los frenos del tractor funcionen correctamente.

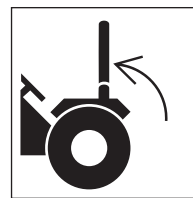

Use el ROPS y el cinturón de seguridad



Arranque únicamente desde el asiento del operador

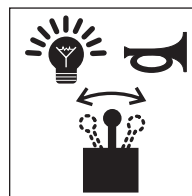

Revise los instrumentos y controles

- Eleve y descienda la cortadora de césped en busca de problemas en el descenso total o el enganche de la línea motriz.
- Verifique los equipos en busca de vibraciones excesivas y ruidos anormales.

Preparación para una operación segura

- Use las prácticas correctas de apagado de los equipos antes de inspeccionar equipos. Espere hasta que todo movimiento de los equipos se haya detenido antes de descender del tractor o la cortadora de césped.
- No haga funcionar la cortadora si el tractor y la cortadora de césped no funcionan correctamente. Coloque una etiqueta que indique “No poner en funcionamiento” en la máquina, retire la llave y no haga funcionar la cortadora hasta que el problema se haya corregido.

Sistema de toma de fuerza (TDF)

Asegúrese de hacer funcionar el tractor a la velocidad de TDF indicada para la cortadora.

Al hacer funcionar tractores con sistemas de TDF impulsados por transmisión, una cortadora giratoria tiene un significativo efecto de rueda volante. La cortadora puede seguir propulsando un tractor con un sistema de TDF impulsado por transmisión.

El tractor debe estar equipado y funcionar como sigue:

- Instale una línea motriz equipada con un embrague de sobrecarga.
- Prevea suficiente espacio y tiempo para maniobrar anticipando los giros, las paradas y las reducciones de velocidad.



No descienda hasta que el movimiento de los equipos se haya detenido



Use una etiqueta que indique “No poner en funcionamiento”

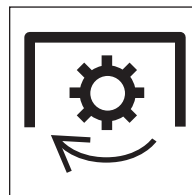

Use la velocidad de la TDF

Preparación para una operación segura

Enganche de la cortadora de césped al tractor

Cortadoras montadas en enganche de tres puntos:

- Consulte los manuales de los fabricantes de la cortadora y del tractor.
- Coloque la palanca selectora de elevación de potencia hidráulica del tractor en la posición descendida para evitar movimientos imprevistos.
- Explique los procedimientos de enganche a los operadores que no puedan leerlos.
- Pueden requerirse pesos en el extremo delantero para mantener el control de la dirección y la estabilidad del extremo delantero. Consulte los manuales del operador de los fabricantes.
- Al hacer retroceder el tractor hasta la cortadora de césped, NUNCA permita que haya personas entre tractor y la cortadora.
- Instale la cortadora en los eslabones de tres puntos del tractor y asegúrela en su lugar con pasadores.
- Instale con seguridad la línea motriz a la TDF del tractor. Descienda el escudo principal hasta su lugar si es móvil. Empuje y tire de la línea motriz para asegurarse de que esté trabada en el vástago de la TDF.

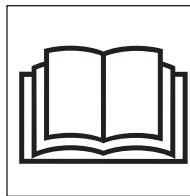

Lea y asegúrese de comprender los manuales antes de comenzar la operación



Mantenga una distribución correcta del peso



No permita que haya nadie entre el tractor y la cortadora de césped



Evite quedar enredado, use guardas y escudos

Preparación para una operación segura

Cortadoras montadas en enganche tipo de tiro:

- Consulte los manuales de los fabricantes de la cortadora y del tractor.
- Retire el acople rápido del enganche de tres puntos si está instalado.
- Instálelo únicamente al enganche de la barra de tiro.
- Ajuste la longitud de la barra de tiro del tractor para el funcionamiento de la TDF a 540 ó 1000 rpm.
- Al hacer retroceder el tractor hasta la cortadora de césped, NUNCA permita que haya personas entre tractor y la cortadora.
- Instale correctamente la cadena de remolque de seguridad de la cortadora en el tractor.
- Instale con seguridad la línea motriz a la TDF del tractor. Empuje y tire de la línea motriz para asegurarse de que esté trabada en la TDF. Descienda el escudo principal a su lugar.
- Conecte las mangueras hidráulicas de la cortadora de césped en el tractor.
- Asegúrese de que los laterales o las plataformas elevadas de la cortadora estén sostenidas por los cilindros antes de retirar las trabas de transporte. Nunca haga fuerza para soltar las trabas de transporte o de los laterales. Los laterales o la plataforma podrían caerse y aplastarlo.

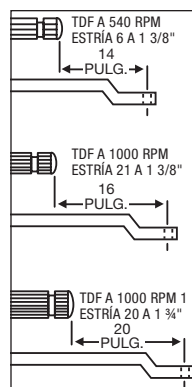

Ajuste de la barra de tiro del tractor



Confirme que los laterales estén apoyados antes de soltar las trabas



Evite quedar enredado, use guardas y escudos

Arranque con seguridad

Cómo realizar un arranque correcto

Corte la hierba únicamente con luz diurna o en condiciones de buena luz artificial.

Evite lesiones graves o muerte producidas por objetos arrojados por la cortadora o por el contacto con las hojas:

- Mantenga los escudos de las cadenas, los escudos deflectores flexibles o sólidos y las rampas de descarga en su lugar y en buen estado de reparación.
- Mantenga a las personas ajenas a 300 pies (92 m) de la operación de corte.
- Nunca dirija la descarga de la cortadora hacia una persona.
- Mantenga las manos, los pies y otras partes del cuerpo alejadas de las piezas giratorias, las hojas y las aberturas de descarga.
- No haga funcionar la cortadora de césped en la posición de transporte.

No se acerque a una cortadora hasta que todo movimiento se haya detenido.

Enganche de la transmisión de RDF de la cortadora de césped:

- Eleve la cortadora hasta la altura de corte máxima.
- Enganche la TDF a baja velocidad del motor.
- Aumente la velocidad del motor hasta llegar a la velocidad nominal de la TDF.
- Descienda la cortadora hasta la altura de corte deseada.
- Detenga y apague de inmediato si la cortadora golpea contra una obstrucción.
- Inspeccione y repare cualquier daño de la cortadora antes de reanudar el corte.
- No haga funcionar una cortadora que vibra en exceso o produce ruidos anormales.

Operación con seguridad

Los escudos de la cortadora están diseñados para reducir el riesgo de objetos arrojados y se deben mantener correctamente y en su lugar durante las operaciones de corte.

El riesgo de lesiones graves o muerte puede reducirse significativamente si se siguen estas reglas. **Si no se siguen todas estas reglas de seguridad, la operación de corte debe detenerse en caso de que alguna persona ingrese dentro del límite de seguridad correspondiente a cada tipo de cortadora.**

Primero — Inspeccione la zona antes de cortar y retire las piedras, ramas, alambres, cables, metales, vidrios y otros objetos sólidos antes de hacer funcionar la máquina. Los objetos que no puedan retirarse deben marcarse con claridad y ser evitados con cuidado por el operador.

En áreas sin cultivos con hierba y maleza de altura suficiente como para ocultar objetos que podrían ser golpeados por las hojas, inspeccione la zona y retire o marque los residuos u obstáculos grandes.



Hojas giratorias – Manténgase



No ponga en funcionamiento una cortadora de césped dañada

Objetos arrojados por la cortadora de césped

Dependiendo del propósito previsto, las cortadoras están diseñadas para cortar hierba, maleza, broza y cultivos. Las hojas de la cortadora están diseñadas y probadas para uso intensivo. Las hojas de la cortadora, sin embargo, no están diseñadas para entrar en contacto con objetos sólidos como rocas, cemento o metales. Un impacto de este tipo puede arrojar objetos rotos hasta 300 pies (92 m) de distancia. Nunca debe haber personas ajenas a menos de 300 pies (92 m) de una cortadora giratoria en funcionamiento o a menos de 100 pies (30 m) de una cortadora de disco correctamente equipada.



Siga todas las reglas de seguridad

Realice el corte de la zona a una altura intermedia. Inspeccione la zona atentamente y retire o marque cualquier residuo u obstáculo restante. Corte nuevamente a la altura final deseada.

Segundo — Los escudos para objetos arrojados por la cortadora deben usarse cuando se opera cerca de caminos, parques, zonas pobladas u otras zonas donde objetos arrojados podrían lesionar a personas ajenas o dañar la propiedad. Siga el manual del operador del fabricante.

Tercero — Cruce en sentido diagonal cuando realiza el corte a través de zanjas, depresiones marcadas y hundimientos. Eleve la cortadora para evitar que las hojas de la cortadora golpeen el suelo.

Operación con seguridad

Objetos arrojados por la cortadora de césped (continuación)

Cortadoras de disco — Cuando se usa una cortadora de disco, es importante conocer la zona donde se va a cortar. Si el operador ha realizado cortes en el terreno antes y está familiarizado con todos los obstáculos que puede haber, es suficiente observar delante de la trayectoria de la cortadora para detectar cualquier objeto adicional que pueda haber ingresado en el terreno. Está preparado para detenerse o evitar objetos que podrían ser peligrosos si son arrojados por la cortadora. Si piensa cortar en un terreno que no conoce bien y se encuentra junto a un camino transitado o puede haber personas a menos de 100 pies (30 m) de la cortadora de césped, debe inspeccionar y limpiar o marcar el terreno.

Cómo cortar en retroceso

No corte mientras se desplaza en retroceso. Es más probable que se arrojen objetos y que éstos puedan llegar más lejos.



No corte en retroceso

Apague la TDF, espere que las hojas dejen de girar, eleve la cortadora y, después, retroceda.

Corte desplazándose en sentido de avance.

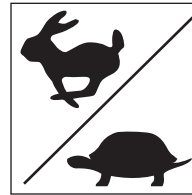

Use la velocidad de desplazamiento correcta

Velocidad de desplazamiento durante el corte

La velocidad de desplazamiento correcta depende de las condiciones del terreno y del tipo de hierba, la densidad y la altura que debe cortarse:

- El rango normal de velocidad de desplazamiento es de 2 a 5 mph (3.2 a 8 km/h).
- Use una velocidad de desplazamiento menor para cortar hierbas altas y densas.
- Use una velocidad de desplazamiento mayor para cortar hierba delgada a altura media y con condiciones de terreno sin dificultades.
- Use una velocidad de desplazamiento menor para acortar en terreno irregular, con pendientes o no muy conocido.

Las cortadoras de disco están diseñadas para usar velocidades de desplazamiento mayores cuando funcionan en terrenos despejados de residuos y peligros superficiales.

Operación con seguridad

Corte de hierba extremadamente alta

Puede ser necesario cortar dos veces la hierba extremadamente alta que no sea cultivo. (Consulte la página 13, **Objetos arrojados por la cortadora de césped.**)

Primera pasada de corte:

- Apague la cortadora y el tractor usando la práctica correcta de apagado de equipos antes de descender del tractor. (Consulte la página 18, **Prácticas correctas de apagado de los equipos.**)
- Inspeccione la zona y retire o marque cualquier residuo u obstáculo.
- Corte la hierba a mayor altura (10 a 15 pulg. [25 a 38 cm]) para evitar los objetos ocultos.

Segunda pasada de corte:

- Apague la cortadora y el tractor usando la práctica correcta de apagado de equipos antes de descender del tractor.
- Inspeccione la zona y retire o marque cualquier residuo u obstáculo.
- Corte la hierba a la altura deseada y, de ser posible, a 90 grados con respecto a la primera pasada de corte.

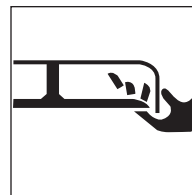

Detenga la hoja antes de desatascar

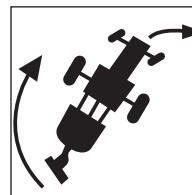

Proporcione el espacio libre adecuado para la oscilación de la cortadora de césped

Preste atención a los espacios libres de los equipos

Las cortadoras con enganche de tres puntos y montaje lateral tienen un arco de giro mayor que las tipo de tiro. Deje el espacio libre suficiente para la oscilación de la cortadora cuando gira.

No permita que haya personas ajenas cerca del tractor y la cortadora de césped cuando mueve o transporta el tractor y la cortadora.

Operación con seguridad

Prácticas de seguridad para la cortadora de césped de montaje inferior

Cuando se traslada con una cortadora de césped de montaje inferior:

- Mantenga la rampa de descarga extraíble en su lugar y por encima de la abertura de descarga.
- Nunca se pare sobre la carcasa de una cortadora de césped cuando el motor del tractor está en funcionamiento.
- Distribuya los recortes de hierba con la rampa de descarga orientada hacia la zona donde se cortó.
- Antes de limpiar una cortadora o una rampa de descarga atascada, apague la máquina usando la práctica correcta para apagado del equipo. (Consulte la página 18, **Prácticas correctas de apagado de los equipos.**)



Nunca se pare sobre la cortadora de césped – Manténgase alejado

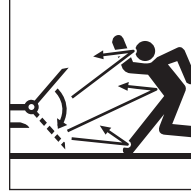

Mantenga la rampa en su lugar

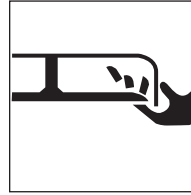

Detenga la hoja antes de desatascar

Operación con seguridad

Cortadora de césped con lateral o aguilón Peligros y riesgos de obstrucciones elevadas

Verifique en busca de obstrucciones elevadas con las cortadoras que tienen el lateral o el aguilón elevado, para evitar lesiones graves o la muerte por contacto con:

- Líneas y aparatos eléctricos.
- Ramas bajas de los árboles.
- Otras obstrucciones elevadas.
- Mantenga las distancias especificadas con respecto a los cables y los aparatos eléctricos. Nunca se acerque a cables o aparatos eléctricos energizados con ninguna parte de la máquina, salvo que se hayan tomado todas las precauciones de seguridad locales, estatales/provinciales y federales (OSHA) necesarias. Use extrema precaución.

¡PELIGRO! Evite la electrocución o lesiones graves por contacto o un espacio libre inadecuado con respecto a líneas o aparatos eléctricos energizados. **No permita que la máquina o el accesorio se acerque o entre en contacto con una línea de electricidad. No se acerque ni toque una máquina que esté en contacto con una línea de electricidad.**

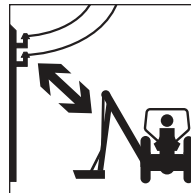

No se acerque a líneas de electricidad energizadas

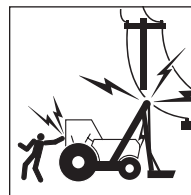

Manténgase alejado de los equipos energizados

Operación con seguridad

Prácticas de seguridad para cortadoras de césped con laterales y montaje lateral

Las posiciones elevadas de los laterales reducen la protección de los escudos y aumentan los riesgos de objetos arrojados y contacto con las hojas.

Evite la posibilidad de lesiones graves o muerte por objetos arrojados o contacto con las hojas causados por la elevación y el descenso de los laterales durante las operaciones de corte:

- No realice cortes con personas ajenas presentes a menos de 300 pies (92 m) de la cortadora de césped.
- Asegúrese de que no haya personas cerca de la cortadora mientras se elevan o descienden los laterales.
- Apague la TDF y espere hasta que todos los elementos giratorios se hayan detenido antes de elevar la plataforma o la sección lateral de la cortadora.
- Únicamente eleve el lateral para quitar objetos de la trayectoria de corte o para acompañar una pendiente del terreno.
- Descienda hasta el suelo el lateral elevado una vez que se eliminó el objeto o se superó la pendiente.
- Detenga el trabajo de corte si alguna persona se acerca a menos de 300 pies (92 m) de la zona de corte.

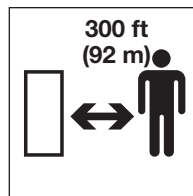

Mantenga a las personas ajenas alejadas de la zona de corte

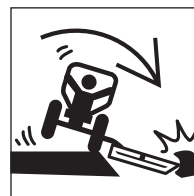

Evite golpear obstrucciones

Prácticas de seguridad para trabajos de corte en orillas de zanjas

Use extremo cuidado al realizar cortes en orillas de zanjas. Preste atención a escurrimientos, zonas erosionadas y obstrucciones para el corte a lo largo de las orillas de zanjas. Si se golpean obstrucciones con cortadoras de montaje lateral o con aguilón, el extremo delantero del tractor puede desviarse hacia la zanja.

Operación con seguridad

Los trabajos en orillas de zanjas con aguilón y lateral elevado pueden reducir la eficacia de la protección del operador de la cortadora que proporcionan los escudos para objetos arrojados.

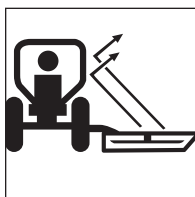

Utilice cabinas cerradas con ROPS o cerramientos de protección

- Cuando realice estas operaciones, use cabinas cerradas con ROPS, cerramientos protectores especiales y otros escudos para el operador que ofrece el fabricante.
- Inspeccione la zona de corte y retire o marque todos los objetos extraños y los residuos que deberá esquivar la cortadora.

Prácticas de seguridad para trabajos de corte en terrenos desparejos

Las pendientes y los terrenos desparejos reducen la estabilidad del tractor y de la cortadora.

Como en todas las condiciones de corte, use tractores equipados con ROPS y cinturón de seguridad. **Asegúrese**

de que el ROPS está elevado y trabado en su lugar y use siempre el cinturón de seguridad.

Prevenga los vuelcos del tractor y de la cortadora de césped y mantenga controlada la estabilidad de los equipos:

- Repase los manuales del operador del tractor y de la cortadora para ver las prácticas de seguridad para operaciones en pendientes y terrenos desparejos. Explique las prácticas a los operadores que no puedan leerlas.
- Evite trabajar en pendientes extremadamente empinadas.

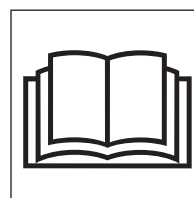

Lea y asegúrese de comprender los manuales antes de comenzar la operación

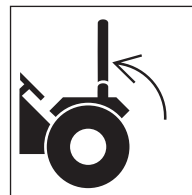
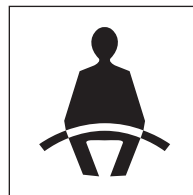

Use el ROPS y el cinturón de seguridad

Operación con seguridad

Prácticas de seguridad para trabajos de corte en terrenos desparejos (continuación)

- Use extremo cuidado para mantener el control de los equipos cuando trabaja en estas condiciones.
- Aumente la estabilidad del tractor agregando pesos o lastre en las ruedas y aumentando al máximo la separación entre las ruedas. Consulte las recomendaciones en el manual del operador.
- Mantenga la velocidad de desplazamiento en el mínimo.
- Realice giros amplios y graduales.
- Evite los arranques, las paradas y los giros bruscos cuando trabaje en subidas o bajadas de pendientes o sobre ellas.
- **No** levante del suelo las cortadoras de montaje trasero o de montaje lateral ni los laterales de la cortadora durante estas operaciones.
- Manténganse alerta en busca de agujeros, baches, pozos, tocones u otras obstrucciones que podrían hacer volcar la máquina.
- Evite las condiciones de suelo resbaladizo que podrían causar la pérdida de control y el vuelco del tractor y la cortadora.
- Evite bajar completamente y golpear el suelo cuando cruza en sentido diagonal depresiones marcadas y hundimientos.

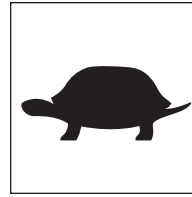

Mantenga el control, desplácese



Agregue lastre, ensanche la separación entre las ruedas



Evite los pozos, baches y agujeros

Use extremo cuidado al mantener la estabilidad de los equipos durante todos los trabajos de corte en terrenos desparejos y pendientes. Usted es quien juzga en última instancia si en cualquier pendiente se puede trabajar con seguridad.

Operación con seguridad

Prácticas de seguridad para el transporte en caminos

Antes de operar en la vía pública:

- Consulte los manuales del operador de los fabricantes de la cortadora y del tractor para ver instrucciones.
- Explique las instrucciones a los usuarios u operadores que no puedan leerlas.
- Verifique las ordenanzas locales sobre marcas, luces, balizas, etc. requeridas en los equipos durante el desplazamiento por la vía pública. Se requieren luces en las cortadoras que obstaculizan la visibilidad de las luces traseras y/o las luces de advertencia del tractor.
- Cuando transporte la cortadora de césped en un remolque, siga las instrucciones detalladas del fabricante para la carga, el amarre y la descarga de la cortadora.

Antes de transportar en la vía pública:

- Desconecte la alimentación de la TDF a la cortadora.
- Eleve la cortadora a la posición de transporte y aplique la traba para transporte.
- Trabe los laterales de la cortadora de césped en la posición de transporte con dispositivos de bloqueo aprobados.
- Instale una cadena de seguridad para remolque entre la cortadora tipo de tiro y el tractor.
- Asegúrese de que las luces, las luces de advertencia y los reflectores están en su lugar y son visibles.

- Verifique que el emblema de vehículo de movimiento le resulte visible a cualquier vehículo que se aproxime por atrás.

Durante el transporte en la vía pública:

- Obedezca todas las ordenanzas de tránsito locales.
- Acérquese a las intersecciones con precaución.
- Observe los letreros de velocidad y control del tránsito.
- Evite las paradas de emergencia y los giros cerrados.

Sea un operador amable y apártese periódicamente para dejar pasar el tránsito.

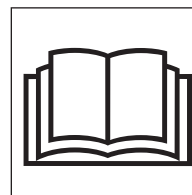

Lea y asegúrese de comprender los manuales antes de comenzar la operación



Obedezca las ordenanzas de tránsito

Estacionamiento seguro

Prácticas de seguridad para el estacionamiento

- Use las zonas designadas o alejadas del tránsito.
- Use lugares con suelo firme y nivelado.
- Aplique el freno de estacionamiento.
- Descienda el equipo de la cortadora de césped hasta el suelo.

Apague la cortadora y el tractor usando la práctica correcta de apagado de equipos antes de descender del tractor. (Consulte la página 18, **Prácticas correctas de apagado de los equipos.**)

Lugares de estacionamiento con suelo en pendiente:

- Ubique los equipos transversalmente con respecto a la pendiente.
- Aplique los frenos de estacionamiento.
- Descienda el equipo de la cortadora de césped hasta el suelo.
- Bloquee las ruedas del tractor.



Aplique el freno de estacionamiento

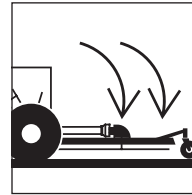

Descienda los equipos elevados hasta el suelo

Antes de estacionar temporalmente y dejar equipos deshabilitados cerca de zonas con tránsito:

- Retire los equipos de la vía pública.
- Instale banderas de advertencia.
- Use las balizas de advertencia del tractor.

Apagado con seguridad

Prácticas correctas de apagado de los equipos

Transforme el apagado correcto de los equipos en un hábito.

El apagado correcto de un tractor y una cortadora de césped puede ayudar a evitar accidentes cuando la cortadora está sin vigilancia. Apague la cortadora siguiendo los procedimientos específicos del manual del operador del fabricante. Estos procedimientos normalmente incluirán:

- Reduzca la velocidad del motor.
- Desenganche el embrague de la TDF y la transmisión.
- Haga funcionar el motor en ralentí para que se enfríe gradualmente.
- Coloque todos los controles en la posición de estacionamiento.
- Aplique el freno de estacionamiento.
- Descienda la cortadora de césped hasta el suelo.
- Descienda los laterales de las cortadoras con laterales hasta el suelo.
- Apague el motor, trabe la ignición y retire la llave de la máquina; llévela con usted.
- Espere hasta que todas las piezas móviles se hayan detenido antes de descender.
- Libere la presión hidráulica moviendo los controles hidráulicos varias veces en todas las direcciones.
- Trabe las cubiertas y los cerramientos antivandalismo, si están instalados, cuando los equipos están sin vigilancia.
- Descienda con cuidado manteniendo contacto de tres puntos.

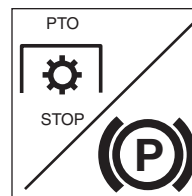

Desenganche la TDF, aplique el freno

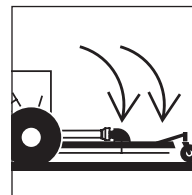

Descienda los equipos elevados hasta el suelo



Espere hasta que las piezas giratorias se detengan

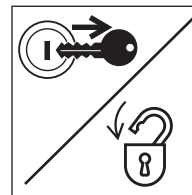

Retire la llave, trabe la ignición, llévese la llave

Apagado con seguridad

Descenso correcto

- Nunca descienda de equipos en movimiento.
- Nunca baje de una máquina saltando.
- Descienda con cuidado.
- Verifique que no haya peldaños resbaladizos.
- Mantenga los pies y las manos lejos de los controles.
- Use los asideros y los peldaños durante el descenso.
- Enfrente la máquina y use contacto de tres puntos (2 manos y 1 pie o 2 pies y 1 mano).



Espere hasta que las piezas móviles se detengan



Use contacto de tres puntos; enfrente a la máquina

Realización de mantenimiento con seguridad

Mantenimiento de los equipos

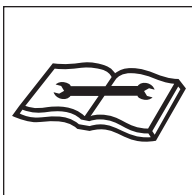

Realice el mantenimiento de los equipos

Asegúrese de mantener los equipos de acuerdo con las instrucciones del fabricante. Verifique con regularidad el funcionamiento de los dispositivos de protección y de seguridad.

No realice ningún trabajo en un tractor o en una cortadora de césped si no está autorizado y cualificado para hacerlo.

Si ha sido autorizado para realizar mantenimiento, **lea los manuales del operador y de servicios**. Estudie las instrucciones; verifique las tablas de lubricación; examine todos los mensajes de instrucciones que haya sobre la máquina. El mantenimiento puede ser peligroso si no se realiza correctamente. Asegúrese de tener las habilidades necesarias, la información y las herramientas y equipos correctos para realizar el trabajo.

¡ADVERTENCIA! No modifique equipos ni agregue componentes no aprobados por el fabricante. Use piezas, lubricantes y técnicas de servicio recomendadas por el fabricante.

Piezas de la cortadora de césped y seguridad personal

Los fabricantes de cortadoras de césped usan sujetadores y específicos y piezas especialmente diseñadas para cumplir con los requisitos de las operaciones de las cortadoras. Las piezas críticas (pernos autobloqueantes de las hojas, hojas, pasadores, escudos y otros componentes especiales) tienen requisitos específicos de resistencia, diseño y ajuste para la marca y el modelo de cortadora que usted está usando.

Evite posibles lesiones graves o la muerte por el uso de piezas o modificaciones no aprobadas:

- No sustituya con tornillería común los pernos de las hojas u otros componentes de piezas especiales originales del fabricante.
- No sustituya hojas, pasadores, escudos u otras piezas críticas.
- No use pernos de mayor resistencia para reemplazar los pernos de seguridad originales del fabricante.

Realización de mantenimiento con seguridad

Preparación personal

Use la ropa de protección personal y los equipos de protección personal (PPE) que se le proporcionen o que requieran las condiciones del trabajo. **SIEMPRE** debe usar gafas de seguridad con escudos laterales.

Puede necesitar también:

- Casco
- Calzado de seguridad
- Anteojos de seguridad, antiparras o protección facial
- Delantal y guantes
- Protección para oídos
- Casco o antiparras para soldar
- Respirador o máscara con filtro

Use la ropa necesaria; no corra ningún riesgo.

Mantenga las manos (y la ropa) alejadas de todas las piezas móviles. No use cordones sueltos, mangas flojas, anillos, relojes o cabello largo.

¡ADVERTENCIA! Evite lesiones graves o muerte por enredos. **No use ropa floja ni accesorios. Manténgase alejado de todos los componentes giratorios cuando el motor está en funcionamiento.** El contacto, el enrollado o el enredo con piezas giratorias o móviles podrían resultar en lesiones graves o la muerte.

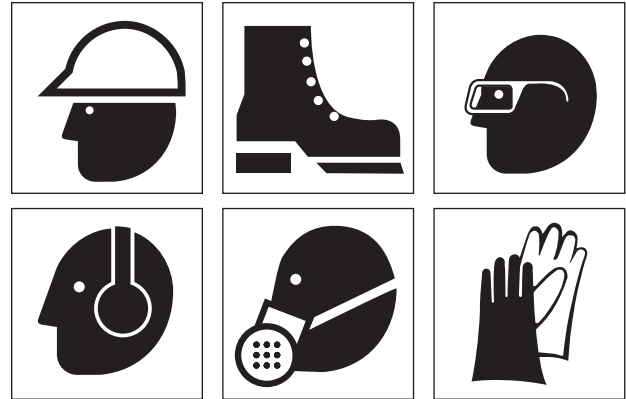

Evite las piezas giratorias



Evite puntos donde pueda quedar atrapado

Realización de mantenimiento con seguridad

Use un delantal de caucho y guantes de caucho cuando trabaja con sustancias corrosivas. Use guantes y calzado de seguridad cuando manipula bloques de madera o metales con bordes agudos.

Use siempre anteojos de seguridad, antiparras o protección facial. Proporcionan protección ocular para fluidos bajo presión, mientras se esmerila y se realizan servicios a las baterías. También es necesaria protección contra residuos, líquidos y material suelto producido por el equipo, las herramientas y el aire/agua presurizada.

Use protección facial y siga las instrucciones del fabricante cuando desarma componentes cargados a resorte o cuando trabaja con ácidos de batería. Use un casco o antiparras para soldar con filtro esfumado cuando suelda o corta con soplete.

No arene, esmerile, corte con soplete o suelde sin un respirador aprobado por NIOSH o una ventilación adecuada. Si se requiere soldar en esta máquina, consulte los manuales del operador o de servicios del fabricante o consulte al concesionario de los equipos para obtener los procedimientos correctos.

Mantenga los bolsillos sin objetos que podrían salirse y caer dentro de la maquinaria.



Limpie las superficies resbaladizas

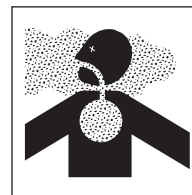

Ventile la zona de trabajo

Maneje las herramientas y las piezas pesadas con sensatez con respecto a usted mismo y a otras personas. Deposite los elementos, no los deje caer.

Preparación de la zona de trabajo

- Ubique la cortadora de césped en una zona nivelada fuera del paso de otros equipos en funcionamiento.
- Asegúrese de que haya luz, ventilación y espacio libre adecuados.
- Quite el aceite, la grasa o el agua para eliminar toda superficie resbaladiza.
- Limpie alrededor de la zona donde se realizarán servicios para minimizar la contaminación.

Realización de mantenimiento con seguridad

Preparación de la máquina

Deben controlarse o reducirse las fuentes de energía almacenada (eléctricas, mecánicas, hidráulicas, neumáticas, químicas, térmicas, etc.) al mínimo practicable antes de realizar cualquier procedimiento de mantenimiento, reparación o servicio.

Prácticas de seguridad para prevenir posibles lesiones por fuentes que liberan energía:

- Desenganche la TDF antes de apagar el motor.
- Coloque los controles en la posición de estacionamiento o punto muerto antes de apagar el motor.
- Aplique el freno de estacionamiento o bloquee las ruedas.
- Espere hasta que todas las piezas móviles se detengan.
- Descienda la cortadora de césped hasta el suelo.
- Descienda los laterales de las cortadoras con laterales hasta el suelo.
- Apague el motor del tractor.
- Libere la presión del sistema hidráulico moviendo los controles varias veces en todas las direcciones.
- Trabe la ignición, retire la llave y llévesela.



Prepare los sistemas de la máquina para realizarles servicios

- Escuche y observe en busca de evidencias que indiquen piezas en movimiento antes de descender.
- Apoye o bloquee con seguridad la cortadora de césped antes de trabajar debajo de ella o de otros componentes elevados.
- Apoye, bloquee o trabe con seguridad los laterales de la cortadora con dispositivos de traba aprobados antes de trabajar cerca o debajo de una cortadora con laterales.
- Alivie la presión antes de desconectar o desarmar un sistema presurizado.
- Bloquee o alivie la presión de los resortes antes de desarmar un mecanismo cargado a resorte.
- Apoye o bloquee con seguridad cualquier componente elevado de la máquina antes de trabajar en él.
- Evite las llamas, las chispas y no fume cerca de combustibles, fluido hidráulico u otro material inflamable como los residuos de los cortes.

Realización de mantenimiento con seguridad

Fije una etiqueta con la advertencia “NO PONER EN FUNCIONAMIENTO” en todas las palancas de control y retire la llave de contacto si la cortadora de césped no debe ser utilizada. Llévese la llave.

Instale dispositivos de apoyo aprobados cuando trabaja debajo o cerca de equipos elevados.

¡ADVERTENCIA! Las cortadoras de césped u otros equipos elevados no apoyados pueden caerse de manera imprevista. **Nunca se introduzca debajo de equipos elevados si no están apoyados en dispositivos de apoyo aprobados.** La caída de equipos podría resultar en una lesión grave o la muerte por aplastamiento.

Retire sólo las guardas o cubiertas que permiten acceder a la zona donde se realizarán servicios. Vuelva a colocar todas las guardas y cubiertas cuando el trabajo esté terminado.



Use una “etiqueta que indique No poner en funcionamiento”

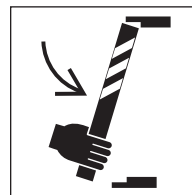

Utilice dispositivos de apoyo aprobados



Vuelva a colocar todas las guardas

Realización de mantenimiento con seguridad

Use ventilación adecuada

Si es necesario hacer funcionar un motor en una zona cerrada, elimine del área las emanaciones de escape con una extensión del caño de escape. Si no tiene esa extensión, asegúrese de abrir las puertas y dejar entrar aire del exterior.

¡ADVERTENCIA! Evite posibles lesiones. **Nunca trabaje en la maquinaria con el motor en funcionamiento salvo que así lo indiquen los manuales del fabricante para un servicio en particular.**

¡ADVERTENCIA! **Nunca haga funcionar ningún tipo de motor sin la ventilación adecuada: LAS EMANACIONES DEL ESCAPE PUEDEN SER MORTALES.**

Use gatos y malacates con cuidado

Los soportes o bloques de seguridad deben ubicarse en una parte rígida de la cortadora. No ubique soportes debajo de ejes o apoyos de ruedas que puedan girar.

Si debe trabajar debajo de equipos elevados, siempre use bloques de madera (**no de concreto**), soportes de gato u otros soportes rígidos y estables. Cuando use gatos o malacates, siempre asegúrese de que están correctamente apoyados.

¡ADVERTENCIA! Evite posibles lesiones por aplastamiento. **Nunca use bloques de concreto para apoyo.** Pueden colapsar bajo cargas incluso livianas.

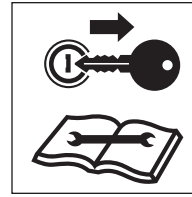

Retire la llave y lea el manual de mantenimiento



Ventile la zona de trabajo



Use un apoyo adecuado para los equipos elevados

Asegúrese de que los malacates o gatos que usa estén en buenas condiciones. Nunca use gatos con piezas rajadas, dobladas o retorcidas. Nunca use cables pelados, retorcidos o pellizcados. Nunca use ganchos doblados o deformados.

Realización de mantenimiento con seguridad

Prácticas de seguridad para tareas de mantenimiento comunes

Riesgos del combustible

¡ADVERTENCIA! Siempre use recipientes y/o equipos de distribución de combustible aprobados.

Los combustibles son inflamables; por eso, debe cumplir estas prácticas con el fin de reducir la posibilidad de un accidente grave.

- Apague el motor y la ignición mientras carga combustible.
- Siempre conecte a tierra la boquilla de combustible contra el cuello de llenado del depósito para evitar chispas.
- Mantenga las chispas y llamas abiertas alejadas del combustible.
- No fume mientras carga combustible o manipula recipientes con combustible.
- No corte ni suelde en líneas, tanques o recipientes de combustible ni cerca de ellos.
- No llene el depósito en exceso o derrame combustible. Limpie el combustible derramado de inmediato.

Riesgos del refrigerante de motor

Los sistemas de refrigeración con líquidos acumulan presión a medida que el motor se calienta; **tenga suma precaución antes de retirar la tapa del radiador.**

Asegúrese de:

- Detener el motor y esperar que el sistema se enfríe.
- Usar ropa de protección y anteojos de seguridad.
- Girar la tapa del radiador lentamente hasta el primer tope para permitir que la presión escape antes de retirar la tapa por completo.



No fumar; evitar las llamas abiertas



Retire la tapa del radiador lentamente

Realización de mantenimiento con seguridad

Riesgos del sistema hidráulico

El sistema hidráulico se encuentra bajo presión siempre que el motor está funcionando; puede conservar presión incluso después de apagar el motor. Haga funcionar todos los controles hidráulicos incluyendo el control hidráulico auxiliar después de que el motor esté apagado. Alivie la presión atrapada en las líneas después de que los accesorios están apagados y apoyados en el suelo.

Durante la inspección del sistema hidráulico:

- Espere que el fluido se enfríe antes de desconectar las líneas. El fluido hidráulico caliente puede causar QUEMADURAS GRAVES.
- **No** use las manos para verificar la presencia de fugas. En cambio, use un cartón o papel para buscar fugas.
- Use protección ocular adecuada. El fluido hidráulico puede causar lesiones oculares permanentes.

¡ADVERTENCIA! El fluido hidráulico bajo presión pueden penetrar la piel o los ojos y causar lesiones graves, ceguera o la muerte. Las fugas de fluido bajo presión pueden no ser visibles. **Utilice un cartón o una madera para buscar fugas, no la mano. Use una protección facial o antiparras de seguridad para proteger los ojos.** Si el fluido se inyecta en la piel, debe ser extraído dentro de las próximas pocas horas por personal médico familiarizado con este tipo de lesión.

Cuando ventila o llena el sistema hidráulico, afloje la tapa de llenado con lentitud y retírela gradualmente.

Nunca restablezca una válvula de alivio del sistema hidráulico a una presión mayor que la recomendada por el fabricante.

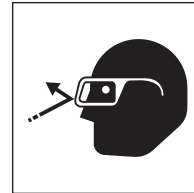

Use protección ocular



El fluido a alta presión puede inyectarse en el cuerpo

Realización de mantenimiento con seguridad

Riesgos del sistema eléctrico

Antes de trabajar en el sistema eléctrico, desconecte los cables de la batería.

- Retire primero los cables negativos (-) de la batería.
- Al reconectar la batería, conecte los cables negativos (-) de la batería al final.

El líquido del interior de las baterías contiene ácido, que es un VENENO y puede causar QUEMADURAS QUÍMICAS GRAVES.

Evite lesiones

- Use una protección facial para evitar el contacto con los ojos.
- Use guantes y ropa resistentes a los productos químicos para mantener al electrolito alejado de la piel y la ropa común.

¡ADVERTENCIA! El contacto con el electrolito daña los ojos y la piel. **Siempre use una protección facial para evitar que el electrolito penetre en los ojos.** Si el electrolito entra en contacto con los ojos, enjuague de inmediato con agua limpia y busque atención médica.

Use guantes de caucho y ropa de protección para mantener el electrolito lejos de la piel. Si el electrolito entra en contacto con la piel o la ropa, lave de inmediato con agua limpia.

Si se ingiere, busque atención médica de inmediato. **NUNCA** proporcione líquidos que induzcan el vómito.

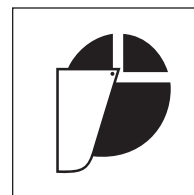

Use protección facial

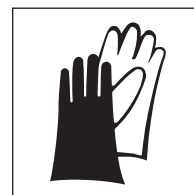

Use indumentaria de protección

Realización de mantenimiento con seguridad

Evite explosiones

¡ADVERTENCIA! Evite posibles lesiones graves por explosiones. Las baterías de plomo-ácido producen gases sumamente explosivos, especialmente durante la carga. **Mantenga alejados los arcos, las chispas, las llamas y el tabaco encendido.**

- No fume cerca de las baterías.
- Mantenga los arcos, las chispas y llamas abiertas alejadas de las baterías.
- Proporcione ventilación adecuada.

Nunca revise la batería colocando un objeto metálico entre los bornes: la chispa resultante podría causar una explosión.

¡ADVERTENCIA! Evite posibles lesiones graves por explosiones de baterías. **No cargue baterías ni arranque con refuerzo el motor si la batería está congelada.** Caliente a 60 °F (15,5 °C) o la batería puede explotar y causar lesiones graves.

Reglas de seguridad durante el arranque con refuerzo de batería:

- Siga las instrucciones para el “arranque con refuerzo de batería” correcto como se especifica en el manual del fabricante.

- Asegúrese de que las máquinas no se estén tocando.
- Observe la polaridad de las baterías y conexiones.
- Realice la conexión final de cable al motor o al punto de tierra más alejado de la batería. Nunca realice la conexión final en el arrancador o la batería muerta: las chispas pueden encender gases explosivos presentes en la batería.
- Cuando desconecta cables después de un arranque con puente, retire los cables en el orden inverso al de la conexión (es decir, la conexión final primero).

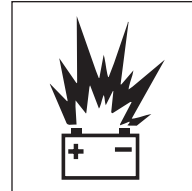

Evite las chispas y las llamas abiertas cerca de las baterías

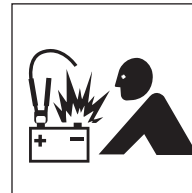

Para el arranque con refuerzo, observe la polaridad y realice la conexión final en el punto de descarga a tierra

Realización de mantenimiento con seguridad

Mantenimiento de neumáticos y ruedas

Revise los neumáticos y las ruedas a diario porque la estabilidad del tractor y la cortadora de césped puede verse significativamente afectada por la presión de los neumáticos o daños en los neumáticos o en las ruedas.

Revise los neumáticos para verificar:

- La presión correcta.
- Cortes y protuberancias.
- Clavos u otras pinchaduras.
- Desgaste desparejo o excesivo.
- Estado de los vástagos y tapas de las válvulas.

Revise las ruedas para verificar:

- Daños en las llantas.
- Tuercas o pernos faltantes o flojos.
- Desalineación.

Todos los servicios de neumáticos deben ser realizados por un centro de servicios para neumáticos cualificado o por una persona de servicio autorizada debidamente capacitada en los procedimientos y el uso del equipo de seguridad destinado a los servicios de neumáticos.

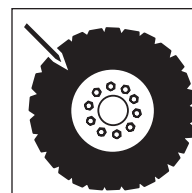

Revise los neumáticos y las ruedas en busca de daños

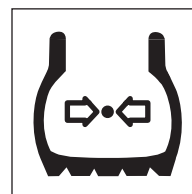

Mantenga la presión correcta en los neumáticos

Realización de mantenimiento con seguridad

Mantenimiento de neumáticos y ruedas (continuación)

¡ADVERTENCIA! Los tipos de ruedas y neumáticos que generalmente se encuentran en estos equipos requieren cuidados especiales al realizar servicios para evitar lesiones graves o la muerte.

No infle los neumáticos por encima de la presión recomendada. Asegúrese de volver a colocar el lastre de los neumáticos si está instalado. Consulte las especificaciones del fabricante para ver los requisitos de lastre.

Mantenga las tuercas de las ruedas apretadas según las recomendaciones del fabricante.

Es normal que la presión de los neumáticos aumente durante el funcionamiento; NO se debe reducir.

Nunca vuelva a inflar un neumático que se ha desinflado mucho o por completo sin retirar el neumático de la rueda. Haga inspeccionar atentamente el neumático y la rueda para detectar daños antes de volverlos a armar.

Al agregar aire a un neumático, hágalo desde cierta distancia. Use una manguera larga con mandril de autofijación. Siempre párese detrás de la trocha cuando ajusta la presión de un neumático.

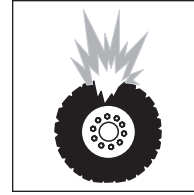

Evite la explosión de los neumáticos

No infle neumáticos con gases inflamables o con sistemas que usan un inyector de alcohol.

Nunca corte o suelde una rueda con un neumático inflado instalado en ella. Esto podría causar descompresión explosiva.

Verifique que el tamaño del neumático y la rueda coincidan correctamente.

Cuando reemplaza neumáticos, asegúrese de que sean de la clasificación adecuada especificada por el fabricante.

Los neumáticos no deben funcionar a velocidades más altas que las nominales. La mayoría de los neumáticos para agricultura están clasificados para una velocidad máxima de 20 mph (32 km/h).

Realización de mantenimiento con seguridad

Servicio y reparaciones completas antes de liberar la máquina

Apriete todos los pernos, accesorios y conexiones con las torsiones especificadas por el fabricante.

Instale todas las guardas, cubiertas y escudos después de realizar los servicios. Reemplace o repare los que estén dañados. Llene y recargue los sistemas a presión sólo con los fluidos aprobados o recomendados por el fabricante.

Arranque el motor y revise para detectar fugas. (Consulte la página 23, **Riesgos del sistema hidráulico**.) Haga funcionar todos los controles para asegurarse de que el tractor y la cortadora de césped funcionan correctamente. Pruebe la máquina si es necesario. Después de las pruebas, apague y verifique el trabajo realizado. ¿Falta algún pasador, arandela, tuerca de seguridad, etc.? Vuelva a revisar todos los niveles de fluidos antes de liberar la máquina para el funcionamiento.

Todas las piezas deben ser inspeccionadas durante la reparación y deben reemplazarse si están gastadas, rajadas o dañadas. Las piezas excesivamente gastadas o dañadas pueden fallar y causar lesiones o la muerte.

Reemplace cualquier letrero dañado o ilegible.



Verifique el trabajo de servicio cuando está completo

Mantenimiento de las hojas de la cortadora

No corra riesgos usando hojas dañadas o dobladas. Los fabricantes de cortadoras de césped de la Asociación de Fabricantes de Equipos (Association of Equipment Manufacturers, AEM) y la Asociación de Fabricantes de Equipos para Agricultura (Farm Equipment Manufacturers Association, FEMA) piden que las hojas de cortadoras NO se reutilicen, enderecen, refuercen en su superficie o suelden. Si una hoja rota es arrojada por una cortadora, podrían producirse lesiones graves o la muerte.

Realización de mantenimiento con seguridad

Mantenimiento de las hojas de la cortadora (continuación)

- **¿Cómo están hechas las hojas de la cortadora de césped?** Están hechas acero para resortes de aleación de alta resistencia. Se forjan en caliente y se les da forma para cumplir con las especificaciones individuales del fabricante; luego, se tratan y templean a un estado dúctil, de alta resistencia para reducir la posibilidad de rupturas durante el corte. Las hojas se prueban para garantizar que cumplan con las normas de resistencia, dureza y ductilidad. Si una hoja no cumple con alguna de estas especificaciones, no se utilizará en la cortadora de césped.
- **¿Qué sucede cuando se dobla una hoja de la cortadora?** Se necesita una gran fuerza de impacto para doblar la hoja. Esta fuerza de impacto a menudo resulta en que las hojas se agujerean o marcan. Una vez que una hoja está dañada por un agujero o una marca, es mucho más probable que ocurra una falla de la hoja. Cuando una hoja está gravemente doblada, puede crearse una rajadura microscópica en ella. Enderezar la hoja no quita o repara esta rajadura, sino que puede causar rajaduras adicionales. Tensiones adicionales durante los trabajos de corte pueden resultar en una falla imprevista de la hoja.
- **Evite doblar las hojas.** Contribuya a prevenir que las hojas de la cortadora se doblen o rajen evitando el contacto con objetos sólidos. Las hojas de la cortadora de césped están destinadas a cortar hierba, arbustos, vegetación leñosa y árboles y ramas pequeños. No están diseñadas para entrar en contacto con objetos sólidos como roca, cemento o postes de acero. Inspeccione la zona antes de usar la cortadora. Retire o marque claramente los objetos sólidos y corte alrededor de ellos.
- **Sustituya las hojas dañadas!** Inspeccione las hojas de la cortadora diariamente o después de golpear algún objeto sólido. Si una hoja de la cortadora de césped se daña (está doblada, agujereada, rajada) o desgasta más del 25 por ciento del tamaño original, debe retirarse y sustituirse con una nueva. Siempre use las hojas originales del fabricante. Las hojas de marcas no originales pueden no cumplir con los requisitos de resistencia, dureza y ductilidad del fabricante de la cortadora.
- **No corra riesgos usando hojas dañadas o dobladas.** El uso de una hoja de cortadora dañada o enderezada puede resultar en la ruptura de la hoja y que la hoja sea arrojada hacia el operador o una persona ajena causando una lesión grave o la muerte. El precio de una nueva hoja es bajo en comparación con la posibilidad de una lesión grave que podría resultar de una hoja doblada o rota arrojada por la cortadora

Palabras finales para el usuario

Acaba de terminar de leer el Manual de la cortadora de césped industrial y para agricultura AEM. Es imposible que este manual abarque todas las situaciones de seguridad que se podría encontrar a diario. Su conocimiento de estas precauciones de seguridad y de su cumplimiento de las reglas básicas de seguridad

contribuirán a formar un buen juicio en todas las situaciones. Nuestro objetivo es ayudarlo a desarrollar, establecer y mantener buenos hábitos de seguridad para que la operación de una cortadora de césped industrial y para agricultura le resulte más fácil y más segura.

Éste es otro manual de una serie publicada por AEM sobre la operación de maquinaria en condiciones de seguridad. Muchas de las ilustraciones de este manual de seguridad se pueden encontrar y descargar en <http://pictorials.aem.org>. Para obtener publicaciones adicionales, visite nuestro sitio web en www.safetymaterials.org.



ASOCIACIÓN DE FABRICANTES
DE EQUIPOS

Correo electrónico: safetymaterials@aem.org
www.aem.org

INTRODUCTION SECTION

Introduction Section 2-1

INTRODUCTION

This Flail Mower is designed with care and built with quality materials by skilled workers. Proper assembly, maintenance, and operating practices, as described in this manual, will help the owner/operator get years of satisfactory service from the machine.

The purpose of this manual is to familiarize, instruct, and train. The Assembly Section instructs the owner/operator in the correct assembly of the Mower using standard and optional equipment. The Parts Manual is designed to familiarize the owner/operator with replaceable parts on the Mower and is provided also. This section provides exploded assembly drawings of each mower component illustrating each piece and the corresponding part number.

Careful use and timely service saves extensive repairs and costly downtime losses. The Operation and Maintenance Sections of the manual train the owner/operator how to work the Mower correctly and attend to appropriate maintenance. The Trouble Shooting Guide helps diagnose difficulties with mower and offers solution to the problems.

Safety is of primary importance to the owner/operator and to the manufacturer. The first section of this manual includes a list of Safety Messages, that, if followed, will help protect the operator and bystanders from injury or death. Many of the Safety Messages will be repeated throughout the manual. The owner/operator/dealer should know these Safety Messages before assembly and be aware of the hazards of operating this mower during assembly, use, and maintenance. The Safety Alert Symbol combined with a Signal Word, as seen below, is intended to warn the owner/operator of impending hazards and the degree of possible injury faced when operating this machine.



Indicates an imminently hazardous situation that, if not avoided, WILL result in DEATH OR VERY SERIOUS INJURY.



Indicates an imminently hazardous situation that, if not avoided, COULD result in DEATH OR SERIOUS INJURY.



Indicates an imminently hazardous situation that, if not avoided, MAY result in MINOR INJURY.

Important

Identifies special instructions or procedures that, if not strictly observed, could result in damage to, or destruction of the machine, attachments or the environment.

INTRODUCTION



1. Rear Mower
2. Wing Mower
3. Frame
4. Rubber Deflector
5. Hydraulic Hoses
6. Hydraulic Cylinders
7. Motor
8. Hydraulic Tank
9. Drive Belt
10. Driveline
11. Gearbox

INTRODUCTION

The Interstate is a revolutionary mowing system. Utilizing 2 side wings and 1 rear, you have ability to mow up to 20' across in on swath. Perfect for large areas of mowing including interstate highways and airport fields. A productive way to get a manicured cut in spaces there is high public visibility.

Unique in-frame cooling system maintains the proper oil temperature while providing constant power flow.

Strong top decks make with 10-gauge steel and end plates that are 1/2" thick for the inboard and 5/16" thick steel for the outboard.

Smart front mount hydraulic pump that drives power from the crankshaft of tractor, while twin piston pumps provide the power for the wing mowing units.

Knife Variety - An array of cutting knife options allows you to tailor the finished appearance to meet your needs.

Cutting Capacity: 1" diameter grass and weeds.

Wing Cutting Widths:

20' 9" Interstate, 88" Rear Flail, 88" Left and Right Wings

18' 5" Interstate, 88" Rear Flail, 74" Left and Right Wings

16' 5" Interstate, 88" Rear Flail, 60" Left and Right Wings

13' 2" Single-Side Interstate, 88" Rear Flail and 88" Right Wing

12' 2" Single-Side Interstate, 88" Rear Flail and 74" Right Wing

Literature Page



www.algqr.com/ale

INTRODUCTION

INTRODUCTION

Attention Owner/Operator

BEFORE OPERATING THIS MACHINE:

1. Carefully read the Operator's Manual, completely understand the Safety Messages and instructions, and know how to operate correctly both the tractor and implement.
2. Fill out the Warranty Card in full. Be sure to answer all questions, including the Serial Number of the implement. Mail within 30 days of delivery date of this implement.

NOTE: Warranties are honored only if completed "Owner Registration and Warranty" forms are received by Alamo Group within thirty days of delivery of the implement.

3. Record the Model and Serial Numbers on the Warranty page at the front of the Operator's Manual. Keep this as part of the permanent maintenance file for the implement.

! WARNING

Non-genuine parts can fail catastrophically. TO AVOID SERIOUS INJURY OR DEATH:

- ONLY use genuine ALAMO INDUSTRIAL replacement parts.
- Non-genuine parts can fail creating hazardous conditions for operator and bystanders.

Contact local dealer or ALAMO INDUSTRIAL about repair parts at: www.algqr.com/apm
1502 E. Walnut, Seguin, TX 78155.
Customer Service: 800-882-5762.
Email: support@alamo-industrial.com



IMPORTANT

BE AWARE BE ALERT BE ALIVE	BE TRAINED Before Operating this Mower
-------------------------------------------	---------------------------------------------------

To prevent serious injury to yourself and/or bystanders, be trained in Safe Mowing Practices. Alamo Group Companies as well as AEM and FEMA provide training material that is critical for your Safety and the Safety of others when operating this equipment. Make these Safety Procedures an important part of every workday. Read and understand the Operator's Manual. Do not let untrained individuals operate this equipment. Contact your Dealer, AEM (www.aem.org), FEMA (314-878-2304, www.FarmEquip.org), or Alamo Group (www.Alamo-Group.com) for information on training material or courses that provide training in Safer Operating Practices for Mowers.



www.algqr.com/ave

D816

INTRODUCTION

ALAMO-INDUSTRIAL LIMITED WARRANTY

1. LIMITED WARRANTIES

- 1.01. Alamo Industrial warrants for one year from the purchase date to the original non-commercial, governmental, or municipal purchaser ("Purchaser") and warrants for six months to the original commercial or industrial purchaser ("Purchaser") that the goods purchased are free from defects in material or workmanship.
- 1.02. Manufacturer will replace for the Purchaser any part or parts found, upon examination at one of its factories, to be defective under normal use and service due to defects in material or workmanship.
- 1.03. This limited warranty does not apply to any part of the goods which has been subjected to improper or abnormal use, negligence, alteration, modification, or accident, damaged due to lack of maintenance or use of wrong fuel, oil, or lubricants, or which has served its normal life. This limited warranty does not apply to any part of any internal combustion engine, or expendable items such as blades, shields, guards, or pneumatic tires except as specifically found in your Operator's Manual.
- 1.04. Except as provided herein, no employee, agent, Dealer, or other person is authorized to give any warranties of any nature on behalf of Manufacturer.

2. REMEDIES AND PROCEDURES.

- 2.01. This limited warranty is not effective unless the Purchaser returns the Registration and Warranty Form to Manufacturer within 30 days of purchase.
- 2.02. Purchaser claims must be made in writing to the Authorized Dealer ("Dealer") from whom Purchaser purchased the goods or an approved Authorized Dealer ("Dealer") within 30 days after Purchaser learns of the facts on which the claim is based.
- 2.03. Purchaser is responsible for returning the goods in question to the Dealer.
- 2.04. If after examining the goods and/or parts in question, Manufacturer finds them to be defective under normal use and service due to defects in material or workmanship, Manufacturer will:
 - (a) Repair or replace the defective goods or part(s) or
 - (b) Reimburse Purchaser for the cost of the part(s) and reasonable labor charges (as determined by Manufacturer) if Purchaser paid for the repair and/or replacement prior to the final determination of applicability of the warranty by Manufacturer.

The choice of remedy shall belong to Manufacturer.

- 2.05. Purchaser is responsible for any labor charges exceeding a reasonable amount as determined by Manufacturer and for returning the goods to the Dealer, whether or not the claim is approved. Purchaser is responsible for the transportation cost for the goods or part(s) from the Dealer to the designated factory.

3. LIMITATION OF LIABILITY.

- 3.01. MANUFACTURER DISCLAIMS ANY EXPRESS (EXCEPT AS SET FORTH HEREIN) AND IMPLIED WARRANTIES WITH RESPECT TO THE GOODS INCLUDING, BUT NOT LIMITED TO, MERCHANTABILITY AND FITNESS FOR A PARTICULAR PURPOSE.
- 3.02. MANUFACTURER MAKES NO WARRANTY AS TO THE DESIGN, CAPABILITY, CAPACITY, OR SUITABILITY FOR USE OF THE GOODS.
- 3.03. EXCEPT AS PROVIDED HEREIN, MANUFACTURER SHALL HAVE NO LIABILITY OR RESPONSIBILITY TO PURCHASER OR ANY OTHER PERSON OR ENTITY WITH RESPECT TO ANY LIABILITY, LOSS, OR DAMAGE CAUSED OR ALLEGED TO BE CAUSED DIRECTLY OR INDIRECTLY BY THE GOODS INCLUDING, BUT NOT LIMITED TO, ANY INDIRECT, SPECIAL, CONSEQUENTIAL, OR INCIDENTAL DAMAGES RESULTING FROM THE USE OR OPERATION OF THE GOODS OR ANY BREACH OF THIS WARRANTY. NOTWITHSTANDING THE ABOVE LIMITATIONS AND WARRANTIES, MANUFACTURER'S LIABILITY HEREUNDER FOR DAMAGES INCURRED BY PURCHASER OR OTHERS SHALL NOT EXCEED THE PRICE OF THE GOODS.
- 3.04. NO ACTION ARISING OUT OF ANY CLAIMED BREACH OF THIS WARRANTY OR TRANSACTIONS UNDER THIS WARRANTY MAY BE BROUGHT MORE THAN TWO (2) YEARS AFTER THE CAUSE OF ACTION HAS OCCURRED.

4. MISCELLANEOUS.

- 4.01. Proper Venue for any lawsuits arising from or related to this limited warranty shall be only in Guadalupe County, Texas.
- 4.02. Manufacturer may waive compliance with any of the terms of this limited warranty, but no waiver of any terms shall be deemed to be a waiver of any other term.
- 4.03. If any provision of this limited warranty shall violate any applicable law and is held to be unenforceable, then the invalidity of such provision shall not invalidate any other provisions herein.
- 4.04. Applicable law may provide rights and benefits to purchaser in addition to those provided herein.

KEEP FOR YOUR RECORDS

ATTENTION: Purchaser should fill in the blanks below for his reference when buying repair parts and/or for proper machine identification when applying for warranty.

Alamo Industrial Implement Model _____ Serial Number _____

Date Purchased _____ Dealer _____

ATTENTION:

READ YOUR OPERATOR'S MANUAL

ALAMO INDUSTRIAL
An Alamo Group Company
Post Office Drawer 549
Seguin, Texas 78156
830-379-1480



INTERSTATER 10/18

Introduction Section 2-5

ASSEMBLY SECTION

Assembly Section 3-1

ASSEMBLY

GENERAL INSTRUCTIONS

To assemble your new INTERSTATER and mount it to your tractor we assist you with drawings, instructions and information, also about experiences of others and when needed just get some information or clarification from our engineering department over the phone.

These instructions are general information and not specifically for your tractor, but in connection with our drawings, they might offer you some valuable assistance.

This section covers the installation procedure of an Alamo Group Interstater mower kit, and includes parts lists for framework, hoses, and miscellaneous parts to be attached to your tractor.

These instructions are for mounting the center mower, right side mower, and left side mower units. For mounting one mower side only, disregard information concerning the opposite side. Hardware quantities shown are for both sides.

1. The hydraulic system must be kept "SURGICALLY CLEAN" to ensure proper operation and long life of the pumps, motors, and valves. All components have protective caps over openings connected to internal spaces to prevent contamination. It is important that care be taken during unpacking, assembly, and other contaminants which will damage parts.
2. After the drive belts are installed, DO NOT start the tractor unless the hydraulic system is filled with hydraulic oil. Running without oil will damage the pumps.
3. Check the oil level in the reservoir before start-up.
4. Care should be taken when filling the reservoir to prevent contamination of the hydraulic system. Always use new hydraulic fluid when filling the system. USE ONLY TRACTOR HYDRAULIC OIL IN THE HYDRAULIC SYSTEM. Reference to the left or right side of the Interstater is determined while facing the front of the tractor from the drivers seat.

Reference to the left or right side of the Interstater is determined while facing the front of the tractor from the drivers seat.

Assemble the Interstater, step by step, as illustrated on the pages of this section. Small parts (bolts, nuts, etc.) required are packed in numbered plastic bags which correspond to assembly procedures and illustrations in the manual.

The part quantities listed for an illustration pertain only to that phase of assembly. The quantity given corresponds to the number of parts needed. When assembling a single-sided model based on a dual-sided model, the quantity furnished will usually be half the quantity listed.

Large parts are not always listed next to an illustration because they are usually easy to identify.

Whenever reference is made to parts, listed for an illustration or elsewhere in this manual, the following abbreviations are used:

HHCS - hex head capscrew	RH - right hand	NF - national fine
LW - lock washer	LH - left	MA - mechanical assembly
PW- plain washer	NC - national coarse	WA - welded assembly

When installing fasteners, PW and LW (generally installed in that order) are usually on the side of the fixture or part being fastened that the hex/lock nut is on. When only HHCS, LW and/or PW are required, they are generally installed in that order. Some parts do not require a PW or LW. Refer to illustrations for exceptions. Fasteners should be installed so they cause the least interference with other parts. When securing driveshaft pulley to hub, tighten fasteners to 9 lb-ft torque.

This manual makes reference to individual component parts, some of which may have been pre assembled at the factory.

ASSEMBLY

PRELIMINARY TRACTOR PREPARATION

Depending on the make and model of tractor the INTERSTATER is to be mounted on, certain modifications will be illustrated. In some cases special accessory components for the tractor will be required before assembling the INTERSTATER. In these cases, specific mention will be made to the manufacturer, part number and description of required accessory component.

If so equipped, remove drawbar from rear of tractor. In most cases, the main frame rear pad is attached under the rear axle.

If so equipped, remove all objects from exterior of cab (lights, hand rails, etc.) which may interfere with mowers when placed in the transport position. Remove all objects from right front interior of cab structure which may interfere with mounting and operation of sectional control valve.

If so equipped, remove foot step from each side of tractor to which a mower will be mounted.

Front tractor wheels may require a wider adjustment to clear hydraulic tank and tank mounting frame.

SPECIAL TOOLS

Special tools, for installing and servicing INTERSTATER kits, are illustrated on the below. Drawings for these tools are available on request. If desired, tools may be obtained from Alamo on a made to order basis. Prices will be furnished on request. **ASM-FL-0001**

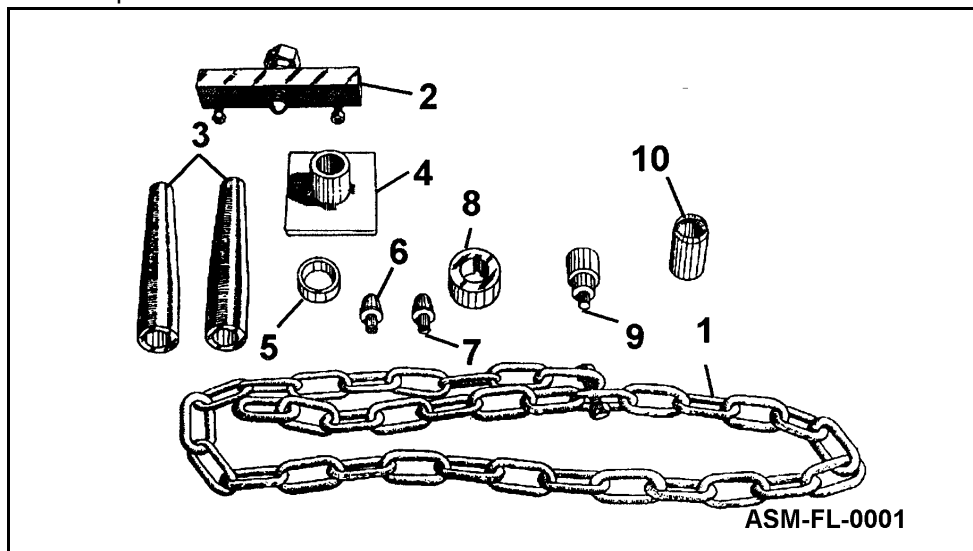

ITEM	PART NO.	CODE	DESCRIPTION
1	701628	S	Lift Frame Assembly Suspension Chain
2	701627	A	Cuttershaft Bearing Puller
3	104764	A	Lift Frame Alignment Pin (2)
4	104768	A	Rubber bushing Support Base
5	104767	A	Rubber Bushing Compression Ring
6	104765	A	Rubber Bushing Expander (Ford and Kubota Tractors)
7	104766	A	Rubber Bushing Expander (I.H., Massey-Ferguson and Case Tractors)
8	104769	A	Driveshaft Installation Collar
9	1047770	A	Rubber Bushing Installation Plug
10	103741	A	Seal Installation and Setting Tool
-	000802	S	Hydraulic Pressure Gauge, 3000 PSI

A - Denotes Special Tools designed by Alamo

S - Denotes Standard Tools or Equipment available on the market

ASSEMBLY

DRIVE COUPLING ATTACHMENT

Assemble the front coupling to the engine crankshaft pulley using the hardware supplied with the coupling. Due to the variations in the tractor models, it may be necessary to remove some of the sheet metal to facilitate mounting of the coupling. **ASM-FL-0002.**

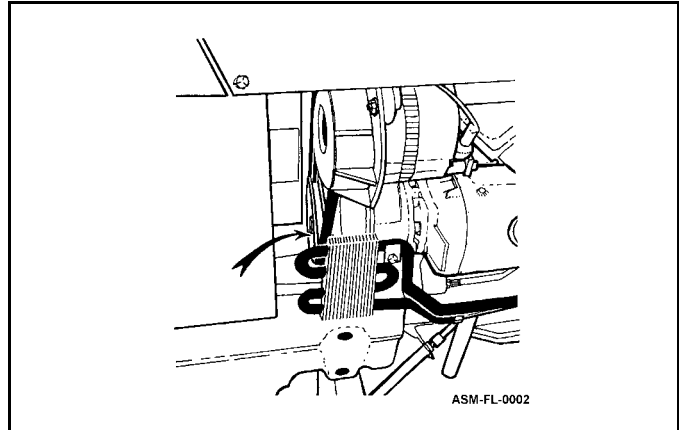

HYDRAULIC TANK, SUPPORTS AND MAINFRAME ATTACHMENT

1. Attach the left hydraulic tank support and step weldment to the tractor with (4) bolts provided in your Mount Kit. Refer to your particular Tractor Installation Drawing for part numbers and quantities. **ASM-FL-0003**
2. Attach the right hydraulic tank support to the tractor with (4) bolts provided in your Mount Kit. Refer to your particular Tractor Installation Drawing for part numbers and quantities. **ASM-FL-0004**
3. To make assembly easier, the hard plumbing assembly should be installed on the Mainframe before the Mainframe is installed. Use (2) 1/2" x 1-1/2" bolts, (2) 1/2" Flatwashers, and (2) 1/2" Locknuts. Metal tubing on assembly will need to be loosened to install bolts.

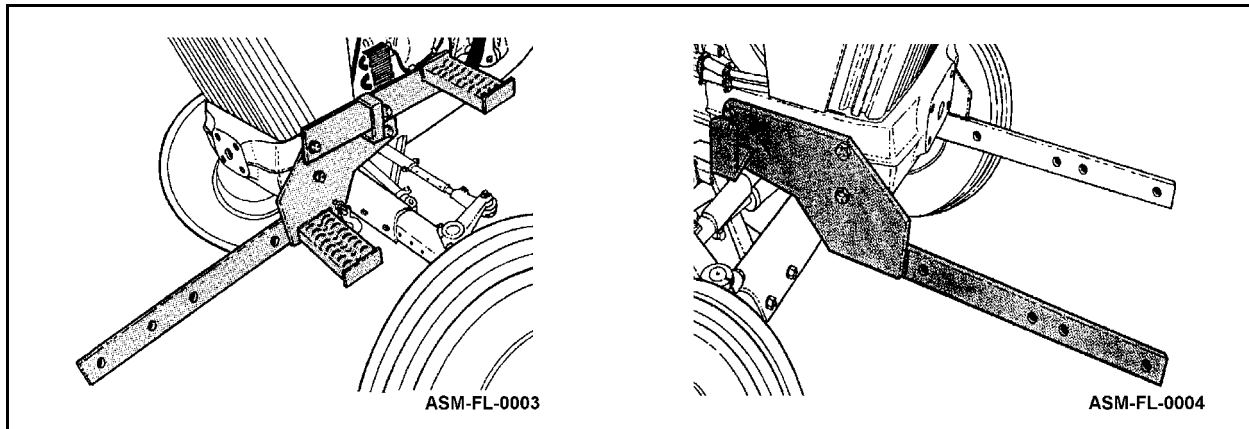

4. Position the mainframe under the tractor. Lift the front of the frame and install the top two 5/8" x 2" bolts. Install a 5/8" flatwasher and a 5/8" locknut on the bolts and tighten enough to hold the frame in place. **ASM-FL-0005**

ASSEMBLY

5. Lift the rear of the frame and secure with (4) 1/2" x 1 1/2" & (2) 5/8" x 1/3/4" bolts. Install the remaining front hardware. **ASM-FL-0006**

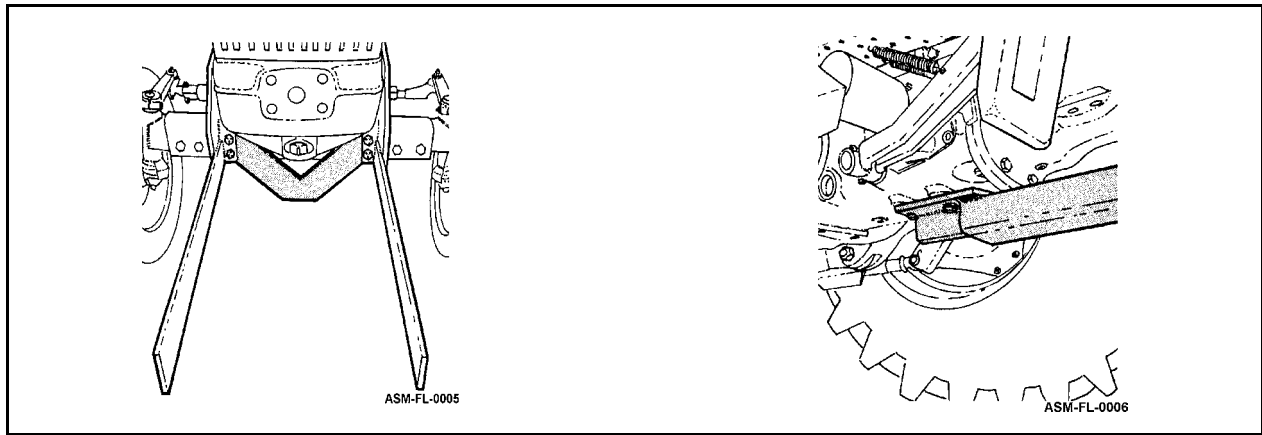

MOUNTING AND PUMP ASSEMBLY

1. Before mounting tank, attach pipe manifold for return lines to the return filter assembly.
2. Raise bumper with a forklift or hoist and lower onto hydraulic tank supports. Attach the bumper to the tank supports with (4) 1/2" x 2" bolts and (4) 1/2" locknuts. **ASM-FL-0007**
3. Now tighten all hardware for mainframe, tank support, tank, and bumper.

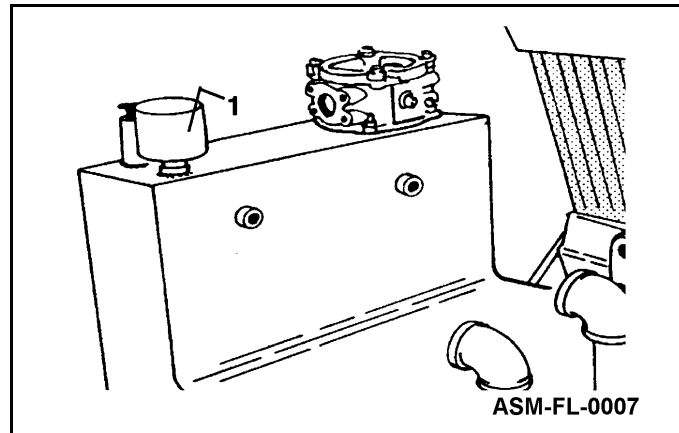

LIFT CYLINDER FRAME ATTACHMENT

Position the right and left lift cylinder supports and loosely install the (6) 3/4" x 2-1/4" bolts and (6) 3/4" locknuts to each side. Pull the supports outward and downward to remove the slack, then tighten the hardware. **ASM-FL-0008**

NOTE: On some applications Cylinder Support will have an extra set of holes. Refer to Installation Drawing for correct mounting.

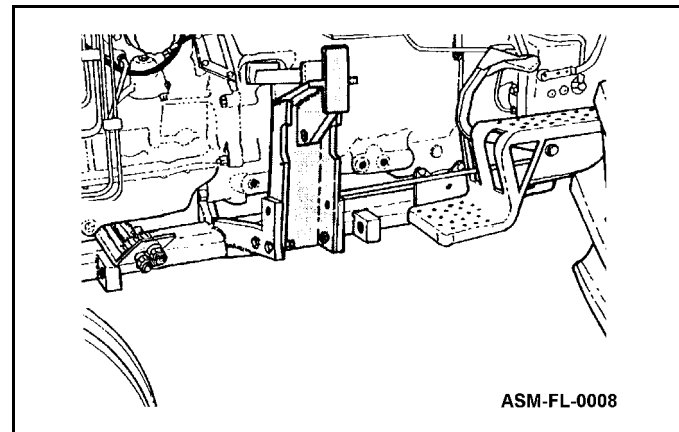

ASSEMBLY

Raise the left lift frame with the hydraulic jack and align frame with ears on main frame. **ASM-FL-0009**. Insert the upper pivot pins with the lift frame ears on the outside of the mainframe ears. Secure the pins with the (2) 3/8"x3/4" NF bolts and (2) 3/8" lockwashers. **NOTE: Use Locktight® on bolts.** **ASM-FL-0010**. Repeat procedure for right side.

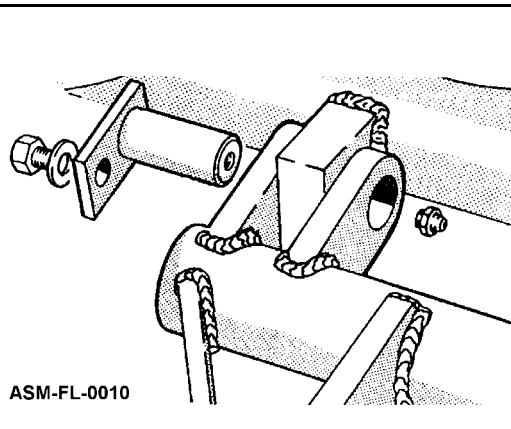
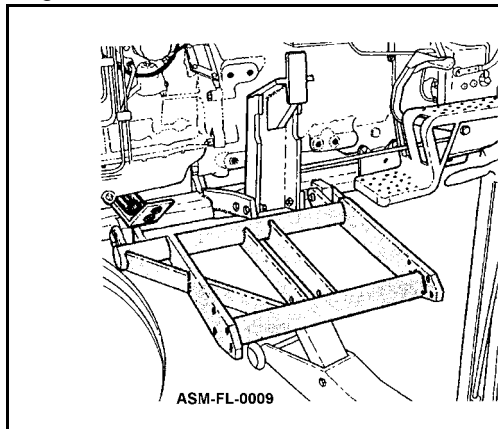

Mount the tilt and lift cylinders. The lift cylinder has a 3" bore diameter and the tilt cylinder has a 3-1/2" bore diameter. Be sure to remove the port caps before extending the cylinders. Attach with (2) cylinder pins and (2) 3/16" x 1-1/2" cotter pins to each side. **ASM-FL-0011**.

NOTE: Mount cylinder so that hose connections do not interfere when wings are raised and lowered.

For tractors equipped with a cab, a collar may need to be installed on the lift cylinder rod for proper alignment of the transport lock. Remove the cylinder end and the locking collar. Install the extra collar onto the rod and reassemble. **ASM-FL-0011**.

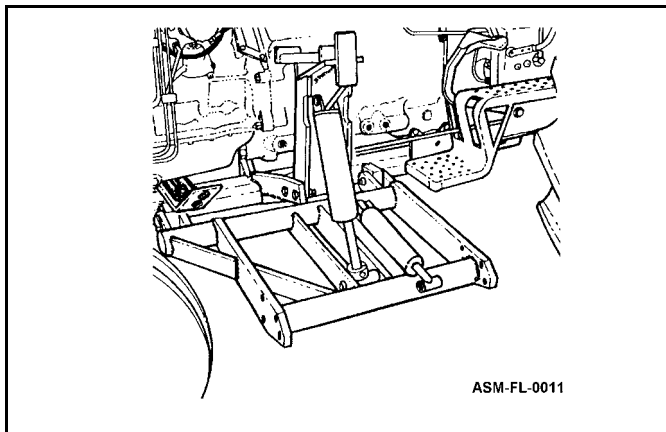

MOUNTING WING MOWERS

Assemble Skid Shoes on Cutter before mounting the head. With the cutter housing tipped up, attach housing shoes/wear plate. Carriage bolt attaches to front mounting hole; plow bolts attach to middle and rear holes. **ASM-FL-0012**

Position the cutter unit so that the outer pivots can be assembled over the pivot pins. Attach the front outer pivot to the lift frame using (4) 5/8 x 2-1/2 bolts and (4) 5/8 locknuts.

Attach switch assembly and rear outer pivot to the lift frame using (2) 5/8 x 3-1/2 bolts and (2) 5/8 locknuts. Install spacer (P/N 107242) between switch assembly and lift arm. **ASM-FL-0013**

Attach magnet assembly to picot pin using bolts and lockwashers provided. **ASM-FL-0014**.

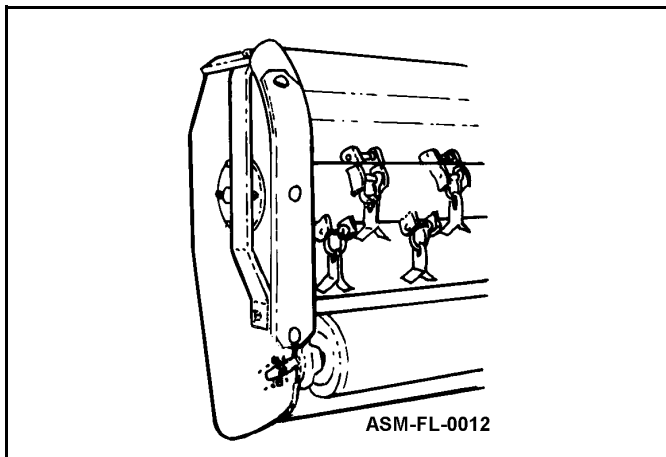

ASSEMBLY

CAUTION

If it is necessary to loosen the nut on the pivot pin. Re-torque the nut to 400 ft lbs. Failure to do so will cause the nut to loosen during use, allowing the pin to come out, thereby causing certain machine damage.

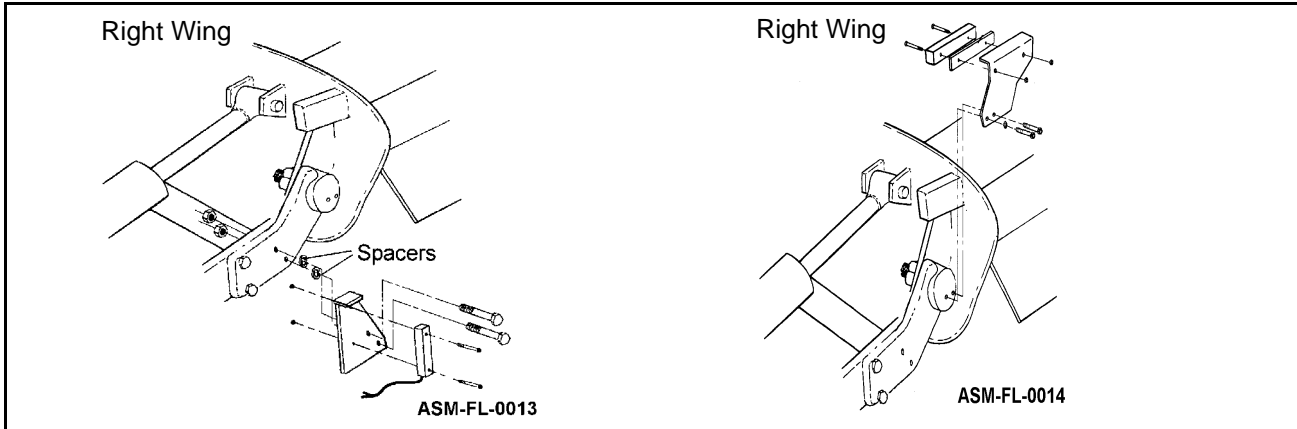

Remove belt guard. Assemble the rod end of the tilt cylinder. Use the pin located in the ears on the end of the housing and secure with the cotter pins. Reinstall belt guard.

Attach the air breather (Item 1) to the hydraulic tank. **ASM-FL-0015**

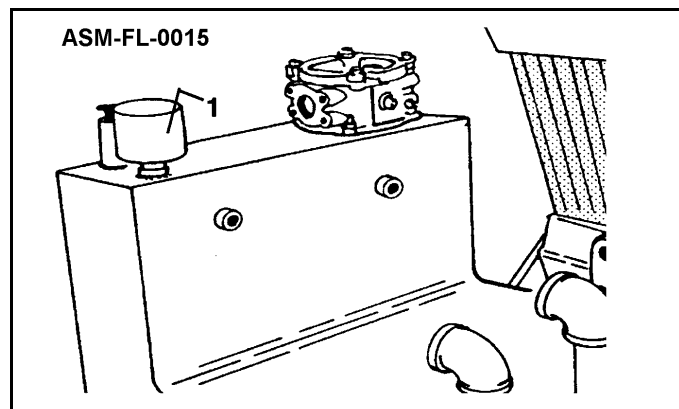

Insert driveshaft through the pump mount weldment until it slides into the crank shaft pulley coupling. When using auxiliary hydraulic pump, place the pump drive belt around driveshaft. Place splined pulley weldment on the driveshaft. **ASM-FL-0016**
NOTE: All splines on driveshaft and pump should have anti-seize applied.

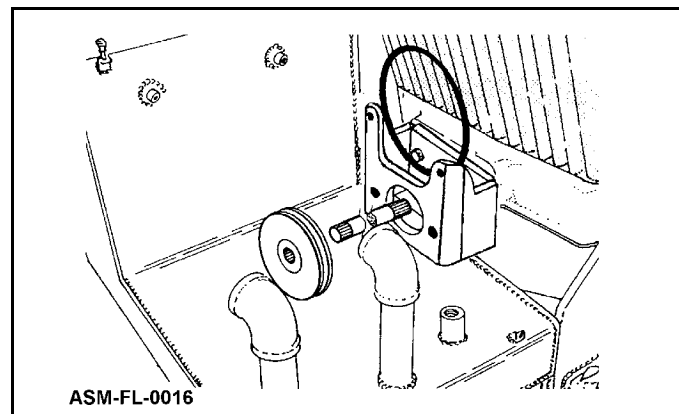

ASSEMBLY

ASSEMBLY

ASSEMBLY

Attach the hydraulic pump assemblies to the pump mount plate with (2) 1/2"x1-1/2" Grade 8 bolts and (2) 1/2" lockwashers. **ASM-FL-0017**

Attach pivot plate to pump mount weldment with (2) 1/2"x1-1/2" bolts, (2) 1/2" flatwashers and (2) 1/2" locknuts. Wrap belt around pulleys, adjust tension and tighten all bolts securely. **ASM-FL-0018.**

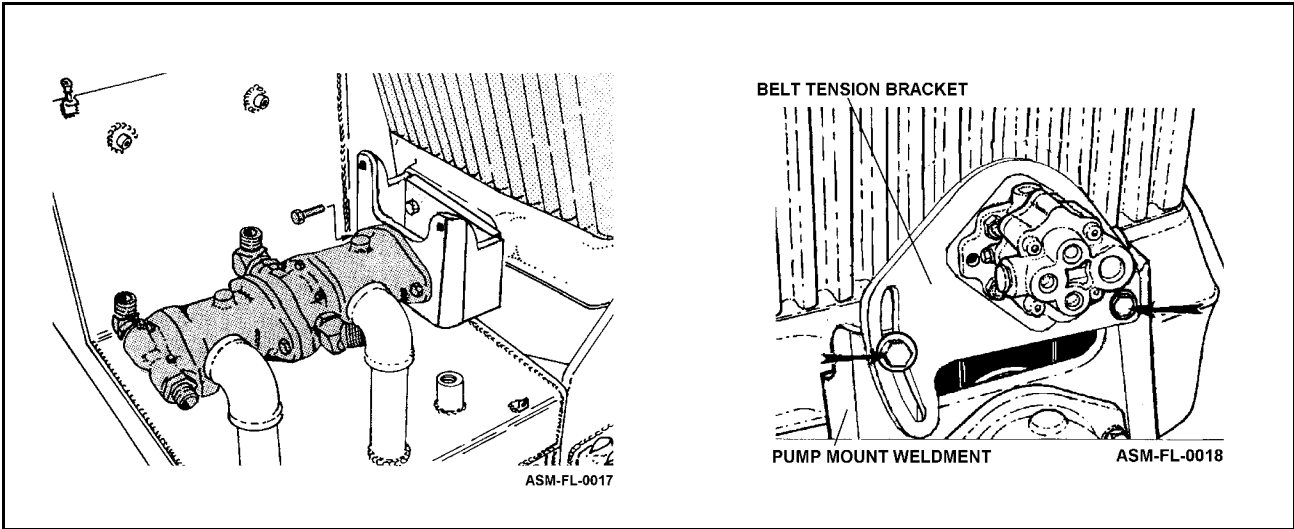

ELECTRICAL WIRING INSTALLATION



To prevent any damage to electrical system during wiring procedures, temporarily remove the negative lead (ground) from battery terminal. **Asm-R-0018**

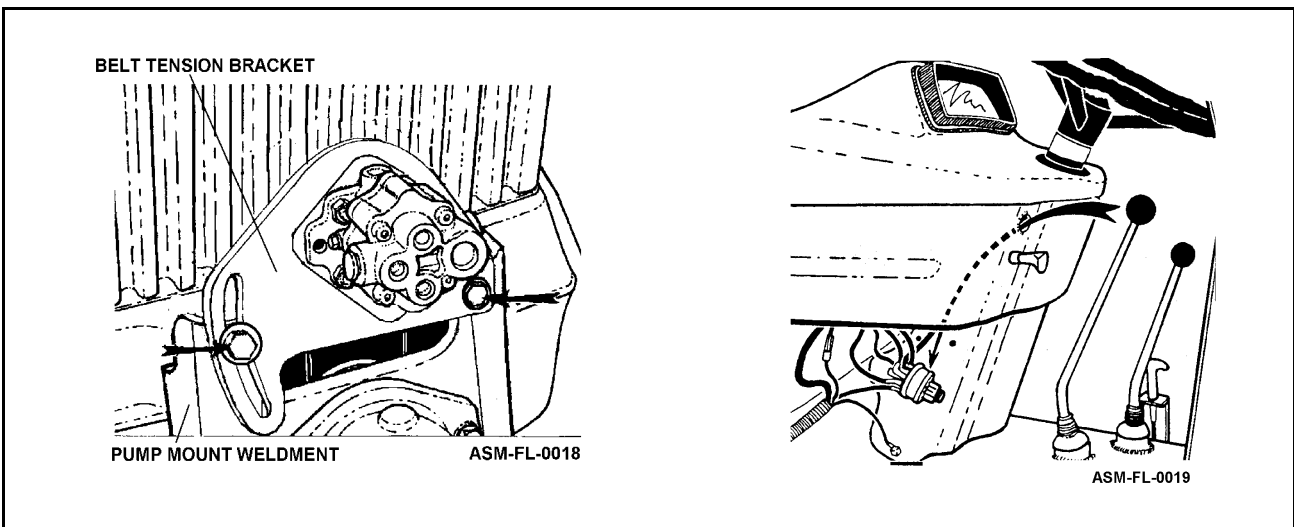

Remove ignition switch access panel or ignition switch if panels are not provided in dash. Identify the "Ignition-Start" wire and the "Ignition-Accessory" wire. **ASM-FL-0019**

ASSEMBLY

Using the wire identified as "Ignition-Start" leading from ignition switch to starter solenoid, cut wire approximately 3" from ignition switch. Using the internal and external bullet connectors provided, install the "Line-connector" (internal) onto wire at ignition switch which is 3" long. Install the "Bullet-Terminal" (external) onto the wire leading to starter solenoid.

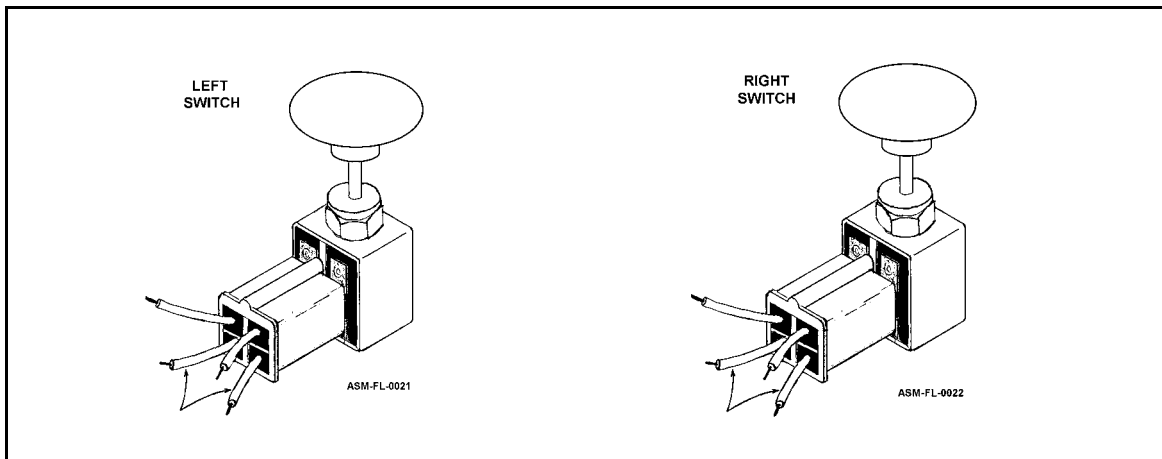

ASSEMBLY

ELECTRICAL CIRCUIT

Using **ASM-FL-20-22** as a guide, install electrical components and wiring.

Wires from the safety switch must be routed close to cutter housing sidesheet and lift frame pivot points. This will prevent wires from being stretched and broken when cutter housing is raised or lowered to maximum positions.

NOTE: Route wires in such a manner to prevent interference with the operation of tractor or INTERSTATER. Ensure that wires DO NOT lay against anything which could wear through insulation and cause a short circuit.

After connecting all wires, wrap wires with flexguard tubing. Neatly gather hydraulic hoses and flexguard tubing and strap together using plastic ties.

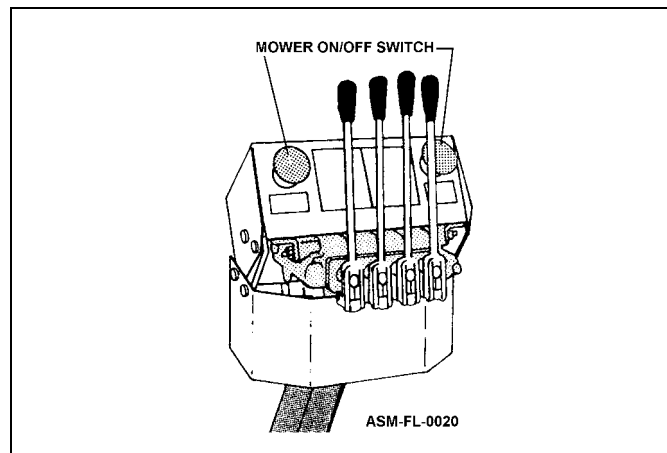

NOTE: Be sure to install connector so that larger brown wires are located on bottom poles of switch. This applies to Dual Wing and Single Wing applications.

ASSEMBLY

ASSEMBLY

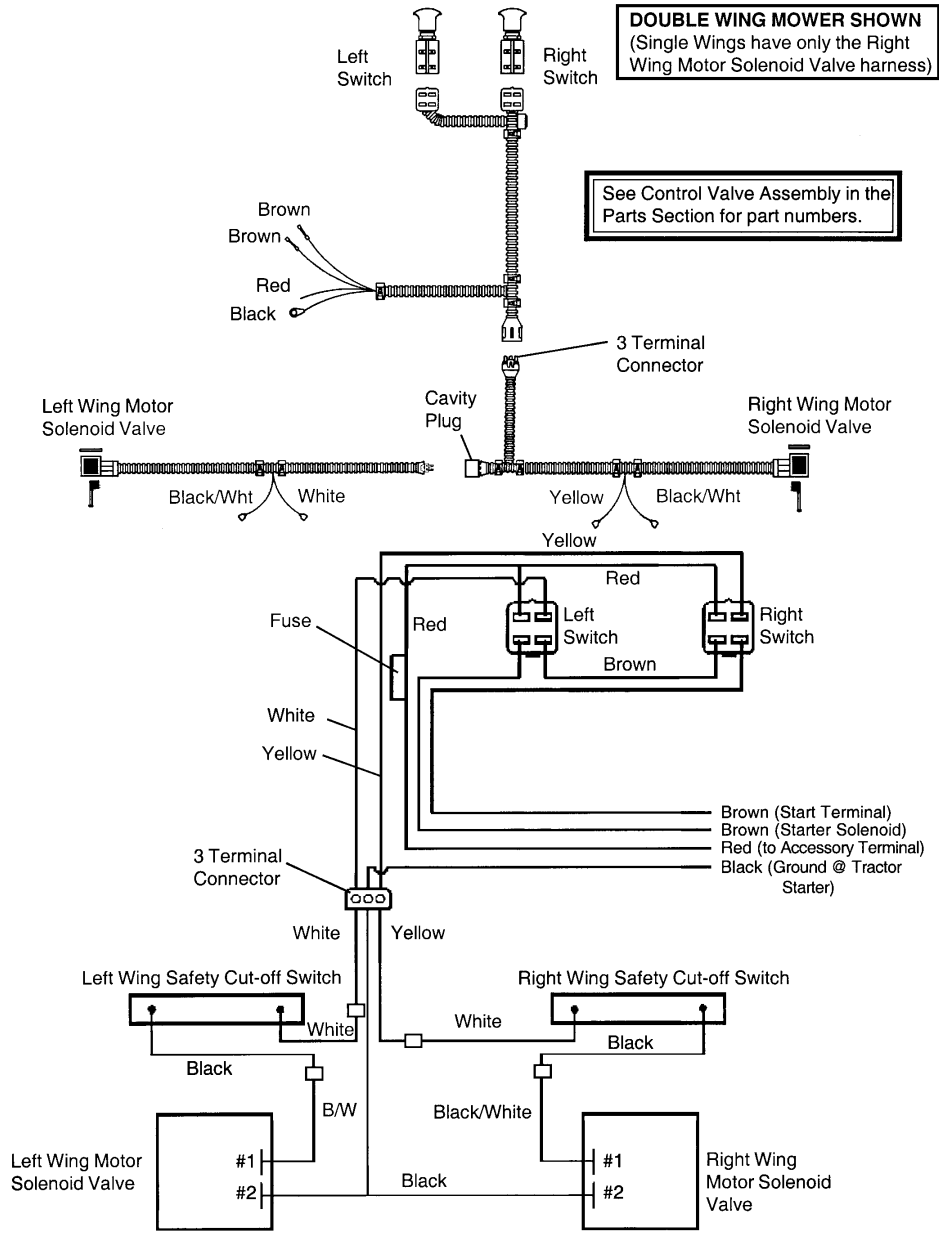

ASSEMBLY

CONTROL VALVE

Attach valve stand to the top of the right lift cylinder support with (3) 1/2" x 1-1/2" bolts, and (3) 1/2" locknuts. **ASM-FL-0024**

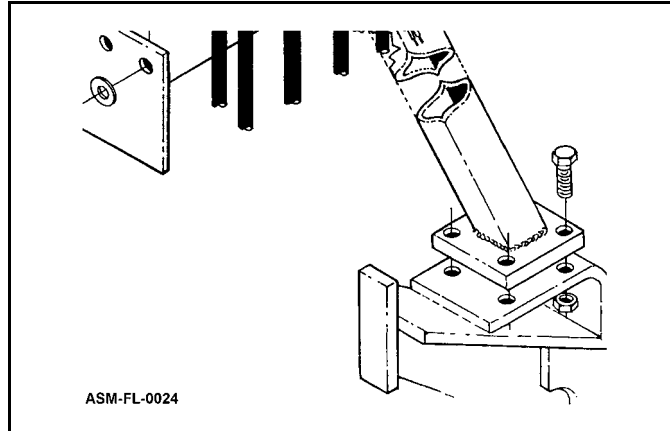

Attach valve stand to the valve mount bracket with (2) 3/8"x1-1/4" bolts and (2) 3/8" locknuts. **ASM-FL-0025**

Attach control valve to the valve stand with (2) 3/8"x1" bolts, (2) 3/8" locknuts. Attach the top cover and the bottom cover to the valve mount bracket with (8) 3/8"x1" bolts, (8) 3/8" washers and (8) locknuts. **ASM-FL-0026**

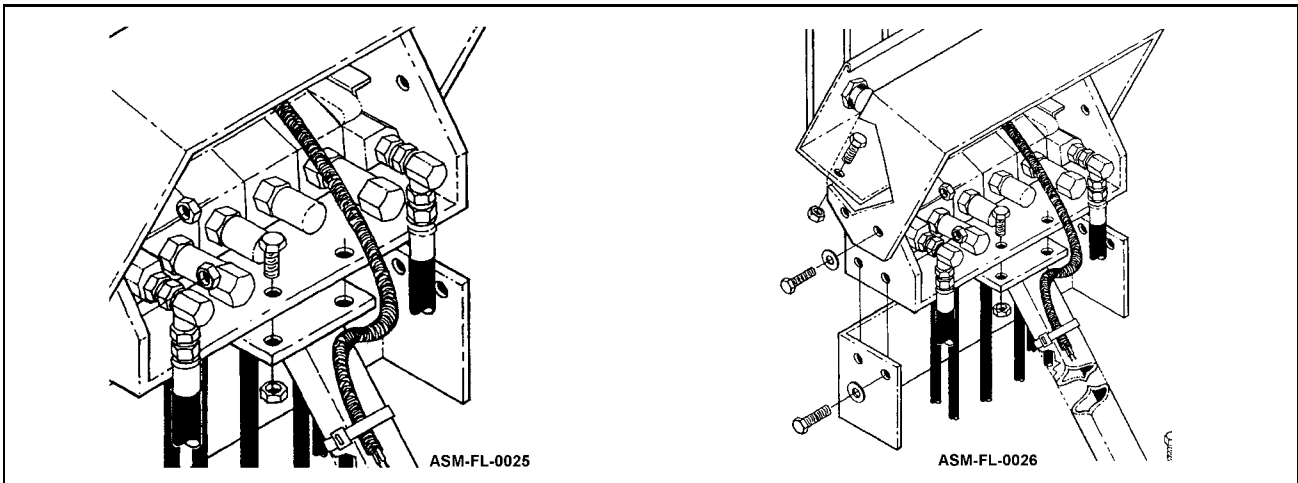

ASSEMBLY

HYDRAULICS

⚠ WARNING

Refer the Tractor Manual when connecting hydraulic hoses to the tractor hydraulic system. Not only does the installation procedure vary from tractor to tractor, but numerous precautions should be taken due to the possibility of a pressure buildup within the hydraulic circuit. Relieve the pressure before opening or entering the circuit. **FLUID ESCAPING UNDER PRESSURE CAN PENETRATE THE SKIN CAUSING SERIOUS INJURY.** Ensure that hose fittings are secure before pressurizing the hydraulic systems.

Important

Once pumps and belts are installed, **DO NOT** start the tractor (which will turn pumps) unless both power circuits are filled with the specified hydraulic fluid. Running pumps without oil will cause non-warrantable damage.

It is important that pipe thread sealant be used only on solid connections of pipe thread; never on connections between swivel fittings and solid male pipe threads or on straight thread "O" ring fittings. Use the pipe thread sealant supplied. Do not substitute with some other type of sealant, i.e., teflon tape, paint, shellac, etc.

Hoses supplied have two types of fittings; solid or swivel. Some hoses have solid fittings on both ends; others have a solid fitting and a swivel fitting. Hoses with two solid fittings will fit into either a female solid thread, or a swivel adapter union. When installing either type hose, solid fittings must be installed first, then install the swivel end of the hose.

The INTERSTATER hydraulic system incorporates three basic types of hydraulic fittings:

- a. Standard pipe (NPT or NPTF) thread fittings. This type requires a small amount of evenly-applied sealant.
- b. Swivel fittings. This type does not require any sealant on the swivel end because it seals against an internal flare.
- c. "O" Ring fittings. This type does not require any sealant on the "O" Ring end of the fitting.

It is extremely important to avoid getting pipe thread sealant inside the fittings or hoses. **KEEP THE INTERIOR OF ALL HYDRAULIC COMPONENTS SURGICALLY CLEAN.** Inspect the inside diameter of each hose before assembly. Ensure that no obstruction is present. Dirt, sand, dust, etc., are abrasive and once in the system can cause immediate or early failure.

POWER CIRCUIT

Using the following drawing and your installation drawing as a guide to install the hydraulic hoses and fittings for the power circuit. The power circuit drives the Interstater wing cutter units. The control circuit (for lift and tilt) will be assembled later.

NOTE: *Do not strap hoses together until all hoses and wiring are connected. Hoses and wiring should be routed so they do not lay on moving parts, too close to sharp edges, or near excessive heat.*

ASSEMBLY

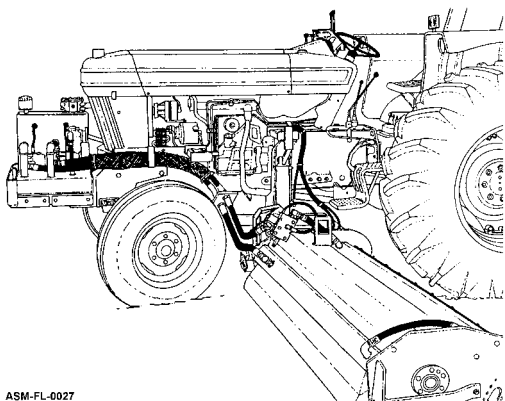

ASM-FL-0027

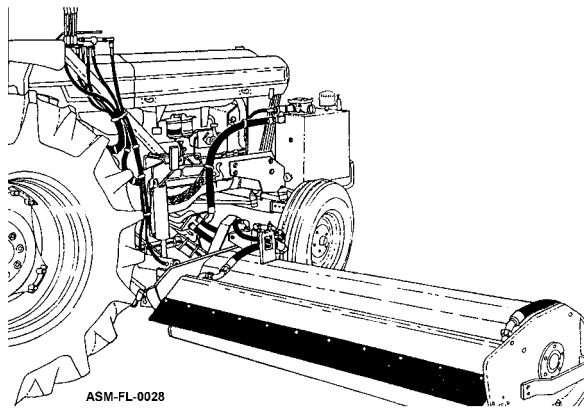

ASM-FL-0028

ASSEMBLY

1. Attach the two Pump Case Drain hoses p/n 001788 (Item 1 and 2) from the Hydraulic Pump to the Hydraulic Tank. **ASM-FL-0029**
2. Attach the two Suction hoses p/n 001783 (Items 3 and 4) from the Hydraulic Pump to the vertical suction tubes on the hydraulic tank. **ASM-FL-0029** Fit hoses and cut to length so that there is no kink after they are installed.
3. Attach the left wing pressure hose (Item 1) to the first Hydraulic Pump. **ASM-FL-0030**
4. Attach the right wing pressure hose (Item 2) to the second Hydraulic Pump. **ASM-0030**
5. Slide the Protective Sleeving (Item 3) over these hoses. **ASM-FL-0030 & 0031**

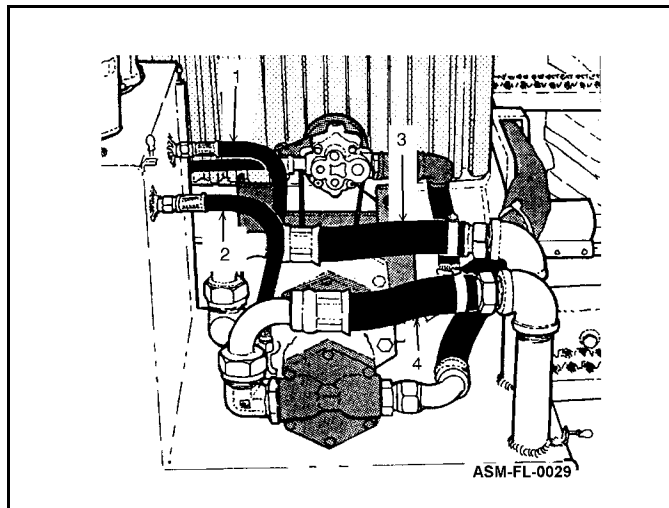

ASM-FL-0029

ASSEMBLY

ASSEMBLY

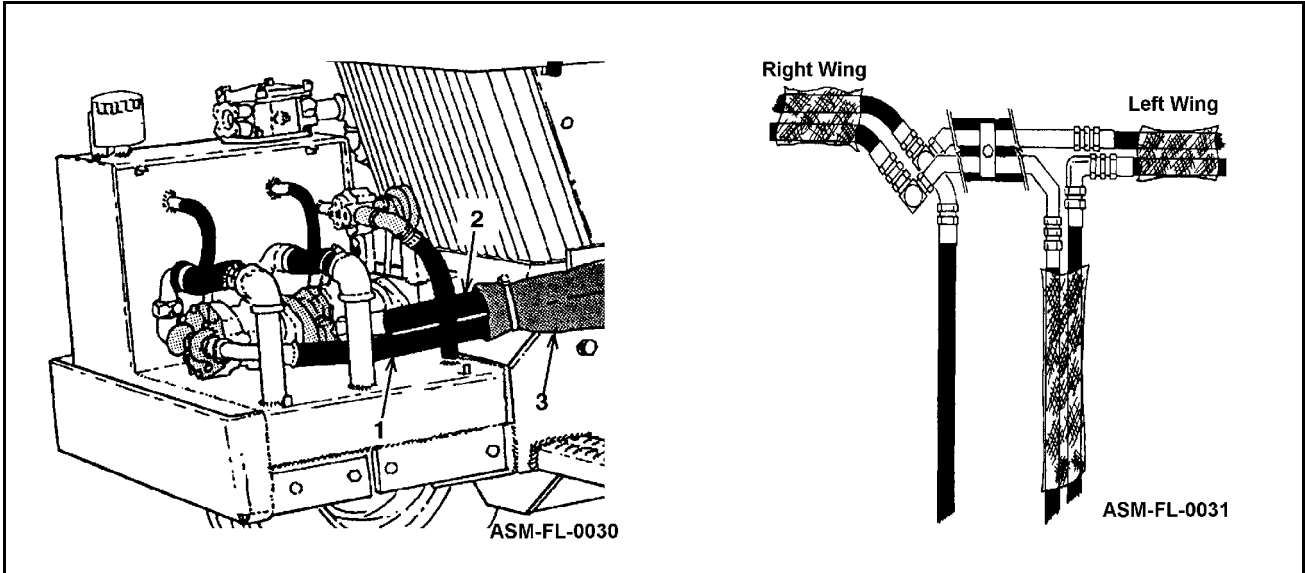

6. Attach the Return Hose (Item 1) to Left Wing **ASM-FL-0032 & 0033** Slide Protective Sleevling (Item 2) over the Return Hose.

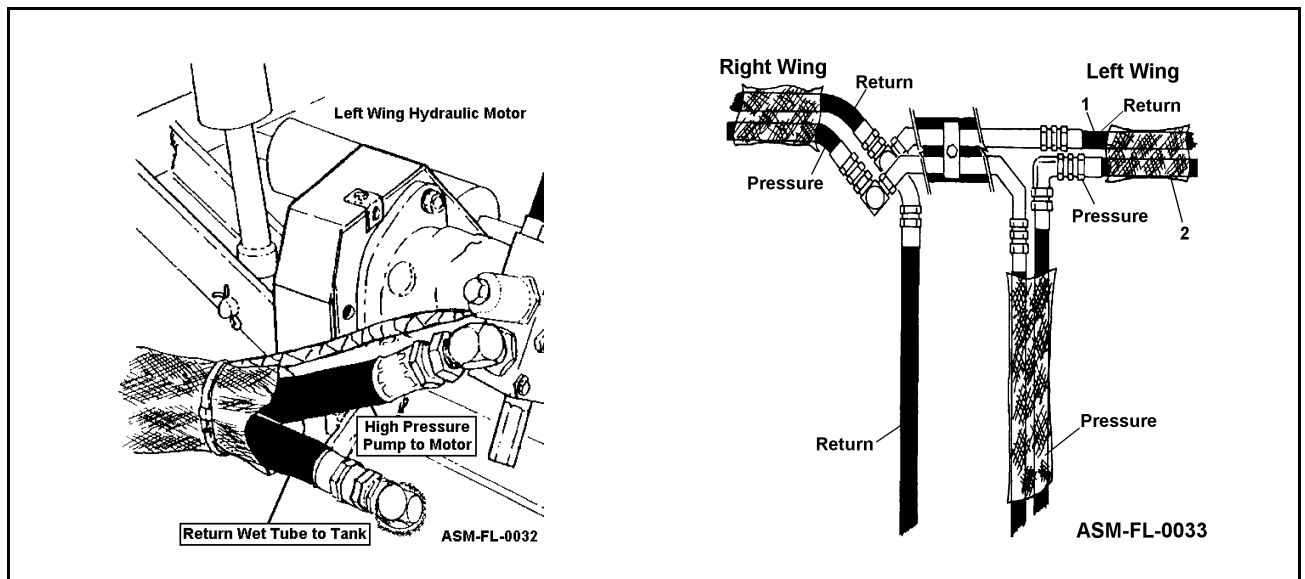

ASSEMBLY

ASSEMBLY

Slide the left wing pressure hose (Item 1) through the protective sleeving (Item 2) and attach to the left wing hydraulic motor. **ASM-FL-0034 & 0035**

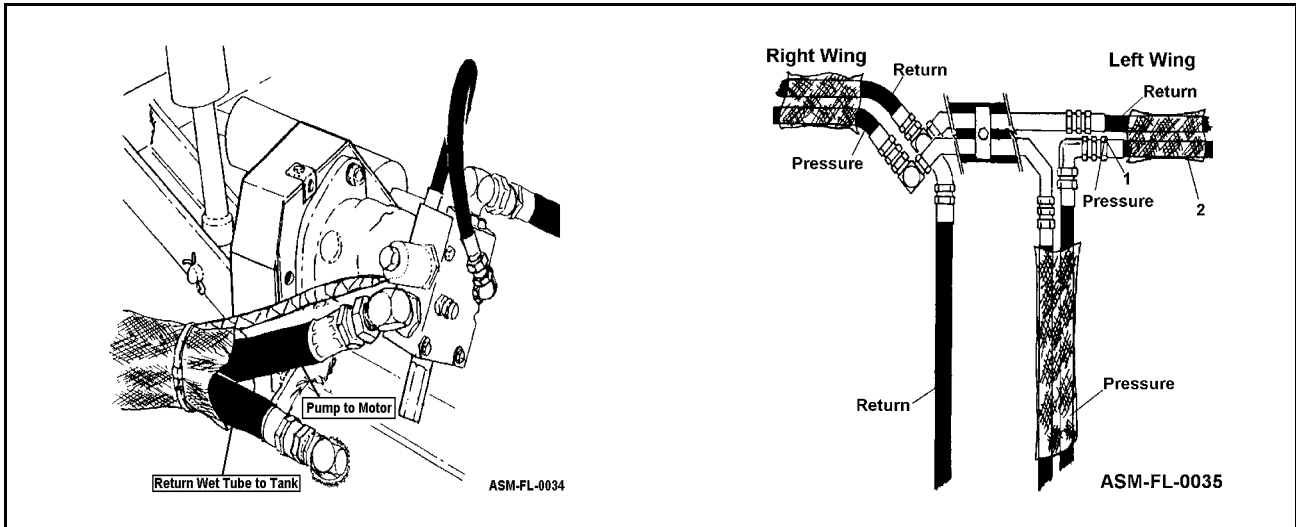

Slide right wing pressure hose (Item 1 **ASM-FL-0036 and 0037**) through protective sleeving (Item 4 **ASM-FL-0037**) and attach to right wing hydraulic motor.

Attach right wing return hose to hydraulic adapter (Item 3) on right wing (Item 2 **ASM-FL-0036**) and slide through the sleeving. This sleeving will now have both right wing pressure hose and right wing return hose. **ASM-FL-0037**

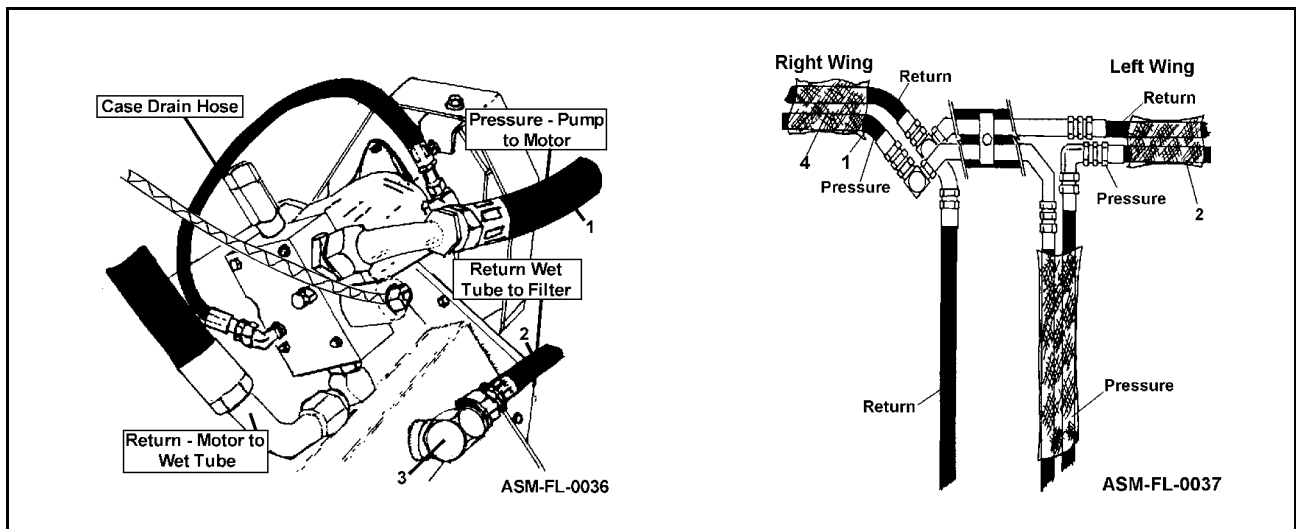

ASSEMBLY

ASSEMBLY

Attach the return hose to the return filter on the hydraulic tank. **ASM-FL-0038** Attach the other end of the return hose to the 3-way fitting on the hard plumbing. **ASM-FL-0039**

NOTE: the nut on the 3-way fitting must be loosened before the return hose can be attached. **ASM-FL-0039**

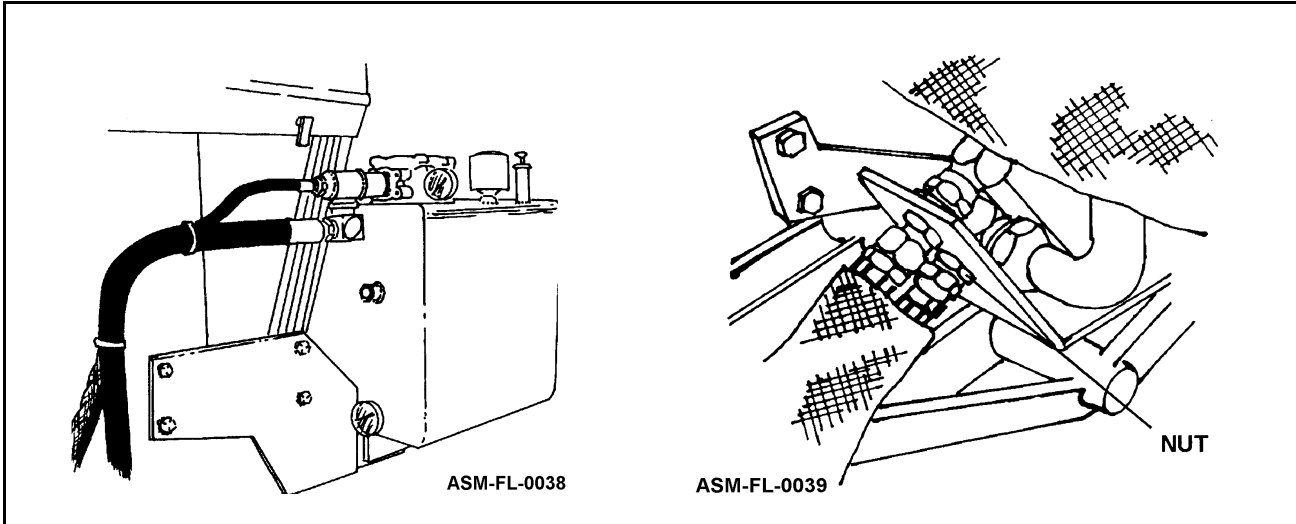

Install the vent plug P/N 000696 (Item 1) **ASM-FL-0040** plug into upper port of each lift cylinder

NOTE: On some model, lift cylinder ports must face forward for proper hose clearance.

Install the 90 deg. elbow fittings P/N 02045200 (Item 2) **ASM-FL-0040** into the remaining lift and tilt cylinder ports

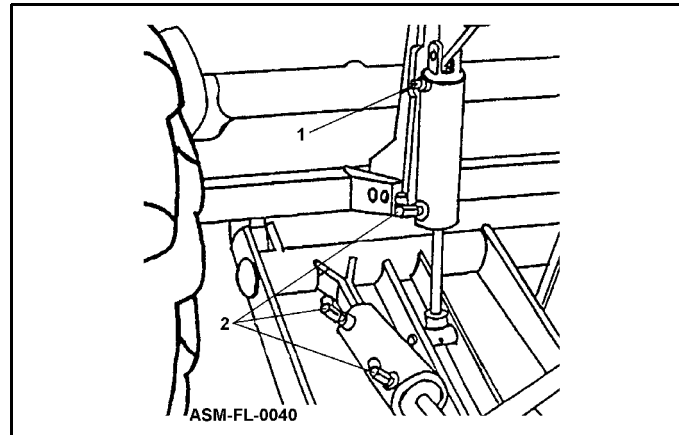

ASSEMBLY

Attach suction hose (Item 1) **ASM-FL-0041** from auxiliary pump to hydraulic tank.

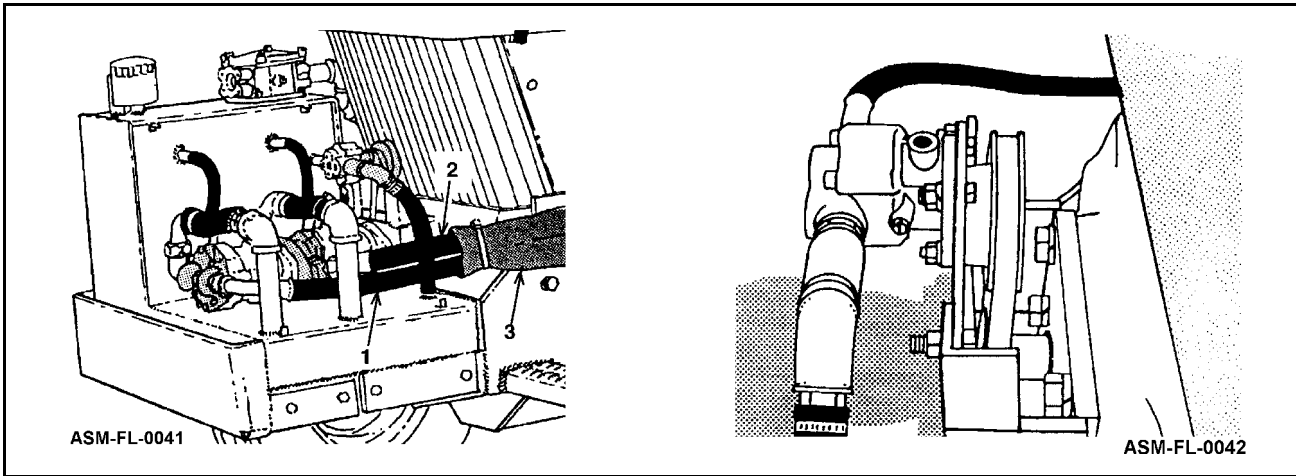

Attach the pressure hose (Item 1) **ASM-FL-0042** from the auxiliary pump to the control valve (Item 1) **ASM-FL-0042**

Attach the return hose (Item 2) **ASM-FL-0043** from the control valve to the return filter on the hydraulic tank (Item 1) **ASM-FL-0044**.

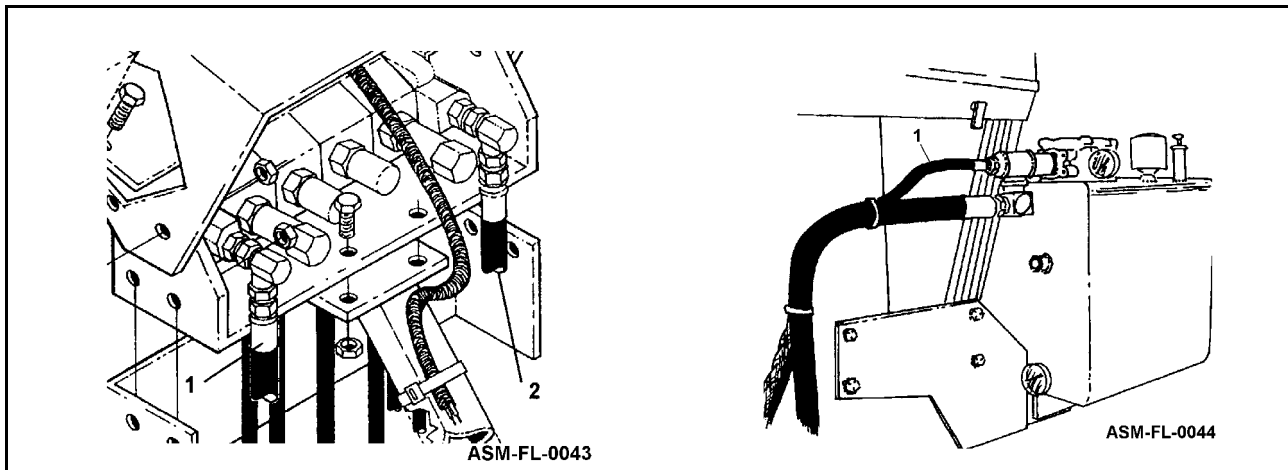

ASSEMBLY

ASSEMBLY

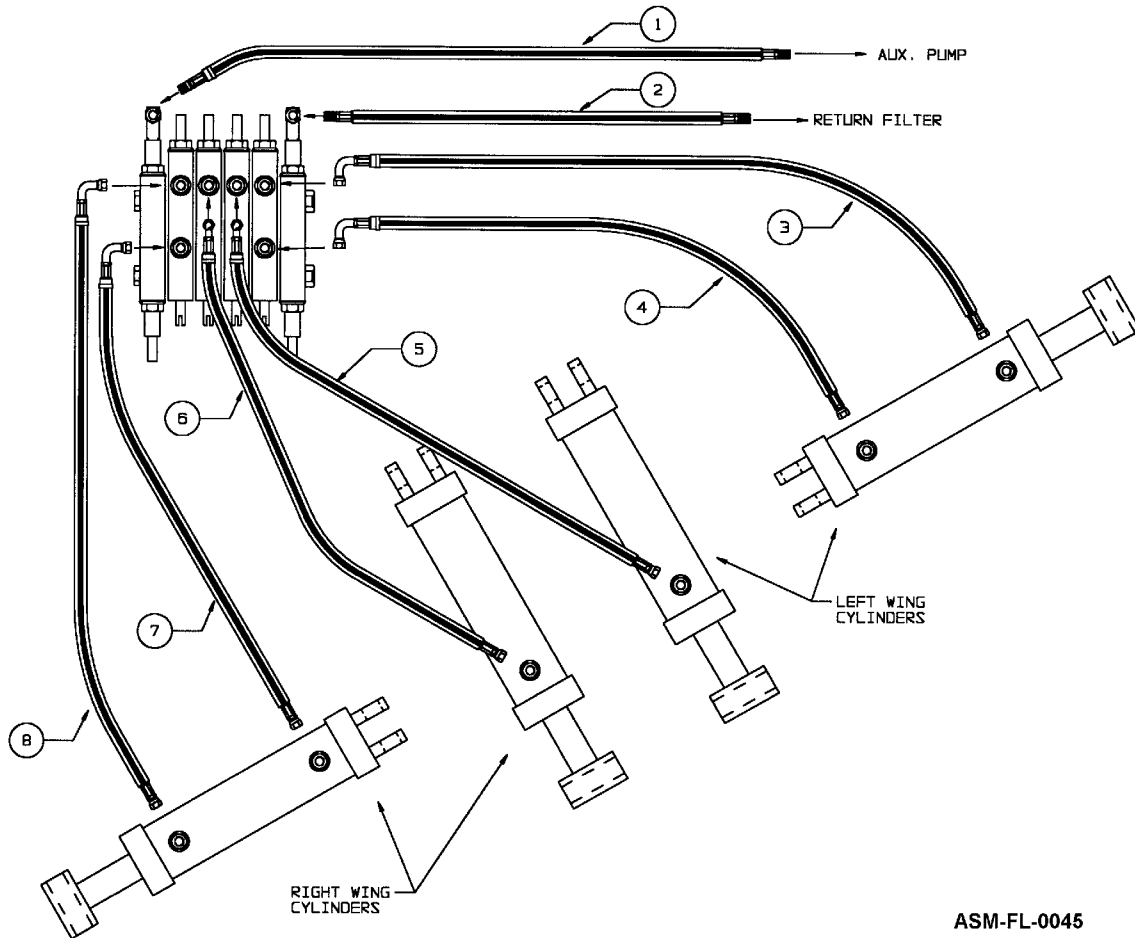

ASM-FL-0045

ITEM	PART NO.	QTY	DESCRIPTION
8*	001775	1	Hose - Control Valve to Pump
7*	001776	1	Hose - Control Valve to Return Filter
6+	001773	1	Hose - Control Valve to Tilt Cyl. - Live End
5+	001774	1	Hose - Control Valve to Tilt Cyl. - Dead End
4+	001772	1	Hose - Control Valve to Lift Cyl. - Live End
3+	001771	1	Hose - Control Valve to Lift Cyl. - Live End
1+	001770	1	Hose - Control Valve to Tilt Cyl. - Dead End
2+	001770	1	Hose - Control Valve to Tilt Cyl. - Live End

+ Hose used with most non-cab tractors

* See Installation Instructions that were shipped with your unit for proper replacement part numbers.

ASSEMBLY

CONTROL CABLE CONNECTION TO CONTROL STICK ASSEMBLIES

First remove the Cross-Screw from the bottom of the Control Stick Assembly. DO NOT remove the screws that fasten the two housings halves together. **ASMP-FL-0001**

Next while holding the housing, fully shift the Handle in the Control Stick Assembly to expose the female-threaded end of the Plunger Rod. **ASMP-FL-0002**

Then while holding the Handle to expose the Plunger Rod, thread the Threaded Bead **ASMP-FL-0003** of the Cable into the end of the Plunger Rod and tighten securely. Release the Handle, allowing the Cable to pull into the Control Stick Assembly.

Once Cable is attached to Plunger Rod, slide the silver Conduit Sleeve **ASMP-FL-0004** into the bottom of the Control Stick Assembly and align the groove in the Conduit Sleeve with the Cross-Screw Hole.

Finally Reinstall the Cross- Screw and tighten securely.

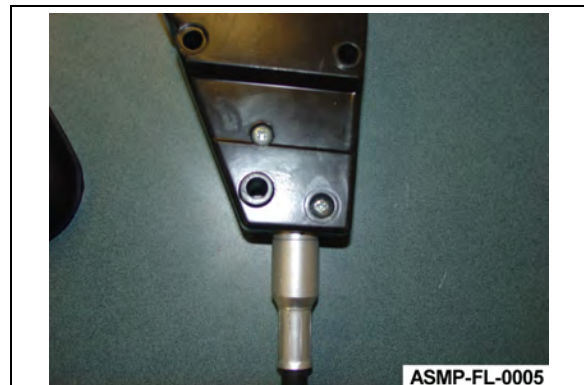
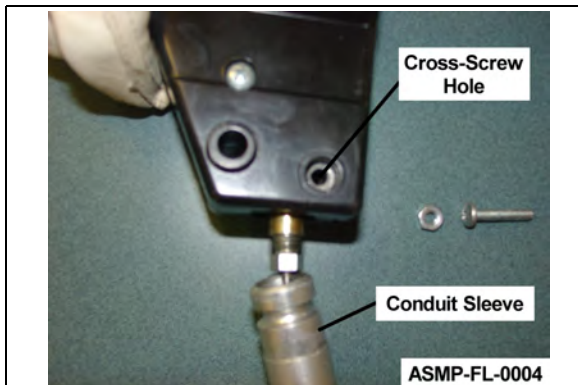
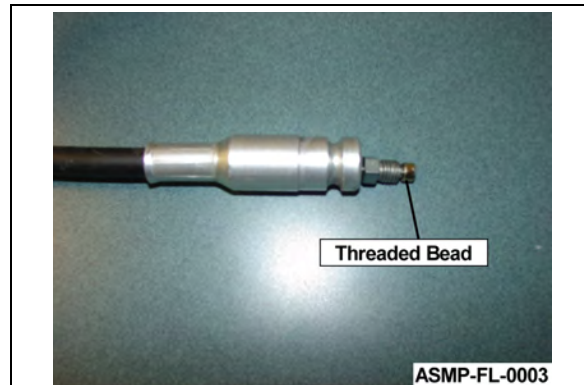
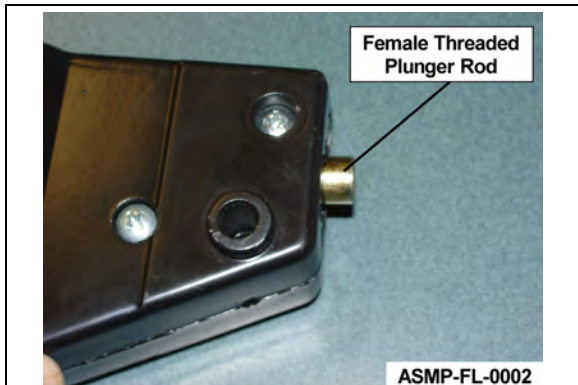
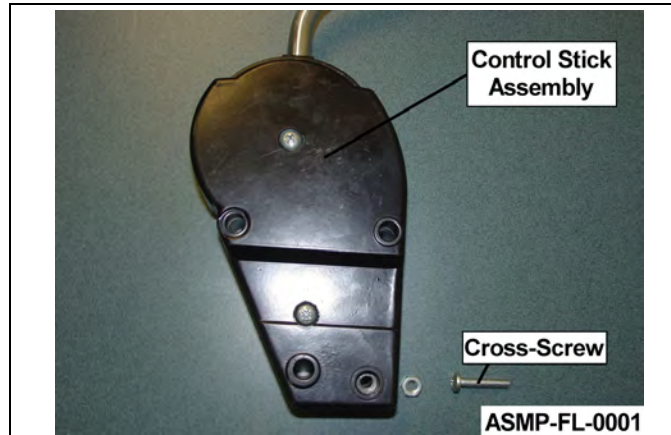

ASSEMBLY

INITIAL START-UP PROCEDURE

1. Check all nuts and hex head capscrews to ensure all are tight and all lock washers are fully compressed (flattened).
2. Check all hoses and hydraulic connections. Make certain they are secure.
3. Inspect all moving parts and be sure that no wires or hoses will be caught or pinched when the tractor or the INTERSTATER is in operation. Tie down loose wires and hoses.
4. Thoroughly grease the INTERSTATER and install a lubricap on each grease fitting. Refer to the Operation and Maintenance Section.
5. Jack front of tractor up enough to allow axle to pivot through its full range. While turning wheels through their limits, right and left, swing them up and down. Look for interference between tires and any part of the INTERSTATER. If interference occurs, shims (not furnished) must be welded to axle pivot stop or steering arm to limit the movement enough to avoid interference. Tractors with an adjustable front axle may require an outward adjustment of the wheels.
6. To fill the INTERSTATER reservoir with new, clean hydraulic oil, follow the steps below. Refer to the Operation and Maintenance Section for specifications.
 - a. With a hydraulic jack raise the right side of the tractor. This will tilt the tank and allow only a minimum amount of air when filling.
 - b. Avoid hydraulic contamination by filtering the hydraulic oil while filling the hydraulic tank. **ASM-FL-0038**

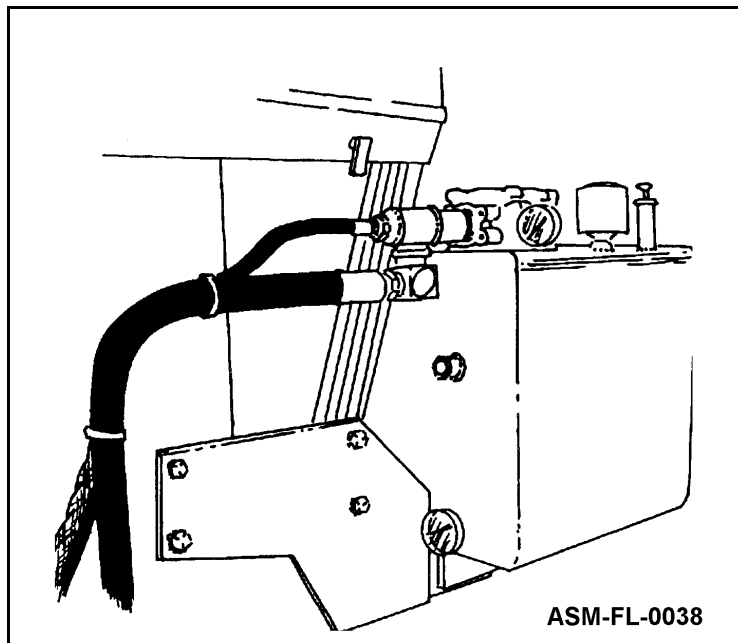

ASSEMBLY

Filter buggies or carts are commercially available for hydraulic system clean-up. These consist of a high-efficiency, high-capacity filter, a circulating pump, a drive motor, and hoses for connecting the overhauled machine's hydraulic system.

ASM-FL-0048

After the first 10 hours of operation, replace the hydraulic filter with a new one. An extra Filter Element is provided for you. Refer to the Operation and Maintenance Section for instruction.

7. After the Interstater mower is completely assembled to the tractor and with the wings on the ground, fill the mower hydraulic tank above the oil level sight gauge approximately 5" or 1" below the top of the tank.

8. With mower ON/OFF switches in "ON" position and tractor fuel cut off, crank engine for about 30 to 45 seconds to allow oil to fill pumps and motors. Check the oil level in the sight gauge. If no oil is seen add oil to bring the level up to the sight gauge. **NOTE:** Do not fill the tank with oil above the level of the sight gauge. Over filling the tank with oil after the initial filling may result in oil being discharged through the air filter on top of the hydraulic tank. Start the tractor and run it for 2 minutes and then turn it off. Again check the oil level in the sight gauge. If the oil level is in the sight gauge, the unit is ready to run. If no oil is seen, add oil to bring the level up to the sight gauge.

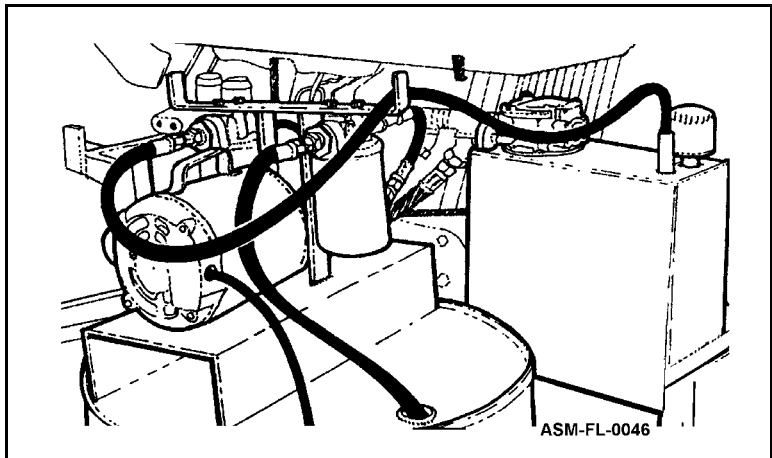

ASSEMBLY



Remove all foreign objects and stand clear of cutter units. **DO NOT GET NEAR ROTATING KNIVES!**

NOTE: On tractor hydraulic powered circuit only, make certain that there is full flow from tractor hydraulic system to control valve. Refer to tractor manual.

9. After hydraulic system is fully charged and functioning properly, switch cutter units on, then speed engine up to 540 RPM PTO speed. Maintain this speed for about 5 minutes. Check complete INTERSTATER, look for any leaks, loose connections, or anything that could cause premature wear or failure.

FINAL CHECK

Run INTERSTATER for about 1/2 hour at full speed. Check for leaks and vibrations. Frequently check oil temperature. Make certain it does not exceed 180 deg.

NOTE: When raising wings, make certain there is no interference with mower, frame, cylinders or tractor. Lift wings slowly.



DO NOT leave unit unattended, and **COMPLY WITH ALL WARNING DECALS.**

If unit starts to make unusual noise, stop unit and check oil level. Also check for frothy oil which would indicate a leak on suction side of system.

ASSEMBLY

INSTALLATION OF REAR MOWER

Before attaching mower to tractor, it will be necessary that each tractor lower hitch arm has freedom of movement so that the mover is completely independent of tractor movement. This will allow the mower to pivot sideways as well as move vertically.

Some tractors provide this "float" by means of an optional slot in the lower end of each lift link, others by lift links which can be made telescopic by changing the position of the pins in the links. Failure to provide "float" may result in failure of the cutterhousing and bearings in the roller, thus voiding the mower warranty. Should your tractor not have a built in "float" option, a flexible lift chain assembly will be required.

On all centered mowers, two flexible lift chain assemblies will be necessary to provide "float" to each lift link.

On all offset mowers, one flexible lift chain assembly will be necessary to provide "float" to the lift link on the same side that the mower is offset. The other lift link should be the adjustable stiff link furnished with the tractor.

After the mower is attached to the tractor's 3-point hitch, but before the universal slip joint is installed, and with the mover on the ground, adjust the top link of the hitch to make the mower gearbox input shaft parallel to the tractor P.T.O. shaft. This relationship provides optimum operation of the universal joints in the driveline. Driveline that is not parallel to PTO will result in vibration due to the characteristic of a universal joint that results in the output end speeding up and slowing down twice each revolution of the universal jointed shaft. Adjust the top link whenever the cutting height is changed.

1. Tip cutterhousing back and place a block under roller to safely support unit. Remove shipping skids and drive pulley side belt guard fender. If necessary, install knives, as shown, one row at a time. **ALL KNIFE PINS ARE INSTALLED WITH THEIR HEADS FACING AWAY FROM THE CUTTERSHAFT PULLEY.** This will locate cotter pins where knives cannot reach them when flexing backward. The housing side sheet has a hole in it which allows knife pins to be inserted into end lugs from outside the cutterhousing. After the cotter pin is installed, bend extended prong at a 45 Degree angle with prong parallel to lug. **ASMP-FL-0047**

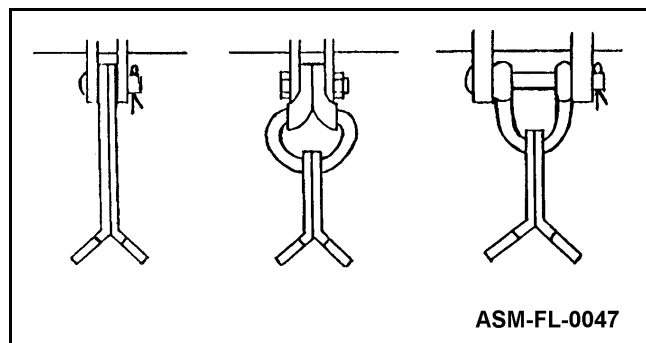

IMPORTANT: Scan this QR Code with your smart phone to link to the PAMI Safe Implement Hitching Manual for more information on correctly connecting agricultural tractors to implements. Or type in your internet browser the following web address: www.algqr.com/hme *Ops-0008-MISC*



ASSEMBLY

With the cutterhousing tipped up, attach housing shoes/wearplate. Carriage bolt attaches to front mounting hole; plow bolts attach to middle and rear holes.

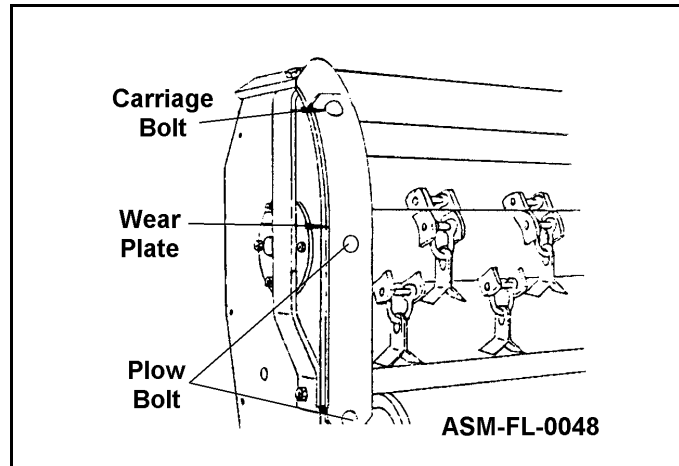

1. Attach overarms to cutterhousing. Secure each in 2 places with 5/8 NC x 1-3/4 Hex Head Capscrew(#1), and nut.
2. Attach "A" frame arms to front of cutterhousing. Secure each, plus overarms in place with 5/8 NC x 2-1/2" HHCS, and nut(#2).
3. Attach gearbox mounting frame to overarms and A- frame arms. **ASM-FL-0049**
 - a. Secure with 5/8 NC x 1-3/4 HHCS and nut (#3). Torque to 170 ft-lbs.
 - b. Secure with 3/4 NC x 3-3/4 HHCS, A- frame spacer and nut(#4). Torque to 300 ft-lbs.

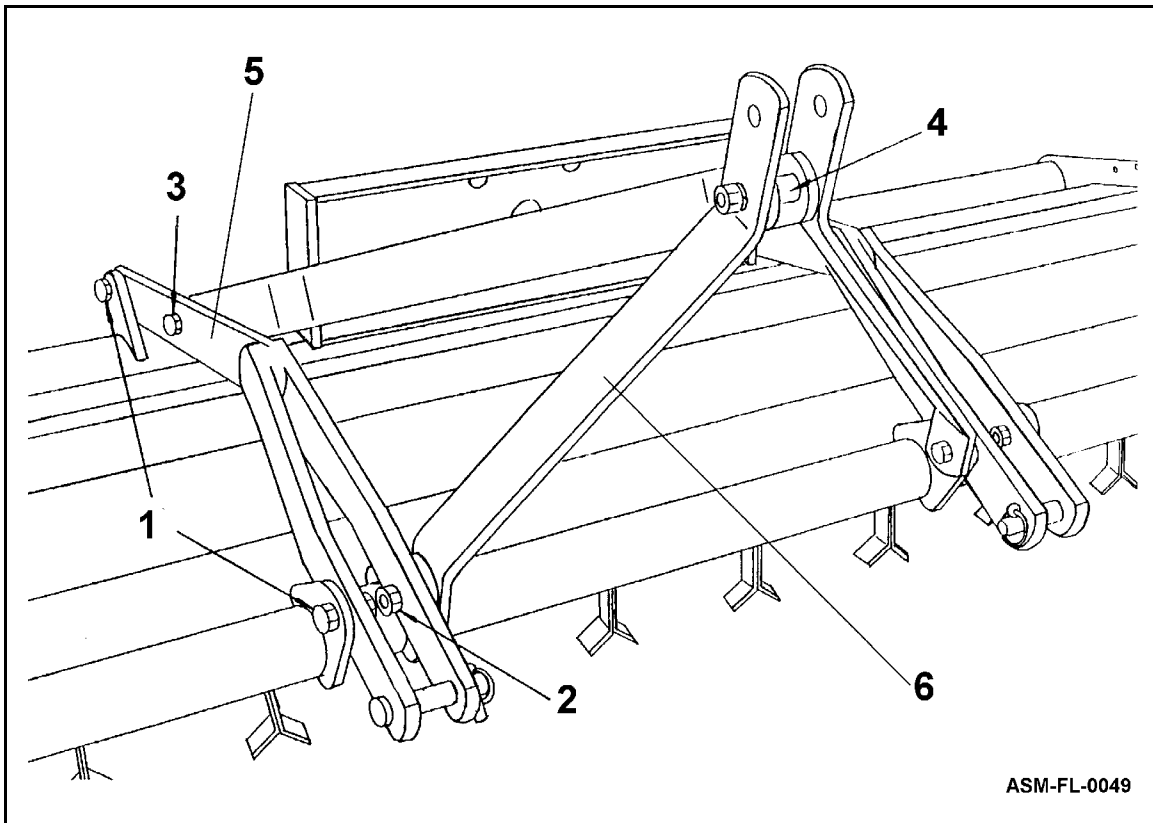

ASSEMBLY

1. Attach outboard bearing plate to cutterhousing.

FORWARD ROTATION (Bearing plate mounts on left side of cutterhousing.)

- Secure with 3/8 NC x 7/8 HHCS and nut at front mounting hole. Torque to 35 ft-lbs. (Typ.)
- Secure with 3/8 NC x 2-1/4 HHCS, nut, lock washer, and second nut at rear mounting hole. The HHCS is used as an anchor for the idler arm spring.

REVERSE ROTATION (Bearing plate mounts on right side of cutterhousing)

- Secure with 3/8 NC x 2-1/4 HHCS, nut and second nut at front mounting hole. The HHCS is used as an anchor for the idler arm spring.
- Secure with 3/8 NC x 7/8 HHCS and nut at rear mounting hole.

2. Install gearbox & extension shaft assembly and PTO shield mounting bracket

- Remove existing nuts and lock washer from bearing housing.

NOTE: On forward rotation units, remove only the lower two fasteners.

- Slide bearing housing HHCS into proper holes in outboard bearing plate.
- Attach gearbox and mounting bracket to gearbox mounting frame. Secure with 5/8 NC x 1-1/4 HHCS (upper gearbox feet), and 5/8 NC x 1-1/2 HHCS (lower gearbox feet) and Lockwashers. Torque to 170 ft-lbs. (Typ.)

Important

If extension shaft does not line-up with Gearbox, it may be necessary to shim gearbox mounting lugs. To accomplish this, insert one gearbox retaining bolt (Item 1), **ASM-FL-0050** thru the mount plate and into the gearbox housing. Do not tighten this bolt (it should have at least 1/4" free threads to move in and out). Assemble the gearbox, shaft, shaft extension tube and the bearing to the bearing retainer plate mounted on the side sheet. Tighten all fasteners except the one bolt in the gearbox mounting plate. Check the distance between the gearbox mounting lugs and the mount plate. If required, insert shims from shim kit (P/N 000552), **ASM-FL-0051** between gearbox mounting lugs and mounting plate to insure the gearbox pulls up evenly on the mounting plate.

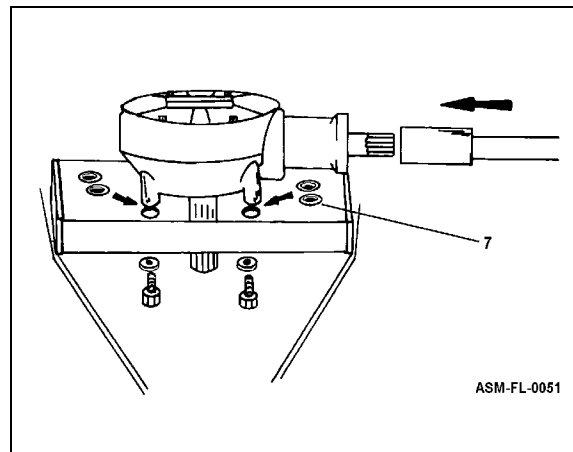
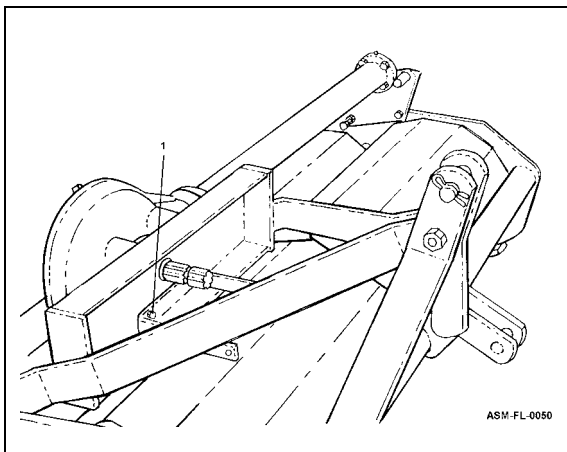

ASSEMBLY

Install idler arm assembly to bearing plate. Do not secure at this time. **ASM-FL-0052**

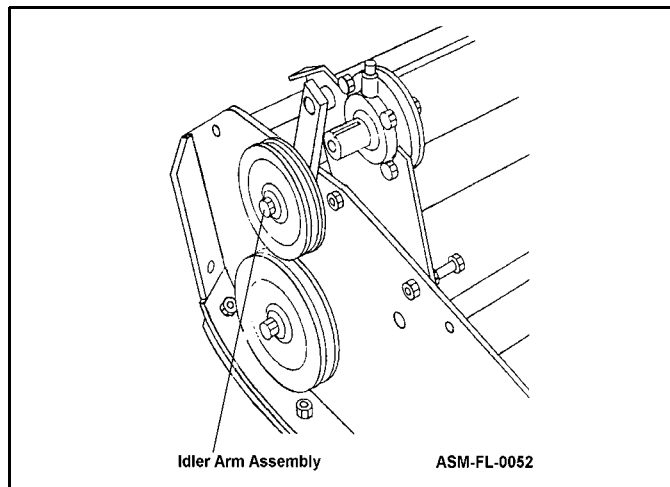

3. Remove fasteners and shaft protector from end of drive shaft and retain. Lightly grease shaft. Install key and driveshaft pulley. Do not secure at this time.
4. Align all three pulleys. Use spacers and shims provided to achieve alignment, then secure idler arm assembly with cotter pin #4. Secure driveshaft pulley #1 with fasteners that were retained during previous step.
5. Install drive belt #2.
6. Attach spring. One end is inserted in idler arm spring arm hole; the other end is attached to the long outboard bearing plate capscrew.

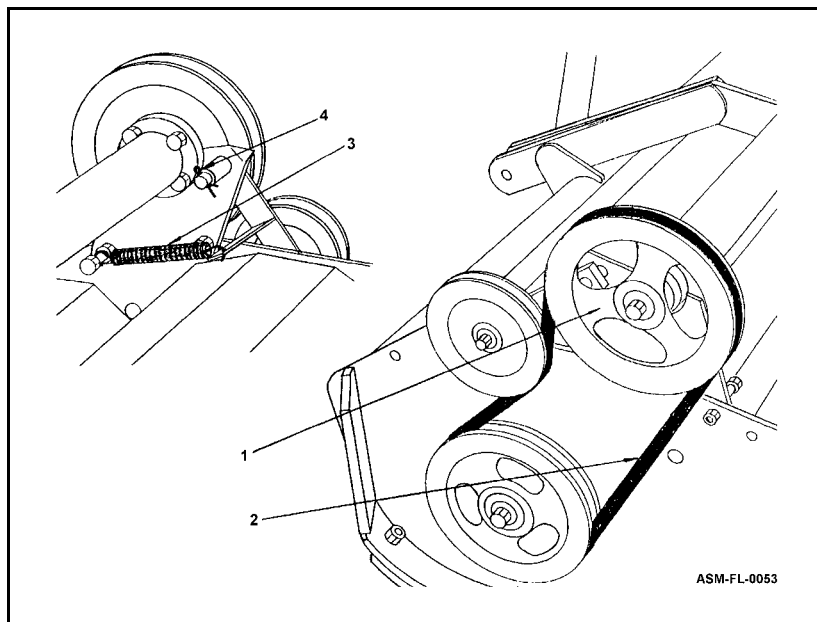

ASSEMBLY

ASSEMBLY

1. Properly mount rear mower to tractor and install driveline. See INSTALLATION AND DRIVELINE SECTIONS.
2. Attach PTO shield to mounting bracket. Snap-on shield is positioned so lower ears engage holes in bracket; upper ears rest on top of bracket. Bolt-on shield is secured with 3/8 NC x 3/4 HHCS (4 places).
3. Attach belt guard to cutter housing then reattach belt guard fender.

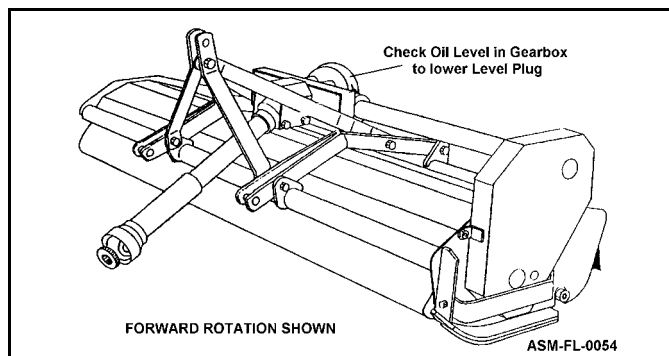

IMPORTANT: Scan this QR Code with your smart phone to link to the ADMA Driveline Safety Manual for more information on the safe use of a driveline during normal operation and maintenance. Or type in your internet browser the following web address: www.algqr.com/dme Ops-0009-MISC



Belt Guard, FORWARD ROTATION

Three 1/2 NF x 1-1/4 HHCS and nuts.

Belt Guard, REVERSE ROTATION

One 1/2 NF x 1 HHCS (upper attaching pollinator 1/2NF x 1-1/4 HHCS two plain washers, and one nut. Plain washers are located at upper two belt guard attaching points.

UNIVERSAL SLIP JOINT (PTO SHAFT): Refer to instructions supplied with shaft.

To install the driveline separates slip joint halves, then install them onto mower gearbox input shaft and tractor PTO driveline according to illustration on PTO shaft shield. Hold halves side by side, then raise and lower the mower to determine that there is no interference between halves when in the shortest position, and that there is a specified minimum amount of overlap (see PTO SHAFT - PARTS LIST section) when in the longest position. Once it is determined that the shaft will cause no clearance problems, remove the halves, rejoin them and install the assembled PTO shaft between the tractor and the mower.

After attaching PTO shaft, slowly raise and lower mower to make sure shaft will not make any contact with "A-Frame" or mower head. If a problem exists, change mounting position or lengths of lift chains by removing or adding links.

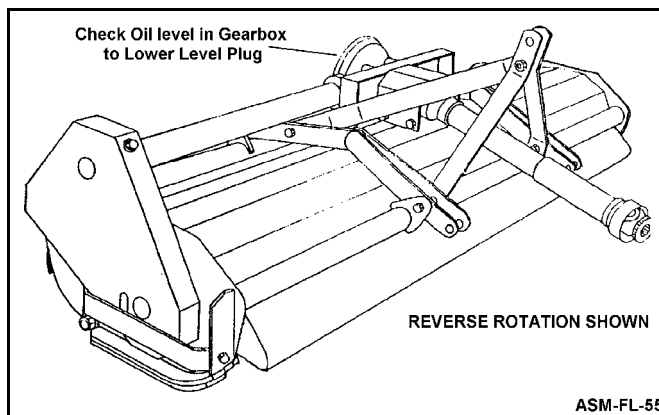

OPERATION SECTION

Operation Section 4-1

OPERATION

ALAMO INDUSTRIAL INTERSTATER OPERATING INSTRUCTIONS

Alamo Industrial Interstater flail mowers are manufactured with quality material by skilled workers. These mowers are designed for cutting grass and small weeds. The mower is equipped with protective deflectors to prevent objects being thrown from the mower by the blades, however, no shielding is 100% effective. All shields, guards, and deflectors equipped on the mower must be maintained in good operational condition.

It is the operator's responsibility to be knowledgeable of all potential operating hazards and to take every reasonable precaution to ensure oneself, others, animals, and property are not injured or damaged by the mower, tractor, or a thrown object. Do not operate the mower if passersby, pets, livestock, or property are within 100 yards of the unit.

- **All THROWN OBJECT SHIELDING** including, Front, Rear Deflectors and Skid Shoes are in place and in good condition when mowing.
- Mower is adjusted to be close and parallel to ground without exposing blades.
- **MOWING AREA** has been inspected and foreign materials and debris have been removed.
- **PASSERSBY** are inside enclosed vehicle

This section of the Operator's Manual is designed to familiarize, instruct, and educate safe and proper mower use to the operator. Pictures contained in this section are intended to be used as a visual aid to assist in explaining the operation of a Interstater flail mower and are not specific to any model. Some pictures may show shields removed for picture clarity. NEVER operate implement without all shields in place and in good operational condition. The operator must be familiar with the mower and tractor and all associated safety practices before operating the mower and tractor. Proper operation of the mower, as detailed in this manual, will help ensure years of safe and satisfactory use of the mower.

Important

To avoid mower damage, retorque all bolts after the first 10 hours of operation. Refer to the Torque Chart at the end of the Maintenance Section to ensure bolts are properly tightened.

READ AND UNDERSTAND THE ENTIRE OPERATING INSTRUCTIONS AND SAFETY SECTION OF THIS MANUAL AND THE TRACTOR MANUAL BEFORE ATTEMPTING TO USE THE TRACTOR AND IMPLEMENT. If you do not understand any of the instructions, contact your nearest authorized dealer for a full explanation. Pay close attention to all safety signs and safety messages contained in this manual and those affixed to the implement and tractor. *OPS-U- 0001*

READ, UNDERSTAND, and FOLLOW the following Safety Messages. Serious injury or death may occur unless care is taken to follow the warnings and instructions stated in the Safety Messages. Always use good common sense to avoid hazards. (SG-2)

**SAFETY
INSTRUCTIONS**



PELIGRO

Si no lee ingles, pida ayuda a alguien que si lo lea para que le traduzca las medidas de seguridad. (SG-3)

**¡ LEA EL
INSTRUCTIVO!**



OPERATION

1. Standard Equipment and Specifications

Base Unit Specifications

16'5", 18'5", or 20'9" Overall Cutting Widths

Full-Length Welded Tubular Frame With Transport Lock

19-Gallon Reservoir with 12 Micron Filtration

Tandem Piston Pumps Rated @ 48 GPM @ 3800 PSI (Dual Interstater)

Tandem Piston Pump Rated @ 24 GPM @ 3800 PSI (Right & Left Hand Interstater)

4-Spool Valve with Detent Position (Dual Wing Interstater)

2-Spool Valve with Detent Position (Right & Left Hand Interstater)

Wing Mower Specification

62", 74", or 88" Cutting Widths

1/2" Inboard & 5/16" Outboard Side Plates

Replaceable Skid Shoes

4-1/2" x 5/16" Wall Cuttershaft

1-5/16" Bore Greasable, Self-Aligning Cuttershaft Bearings

53 HP Piston Motor

Belt Drive From Motor to Cuttershaft with Automatic Spring Tension

6" Adjustable Rear Roller

1/2" to 6" Cutting Height

Available in Fine or Coarse-Cut

Front and Rear Safety Deflectors

Automatic Cut-Off Switch

Lift Cylinder Capable of 14" Vertical Lift

Tilt Cylinder Capable of 45 Degrees Down & 90 Degrees up

10 Gauge Unitized Cutter Housing

Rear Mower Specifications

88" or 96" Cutting Width (Depending on tractor mount kit)

10-Gauge Unitized Cutter Housing

5/16" Side Plates

CAT I or CAT II Three Point Hitch

4-1/2" x 5/16" Wall Cuttershaft

1-5/16" Bore Greasable, Self-Aligning Cuttershaft Bearings

60 HP Gearbox

6" Adjustable Rear Roller

1/2" to 6" Cutting Height

Available in Fine or Coarse-Cut

Torque Limiter Clutch

Front and Rear Safety Deflectors

CAT 4 Driveline

Belt Drive From Gearbox To Cuttershaft with Automatic Spring Tension

OPERATION

2. OPERATOR REQUIREMENTS

Safe operation of the unit is the responsibility of a qualified operator. A qualified operator has read and understands the implement and tractor Operator's Manuals and is experienced in implement and tractor operation and all associated safety practices. In addition to the safety messages contained in this manual, safety signs are affixed to the implement and tractor. If any part of the operation and safe use of this equipment is not completely understood, consult an authorized dealer for a complete explanation.

If the operator cannot read the manuals for themselves or does not completely understand the operation of the equipment, it is the responsibility of the supervisor to read and explain the manuals, safety practices, and operating instructions to the operator.

Safe operation of equipment requires that the operator wear approved Personal Protective Equipment (PPE) for the job conditions when attaching, operating, servicing, and repairing the equipment. PPE is designed to provide operator protection and includes the following safety wear:

PERSONAL PROTECTIVE EQUIPMENT (PPE)

- Always Wear Safety Glasses
- Hard Hat
- Steel Toe Safety Footwear
- Gloves
- Hearing Protection
- Close Fitting Clothing
- Respirator or Filter Mask (depends on operating conditions) *OPS-U- 0002*

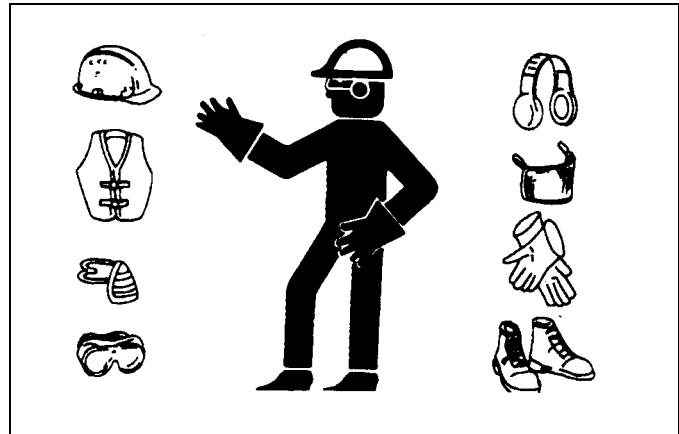

⚠ DANGER

DO NOT use drugs or alcohol immediately before or while operating the Tractor and Implement. Drugs and alcohol will affect an operator's alertness and coordination and therefore affect the operator's ability to operate the equipment safely. Before operating the Tractor or Implement, an operator on prescription or over-the-counter medication must consult a medical professional regarding any side effects of the medication that would hinder their ability to operate the Equipment safely. NEVER knowingly allow anyone to operate this equipment when their alertness or coordination is impaired. Serious injury or death to the operator or others could result if the operator is under the influence of drugs or alcohol. (SG-27)

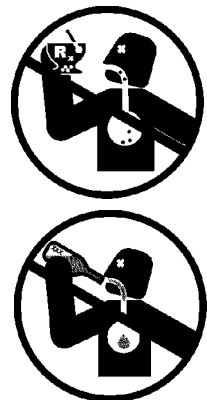

OPERATION

3. TRACTOR REQUIREMENTS

In addition to tractor horsepower and size required to operate the boom unit, the tractor must also be properly equipped to provide operator protection, to alert approaching vehicle drivers of the tractor's presence, and to ensure tractor stability when mowing with the boom fully extended.

Tractor Requirements and Capabilities

- Certified approved Roll-Over Protective Structure (ROPS) or ROPS cab and seat belt.
- Tractor Safety Devices Slow Moving Vehicle (SMV) emblem, lighting, PTO master shield
- Tractor Horsepower-Minimum Rear INT 88" 60hp, Rear INT 96" 60hp
- Drawbar 14" length-measured from end of PTO shaft to hitch pin hole, rated to carry mower tongue weight, safety chain attachment point
- Hydraulics 4-Spool Valve & 2-Spool Valve with Detent Position
- Power Take Off 540 RPM

3.1 ROPS and Seat Belt

The tractor must be equipped with a Roll-Over-Protective-Structure (ROPS) (tractor cab or roll-bar) and seat belt to protect the operator from falling off the tractor, especially during a roll over where the driver could be crushed and killed. Only operate the tractor with the ROPS in the raised position and seat belt fastened. Tractor models not equipped with a ROPS and seat belt should have these life saving features installed by an authorized dealer. *OPS-U- 0003*



Operate this Equipment only with a Tractor equipped with an approved roll-over-protective system (ROPS). Always wear seat belts. Serious injury or even death could result from falling off the tractor--particularly during a turnover when the operator could be pinned under the ROPS. (SG-7)



3.2 Tractor Safety Devices

If transporting or operating the tractor and implement near a public roadway, the tractor must be equipped with proper warning lighting and a Slow Moving Vehicle (SMV) emblem which are clearly visible from the rear of the unit. Lights and a SMV emblem must be equipped directly on implements if the visibility of the tractor warning signals are obscured.

Maintain all manufacturer equipped safety shields and guards. Always replace shields and guards that were removed for access to connect, service, or repair the tractor or implement. Never operate the tractor PTO with the PTO master shield missing or in the raised position. *OPS-U- 0004*

3.3 Tractor Horsepower

The horsepower required to operate the mower depends on many factors including the vegetation to be cut, terrain condition, operator experience, and condition of the mower and tractor. For most mowing condition, the Rear INT 88" & 96" mowers require a tractor with at least 60HP. Operating the mower with a tractor that does not have adequate power may damage the tractor engine.

OPERATION

⚠ DANGER

DO NOT use a PTO adapter to attach a non-matching Implement driveline to a Tractor PTO. Use of an adapter can double the operating speed of the Implement resulting in excessive vibration, thrown objects, and blade and implement failure. Adapter use will also change the working length of the driveline exposing unshielded driveline areas. Serious bodily injury and/or equipment failure can result from using a PTO adapter. Consult an authorized dealer for assistance if the Implement driveline does not match the Tractor PTO.

(S3PT-14)

⚠ WARNING

Never operate the Tractor and Mower if the Implement input driveline is directly connected to the Tractor transmission. Tractor braking distances can be substantially increased by the momentum of the rotating Mower blades driving the Tractor transmission even though the Tractor clutch has been disengaged. Install an over running clutch between the Tractor PTO and the Mower driveline to prevent this potentially dangerous situation. (S3PT-16)

4. GETTING ON AND OFF THE TRACTOR

Before getting onto the tractor, the operator must read and completely understand the implement and tractor operator manuals. If any part of either manual is not completely understood, consult an authorized dealer for a complete explanation. *OPS-U- 0007*

⚠ WARNING

Do not mount or dismount the Tractor while the tractor is moving. Mount the Tractor only when the Tractor and all moving parts are completely stopped. (SG-12)



4.1 Boarding the Tractor

Use both hands and equipped handrails and steps for support when boarding the tractor. Never use control levers for support when mounting the tractor. Seat yourself in the operator's seat and secure the seat belt around you.

Never allow passengers to ride on the tractor or attached equipment. Riders can easily fall off and be seriously injured or killed from falling off and being ran over. It is the operator's responsibility to forbid all extra riders at all times. *OPS-U- 0008*

⚠ DANGER

Never allow children to operate, ride on, or come close to the Tractor or Implement. Usually, 16-17 year-old children who are mature and responsible can operate the implement with adult supervision, if they have read and understand the Operator's Manuals, been trained in proper operation of the tractor and Implement, and are physically large enough to reach and operate the controls easily. (SG-11)



OPERATION



Never allow children or other persons to ride on the Tractor or Implement. Falling off can result in serious injury or death. (SG-10)



Do not mount or dismount the Tractor while the tractor is moving. Mount the Tractor only when the Tractor and all moving parts are completely stopped. (SG-12)



4.2 Dismounting the Tractor

Before dismounting the tractor, idle the tractor engine down, disengage the head and retract the boom arm to the transport position. Park the tractor on a level surface, place the transmission in neutral and set the parking brake. Shut down the tractor engine, remove the key, and wait for all motion to come to a complete stop before exiting the operator's seat. NEVER leave the seat until the tractor, its engine, and mower head movement have come to a complete stop.

Use hand rails and extra steps when exiting the tractor. Be careful of your step and use extra caution when mud, ice, snow, and other matter has accumulated on the steps and handrails. Never rush or jump off the tractor. OPS-B- 0002



BEFORE leaving the tractor seat lower the implement, set the parking brake and/or set the tractor transmission in parking gear, disengage the PTO, stop the engine, remove the key, and wait for all moving parts to stop. Place the tractor shift lever into a low range or parking gear to prevent the tractor from rolling. Never dismount a Tractor that is moving or while the engine is running. Operate the Tractor controls from the tractor seat only. (SG-9)

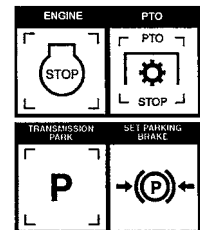

OPERATION

5. STARTING THE TRACTOR

The operator must have a complete understanding of the placement, function, and operational use of all tractor controls before starting the tractor. Review the tractor operator's manual and consult an authorized dealer for tractor operation instructions if needed.

Essential Tractor Controls:

- Locate the ignition key/switch
- Locate the engine shut off control
- Locate the hydraulic control levers
- Locate the light control lever
- Locate the brake pedals and clutch
- Locate the PTO control
- Locate the 3 point hitch control lever
- Locate the boom operating controls (joystick or valve bank)

Before starting the tractor ensure the following:

- Conduct all pre-start operation inspection and service according to the tractor operator's manual.
- Make sure all guards, shields, and other safety devices are securely in place.
- The parking brake is on.
- The tractor transmission levers are in park or neutral.
- The boom operating controls are in the neutral and off position.
- The PTO control lever is disengaged.
- The hydraulic remote control levers are in the neutral position.

Refer to the tractor owner's manual for tractor starting procedures. Only start the tractor while seated and belted in the tractor operator's seat. Never bypass the ignition switch by short circuiting the starter solenoid. After the tractor engine is running, avoid accidental contact with the tractor transmission to prevent sudden and unexpected tractor movement. *OPS-B- 0003*



Never run the Tractor engine in a closed building or without adequate ventilation. The exhaust fumes can be hazardous to your health. (SG-23)



Start tractor only when properly seated in the Tractor seat. Starting a tractor in gear can result in injury or death. Read the Tractor operators manual for proper starting instructions. (SG-13)



6. CONNECTING THE MOWER TO THE TRACTOR

Use extreme caution when connecting the mower to the tractor. The mower should be securely resting at ground level or setting on blocks. Keep hands and feet from under the mower deck and clear of pinch points between the tractor hitch arms and mower pins. *OPS-R-0001*

OPERATION



Always shut the Tractor completely down, place the transmission in park, and set the parking brake before you or anyone else attempts to connect or disconnect the Implement and Tractor hitches. (S3PT-15)

6.1 Connecting the Mower A-Frame to the Tractor

1. Make sure the tractor is equipped with the correct PTO shaft. Change shafts if needed.
2. Shorten or remove the tractor drawbar to avoid interference when raising and lowering the mower.
3. Board the tractor and start the engine. Position the tractor to the mower with the 3-point lift arms positioned between the respective set of mower A-frame lift lugs. Note: Set the 3-point lift control to "Position Control" so that the lift arms maintain a constant height when attaching the mower. See the tractor Operator's Manual for correct settings when attaching 3-point equipment.
4. Turn off the tractor engine and dismount.
5. One lift arm at a time, align arm end hole between the set of A-frame lift lugs. Insert hitch pin through the lug and arm holes and insert retaining pin into hitch pin.
6. Walk around to opposite side and repeat procedure for remaining lift arm and hitch pin.
7. Extend or retract 3-point top link to align its end hole with the holes of the mower's top link. Insert the top link hitch pin and insert retaining pin into hitch pin.
8. Adjust any lower link check chains, guide blocks, or sway blocks to prevent the mower from swaying side to side and possible contact with tractor rear tires.



IMPORTANT: Scan this QR Code with your smart phone to link to the PAMI Safe Implement Hitching Manual for more information on correctly connecting agricultural tractors to implements. Or type in your internet browser the following web address: www.algqr.com/hme Ops-0008-MISC



OPERATION

7. SETTING THE MOWER

Properly setting the cutting height is essential for efficient and safe operation. A properly set mower will make a more uniform cut, distribute clippings more evenly, require minimal tractor work, and follow the contour of uneven terrain. **NOTE:** *Avoid very low cutting heights, striking the ground with the blades gives the most damaging shock loads and will cause damage to the mower and drive. Blades contacting the ground may cause objects to be thrown out from under the mower deck. Always avoid operating the mower at a height which causes the blades to contact the ground. OPS-U- 0010*



Never work under the Implement, the framework, or any lifted component unless the Implement is securely supported or blocked up to prevent sudden or inadvertent falling which could cause serious injury or even death. (SG-14)



OPERATION

7.1 Roller Height Adjustment

1. The mower's cutting height is set by positioning the roller assembly for each mower section. Each section must be set at the same height to ensure an even cut across the entire width of the mower.
2. Place the tractor and mower on a level surface and completely lower the mower to the ground.
3. Shut down the tractor, place the transmission in park, and set the parking brake before dismounting.
4. One section at a time, place lifting device (scissors jack or hydraulic jack) under center of cutter housing.
5. Remove hex nuts, washers and carriage bolts from bracket at each end of roller. Make certain that roller bracket is free to move once the fasteners are removed. A stuck roller could drop unexpectedly and cause injury.
6. Use lifting device to reposition cutter housing to desired cutting height. Align bracket holes with cutter housing, then reinstall hardware.
7. Lower cutter housing to the ground and remove lifting device.
8. Set cutting height according to procedures above for remaining two cutter sections. Make sure that all three rollers are set at the same height to ensure a even cut across the entire width of the mower.

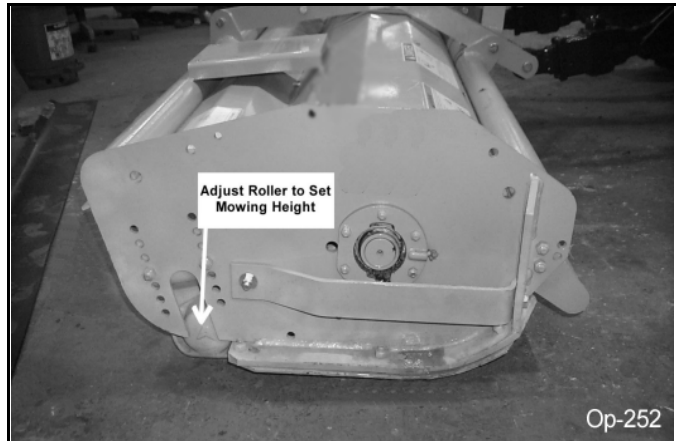

Op-252

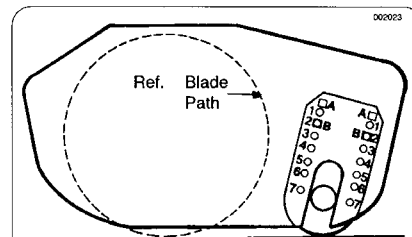

MOWER CUTTING HEIGHT ADJUSTMENT

DESIRED CUTTING HEIGHT (INCHES)	ADJUSTMENT BRACKET HOLE	MOWER END PLATE HOLE
1/2	B	2
1	A	1
1-1/2	B	3
2	A	2
2-1/2	B	4
3	A	3
3-1/2	B	5
4	A	4
4-1/2	B	6
5	A	5
5-1/2	B	7
6	A	6

Op- 253

Hydraulic Cylinder Priming

Hydraulic Cylinders must be filled with hydraulic oil before releasing the wing transport locks to lower the mower. Hydraulic cylinders and lines are filled by holding the valve control levers in the raised position until the cylinders fully extend then place the control lever in the float position. Repeat the process several more times to ensure wings are entirely supported by the hydraulic cylinders before releasing the transport locks and lowering the mower.

OPERATION

7.2 Leveling Deck

To Facilitate a safe and efficient mowing operation, the mower should be operated parallel to the ground at all times. Never operate if front or rear of mower is tilted upward. Objects may be discharged at high speeds causing possible injury or even death.

Adjust Top Link to level mower roller adjustment. Side Skid Shoes should always be parallel to ground throughout the full adjustment range. Adjust cutting height of machine by raising or lowering rear roller as specified in Operation Section.

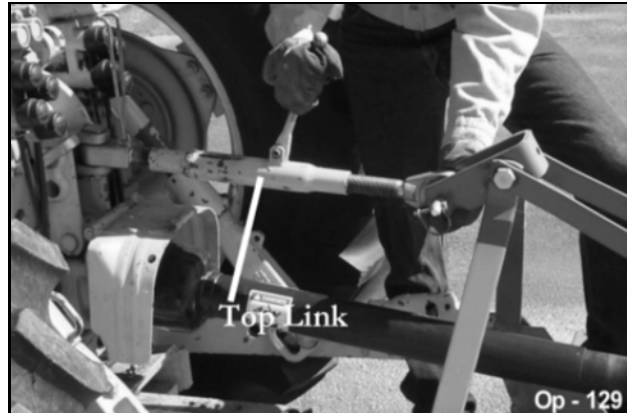

WARNING

Do not let the Blades turn when the Mower Deck is raised for any reason, including clearance or for turning. Raising the Mower deck exposes the Cutting Blades which creates a potentially serious hazard and could cause serious injury or even death from objects thrown from the Blades. (SRM-07)



8. DRIVELINE ATTACHMENT

The driveline yoke and tractor PTO shaft must be dirt free and greased for attachment.

To connect the mower driveline to the tractor PTO output shaft, pull the driveline yoke collar back and align the grooves and splines of the yoke with those of the PTO shaft. Push the driveline yoke onto the PTO shaft, release the locking collar, and position the yoke until the locking collar balls are seated onto the PTO shaft. Push and pull the driveline back and forth several times to ensure a secure attachment.

After the driveline is securely attached, place the tractor PTO master shield back in the operating position. OPS-R-0003



8.1 Driveline Length Check

WARNING

Before operating the Implement, check to make sure the Implement input driveline will not bottom out or become disengaged. Bottoming out occurs when the inner shaft penetrates the outer housing until the assembly becomes solid-it can shorten no more. Bottoming out can cause serious damage to the Tractor PTO by pushing the PTO into the Tractor and through the support bearings or downward onto the PTO shaft, breaking it off. A broken driveline can cause personal injury. (S3PT-18)

OPERATION

When fitting the mower to the tractor, the telescoping driveline must be inspected to ensure that at its most compressed position, the profiles do not “bottom out”, and when at its farthest extended position, there is sufficient engagement between the profiles to operate safely. At its shortest length, there must be at least a 1” clearance between each profile end and opposite profile universal joint. At its farthest operating extension, a minimum profile engagement of 12” must be maintained.

“Bottoming Out” Check Procedure

- Disconnect driveline from the tractor and slide the profiles together until fully compressed.
- Place a mark on the inner shield 1/8” from the end of the outer shield and reattach the driveline to the PTO Shaft.
- With the **PTO NOT TURNING**, slowly drive the tractor with mower attached through the sharpest turn possible and watch shaft movement. With the **PTO NOT TURNING**, slowly drive the tractor with the mower attached through the most severe terrain conditions expected and watch shaft movement.
- If the distance between the mark and the outer shield becomes less than 2” at any point there is a potential problem bottoming out the driveline and the driveline should be shortened.
OPS-F-0001

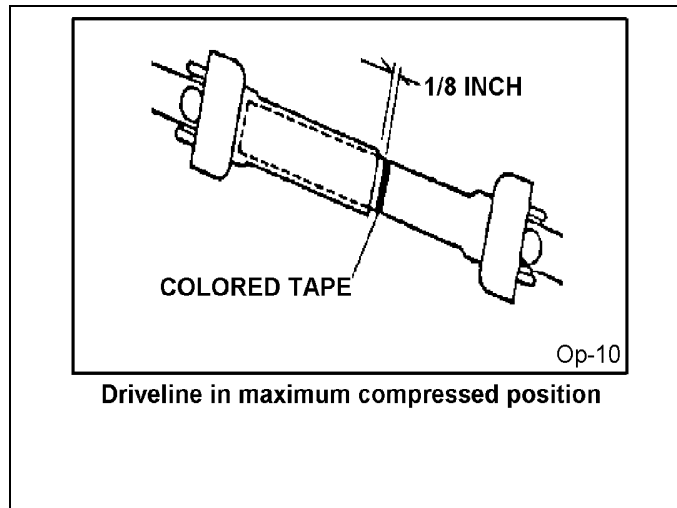

OPERATION

Shorten the driveline profiles as follows:

- Remove the driveline from the tractor.
- Position the mower to the point with the shortest distance between the tractor PTO shaft and cutter gearbox. Shut down the tractor and securely block the mower in this position.
- Pull driveline apart and reattach yoke to PTO shaft.
- Hold driveline sections parallel to one another and measure back 1" from yoke of each shaft and place mark on opposite section. Cut this length off with a saw.
- Round off all sharp edges and debur.
- Thoroughly grease then reinstall the driveline.
- Recheck for proper operation.

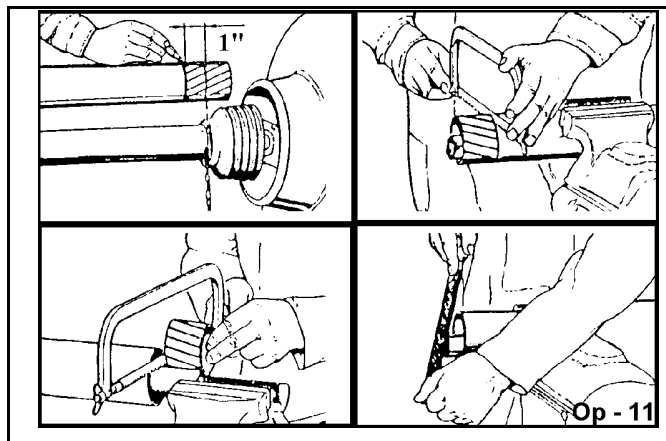

Engagement Check Procedure

- With the driveline attached, position the mower to the point where the telescoping driveline is at its maximum extension. Completely shut down the tractor and secure in position.
- Mark the inner driveline shield 1/8" from the end of the outer shield.
- Disconnect the driveline from the tractor and separate the two driveline halves.
- Measure the distance from the mark to the end of the inner profile. This length is the amount the driveline profiles were engaged.
- If the engaged length is less than 12" the shaft is considered too short and should be replaced with a longer shaft. Consult an authorized dealer to purchase the required driveline length.

NOTE: If the driveline cannot be shortened and still maintain the required profile engagement, the operator must be made aware of terrain conditions and avoid situations which pose a potential problem to avoid damaging the driveline. OPS-F-0002

IMPORTANT: Scan this QR Code with your smart phone to link to the ADMA Driveline Safety Manual for more information on the safe use of a driveline during normal operation and maintenance. Or type in your internet browser the following web address: www.algqr.com/dme Ops-0009-MISC



9. PRE-OPERATION INSPECTION AND SERVICE

Before each use, a pre-operation inspection and service of the implement and tractor must be performed. This includes routine maintenance and scheduled lubrication, inspecting that all safety devices are equipped and functional, and performing needed repairs. DO NOT operate the unit if the pre-operation inspection reveals any condition affecting safe operation. Perform repairs and replacement of damaged and missing parts as soon as noticed. By performing a thorough pre-operation inspection and service, valuable down time and repair cost can be avoided. OPS-U-0029

OPERATION



Always disconnect the main PTO Driveline from the Tractor before performing service on the Mower. Never work on the Mower with the tractor PTO driveline connected and running. Blades or Drivelines could turn without warning and cause immediate entanglement, injury or death. (SRM-3)



DO NOT allow any person under a folded wing unless wing is securely locked up or supported. **DO NOT** approach the Implement unless the Tractor is turned off and all motion has ceased. Never work under the frame work, or any lifted component unless the implement is securely supported or blocked up. A sudden or inadvertent fall by any of these components could cause serious injury or even death. (STI-03)



Periodically inspect all moving parts for wear and replace when necessary with authorized service parts. Look for loose fasteners, worn or broken parts, and leaky or loose fittings. Make sure all pins have cotter pins and washers. Serious injury may occur from not maintaining this machine in good working order. (SG-21)

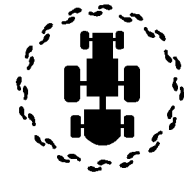

OPERATION

9.1 Tractor Pre-Operation Inspection/Service

Refer to the tractor operator's manual to ensure a complete pre-operation inspection and scheduled service is performed according to the manufacturers recommendations. The following are some of the items that require daily service and inspection:

- Tire condition/air pressure
- Wheel lug bolts
- Steering linkage
- PTO shield
- SMV sign is clean and visible
- Tractor's lights are clean and functional
- Tractor Seat belt is in good condition
- Tractor ROPS is in good condition
- ROPS is in the raised position
- No tractor oil leaks
- Radiator free of debris
- Engine oil level and condition
- Engine coolant level and condition
- Power brake fluid level
- Power steering fluid level
- Fuel condition and level
- Sufficient lubrication at all lube points
- Air filter condition OPS-U-0030



9.2 Mower Pre-Operation Inspection/Service

Before each mower use, a complete inspection and service is required to ensure the mower is in a good and safe working condition. Damaged and/or broken parts should be repaired and/or replaced immediately. To ensure the mower is ready for operation, conduct the following. OPS-R-0007



All Safety Shields, Guards and Safety devices including (but not limited to) - the Deflectors, Steel Guards, Gearbox Shields, PTO integral shields, and Retractable Door Shields should be used and maintained in good working condition. All safety devices should be inspected carefully at least daily for missing or broken components. Missing, broken, or worn items must be replaced at once to reduce the possibility of injury or death from thrown objects, entanglement, or blade contact. (SFL-5)

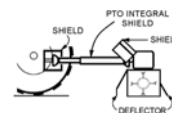

Replace bent or broken blades with new blades. NEVER ATTEMPT TO STRAIGHTEN, WELD, OR WELD HARDFACING ON BLADES SINCE THIS WILL LIKELY CRACK OR OTHERWISE DAMAGE THE BLADE WITH SUBSEQUENT FAILURE AND POSSIBLY CAUSE SERIOUS INJURY FROM THROWN BLADES. (SGM-10)

OPERATION

The operator's manual and safety signs affixed on the unit contain important instructions on the safe and proper use of the equipment. Maintain these important safety features on the implement in good condition to ensure the information is available to the operator at all times.

- Ensure the manual canister is secured to the equipment with the operator's manual inside.
- Ensure all safety signs are in place and legible. Replace missing, damaged, and illegible decals. *OPS-U- 0011*

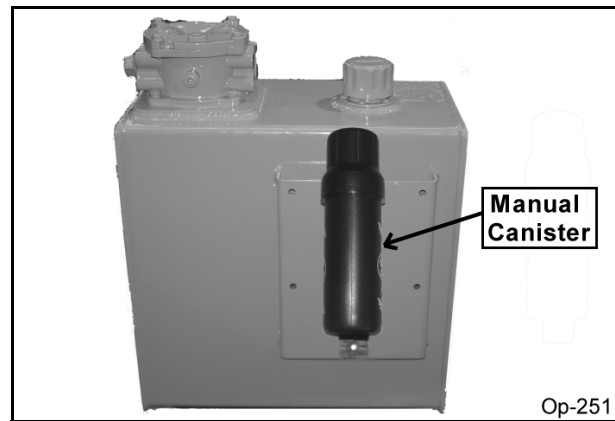

- Check that the main driveline securely attached to the tractor and the locking collar is seated in the groove of the PTO Shaft.
- Ensure wing hydraulics are secure at both ends.
- Ensure the mower hitch is securely attached to the tractor drawbar with a proper size bolt and secured nut.
- Ensure that a properly rated safety tow chain is equipped securing the mower to the tractor. *OPS-F- 0003*



OPERATION

OPERATION

- Ensure rubber deflectors are in position and not damaged. Replace worn, broken, and missing sections immediately.
- Ensure the rollers are in good condition and rotate freely.
- Ensure the driveline integral shield is in good condition and rotate freely.
- Inspect that all bolts and screws are in position and are properly torqued. *OPS-F- 0004*



- Inspect the condition of the wings and rear section drive belts.
- Ensure the slip clutch (rear mower section only) is properly adjusted and the friction plates are not frozen together. Reference the Maintenance Section for proper slip clutch maintenance.
- Ensure the slip clutch shield and drive belts shields are in place and in good repair.
- Ensure the tractor PTO master shield is in place, lowered and in good condition. *OPS-F- 0005*



- Inspect oil level in gearbox and replenish if needed. A low oil level is a warning sign that the gearbox may be cracked or its seal is damaged and needs to be replaced.
- Check the oil level in tank and replenish if need. **NOTE:** Do not fill the tank with oil above the level of the sight gauge. Over filling the tank with oil after initial filling may result in oil being discharged through the air filter on the top of the hydraulic tank.
- Perform scheduled lubrication as specified in the maintenance section. *OPS-F- 0006*

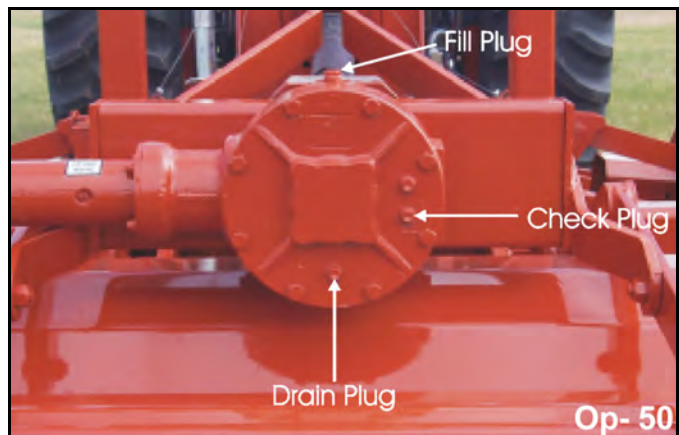

OPERATION

- Inspect cutter knives and knife pins for looseness and excessive wear. Make sure the mower is securely blocked up before crawling beneath. Replace damaged, worn, and missing knives as complete sets to maintain cuttershaft balance.
- Remove any grass or other debris which may be wrapped around the cuttershafts.
- Inspect the condition of deck skid shoes and hardware. *OPS-F-0007*



OPERATION

OPERATION

Flail Mower PRE-OPERATION Inspection



Mower ID# _____

Make: _____

Date: _____

Shift: _____

IMPORTANT: Scan this QR Code for an electronic copy of this inspection sheet.

Inspection Sheet



www.algqr.com/fmi



Before conducting the inspection, make sure the tractor engine is off, all rotation has stopped and the tractor is in park with the parking brake engaged. Make sure the mower is resting on the ground or securely blocked up and all hydraulic pressure has been relieved.

Item	Condition at Start of Shift	Specific Comments if not O.K.
FLAIL MOWER		
The Operator's Manual is in the canister on the mower		
All safety decals are in place and legible		
The hitch connection bolts & pins are tight		
There are no cracks in hitch		
Their mower deck is clear of cut grass and debris		
The thrown object guard/deflectors are in place		
Their guards/deflectors are in good condition		
The driveline/gearbox shields are in good condition		
The driveline clutch is in good condition, not frozen		
The driveline tubes & u-joints have been lubricated		
The driveline yoke is securely attached to the PTO		
The gearbox oil level is full		
Blades are not broken, chipped, cracked or bent		
Blade shackles are in good condition with no cracks		
The blade pins are properly retained		
The skid shoes are in good condition & tight		
The rear roller is in good condition and turns freely		

Operator's Signature: _____

DO NOT OPERATE an UNSAFE TRACTOR or MOWER

OPERATION

Tractor PRE-OPERATION Inspection



Mower ID# _____ Make _____

Date: _____ Shift _____



Before conducting the inspection, make sure the tractor engine is off, all rotation has stopped and the tractor is in park with the parking brake engaged. Make sure the mower is resting on the ground or securely blocked up and all hydraulic pressure has been relieved.

OPERATION

Item	Condition at Start of Shift	Specific Comments if not O.K.
The flashing lights function properly		
The SMV Sign is clean and visible		
The tires are in good condition with proper pressure		
The wheel lug bolts are tight		
The tractor brakes are in good condition		
The steering linkage is in good condition		
There are no visible oil leaks		
The hydraulic controls function properly		
The ROPS or ROPS Cab is in good condition		
The seatbelt is in place and in good condition		
The 3-point hitch is in good condition		
The drawbar pins are securely in place		
The PTO master shield is in place		
The engine oil level is full		
The brake fluid level is full		
The power steering fluid level is full		
The fuel level is adequate		
The engine coolant fluid level is full		
The radiator is free of debris		
The air filter is in good condition		

Operator's Signature: _____

DO NOT OPERATE an UNSAFE TRACTOR or MOWER

This Inspection Form may be freely duplicated for extra copies.

OPERATION

10. DRIVING THE TRACTOR AND IMPLEMENT

Safe tractor transport requires the operator possess a thorough knowledge of the model being operated and precautions to take while driving with an attached implement. Ensure the tractor has the capacity to handle the weight of the implement and the tractor operating controls are set for safe transport. To ensure safety while driving the tractor with an attached implement, review the following. *OPS-U- 0012*



This Implement may be wider than the Tractor. Be careful when operating or transporting this equipment to prevent the Implement from running into or striking sign posts, guard rails, concrete abutments or other solid objects. Such an impact could cause the Implement and Tractor to pivot violently resulting in loss of steering control, serious injury, or even death. Never allow the Implement to contact obstacles. (S3PT-12)



Transport only at speeds where you can maintain control of the equipment. Serious accidents and injuries can result from operating this equipment at high speeds. Understand the Tractor and Implement and how it handles before transporting on streets and highways. Make sure the Tractor steering and brakes are in good condition and operate properly.



Before transporting the Tractor and Implement, determine the proper transport speeds for you and the equipment. Make sure you abide by the following rules:

Test the tractor at a slow speed and increase the speed slowly. Apply the Brakes smoothly to determine the stopping characteristics of the Tractor and Implement. As you increase the speed of the Tractor the stopping distance increases. Determine the maximum transport speed not to exceed 20 mph (30 kph) for transporting this equipment.

Test the equipment at a slow speed in turns. Increase the speed through the turn only after you determine that the equipment can be operated at a higher speed. Use extreme care and reduce your speed when turning sharply to prevent the tractor and implement from turning over. Determine the maximum turning speed for you and this equipment before operating on roads or uneven ground.

Only transport the Tractor and Implement at the speeds which allow you to properly control the equipment.

Be aware of the operating conditions. Do not operate the Tractor with weak or faulty brakes or worn tires. When operating down a hill or on wet or rain slick roads, the braking distance increases: use extreme care and reduce your speed. When operating in traffic always use the Tractor's flashing warning lights and reduce your speed. Be aware of traffic around you and watch out for the other guy. (SG-19)



OPERATION

10.1 Starting the Tractor

The procedure to start the tractor is model specific. Refer to the tractor operator's manual for starting procedures for your particular tractor. Consult an authorized dealer if the starting procedure is unclear. Ensure the 3-point control lever is in the lowered position and the PTO is disengaged before starting the tractor. OPS-U-0033



10.2 Brake and Differential Lock Setting

Make sure the tractor brakes are in good operating condition. Tractor brakes can be set to operate independently allowing single rear wheel braking action or locked together to provide simultaneous rear wheel braking. FOR MOST DRIVING AND OPERATING CONDITIONS, THE BRAKE PEDALS SHOULD BE LOCKED TOGETHER TO PROVIDE THE MOST EFFECTIVE BRAKING ACTION.

Always disengage the tractor differential lock when turning. When engaged the differential lock will prevent or limit the tractor from turning. During normal cutting conditions, locking the differential provides no benefit and should not be used. OPS-U-0013

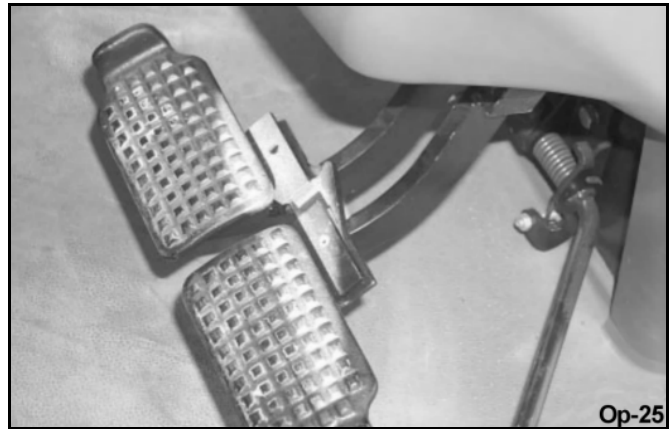

WARNING

Be aware of the operating conditions. Do not operate the Tractor with weak or faulty brakes. When operating down a hill or on wet or rain slick roads, the braking distance increases; use extreme care and reduce your speed in these conditions. When operating in traffic, always use the Tractor's flashing warning lights and reduce your speed. Be aware of traffic around you and watch out for the other guy.

OPERATION

OPERATION

11. Operating the Mower Wings

Raising to Transport Position

1. With tractor engine running, place ON/OFF switch(s) in "OFF" position and wait for cuttershaft(s) to stop rotating.
2. Pull LIFT control lever rearward until lift frame is as high as it will go.
3. Pull TILT control lever rearward until bracket on unit is above support bar on lift cylinder support. If unit is in the detent "FLOAT", it will take some effort to pull TILT lever from "FLOAT" position.
4. Push LIFT control lever forward enough to lower unit slowly. Bar on cylinder support must pass through bracket on unit as shown in **Figure 268**.
5. Make certain that all control levers are in "HOLD" position when transporting unit.

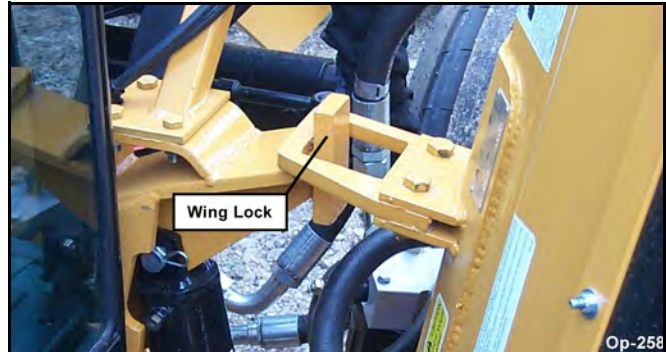

LEFT SIDE		RIGHT SIDE	
TILT CYL	LIFT CYL	LIFT CYL	TILT CYL
FLOAT	FLOAT	FLOAT	FLOAT
▲	▲	▲	▲
OUT	& DOWN	& DOWN	OUT
▲	▲	▲	▲
HOLD	HOLD	HOLD	HOLD
▼	▼	▼	▼
IN	UP	UP	IN

NOTE: Lift and Tilt cylinder rods may be adjusted to provide proper transport bracket to support bar clearance.

Loosen rod end clamp.

Shorten stroke on LIFT cylinder to raise lift frame.
Lengthen stroke on LIFT cylinder to lower lift frame.

and/or

Shorten stroke on TILT cylinder to move transport bracket closer to support bar. Lengthen stroke on TILT cylinder to move transport bracket away from support bar.

Once sufficient clearance is obtained, tighten rod end clamp.

The mower's center of gravity is raised making the mower more prone to tipping when the wings are in the raised position. Use extreme caution when towing the mower in the transport position and avoid uneven terrain which could upset the mower.



OPERATION



When the Wings are folded for transport, the center of gravity is raised and the possibility of overturn is increased. Drive slowly and use extreme caution when turning on hillsides. Overturning the Implement could cause the Implement to overturn the Tractor and vice versa resulting in serious injury or even death. Never fold wings on a hillside...the Implement or unit may overturn. (STI-02)

Lowering into Operating Position

Ensure that ON/OFF switch(es) is (are) in "OFF" position. With tractor engine running, pull LIFT control lever rearward until bracket on cutter unit clears support bar on lift cylinder support. Push TILT control lever forward until cutter unit is level with ground. Push LIFT lever forward enough to slowly lower unit until it touches ground, then push both levers forward to "FLOAT" position.



Op-260



The mower head will start running when lowered if the mower ON/OFF switch is in the ON position. Make sure the SWITCH is in the OFF position before lowering mower wing(s). (SFL-10)

NOTE: For best mowing results and longer roller life, both LIFT and TILT levers should be in "FLOAT" position while mowing.

It takes some effort to pull TILT lever from "FLOAT" position because of detent spring.

The mower must be operated with the cutter sections fully lowered and the hydraulic control lever in the float detent to ensure the mower follows the contour of the ground and to prevent sections from creeping up. NEVER attempt to raise the mower while the mower is operating.



MntP-FL-0021

LEFT SIDE		RIGHT SIDE	
TILT CYL	LIFT CYL	LIFT CYL	TILT CYL
FLOAT	FLOAT	FLOAT	FLOAT
▲	▲	&	▲
OUT	DOWN	DOWN	OUT
▲	▲	▲	▲
HOLD	HOLD	HOLD	HOLD
▼	▼	▼	▼
IN	UP	UP	IN

OPERATION

11.1 Engaging and Disengaging the Power Take Off (PTO) and Wings

Before engaging the PTO, make certain that the area is clear of bystanders and passersby. The implement must be lowered to the mowing position. NEVER engage the PTO with the implement in the raised position. Set the tractor engine speed at approximately 1,000 RPM before engaging the PTO. Shift the PTO control to the on position.

To start the wings, make sure they are in the lowered position (refer to Lowering Wings into Operating Position of the operation section) and PULL the start/stop button(s) to start the wing motor(s) and slowly increase the engine speed until the PTO is operating at the rated speed. If you hear unusual noises or see or feel abnormal vibrations, lower the engine RPM's, disengage the PTO and PUSH the wing start/stop button(s) to stop the wing motor(s). Inspect the implement to determine the cause of the noise or vibration and repair the abnormality.



Do not let the Blades turn when the Mower Deck is raised for any reason, including clearance or for turning. Raising the Mower deck exposes the Cutting Blades which creates a potentially serious hazard and could cause serious injury or even death from objects thrown from the Blades. (SRM-07)



Do not put hands or feet under mower decks. Blade Contact can result in serious injury or even death. Stay away until all motion has stopped and the decks are securely blocked up. (SGM-09)



OPERATION

11.2 Driving the Tractor and Implements

Start off driving at a slow speed and gradually increase your speed while maintaining complete control of the tractor and units. Moving slowly at first will also prevent the tractor from rearing up and loss of steering control. The tractor should never be operated at speeds that cannot be safely handled or which will prevent the operator from stopping quickly during an emergency. If the power steering or engine ceases operating, stop the tractor immediately as the tractor will be difficult to control.

Drive the tractor with the 3-Point lift arms in the raised position and lock the control lever in the transport detent position to prevent damage to the mower driveline and tongue when turning.

Perform turns with the tractor and units at slow speeds to determine how the tractor with an attached blade or rake handles a turn. Determine the safe speed to maintain proper control of the tractor when making turns. When turning with a towed implement, the overall working length of the unit is increased. Allow additional clearance for the units when turning.

To avoid overturns, drive the tractor with care and at safe speeds, especially when operating over rough ground, crossing ditches or slopes, and turning corners. Tractor wheel tread spacing should be increased when working on inclines or rough ground to reduce the possibility of tipping.

Use extreme caution when operating on steep slopes. Keep the tractor in a low gear when going downhill. **DO NOT** coast or free-wheel downhill.
OPS-F- 0009



OPERATION

11.3 Crossing Ditches and Steep Inclines

When crossing ditches with steep banks or going up sharp inclines, it is possible that the main driveline inner profile will penetrate into the outer housing to its maximum depth until the assembly becomes solid (driveline is at its extreme shortest length). This type of abusive operation can cause serious damage to the tractor and mower drive by pushing the PTO into the tractor and through the support bearings or downward onto the PTO shaft, breaking it off.

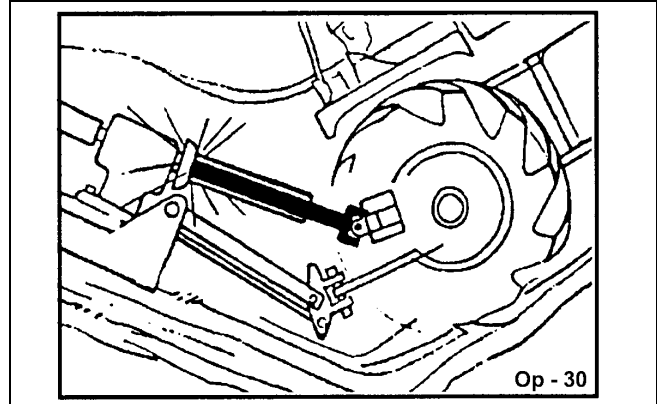

WARNING

Damage resulting from over-collapse of the driveline's inner profile and its outer housing may allow the driveline to come loose from the Tractor which could cause bodily injury to the operator or bystanders and/or extensive damage to the Tractor or Implement. OPS-R-0020

When confronted with an incline or ditch, do not approach from an angle which is perpendicular or straight on as damaged to over collapse of the driveline may occur.

When crossing such terrain, the implement should be fully lowered for a lower center of gravity and added stability. OPS-R-0021

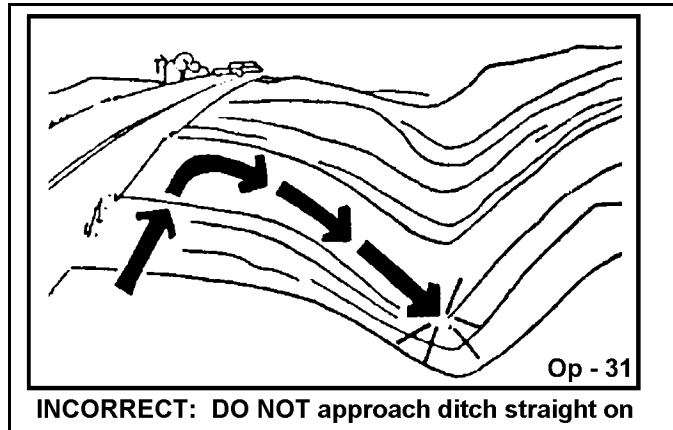

OPERATION

Inclines and ditches should be approached along a line which is at an angle as shown. This type of path will reduce the possibility of over-collapse of the driveline and resulting damage. If the gradient is so steep that such an approach increases the possibility of a tractor roll-over, select an alternate crossing path.

When operating the tractor and mower across slopes and inclines, through ditches, and other uneven terrain conditions, it is important to maintain sufficient deck to ground clearance. Blade contact with the ground may cause soil, rocks and other debris to be thrown out from under the mower resulting in possible injury and/or property damage. Ground contact also produces a severe shock load on the mower drive and to the mower blades resulting in possible damage and premature wear.
OPS-R-0022

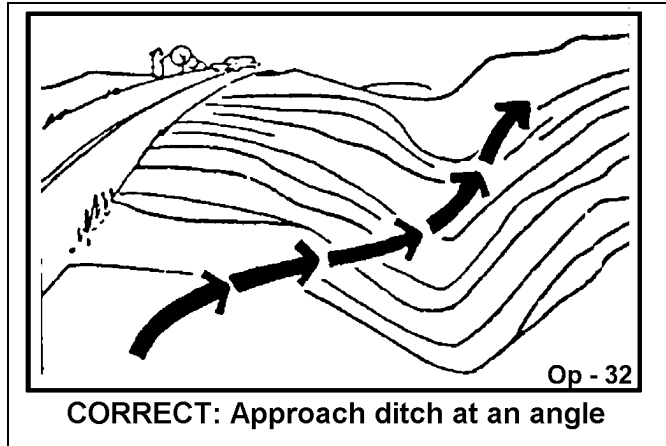

OPERATION

12. OPERATING THE TRACTOR AND IMPLEMENT

THE OPERATOR MUST COMPLETELY UNDERSTAND HOW TO OPERATE THE TRACTOR AND IMPLEMENT AND ALL CONTROLS BEFORE ATTEMPTING TO OPERATE. The operator must read and understand the Safety and Operation Sections of the implement and tractor operator's manuals. These manuals must be read and explained to any operator who cannot read. Never allow someone to operate the implement and tractor without complete operating instructions.

Before starting any operation, the operator must become familiar with the area to be worked in and any obstacles and hazards contained within to ensure safety to the operator, bystanders, and equipment. Special attention should be paid to foreign debris, rough terrain, steep slopes, and passersby and animals in the area.
OPS-U-0015



Extreme care should be taken when operating near loose objects such as gravel, rocks, wire, and other debris. Inspect the area before mowing. Foreign objects should be removed from the site to prevent machine damage and/or bodily injury or even death. Any objects that cannot be removed must be clearly marked and carefully avoided by the operator. Stop mowing immediately if blades strike a foreign object. Repair all damage and make certain rotor or blade carrier is balanced before resuming mowing. (SGM-05)



OPERATION

WARNING

Many varied objects, such as wire, cable, rope, or chains, can become entangled in the operating parts of the mower head. These items could then swing outside the housing at greater velocities than the blades. Such a situation is extremely hazardous and could result in serious injury or even death. Inspect the cutting area for such objects before mowing. Remove any like object from the site. Never allow the cutting blades to contact such items.

(SGM-06)

12.1 Foreign Debris Hazards

Before mowing, inspect the area to make sure there are no foreign objects that the mower blades could hit or become entangled with. Remove all foreign objects and debris. If objects are too big to remove, mark them clearly and be sure to prevent the mower blades from contacting them.

If you hit a solid object or foreign debris, stop the mower and tractor at once. Immediately idle the engine speed and disengage the PTO. Wait for all mower rotating motion to stop, then raise the mower and move the tractor and implement off the object. Inspect the area and remove, or mark the location of the debris. Inspect the condition of the mower and make any needed repairs immediately. Make sure the blades are not damaged and the carrier is balanced before resuming operation.



Op - 33

Always wear your seat belt securely fastened and only operate the tractor and mower with the ROPS in the raised position. If the tractor or mower hits a tree stump, rock, or bump, a sudden movement could throw you off of the seat and under the tractor and/or mower. The seat belt is your best protection from falling off the tractor and the ROPS provides protection from being crushed during a tractor roll-over. OPS-F-0010



Op-266

12.2 Bystanders/Passersby Precautions

If a bystander comes within 300 feet of the tractor while the mower is being operated, stop the tractor at once, idle the engine and disengage the PTO. Do not engage the PTO again until all bystanders are well past the 300 foot distance. OPS-R-0024

OPERATION

DANGER

Flail Mowers are capable under adverse conditions of throwing objects for great distances (300 feet or more) and causing serious injury or death. Follow safety messages carefully.



STOP MOWING IF PASSERSBY ARE WITHIN 300 FEET UNLESS:

- Front and Rear Deflectors, Chain Guards, or Bands are installed and in good, workable condition;
- Mower sections or Wings are running close to and parallel to the ground without exposed Blades;
- All areas have been thoroughly inspected and all foreign material such as rocks, cans, glass, and general debris has been removed.

NOTE: *Where there are grass and weeds high enough to hide debris that could be struck by the blades, the area should be: inspected and large debris removed, mowed at an intermediate height, inspected closely with any remaining debris being removed, and mowed again at desired final height. (This will also reduce power required to mow, reduce wear and tear on the Mower drivetrain, spread cut material better, eliminate streaking, and make the final cut more uniform.)* (SFL-6)

12.3 PTO RPM and Ground Speed

Ground speed for mowing will depend upon the height, type, and density of vegetation to be cut. Recommended speed for efficient mower performance is between 2 and 5 mph(3-8 kph). Operate the mower at its full rated PTO speed to maintain blade speed for a clean cut. Refer to the tractor operator's manual or the tractor instrument panel for the engine speed and gear to provide the required PTO and desired ground speed. Make sure that the mower is operating at its full rated speed before entering the vegetation to be cut. If it becomes necessary to temporarily regulate engine speed, increase or decrease the throttle gradually.

Ground speed is achieved by transmission gear selection and not by the engine operating speed. The operator may be required to experiment with several gear range combinations to determine the best gear and range which provides the most ideal performance from the mower and most efficient tractor operation. As the severity of cutting conditions increase, the ground speed should be decreased by selecting a lower gear to maintain the proper operating PTO speed. OPS-R-0025

WARNING

Do not exceed the rated PTO speed for the Implement. Excessive PTO speeds can cause Implement driveline or blade failures resulting in serious injury or death. (SG-26)

WARNING

Mow at the speed that you can safely operate and control the tractor and mower. The correct mowing speed depends on terrain condition and grass type, density, and height of cut. Normal ground speed range is from 2 to 5 mph(3-8 kph). Use slow mowing speeds when operating on or near steep slopes, ditches, drop-offs, overhead obstructions, power lines, or when debris and foreign objects are to be avoided. (SGM-07)

OPERATION

12.4 Operating the Mower

Only operate the mower from the tractor operator's seat with the seatbelt securely fastened. The tractor must be equipped with a ROPS in the raised position or a ROPS cab.

The mower is designed to cut vegetation up to 1-1/2" (38mm) in diameter. Sharp blades will produce a cleaner cut and require less power. Travel at a speed that allows the mower sufficient time to cut through the vegetation and maintain the PTO operating speed to prevent overloading the mower and tractor. Choose a driving pattern that provides the maximum pass length and minimizes turning.

Under certain conditions, tractor tires may roll some grasses down preventing them from being cut at the same height as the surrounding area. When this occurs, reduce the tractor ground speed while maintaining the operating speed of the mower. A slower ground speed will permit grasses to at least partially rebound and be cut. Taking a partial cut and/or reversing the direction of travel may also help produce a cleaner cut.

Avoid mowing in the reverse direction when possible. In situations where the mower must be backed to access areas to be cut, make sure there are no persons or other foreign debris behind the mower before mowing in reverse. When mowing in reverse, operate the tractor and mower at a reduced ground speed to ensure tractor and mower control is maintained. *OPS-R-0026*



Do not mow with two machines in the same area except with Cab tractors with the windows closed. (SGM-11)



Mow only in conditions where you have clear visibility in daylight or with adequate artificial lighting. Never mow in darkness or foggy conditions where you cannot clearly see at least 300 feet (90 m) in front and to the sides of the tractor and mower. Make sure that you can clearly see and identify passersby, steep slopes, ditches, drop-offs, overhead obstructions, power lines, debris and foreign objects. If you are unable to clearly see these type of items discontinue mowing. (SGM-1)



Avoid mowing in reverse direction when possible. Check to make sure there are no persons behind the mower and use extreme care when maneuvering in reverse. Mow only at a slow ground speed where you can safely operate and control the tractor and mower. Never mow an area that you have not inspected and removed debris or foreign material. (SGM-08)

OPERATION



Follow these guidelines to reduce the risk of equipment and grass fires while operating, servicing, and repairing the Mower and Tractor:



- Equip the Tractor with a fire extinguisher in an accessible location.
- Do Not operate the Mower on a Tractor with an underframe exhaust.
- Do Not smoke or have an open flame near the Mower and Tractor.
- Do Not drive into burning debris or freshly burnt areas.
- Ensure slip clutches are properly adjusted to prevent excessive slippage and plate heating.
- Never allow clippings or debris to collect near drivelines, slip clutches, and gearboxes. Periodically shut down the Tractor and Mower and clean clippings and collected debris from the mower deck. (SGM-12)

12.5 Shutting Down the Implement

To shut down the implement, first bring the tractor to a complete stop. Then slow down the implement by reducing the engine speed before disengaging the PTO. Push the stop button to disengage the wings and wait for all motion to stop before proceeding to drive or shut down the tractor.



Park the tractor on a level surface, place the transmission in park or neutral and apply the parking brake, lower the attached implement to the ground, shut down the engine, remove the key, and wait for all motion to come to a complete stop before exiting the tractor. OPS-F- 0011



OPERATION

OPERATION

13. DISCONNECTING THE MOWER FROM THE TRACTOR

Before disconnecting the mower, the PTO must be disengaged and all motion at a complete stop. Move the mower to a level storage location and lower both wings to the ground. If the mower will be stored with the sections in the raised position, be sure that the locks are engaged. If the mower is not resting securely on the ground, block the mower up securely before attempting to disconnect it from the tractor. Use extreme care to keep feet and hands from under the mower and clear of any pinch points. *OPS-F-0012*



After disconnecting the 3 lift points, remove the mower driveline from the tractor PTO shaft. Lay the driveline down carefully to avoid damaging the driveline or its shield. Do not let the driveline fall into mud or dirt, which can contaminate the bearing and shorten the life of the driveline. *OPS-F-0013*

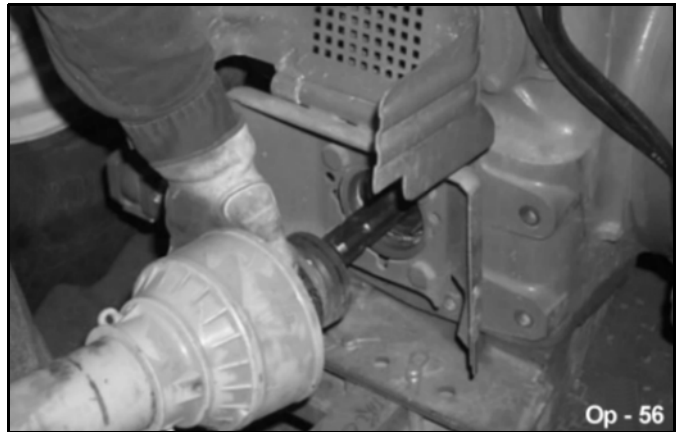

⚠ DANGER

Never work under the Implement, the framework, or any lifted component unless the Implement is securely supported or blocked up to prevent sudden or inadvertent falling which could cause serious injury or even death. (SG-14)



OPERATION

MOWER STORAGE

It is recommended that the mower be stored with the center section and both wings fully lowered to ground level. If the mower is stored with the wings in the raised position, select a level area and install wing transport braces to prevent the wings from falling BEFORE disconnecting the mower hitch from the tractor.

Properly preparing and storing the mower at the end of the season is critical to maintaining its appearance and to help ensure years of dependable service. The following are suggested storage procedures:

- Thoroughly clean all debris off the mower to prevent damage from rotting grass and standing water.
- Lubricate all mower grease points and fill gearbox oil levels as detailed in the maintenance section.
- Tighten all bolts and pins to the recommended torque.
- Check the mower for worn and damaged parts. Perform repairs and make replacements immediately so that the mower will be ready for use at the start of the next season.
- Store the mower in a clean, dry place with the mower housing resting securely on blocks or at ground level.
- Keep the driveline yoke from sitting in water, dirt and other contaminants.
- Use spray touch-up enamel where necessary to prevent rust and maintain the appearance of the mower.



It is critical that driveline clutches slip when an obstacle or heavy load is encountered to avoid mower and/or tractor damage. If the mower sits outside for an extended period of time or is exposed to rain and/or humid air, the clutch lining plates must be inspected to ensure they are not frozen together from rust or corrosion. If the mower has been exposed to such conditions, at the start of each mowing season, and any time it is suspected that the slip clutch plates may be frozen together, readjust the slip clutch as detailed in Seasonal Clutch Maintenance of the maintenance section in this manual. OPS-F-0014



Never allow children to play on or around Tractor or Implement. Children can slip or fall off the Equipment and be injured or killed. Inadvertent contact with controls can cause the Implement to shift or fall crushing themselves or others. (SG-25)

OPERATION

14. TRANSPORTING THE TRACTOR AND IMPLEMENT

Inherent hazards of operating the tractor and implement and the possibility of accidents are not left behind when you finish working in an area. Therefore, the operator must employ good judgement and safe operation practices when transporting the tractor and implement between locations. By using good judgement and following safe transport procedures, the possibility of accidents while moving between locations can be substantially minimized. *OPS-U- 0017*

OPERATION



Never allow children or other persons to ride on the Tractor or Implement. Falling off can result in serious injury or death. (SG-10)



Before transporting the tractor and mower, idle the tractor engine, disengage the PTO and wait for all mower moving parts to come to a complete stop. Raise the mower sections and ensure transport locks engage.



OPERATION

Before transporting the tractor on a public roadway or boarding a trailer for transport, the tractor brake pedals should be locked together. Locking the pedals ensures that both wheels brake simultaneously while stopping, especially when making an emergency stop.

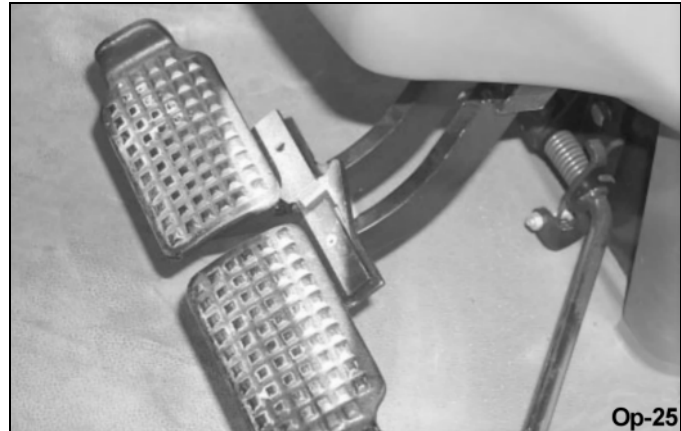

Use extreme caution and avoid hard applications of the tractor brakes when towing heavy loads at road speeds. Never tow the implement at speeds greater than 20 MPH (32 kph). OPS-U- 0018

If the tractor's hydraulic pump is not independent of the tractor PTO, or if the tractor PTO has to be run to have hydraulic power, disconnect the mower driveline from the tractor PTO output shaft. Secure the driveline to the mower deck to prevent driveline damage or loss during transport.

14.1 Transporting on Public Roadways

Extreme caution should be used when transporting the tractor and implement on public roadways. The tractor must be equipped with all required safety warning features including a SMV emblem and flashing warning lights to alert drivers of the tractor's presence. Remember that roadways are primarily designed for automotive drivers and most drivers will not be looking out for you, therefore, you must look out for them. Check your side view mirrors frequently and remember that vehicles will approach quickly because of the tractor's slower speed. Be extremely cautious when the piece of equipment that you are towing is wider than the tractor tire width and/or extends beyond your lane of the road.

Make sure that a proper size safety tow chain is secured between the tractor and implement before entering a public road. OPS-U- 0019

NOTE: Ensure that the mower sections are fully raised and that the transport locks are engaged for each section.



Only tow the Implement behind a properly sized and equipped Tractor which exceeds the weight of the Implement by at least 20%. DO NOT tow the Implement behind a truck or other type of vehicle. Never tow the Implement and another Implement connected in tandem. Never tow the Implement at speeds over 20 MPH. (STI-06)



Never allow children or other persons to ride on the Tractor or Implement. Falling off can result in serious injury or death. (SG-10)



OPERATION

WARNING

Make certain that the "Slow Moving Vehicle" (SMV) sign is installed in such a way as to be clearly visible and legible. When transporting the Equipment use the Tractor flashing warning lights and follow all local traffic regulations. (SG-6)

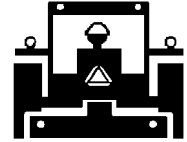

OPERATION

The SMV (Slow-Moving Vehicle) emblem is universal symbol used to alert drivers of the presence of equipment traveling on roadways at a slow speed. SMV signs are a triangular bright orange with reflective red trim for both easy day and night visibility. Make sure the SMV sign is clean and visible from the rear of the unit before transporting the tractor and implement on a public roadway. Replace the SMV emblem if faded, damaged, or no longer reflective. OPS-U- 0020



Make sure that all tractor flashing warning lights, headlights, and brake/tail lights are functioning properly before proceeding onto public roads. While newer model tractors have plenty of lighting to provide warning signals and operating lighting, most older models are only equipped with operating lights. Consult an authorized tractor dealer for lighting kits and modifications available to upgrade the lighting on older tractor models. OPS-U- 0021



When operating on public roads, have consideration for other road users. Pull to the side of the road occasionally to allow all following traffic to pass. Do not exceed the legal speed limit set in your country for agricultural tractors. Always stay alert when transporting the tractor and implement on public roads. Use caution and reduce speed if other vehicles or pedestrians are in the area. OPS-U- 0022



OPERATION

Reduce speed before turning or applying the brakes. Ensure that both brake pedals are locked together when operating on public roads. OPS-U-0023



OPERATION

15. Hauling the Tractor and Implement

Before transporting a loaded tractor and implement, measure the height and width dimensions and gross weight of the complete loaded unit. Ensure that the load will be in compliance with the legal limits set for the areas that will be traveled through.



Use adequately sized and rated trailers and equipment to transport the tractor and implement. Consult an authorized dealer to determine the proper equipment required. Using adequately sized chains, heavy duty straps, cables and/or binders, securely tie down both the front and rear of the tractor utilizing the proper tie down locations as specified by the tractor manufacturer.



OPERATION

Once the tractor has been loaded onto an adequate rated trailer, raise the side flail/flails into transport position and make sure the control levers are in the center lock position. Ensure the wing start/stop buttons are pushed in the stop position and shut down tractor. Remove key and exit the tractor.

Dual Wing

To exit and enter the tractor with a dual wing Terrain Master you will need to utilize the rear window. Unlatch the window and proceed to exit always using three point contact as shown on **Figure Ops-1463**.

When completely out of the tractor close window and strap window closed as shown in **Figure Ops-1464**.



WARNING Use both hands for support when getting on and off the Tractor. Always use three point contact when exiting or boarding Tractor.

Dual Wing w/Remote Valve Option

With units that have a Remote Valve, raise the right hand wing into transport position from the tractor seat. Once the right wing is in transport position, make sure control levers are in the center lock position and wing start/stop buttons are pushed in the stop position. Shut down tractor, remove key and exit the tractor. To raise the left hand wing into transport position you will need to use the Remote Valve installed in front of your tractor. Once left hand wing has been raised and locked into transport position, proceed to strapping the wings together.

OPERATION

Before tying down tractor with chains secure the flail wings together with a shipping strap. Refer to **Figure Ops-1465**



Arrange the chains so that when tightened the chains are pulling downward and against themselves. Carefully tighten the securing chains or other fasteners using boomers or binders to apply maximum tension. Use extreme care when attaching and removing the securing devices as the extreme tension involved when released has the potential to inflict serious injury.

While hauling the tractor and implement make occasional stops to check that the tractor and implement have not moved or shifted and that the securing chains have maintained tension. If during transport a hard braking, sharp turning, or swerving action was performed, stop at the next safe location to inspect the security of the load.



OPERATION

OPERATION

16. TROUBLE SHOOTING GUIDE

Problem	Possible Cause	Remedy
Excessive Vibrations	Check gearbox bolts. Check for missing knives on cutter shaft. Check to see if knives are free swinging. Blade broken or bent. Cuttershaft bent. Drivelines not phased correctly. Implement & Tractor yokes must be in line.	Tighten if loose Replace missing knives Free knives so they swing. Replace blades. Replace cuttershaft. Replace driveline.
Gearbox Overheating	Low on lubricant. Improper type lubricant. Excessive trash build-up around gearbox. Bearing or gears set up improperly.	Fill to level plug. Replace with proper lubricant. Remove trash. Consult your Dealer.
Gearbox Noisy	Rough Gears. Worn Bearing.	Run in or change gears. Replace bearing.
Noise	Damaged Belt Shield (Rubbing on pulleys or belt). Worn Bearing or Gear.	Straighten or replace Shields. Replace Bearing or Gear.
Gearbox Leaking	Damaged oil seal Bent shaft. Shaft rough in oil seal area. Oil seal installed wrong. Oil seal not sealing in the housing. Oil level too high. Sand hole in casting. Gasket damaged. Bolts loose.	Replace seal. Replace oil seal and shaft. Replace or repair shaft. Replace seal. Replace seal or use a sealant on OD of Seal. Drain oil to proper level. Replace castings or gearbox. Replace gasket. Tighten bolts.
Clutch Slips Excessively	Clutch linings badly worn or plates warped. Too much power for clutch. Oil on facings. Friction facings glazed.	Repair clutch per maintenance section of manuals. Reduce ground speed and material intake. Replace facings. Clean with emery cloth.

OPERATION

Knives Wear Too Fast	Cutting in sandy conditions. Cutting in rocky conditions. Soft "will fit" knives.	Increase cutting height. Increase cutting height. Use genuine Alamo Industrial knives.
Hydraulic Cylinder Will Not Operate	Not enough pressure. Valve not connected properly Quick coupler not completely connected.	Check Pressure Re-plumb valve. Complete connection.
Oil Squirting from Breather Vent Hole	Oil leaking by piston ring. Small leakage amount is normal. Piston "O" Ring worn. Cylinder wall scored or pitted. Wrong piston ring on piston.	Do not carry cutter on cylinder. Replace piston "O" Ring. Replace cylinder. Use correct piston ring.
Discharging Bunches or	Belt installed improperly. Blades dull. Grass too wet. Grass too long. Travel speed too fast. PTO RPM too low.	Check belt for correct set-up. Check blades for sharpness. Wait for grass to dry. Mow at 3-1/2" and recut lower. Use a lower tractor gear. Mow at engine RPM to match 540 PTO RPM.
Blades Scalping High Places	Mowing too low. Rough, uneven ground. Turning Tractor too fast.	Raise height of cut. Use a slower speed. Lower rollers. Slow down when turning.
Uneven Cut	Travel speed too fast. Mower deck not level. Blades dull or unbalanced. Deck underside plugged. Grass too high.	Use a slower speed. Level the mowing deck. Sharpen or balance blades. Clean underside of deck. Mow at 3-1/2" and recut lower.
Grass Clippings Windrow or clump	Grass too wet. Grass too high. Housing plugged.	Wait for grass to dry. Mow at 3-1/2" and recut lower. Clean underside of deck.
Grass Not being Cut Evenly	Belt worn or slipping. Spring broke & belt off idler. Housing plugged. Debris around pulleys. Grass too high.	Replace or adjust belt. Replace spring or adjust belt. Clean underside of housing. Remove deck belt shield and clean out debris. Mow at 3-1/2" and recut lower.



MAINTENANCE SECTION

Maintenance Section 5-1

MAINTENANCE

MAINTENANCE

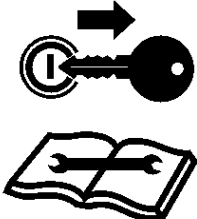
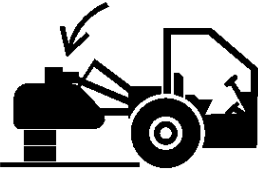
HAZARDS WITH MAINTENANCE OF IMPLEMENT

				
Periodically inspect all moving parts, lubricate drivelines, and tighten all fasteners	Stop engine remove key before conducting maintenance	Block up implement before servicing Use large blocks on soft or wet soil	Engage cylinder transport locks	Inspect Blades for damage or cracks

⚠ WARNING AVOID SERIOUS INJURY OR DEATH FROM COMPONENT FAILURE BY KEEPING IMPLEMENT IN GOOD OPERATING CONDITION IN PERFORMING PROPER SERVICE, REPAIRS AND MAINTENANCE.

BEFORE PERFORMING SERVICE, REPAIRS AND MAINTENANCE ON THE IMPLEMENT:

- **STOP ENGINE AND PTO**, engage parking brake, lower implement, allow all moving parts to stop and remove key before dismantling from tractor.
- **PLACE** implement on ground or securely block up raised equipment. Use large blocks on soft or wet soil.
- **PUSH** and **PULL** Remote Hydraulic Cylinder lever to relieve hydraulic pressure.
- **DISCONNECT IMPLEMENT** driveline from tractor **PTO SHAFT**.

WEAR SAFETY GLASSES, PROTECTIVE GLOVES and follow **SAFETY PROCEDURES** when performing service, repairs and maintenance on the implement:

- Always **WEAR** protective **GLOVES** when handling blades, knives, cutting edges or worn component with sharp edges.
- Always **WEAR GLOVES** and **SAFETY GLASSES** when servicing hot components
- **AVOID CONTACT** with hot hydraulic oil tanks, pumps, motors, valves and hose connection surfaces.
- **SECURELY** support or **BLOCK UP** raised implement, framework and lifted components before working underneath equipment.
- **STOP** any implement movements and **SHUT-OFF TRACTOR** engine before doing any work procedures.
- **USE** ladder or raised stands to reach high equipment areas inaccessible from ground.
- **ENSURE** good footing by standing on solid flat surfaces when getting on implement to perform work.
- **FOLLOW** manufacturer's instructions in handling oils, solvents, cleansers, and other chemical agents.
- **DO NOT** change any factory-set hydraulic calibrations to avoid component or equipment failures.
- **DO NOT** modify or alter implement, functions or components.
- **DO NOT WELD** or repair rotating mower components. These may cause vibrations and component failures being thrown from mower.

PERFORM SERVICE, REPAIRS, LUBRICATION AND MAINTENANCE OUTLINED IN IMPLEMENT MAINTENANCE SECTION:

- **INSPECT** for loose fasteners, worn or broken parts, leaky or loose fittings, missing or broken cotter keys and washers on pins, and all moving parts for wear.
- **REPLACE** any worn or broken parts with authorized service parts.
- **LUBRICATE** unit as specified by lubrication schedule
- **NEVER** lubricate, adjust or remove material while it is running or in motion.
- **TORQUE** all bolts and nuts as specified.

BLADE INSPECTION:

- **REPLACE** bent, damage, cracked or broken blades immediately with new blades.
- **AVOID** blade failures and thrown broken blades. **DO NOT** straighten, weld, or weld hard-facing blades.

SAFETY SHIELDS, GUARDS AND SAFETY DEVICES INSPECTION:

- **KEEP** all Deflectors, Steel Guards, Gearbox Shields, and PTO integral shields, Bands, Side Skirts and Skid Shoes in place and in good condition.
- **REPLACE** any missing, broken or worn safety shields, guards and safety devices.
- **DISCONNECT** Pump solenoid valve or PTO driveline connection before servicing mower head.
- **FOLLOW INSTRUCTIONS** in maintenance section when replacing hydraulic cylinders to prevent component falling.

⚠ WARNING Operating, servicing and maintaining this equipment can expose you to chemicals including gasoline, diesel fuel, lubricants, petroleum products, engine exhaust, carbon monoxide, and phthalates, which are known to the State of California to cause cancer and birth defects or other reproductive harm. To minimize exposure, avoid breathing exhaust, do not idle the engine except as necessary, service your vehicle in a well-ventilated area and wear gloves or wash your hands frequently when servicing your vehicle. Battery posts, terminals and related accessories contain lead and lead compounds, chemicals known to the state of California to cause cancer, birth defects or other reproductive harm. For more information go to www.P65Warnings.ca.gov. This website, operated by California's Office of Environmental Health Hazard Assessment, provides information about these chemicals and how individuals may be exposed to them.

PN HMFM-02

MAINTENANCE

PARTS INFORMATION

PARTS INFORMATION

Alamo Industrial mowers use balanced and matched system components for blade carriers, blades, cuttershafts, knives, knife hangers, rollers, drivetrain components, and bearings. These parts are made and tested to Alamo Industrial specifications. Non-genuine "will fit" parts do not consistently meet these specifications. The use of "will fit" parts may reduce mower performance, void mower warranties, and present a safety hazard. Use genuine Alamo Industrial mower parts for economy and safety. (SPAM-1)

SEE YOUR ALAMO DEALER

DAILY CHECKS

Before operating your Interstater, take the time to inspect and repair any damage to the machine or tractor. Only a minimum of time and effort is required to regularly maintain this machine to provide long life and trouble free operation.

1. Lubricate the INTERSTATER at the specified intervals as outlined in the lubrication diagram. Figure Mnt-FL-0001. All mower grease fittings are equipped with lubricaps which snap over the grease fittings to prevent dirt from entering the fittings. Remove the cap and wipe the fitting before greasing. Wipe the outlet of the grease gun then grease the bearing. When finished, place the cap over the fitting and wipe any excess grease from around the cap. In extremely dusty conditions, it is desirable to lubricate more often than every 8 hours. Grease PTO shaft as outlined on the diagram located on PTO shaft shield. The idler pulleys are equipped with a sealed ball bearing and require no further lubrication. Caster wheel bearings should be repacked at the end of each mowing season and checked before the start of the next season. The gearbox is shipped with the proper amount of SAE No. 90 extreme pressure lubricant. Maintain the level of this oil at the lower 1/8" pipe plug on the gearbox cover. LUBRICATE MOWER BEFORE INITIAL USE.

NOTE: Lubricate flail roller bearing until lubricant can be seen coming out between roller and bearing housing.

2. Before each day's use, follow this procedure:

- a. Visually check the unit, and make certain all items are properly tightened.
- b. Check the pump drive belt tension. If necessary, tighten the belt as instructed in this section.

NOTE: Cutter unit belt tension is maintained by a spring-loaded idler pulley.

c. Check the reservoir fluid level with the cutter units in the transport position. The oil level should be even with the sight glass located on the reservoir. Before removing filler cap, wipe the top of the reservoir to prevent dirt from entering the tank. Use Chevron 1000 THF or an equivalent.

NOTE: Your ambient temperature and operating conditions may require a different viscosity oil. Please consult the oil manufacturer for proper specifications.

NOTE: If the reservoir needs oil, a leak exists somewhere in the system. Repair the leak before using the unit.

d. Check the cuttershaft to make certain it is fully knifed. Replace any missing knives or cotter pins, then run the unit at full speed to check for vibrations. Do not operate the unit in an out-of-balance condition.



Never work under the Implement, the framework, or any lifted component unless the Implement is securely supported or blocked up to prevent sudden or inadvertent falling which could cause serious injury or even death. (SG-14)



MAINTENANCE

MAINTENANCE

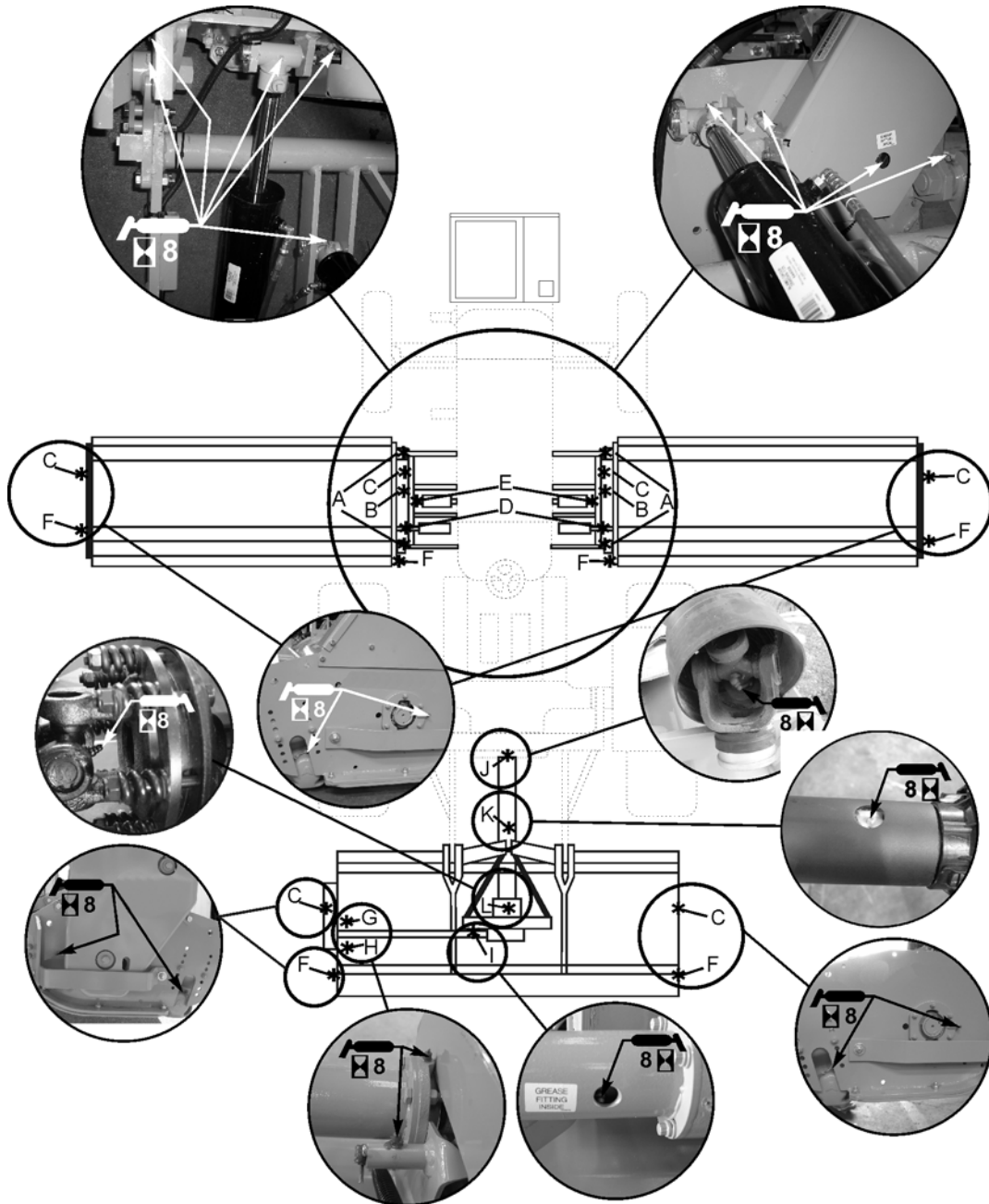

LUBRICATE ALL POINTS EVERY 8 HOURS OF OPERATION

 Use NLG1-with Lithium Grease

- | | | | |
|---|---------------------------|---|----------------------|
| A | LIFT FRAME PIVOT PIN | G | REAR MOWER IDLER ARM |
| B | WING MOWER BELT IDLER ARM | H | BANJO BEARING |
| C | CUTTER SHAFT BEARINGS | I | BANJO COUPLING |
| D | TILT CYLINDER ROD END | J | DRIVELINE YOKE |
| E | LIFT CYLINDER ROD END | K | DRIVELINE SHAFT |
| F | ROLLER BEARING | L | SLIP CLUTCH |

Mnt-FL-0001

MAINTENANCE

ADJUSTING TENSION OF DRIVEBELTS

1. Remove Pump Cover.
2. Loosen Pump Mount Plate bolt item 1 and 2. **Mnt-FL-0010**
3. Loosen Belt Tension Bracket bolt item 3. Mnt-FL-0010
4. Move pump unit outwards to increase tension on the belt. Belts should have no more than 1/4 inch play at midpoint between drive pulley and pump pulley. Tighten mounting bolts.
5. Replace Pump Cover.

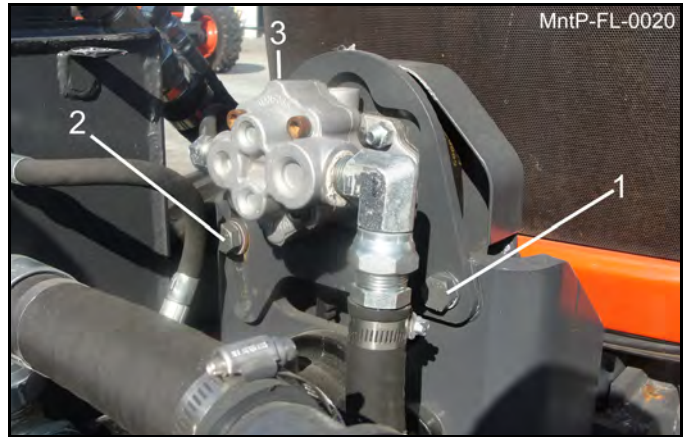

Hydraulic Fluid

Maintaining the proper hydraulic oil level and oil cleanliness is very important for continued trouble-free operation of the mower. The fluid level should be checked daily before the mower is put into service. A visual inspection of the hydraulic connections, hose guards and shielding should occur daily as well. The hydraulic fluid can lose its ability to lubricate in a number of different ways, most commonly contamination and overheating. Both scenarios can lead to catastrophic failure of the hydraulic components and costly repairs. Alamo Industrial offers fluids, filters, and oil analysis capabilities to help you maintain your hydraulic powered machine. Please be sure to follow the oil & filter change procedure that is outlined for your mower.

There are two types of hydraulic oil used by the factory, reference the chart below, Mobil DTE 16m and Chevron 1000 THF. Also, note the ISO cleanliness requirement for your mower

Product	Oil Type	Oil Specification	ISO Cleanliness	Filter Change Recommendation	Oil Change Recommendation
A-BOOM	UTF	Chevron 1000 THF	18/16/14	First 100/every 500 or 12 months	First 500/every 1000 or 12 months
AXTREME	UTF	Chevron 1000 THF	18/16/14	First 100/every 500 or 12 months	First 500/every 1000 or 12 months
BRAHMA	ISO AW68	Mobil DTE 16m	16/14/11	First 100/every 500 or 12 months	First 500/every 1000 or 12 months
EXTEN-A-KUT	UTF	Chevron 1000 THF	18/16/14	First 100/every 500 or 12 months	First 500/every 1000 or 12 months
FALCON	ISO AW68	Mobil DTE 16m	18/16/14	First 100/every 500 or 12 months	First 500/every 1000 or 12 months
*INTER-STATER	UTF	Chevron 1000 THF	18/16/14	First 100/every 500 or 12 months	First 500/every 1000 or 12 months
MACHETE I, II	ISO AW68	Mobil DTE 16m	16/14/11	First 100/every 500 or 12 months	First 500/every 1000 or 12 months
MAVERICK	ISO AW68	Mobil DTE 16m	16/14/11	First 100/every 500 or 12 months	First 500/every 1000 or 12 months

MAINTENANCE

MAINTENANCE

Product	Oil Type	Oil Specification	ISO Cleanliness	Filter Change Recommendation	Oil Change Recommendation
SAMURAI	UTF	Chevron 1000 THF	18/16/14	First 100/every 500 or 12 months	First 500/every 1000 or 12 months
SWITCH-BLADE	UTF	Chevron 1000 THF	18/16/14	First 100/every 500 or 12 months	First 500/every 1000 or 12 months
VERSA SIDE	UTF	Chevron 1000 THF	18/16/14	First 100/every 500 or 12 months	First 500/every 1000 or 12 months
VERSA BOOM	UTF	Chevron 1000 THF	18/16/14	First 100/every 500 or 12 months	First 500/every 1000 or 12 months

***Note:** Versa Pro & Rear mount Interstater also.

The above are prescribed intervals, but frequency may change based on use. It is important to monitor the filter clogging indicator. There are many comparable oils that are equivalent to what is used by the factory. An ISO class oil with a viscosity that matches your operating conditions is recommended. For further information please consult the oil manufacturer for proper specifications.

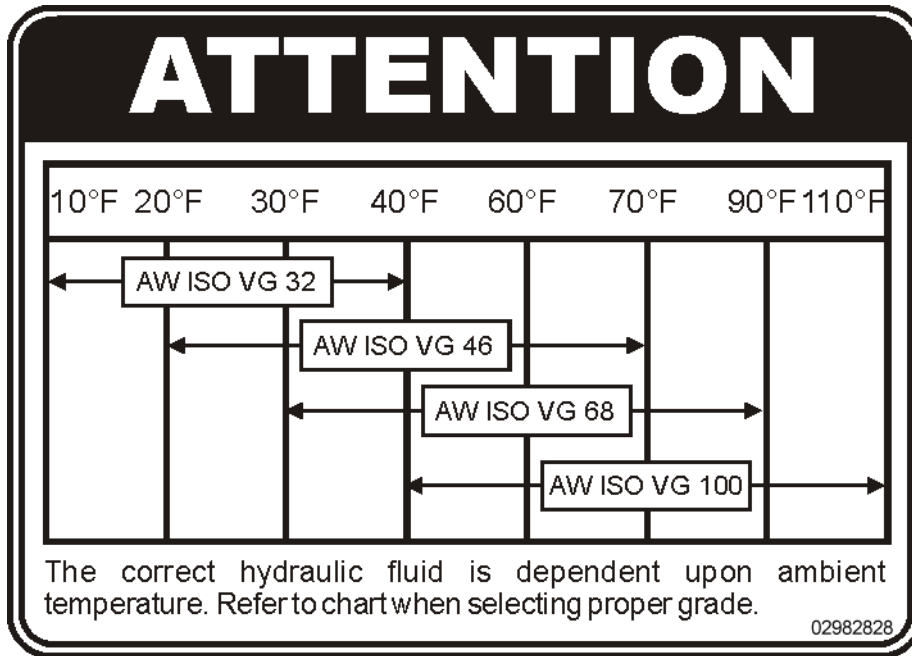

MAINTENANCE

MAINTENANCE

Proper Oil Level

.Maintain the oil level within the sight gauge located on the reservoir. When oil is cold, the level should be three-quarters up the sight gauge. Never fill the tank above that sight gauge level. A space is maintained above the sight gauge to allow for the expansion of the oil. Oil is added through the filler tube, if your tank does not have a filler tube then fill through the return filter located on the tank. Thoroughly clean the cap area around the filter to prevent oil from contamination. Remove the cap and add the proper viscosity grade of FILTERED oil to achieve the proper level. Never assume any oil is clean, including new.

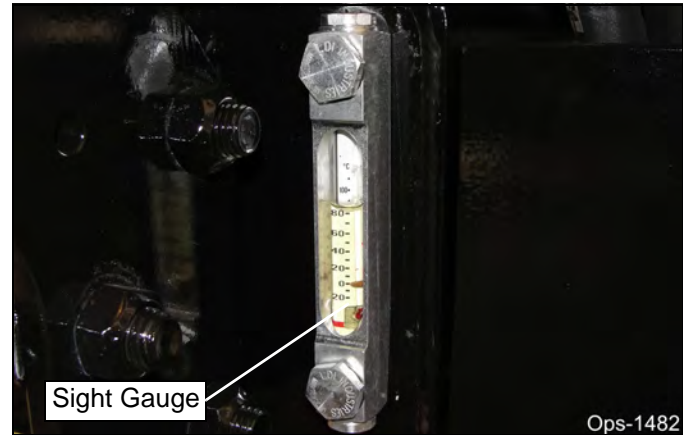

Oil Level Low

Low oil level in the reservoir is caused by leakage or improper filling. If leaking, locate the area of the leak and repair the leak at once. Loss of fluid can cause severe & catastrophic damage to the hydraulic components.

NOTE: After initial start up, the mower may require more oil to bring the oil level back to the proper level. This is normal. Air trapped in the hydraulic components was displaced by the oil, causing the oil level to go down in the tank. Oil must be added to reach the proper level or cavitation could result.

CHANGING HYDRAULIC SYSTEM FILTER

A large capacity filter is located on top of the hydraulic oil reservoir. **Mnt-FL-0009** The filter will trap particles which are .001 inch or larger. The filter needs to be changed after the first 10 hours of operation and every 200 hours or 12 months thereafter.



1. Clean the filter cover to prevent dirt from entering tank.
2. Loosen the four bolts on the filter cover. **Mnt-FL-0004** Remove one bolt from the filter to aid in removing the filter cover. **Mnt-FL-0005**
3. Push the filter cover down and slowly twist the filter cover off. **Mnt-FL-0006**
4. Remove filter spring. **Mnt-FL-0007**.

MAINTENANCE

MAINTENANCE

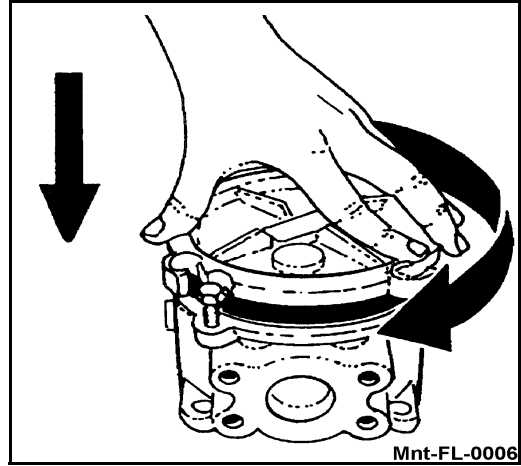
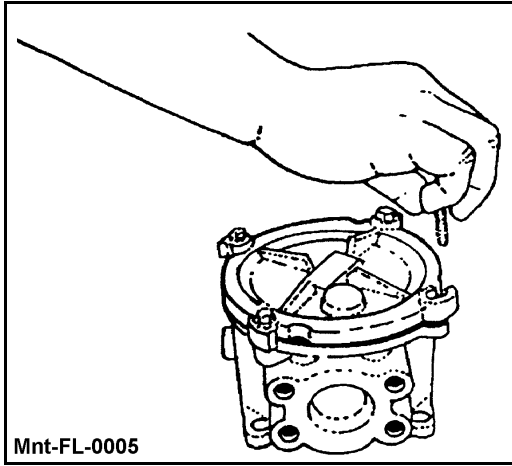

5. Remove filter. Inspect material trapped by the filter. It can indicate parts wear in the system. **Mnt-FL-0008**
6. Install the new filter.
7. Reinstall filter spring and filter cover. Replace the one bolt which had previously been removed. Tighten all bolts in an even manner. Mnt-FL-0009

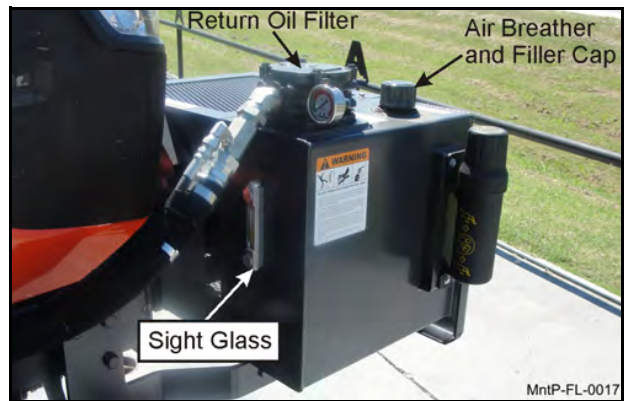
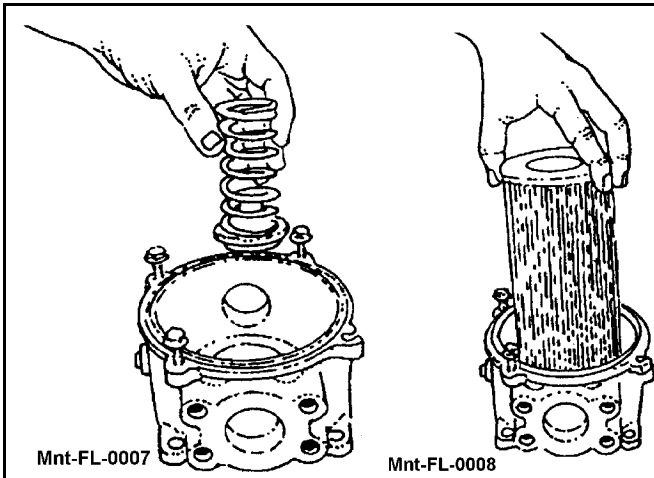

MAINTENANCE

CUTTER UNIT

A. GENERAL

The INTERSTATER electrical circuit controls the flow of oil to the hydraulic motor on the cutter unit. The motor control valve relies on a solenoid to control the spool within the valve and direct the flow of oil.

When the mower ON/OFF switch is in the "ON" position, current flows to the solenoid which positions the spool to direct the oil flow from the pump to the motor. The oil then turns the motor which drives the cuttershaft.

When the mower ON/OFF switch is in the "OFF" position, the solenoid is not energized and oil pressure in the power circuit pushes the spool back allowing the oil to return to the reservoir from the valve. Without the flow of oil, the motor will no longer drive the cuttershaft.

B. OFF-ON SWITCH

The electrical circuit is connected to the tractor ignition switch. (See Electrical Schematic). The yellow wire connects to the switch accessory terminal and the red wire connects to the start terminal. A 6 amp in-line fuse on the yellow wire protects the off-on switches from an overload. THE OFF/ON SWITCH HAS A SAFETY LOCK-OUT FEATURE THAT WILL NOT ALLOW THE TRACTOR STARTER TO ENGAGE IF SWITCH IS IN THE ON POSITION.

C. SAFETY CUT-OFF SWITCH

In the electrical circuit between the OFF-ON switch and the motor solenoid valve is a safety cut-off switch. This switch is a cam-operated electrical switch that cuts the wing mowers off when the wing is raised to approximately 60 degree angle. This also prevents mower from being operated with the wing up. This feature prevents injury due to inadvertently starting mower with wing raised and should be kept in proper operating condition.

D. SOLENOID OPERATED VALVE AT MOTOR

The electric solenoid valve is mounted in the hydraulic motor manifold block. The solenoid controls the spool within the valve. When the off-on switch is on and the wing is lowered the solenoid is energized by electrical current and the spool is closed to direct the flow of oil from the pump through the cuttershaft hydraulic motor. The wing activates the safety cut-off switch, the electrical current is removed from the solenoid causing the spool to open and allows oil to return to tank without being directed through the motor. Without oil flow through the motor, the cuttershaft will not operate.

GENERAL MAINTENANCE

Mowing is accomplished by a series of knives which rotate at high speed on a shaft. The shaft is driven by a hydraulic motor through a set of drive belts. Belt tension is maintained by a spring-loaded idler pulley.

The cutter unit is mounted to the lift frame by two mounting pins and held in place by a hydraulic cylinder. This cylinder is used to tilt the cutter unit to allow mowing on an angle and tilting to the vertical position for transporting. Another hydraulic cylinder is mounted to the lift frame and the lift cylinder support. This cylinder is used to raise the cutter unit via the lift frame.

The cutter unit rides on a large roller assembly. The position of this roller is adjustable and will determine the cutting height of the knives.

MAINTENANCE

REPLACING CUTTER UNIT DRIVEBELTS

NOTE: Belts must be replaced as a set. DO NOT replace just one belt.

1. Place unit on ground or support securely.
2. Remove belt guard.
3. Remove idler arm spring.
4. Remove motor mounting bracket front bolt and loosen rear bolt.
5. Pivot motor-mounting bracket assembly. Remove old belts and install new ones.
6. Reinstall front mounting bolt then secure motor mounting bracket to unit.
7. Reinstall idler arm spring and belt guard.

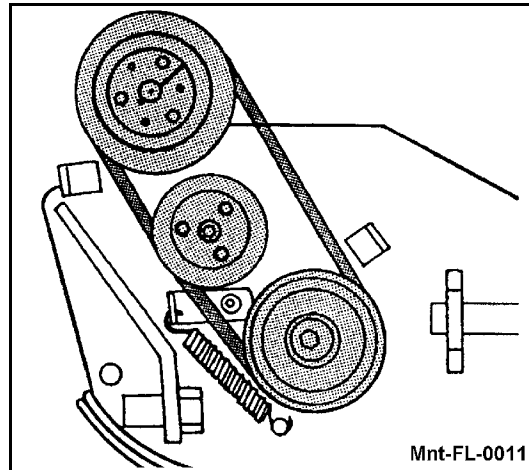

ADJUSTING CUTTING HEIGHT

1. Lower cutter unit to ground and place control valve levers in "FLOAT" position.
2. Place lifting device (scissors jack, hydraulic jack) under center of cutter housing.
3. Remove hex nuts, washers and carriage bolts from bracket at each end of roller. Make certain that roller bracket is free to move once the fasteners are removed. A stuck roller could drop suddenly and cause an injury.
4. Use lifting device to reposition cutter housing to desired cutting height. Align bracket holes with cutterhousing holes, then reinstall fasteners. Refer to cutting height decal on mower or Safety Section.
5. Lower cutter unit to ground; then remove lifting device.

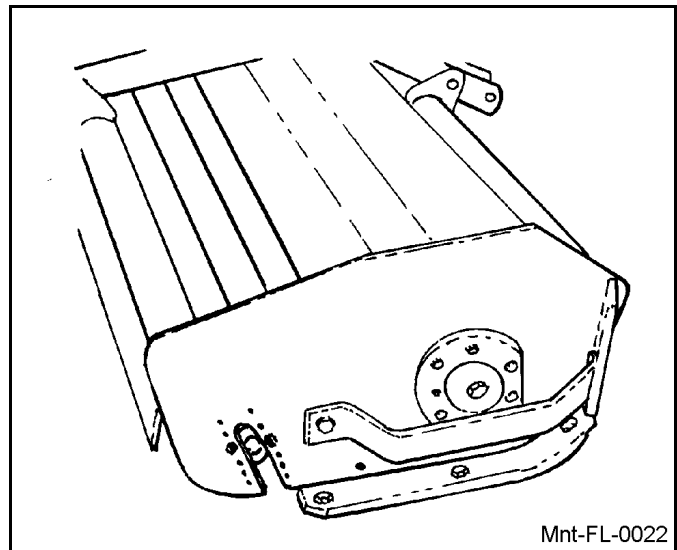

MAINTENANCE

ROLLER BEARING REPLACEMENT



Securely support mower while removing and installing roller assembly.

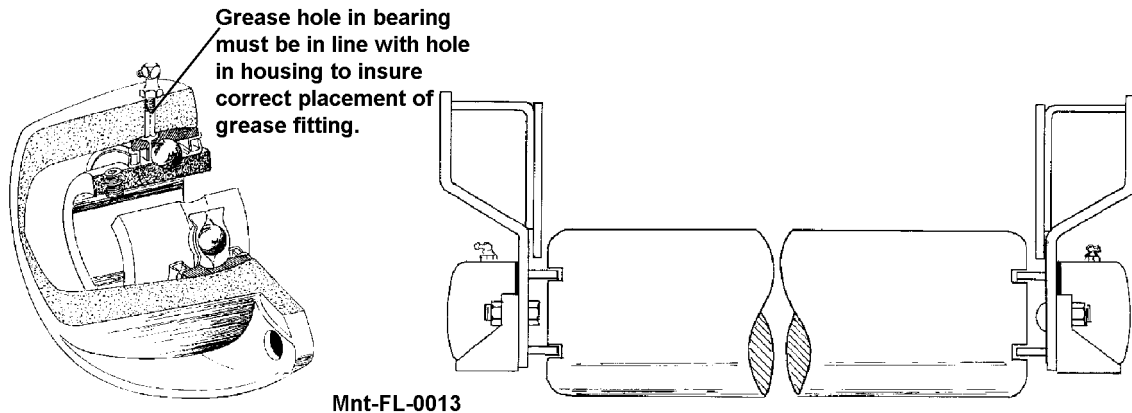

MAINTENANCE

1. Remove roller and both bearing and bracket assemblies from mower. Lift the mower only high enough to remove the roller assembly. If installing a roller with pre assembled bearing and bracket assemblies, remove the old roller, proceed to step 11.
2. Slide bearing and bracket assemblies off each end of roller. If replacing with new bearing and bracket assemblies, proceed to step 9.
3. Remove roller bearing and housing assembly attaching hardware. Remove assembly from bracket. Inspect seal between assembly and bracket for brittleness, cracks, wear and tear. Replace if necessary. If replacing with new roller bearing and housing assemblies, proceed to step 8.
4. Remove grease fitting from the top of bearing housing.
5. Remove bearing from housing. By Rotating Bearing 90deg. sideways and line up with notches in Bearing Housing: then pull out.
6. Install new bearing into housing. Bearing must be installed with grease hole in bearing aligned with grease fitting hole in housing.
7. Reinstall grease fitting to housing. Grease fitting must be tight and seated in grease hole in bearing to prevent bearing from rotating in housing.
8. Attach roller bearing and housing assembly to bracket with seal between housing and bracket.
9. Slide bearing and bracket assemblies on each end of roller.
10. Check bearing for proper installation in housing by gently rocking bearing and bracket assembly in end of roller. Play should be slight to none at all.
11. Install roller and bearing and bracket assemblies on mower.
12. Lubricate roller bearing until lubricant can be seen coming out between roller and bearing housing.

MAINTENANCE

CUTTERSHAFT BEARING REPLACEMENT

Outboard Bearing

1. Lift cutter unit to maximum horizontal height; then securely support ends of cutterhousing.
2. Remove enough knives to place a floor jack under center of cuttershaft.
3. Securely support cuttershaft.

NOTE: The cuttershaft must remain supported while changing bearings.

4. Remove outboard fender.
5. Remove fasteners securing bearing and housing assembly to cutterhousing, then remove bearing and housing assembly.

NOTE: There are two tapped holes in the housing which can be used to pull bearing and housing assembly out by using special tool No. 701627.

6. Using a jack to align parts, install bearing and housing assembly to cutter unit and make certain that bearing setscrew is located in keyway on cuttershaft. Grease bearing and install cap over fitting.

If only the outboard bearing and housing assembly is to be replaced, proceed as follows: Remove jack and check shaft rotation. Reinstall knives which were removed. Reinstall outboard fender. Remove supports, lower unit to ground and test unit.

If the inboard (drive) bearing is to be replaced, proceed to step 7.

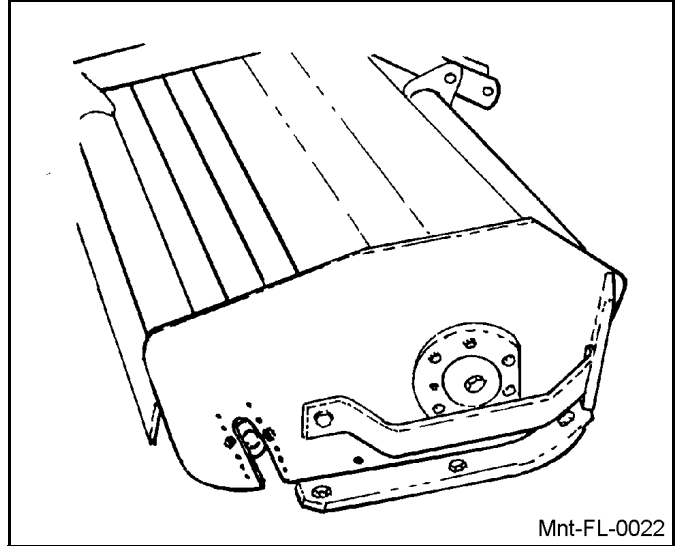

MAINTENANCE

MAINTENANCE

Inboard (Drive) Bearing

1. Remove spring from idler arm. **Fig. Mnt-FL-0013**
2. Remove motor mounting bracket fasteners, at the cutterhousing. Pivot motor-mounting bracket
3. Remove fasteners that secure pulley to cuttershaft. Remove pulley and key.
4. Remove fasteners securing inboard bearing and housing assembly to cutterhousing, then remove bearing and housing assembly. Refer to **Mnt-FL-0011**

NOTE: There are two tapped holes in the housing which can be used to pull bearing and housing assembly out by using special tool No. 701627.

5. Using a jack to align parts, install inboard bearing and housing assembly to cutter unit. Grease bearing and install cap over fitting.
6. Reinstall key and pulley. Secure with cuttershaft fasteners.
7. Remove jack and check shaft rotation. Reinstall knives which were removed.
8. Reinstall drive belts then secure motor mounting bracket to cutterhousing.
9. Reinstall idler arm spring.
10. Reinstall belt guard.
11. Remove supports, lower unit to ground and test unit.
12. Reinstall outboard fender, if not already installed.

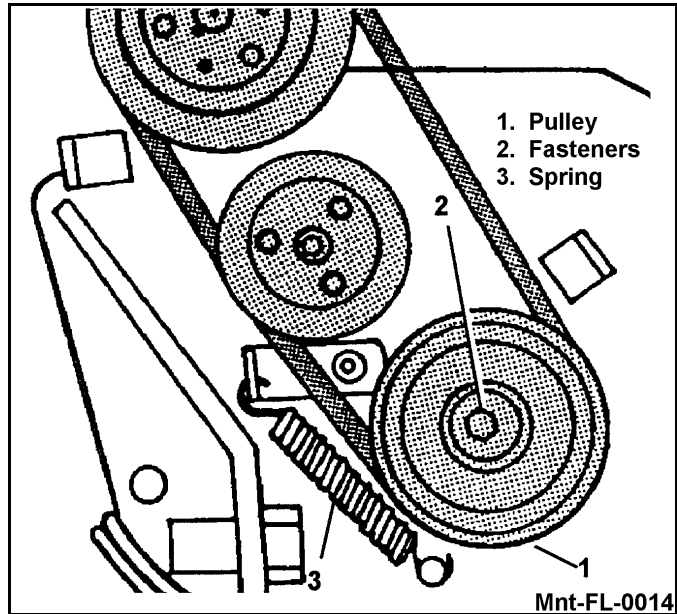

CUTTERSHAFT REPLACEMENT

NOTE: It is recommended that cuttershaft bearing and housing assemblies be replaced when replacing cuttershaft.

1. Place unit on the ground or securely support at a convenient height.
2. Remove cuttershaft bearing and housing assemblies as outlined in Paragraph "E", above. After removing both assemblies, the cuttershaft can be removed and a new one installed. It may be necessary to remove two sets of knives nearest the drive end of cuttershaft.
3. Install new bearing and housing assemblies as outlined in Paragraph "E".

MAINTENANCE

MAINTENANCE

CHANGING TO FORWARD OR REVERSE ROTATION

Wing Mowers

The hydraulic wing motors are dual rotation motors which means they will rotate in either direction depending on the inlet port used. An arrow on the flat surface of the motor housing at both ports indicate the direction of rotation. To change rotation, remove the four bolts that mount the manifold block to the motor. Remove the case drain hose at the motor, but leave it attached in present location at the manifold block. Leave all other plumbing as presently installed at the manifold block. Remove the two mounting bolts at the motor mounting plate and rotate the motor 180 deg. This changes the present inlet port into the outlet port of the motor. Re-install manifold block but do not change the position. Install case drain hose.

Rear Mower

To change direction of cuttershaft rotation for the rear mower, three left hand parts are required. A belt guard, an outboard bearing plate and a idler pulley arm. (Consult parts book for these part numbers). Remove the cuttershaft and turn 180 deg. Remove the gearbox cuttershaft drive pulley and outboard bearing plate, (using the proper bearing plate) mount the plate to opposite side of mower housing. Remove the four bolts that mounts the gearbox and rotate gearbox 180 deg. to new position. Install cuttershaft pulley, gearbox output pulley, idler arm pulley assembly and belt. **REPLACE EXISTING BELT GUARD WITH PROPER GUARD.**

REPLACING CUTTER UNIT KNIVES

The cutter knives are attached to the cutter shaft with hardened pin and cotter pins. These pins are supplied with the knife kit. To remove existing knives, remove and discard these pins and install new knives using new pins. **Figure ASM-FL-0047**

FOR FORWARD ROTATION: On the right wing and rear unit, all knife pins must be installed with their heads facing away from the cuttershaft pulley. On the left wing, the heads of the knife pins must face the cuttershaft pulley.

FOR REVERSE ROTATION: On the right wing and rear unit, all knife pins must be installed with their heads facing toward the cuttershaft pulley. On the left wing, and rear unit, the heads of the knife pins must face away from the cuttershaft pulley.

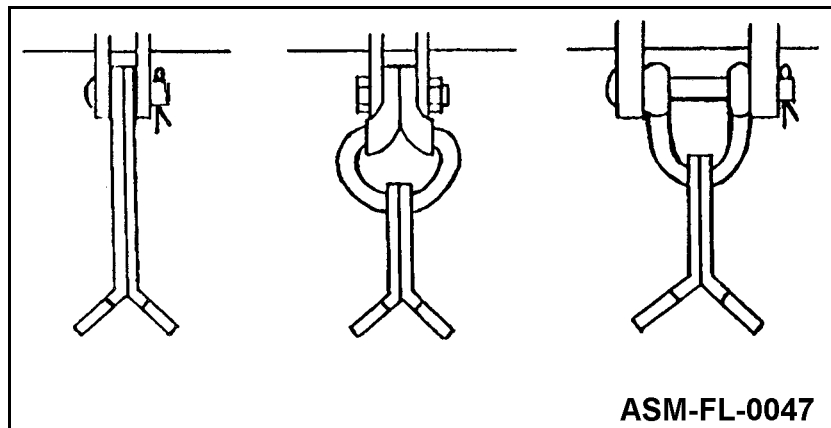

MAINTENANCE

MAINTENANCE

Flail Blades Inspection



Inspect the Blades daily for abnormal wear. REPLACE ALL BLADES on the carrier IMMEDIATELY if any blades have:

- Become bent or deformed from its original shape, or
- Wear inside the blade bolt hole, or
- Any cracks are visible, or
- Deep gouges in the blade's surface are present, or
- Gouges or chipped areas in the cutting edge are larger than 1/4"(8mm), or
- The material on the leading edge has been worn away by more than 1/4"(8mm)

DO NOT straighten, sharpen, weld or hard-face blades

Failure to replace worn or damaged blades may lead to catastrophic failure of the blades and ejection of the broken part with tremendous force which may cause serious bodily injury or death.

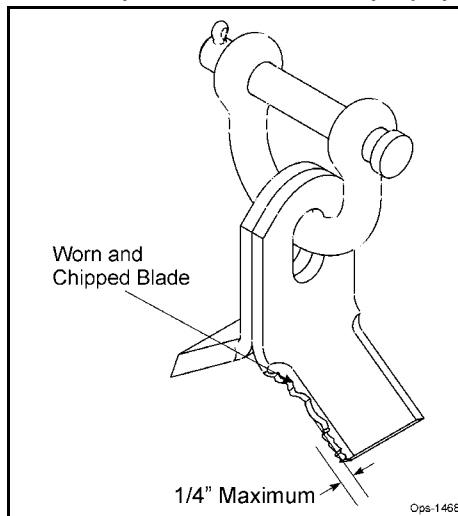

Always replace blades in sets

- Blades that are damaged may indicate severe service or abuse. If one blade is worn or damaged other blades on the same shaft will have been subjected to the same severe service or abuse.
- The Flail rotor turns at speeds exceeding 2000 RPM and is dynamically balanced at the factory. Differences in blade weight between used blades with loss of material from gouges or wear as compared to new blades can cause severe vibration and damage to the Flail rotor. Always replace blades as complete sets.

Important

Use only genuine Alamo Industrial replacement blades and fasteners. Other blades and fasteners may not meet the Alamo Industrial requirements and could fail during operation resulting in part being thrown out from under the mower.



Never attempt to sharpen blades. OPS-U-0044

MAINTENANCE

Blade Pins and D-Ring Inspection

Blade Pins and D-Rings daily for wear or damage as follows:



Inspect the Blade pins and D-Rings daily for abnormal wear. Make sure the cotter pins are in place and properly spread. REPLACE BLADE Pins and D-Rings IMMEDIATELY if they have:

- Visible cracks or
- If a Pin or D-Ring has visible worn areas, or
- If a Pin or D-Ring has gouges or chipped areas

Failure to replace abnormally worn pins or D-Rings may lead to catastrophic failure and ejection of the broken part which may cause serious bodily injury or death.

Always replace the pins and D-Rings whenever excessive wear is noticed.

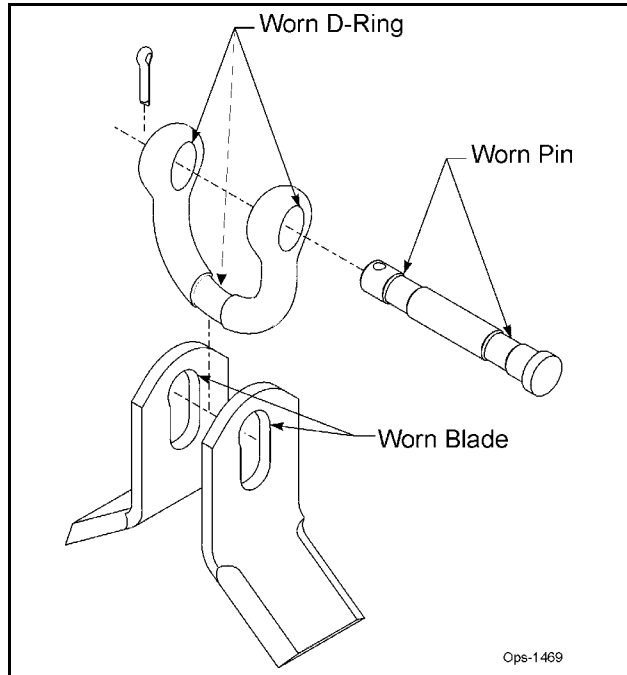

Important

If the cotter pins are broken by contact with other flail blades, remove the pin and reverse the direction the pin is inserted through the D-Ring so that the cotter pin is on the opposite side of the D-Ring. This will prevent the next set of blades from swinging back and hitting the cotter pin. OPS-U-0045

MAINTENANCE

General Information on Flail Mower Vibration

FLAIL MOWERS INFORMATION BULLETIN NO. 5

EXCESSIVE VIBRATION

Vibration is a MONSTER and if allowed to continue unchecked, can cause the complete break-up of a machine in a very short time.

A properly operated Flail Mower will produce very little vibration. If vibration does occur, the mower should be stopped and the trouble corrected, as warranty does not cover failures resulting from continued operation after something happens to cause the mower to vibrate excessively.

Vibration is caused by a rotating part which is out of balance. This could be the cutter shaft or, on those models having a universal slip joint assembly drive shaft, from the drive shaft.

If the two extreme ends of the drive shaft, (the yoke splines which fit on the tractor power take off shaft and on the mower gear box driven shaft), are not parallel, vibration will be evident.

This is because of the mechanics of a universal drive wherein the rotational speed thru a universal joint is not uniform. If the ends of a universal drive shaft are parallel, the uneven rotation effect is cancelled out and the machine being driven will be driven at a uniform rate of speed. However, if the ends are not parallel, the uneven rotation effect may be multiplied, resulting in a speeding up and slowing down of the entire mower system (gear box, extension shaft, pulleys, belt, and cutter shaft) each revolution. This effect can be readily noticed if the mower, while running, is raised to an extreme height on the tractor lift.

For smoothest operation, the tilt of the mower should be adjusted (on a 3-point hitch, by adjusting the length of the top link between the tractor and the mower) so that the ends of the drive shaft are parallel when the mower is down in operating position. Raising the mower, while running, to extreme heights on the lift should be avoided.

To check where the vibration is originating, first be sure the ends of the universal drive shaft are parallel. Then, if vibration is still present, remove the drive belt and run the mower. If vibration is still present, it most likely is coming from and caused by a bent drive shaft. If so, the shaft should be replaced or straightened. If the vibration is gone - the drive portion of the mower is running smoothly - then the vibration is probably coming from the cutter shaft (it could be a pulley out of balance or a faulty belt with a varying cross section, but this is not likely).

The cutter shaft will run out of balance if:

1. Wire, rope, string, rags, etc., around the cutter shaft, are holding the knives in a folded back position. Remove such foreign objects and be sure all knives are free to swing to the extended position.
2. Knives are missing or broken. Replace missing or broken knives.
3. Knife hanger lugs are broken off shaft. This condition usually results from continued operation in contact with large hard objects where the knife hanger lugs themselves are hitting the hard objects. Lugs should be replaced using arc welding equipment so as not to direct too much heat in one area of the shaft.
4. Cutter shaft ball bearings are worn enough to have radial "play" in them. Replace ball bearing and other worn parts to eliminate "play".
5. Shaft is bent. The shafts are straight within a couple of thousandths of an inch when they are made. It is possible that they will become bent in use, such as if the shaft is hooked on a stump while the tractor is moving forward at a good speed.
6. Shafts are operated at improper speed. Rotating shafts have what is known as a natural period of vibration. The same is true of the cutter shafts on the Flail Mowers.

The actual speed at which the harmonic will occur will vary with each mower and each installation. To avoid this harmonic vibration when operating the mower, it may be necessary to adjust the engine speed of the tractor up or down.

Some units have a harmonic vibration which occurs below the nominal operating speed. On these units, it will be noticed that there is always a little vibration at a particular RPM as the mower is being sped up to operating speed. This occurs as the shaft passes through its normal harmonic vibration point. As long as the mower is operated at the proper speed, then harmonic vibration will not be an issue.

MAINTENANCE

HYDRAULICS

General

The INTERSTATER hydraulic system consists of two circuits. The power circuit drives the cuttershaft. The control circuit lifts and tilts the cutter unit.

A tractor with a cutter unit installed on each side will have two independent power circuits with two sets of lift and tilt cylinders, and one control circuit with a four-section control valve (instead of a two section valve).

NOTE: It is important that pipe thread sealant be used on solid connections only; never on connections between swivel fittings or fittings with "O" rings and straight threads. Use pipe thread sealing compound. DO NOT substitute other types of sealant, such as teflon tape, paint, shellac, etc.

Initial Start-Up Procedures

Whenever the hydraulic system is drained in order to service a hydraulic component, the following start-up procedure should be completed.

1. Check all nuts and hex head capscrews to be sure they are tight and that all lock washers are fully compressed.
2. Check all hoses and hydraulic connections to be sure that they are tight.
3. Inspect all moving parts, and make certain that no wires or hoses will be caught or pinched when the tractor is in operation.
4. Secure all wires and hoses.
5. Thoroughly lubricate the INTERSTATER. Refer to SECTION 2, Illustration 4.
6. Change the hydraulic filter and fill the reservoir to the sight glass with new hydraulic oil. Refer to SECTION 1 for specifications.



Remove all objects from, and stand clear of the front of the cutter unit. DO NOT GET NEAR ROTATING KNIVES.

7. Turn mowers off, then start tractor and run engine at low idle. Operate the lift and tilt circuits, and the power circuit (turn cutter units on ONLY when mowers are fully lowered). Operate until the system is fully charged. Recheck the fluid level and add oil, if necessary. If undue noise continues after the system is fully charged, stop the unit and determine the cause.
8. After the hydraulic system is fully charged and functioning properly, switch the mowers on and increase the engine speed to run the PTO at 540 RPM. Maintain this speed for 5 minutes and look for any leaks or possible problems.

MAINTENANCE

Troubleshooting

The following shows various problems, the apparent cause, and the recommended procedure for their correction.

PROBLEM	POSSIBLE CAUSE	REMEDY
Mower will not rotate	In line Fuse blown. Safety switch not making contact. Broken Drivebelts. On/Off Switch bad. Insufficient voltage through Solenoid. Solenoid Spool will not shift completely.	Replace Fuse. Adjust or replace Safety Switch. Replace Belts Replace On/Off Switch Check Coil and Wires. Clean or replace Solenoid Cartridge.
Mower will not stop.	Solenoid Spool will not shift.	Clean or replace Solenoid Cartridge.
Intermittent mowing power.	Safety Switch maladjustment Electrical problem. Bad Solenoid.	Adjust Safety Switch. Trace Electrical Circuit for short. Replace Solenoid Coil.
Insufficient cutting power or low Cuttershaft speed.	Drivebelts slipping. Bound Shaft. Relief Valve setting too low. Solenoid Spool will not shift completely. Worn Pump or Motor.	Readjust Belt tension and check. Free the Shaft. Adjust Relief Valve. Replace Valve Cartridge. Replace or rebuild.
Hydraulic Oil overheating Mower free to rotate.	Low Fluid level. Relief Valve setting too high. Obstruction in Power Circuit-Extra or Will-Fit Parts.	Fill to proper level. Adjust Relief Valve. Remove obstruction & Extra Items which are not standard.
Pump making loud noise.	Low Oil level. Vacuum in reservoir. Clogged Oil Filter. Worn Pump.	Add Hydraulic Fluid. Clean or replace Vent Plug. Replace Filter. Replace or rebuild.
Mower will not raise or raises slowly.	Slow Gear Pump speed. Relief Valve Setting too low. Worn Gear Pump. Worn Cylinder. Worn Control Valve.	Check Belts, Idler Pulley, Spring. Adjust Relief Valve. Replace or rebuild. Replace or rebuild. Replace Valve Section.

MAINTENANCE

POWER CIRCUIT

The pump unit assembly is made up of the oil reservoir, and hydraulic pump. The pump is driven by the engine crankshaft through a drive shaft. Therefore, oil is being pumped whenever the engine is running. When the mower is off, oil is directed to the reservoir by the solenoid motor control valve and does not flow to the cutter motor. Cooling is provided by patented in frame cooling tubes in the wing mowers.

Replacing Hydraulic Pumps

The pump unit assembly is made up of the oil reservoir, and hydraulic pump. The pump is driven by the engine crankshaft through a drive shaft. Therefore, oil is being pumped whenever the engine is running. When the mower is off, oil is directed to the reservoir by the solenoid motor control valve and does not flow to the cutter motor. Cooling is provided by patented in frame cooling tubes in the wing mowers. **Figure Mnt-FL-0015**

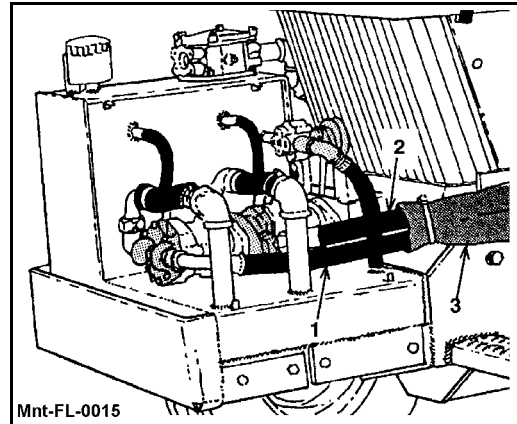

Replacing Outer Pump

9. Remove the Pump Cover by unscrewing the four thumb screws which hold it in place.
10. Disconnect the outer Pump Suction Hose, Pump Drain Hose, and the Pressure Hose.

NOTE: Clean spills at once. Cap all hoses immediately to prevent contamination of the hydraulic system.

1. Remove the two bolts which attach the outer pump to the inner pump flange.
2. Remove Pump. Lightly oil new "O" Ring and place on inner pump flange. Install the new Pump with the pump drain ports facing Hydraulic Tank.
3. Reinstall hydraulic hoses. Tighten hose fittings to their proper torque. Refer to Torque Chart.
4. Reinstall Pump Cover and tighten the four thumb screws securely.
5. Replacing Inner Pump:
6. To replace inner pump both pumps must be removed. Follow same procedure as for outer pump. BE SURE TO CAP ALL HOSES AND CLEAN OIL SPILLS AT ONCE.

NOTE: Clean spills at once. Cap all hoses immediately to prevent contamination of the hydraulic system.

7. Separate the inner pump from the outer pump and install new pump to inner pump following step 4 making sure both case drain ports are facing hydraulic reservoir.
8. Reinstall pumps to pump mounting bracket.
9. Reinstall all hoses. Tighten hose fittings to their proper torque refer to torque chart.
10. Reinstall all guards.

MAINTENANCE

Solenoid Control Valve

The solenoid control valve directs oil flow from the hydraulic pump. When the mower ON/OFF switch is in the "ON" position, the solenoid is energized and the spool within the valve is positioned to direct oil to the cuttershaft motor.

When the mower ON/OFF switch is in the "OFF" position, oil pressure within the valve pushes the spool back which allows the oil to circulate through the cutter unit before returning to the reservoir. When the flow of oil to the motor is cut off, the cuttershaft will stop rotating. **Figure Mnt-FL-0017**

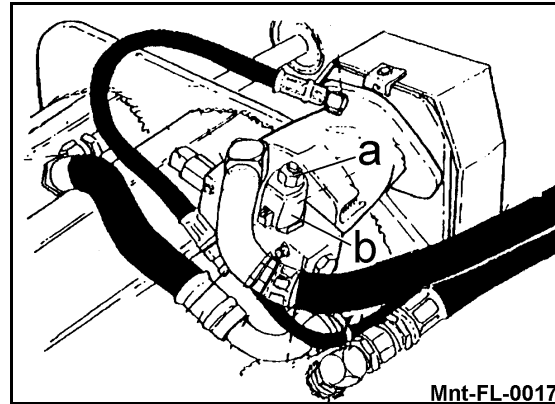

a. Control Valve

b. Solenoid

Checking Solenoid Valve

1. With engine running, turn the mower ON/OFF switch in the "ON" position. Check voltage level at the solenoid.
2. If it is less than 12 volts, check wiring and ground connections. Checking ground wire is as important as checking the hot wire. If voltage is sufficient, the solenoid valve is bad and will need to be replaced.

Hydraulic Pump

DISASSEMBLY

1. Disconnect all hydraulic lines. Remove pump assembly from tractor.
2. Plug all ports and thoroughly clean outside of pump.
3. Clamp the end of the drive shaft in a protected jaw vise with the body of the pump up and remove the six cap screws from the back plate.
4. Use a plastic mallet and tap the back plate assembly to loosen it, then pull back plate straight up until it is free. Remove gasket.
5. Remove pump from vise and remove rotating assembly from pump housing.
6. If the pistons did not come out with the piston block, remove them, the spider, and the spider pivot.
7. The piston block assembly need not be disassembled unless the internal pins of spring is damaged.



The following procedure should be used if the spring is to be removed from the piston block assembly. The spring is highly compressed and the snap ring should not be removed without first compressing the spring.

The following parts will be needed to disassemble the piston block:

- 2 ea. 3/8 I.D. x 1-1/8 O.D. flat washer
- 1 ea. 3/8 x 3-1/4 N.C. capscrew
- 1 ea. 3/8 N.C. nut

Place one of the flat washers over the 3/8 x 3-1/4 cap screw and place this through the center of the piston block. Place the other washer over the cap screw and let it rest on the three pins. Screw the nut on and compress the spring inside the piston block. Use a pair of snap ring pliers and remove the internal snap ring. Remove the bolt and the two washers. Remove the washers, spring, three pins, and the internal pin keeper.

8. Remove snap ring from housing. Press shaft from housing and remove shaft seal and washer.
9. Remove the two snap rings, thrust bearing, and two thrust washers from the drive shaft.

MAINTENANCE

10. To remove the cam plate from housing, remove the four screws from sides of the housing. Remove trunnion cover, seal cover, and o-ring cover. Remove o-ring, seal, two washers, inner race, and needle bearings. The cam plate can now be moved over to one side and removed. The cam plate pivot bearing are a loose slip fit into the housing. Do not be concerned if they are not tight.

Inspection of Hydraulic Pump

1. Inspect flat surface of the backplate. The finish on the piston block side should be smooth and free of grooves. **DO NOT LAP BACKPLATE WEAR SURFACE.** The backplate should be replaced if it shows any of the wear characteristics outlined above. Inspect the needle bearing in the backplate. If the needles are free of excessive play and remain in the bearing cage, there is no need to replace the bearing.
2. Inspect the piston block. The wear surface that contacts the backplate should be smooth and free of grooves. **DO NOT LAP PISTON BLOCK.**
3. The pistons should move freely in the piston block bores. If they are sticky in the bore, examine the bore for scoring or contamination.
4. Examine the O.D. of the pistons for finish condition. They should not show wear or deep scratches. The shoes should be a snug fit on the ball end of the pistons. The flat surfaces of the shoes should be flat and smooth. **DO NOT LAP THE PISTON SHOES.**
5. Examine the spider. It should be flat, no cracks and no signs of wear in the pivot area.
6. Examine the pivot. It should be smooth and show no signs of wear.
7. The cam plate should be inspected for the condition of the finish of the polished shoe surface. It should show no signs of scoring. Inspect the cam plate pivot bearings. If the needles are free of excessive play and remain in the bearing cage, there is no need to replace the bearing.
8. Inspect the drive shaft for fretting in the bearing and spline areas.
9. Inspect the thrust bearing and thrust washers for wear.
10. Inspect the needle bearing in the housing. If the needles are free of excessive play and remain in the bearing cage, there is no need to replace the bearing.

REASSEMBLY

1. Clean all parts in a suitable solvent. Lubricate all critical moving parts before reassembly. If necessary, install new needle bearing in housing with numbered end of bearing outward.
2. Insert cam plate into housing. Insert needle bearings and inner race. The chamfered I.D. of the race should be inward. Install washers, o-ring seal, o-ring cove, trunnion cover, seal cover, and retain with four screws and tighten to 36-48 in. lbs.
3. Install snap ring on shaft. Install thrust washer, thrust bearing, and second thrust washer. Secure with second snap ring.
4. Install shaft in housing and install washer and shaft seal and retain with snap ring.
5. Compress pin keeper and install in the spline of the piston block. Install the three pins with head end to the inside of the block, and install in the special grooves of the piston block spline.
6. Install washer, spring, and second washer in the piston block. Use the two 3/8 I.D. washers and the 3/8 x 3-1/4 cap screw to compress the spring and retain with snap ring. Remove the 3/8 x 3-1/4 cap screw and the two washers.
7. Install the pivot, spider, and the piston assemblies in the piston block. Install this assembly in the housing assembly. The piston shoes must be in contact with the cam plate. Be sure all the parts are in their proper position.
8. Clamp this assembly in a protected jaw vise with the open end of the housing up.
9. Install new gasket.
10. Install relief valves and springs into backplate.
11. Install backplate assembly. Install six cap screws and torque to 27-31 ft. lbs.

MAINTENANCE

POSSIBLE TROUBLE	CAUSES	REMEDIES
System will not operate in either direction.	Oil supply low. Oil Filter clogged. Oil too heavy. Drive Coupling broken.	Check oil level and fill. Replace Filter Element. Use proper viscosity oil. Inspect Coupling for sheared Spline Spline or Key.
System noisy.	Air in system due to low oil level. Loose Suction Line. Clogged Suction Filter. Internal Pump or Motor damage.	Fill in reservoir to sight glass. Tighten Fittings. Replace Filter Element. Disassemble, inspect, and repair.
Sluggish response to acceleration	Air in system. Internal Pump or Motor wear or damage.	See Step 1A, 1B, 1C, 2B Disassemble, inspect, and repair.



MAINTENANCE

Hydraulic Motor Disassembly

1. Clean outside of unit thoroughly. Refer to Hydraulic Motor illustration in the Parts Listing section.
2. Clamp shaft in a protected jaw vise with backplate end up.
3. Remove six cap screws from backplate.
4. Use a plastic mallet and tap the backplate to loosen it.
5. Remove o-ring from backplate.
6. Remove the complete piston block assembly from the housing assembly.
7. Remove piston assemblies, spider, and pivot from piston block assembly.
8. The piston block assembly need not be disassembled unless the pins or spring is damaged.



The following procedure should be used if the spring is to be removed from the piston block. The spring is highly compressed and the snap ring should not be removed without compressing the spring.

The following parts will be needed to disassemble the piston block:

- 2 ea. 3/8 I.D. x 1-1/8 O.D. flat washer
- 1 ea. 3/8 I.D. x 3-1/4 N.C. capscrew
- 1 ea. 3/8 N.C. nut

Place one of the flat washers over the 3/8 x 3-1/4 capscrew and place this through the center of the piston block. Place the other washer over the capscrew and let it rest on the three pins. Screw nut on and compress the spring inside the piston block. Use a pair of snap ring pliers and remove the internal snap ring. Remove the bolt and two washers. Remove the two washers, spring, three pins, and pin keeper.

9. Remove thrust race from housing.
10. Remove snap ring from housing.
11. Remove shaft seal from housing.
12. Remove washer from housing.
13. Remove drive shaft from housing.
14. Remove the two snap rings, thrust washers, and thrust bearing, from drive shaft.

MAINTENANCE

Inspection

1. Wash all parts thoroughly in a suitable solvent.
2. Examine needle bearings in housing and backplate.
3. Inspect thrust washers and thrust bearing. All surfaces should be free of any signs of wear or fretting.
4. Inspect spider and pivot; conical surfaces should be free of wear and score marks.
5. Inspect the pistons: the O.D. surface should be smooth and free of scoring. The shoes should be snug fit to the piston. The face of the shoes should be flat and free of scoring and flaking. DO NOT LAP PISTON SHOES.
6. Inspect the piston block; the bores should be free of scoring. The surface that contacts the backplate should be smooth and free of grooves or metal build-up. Do not lap piston block.
7. Inspect the thrust race; the surface should show no signs of scoring or grooves.
8. Inspect the flat surface on the backplate; it should be free of excessive scoring or metal build-up. DO NOT LAP BACKPLATE.
9. Inspect the drive shaft for fretting in the bearing areas. Check spline area for twisted or broken teeth. If keyed shaft, check for cracked or chipped keyway.

Reassembly

1. Use filtered system oil to lubricate all critical moving parts before assembly.
2. Install one snap ring in rear groove of drive shaft. Install one thrust washer, thrust bearing, and second thrust washer on drive shaft. Install second snap ring in front groove on drive shaft.
3. Replace needle bearing in housing if necessary. Install shaft in housing assembly and install washer. Oil O.D. of new shaft seal and press into position. Retain with snap ring.
4. Compress pin keeper and install in the spline area of the piston block.
5. Install the three pins in the special grooves of the spline and with head end of pin toward inside of block.
6. Install one washer, spring, and second washer. Use the two 3/8 I.D. washers and the 3/8 x 3-1/4 cap screw to compress the spring and retain with snap ring. Remove the 3/8 x 3-1/4 capscrew and two washers.
7. Install the pivot, spider, and the piston assemblies in the piston block assembly.
8. Lubricate thrust race and install in housing assembly.
9. Install piston block assembly in housing assembly. The piston shoes must contact the thrust race. Be sure all parts are in their proper position.
10. Install new needle bearing in backplate if necessary.
11. Install new o-ring on backplate.
12. Install backplate on housing.
13. Install six capscrews and torque 15-18 ft. lbs.
14. On through shaft type assembly, install shaft seal and snap ring in backplate. Install key in driveshaft.

MAINTENANCE

Troubleshooting

POSSIBLE TROUBLE

CAUSES

REMEDIES

Motor turns while unloaded but slows down or stops when load is applied

Scored backplate.

Scored or worn piston shoes.

Low Relief Valve pressure.

Remove backplate and examine surface condition of flat area; if scored, replace backplate. DO NOT LAP. Disassemble motor, examine condition of shoes on pistons; replace pistons as a complete set if necessary. DO NOT LAP
Check Relief Valve for proper pressure setting; adjust or replace Relief Valve.

Motor will not turn.

Severely scored backplate.

Disassemble motor completely. Inspect all parts, clean all parts, replace all worn parts and flush hydraulic system.

Motor free wheels.

Oil-flow and pressure shut off going to motor.

When the hydraulic system is shut off, either by shutting off the engine on a closed loop system or returning the control valve spool to neutral on an open center system, the motor will free-wheel after it has leaked off. This is inherent in the design. On a closed loop or propulsion system, the motor will not free-wheel as long as charge pressure is maintained to and from the motor.

Excessive Case Drain flow.

Excessive internal wear in motor.

Disassemble motor; inspect parts and replace as necessary. Case Drain flow should not exceed 1.5 GPM at full pressure.

MAINTENANCE

MAINTENANCE

CONTROL CIRCUIT

Lift and Tilt Cylinders

Hydraulic cylinders change the position of the cutter unit. The lift cylinder raises and lowers the unit by changing

position of the lift frame. To lift unit, oil is supplied to rod side of cylinder. Gravity lowers unit when lift levers are in "DOWN" position.

The tilt cylinder changes the angle of the cutter unit. Oil is supplied to both ends of the cylinder and provides power to tilt the unit up or down. The unit can be tilted to the full vertical position for transport.

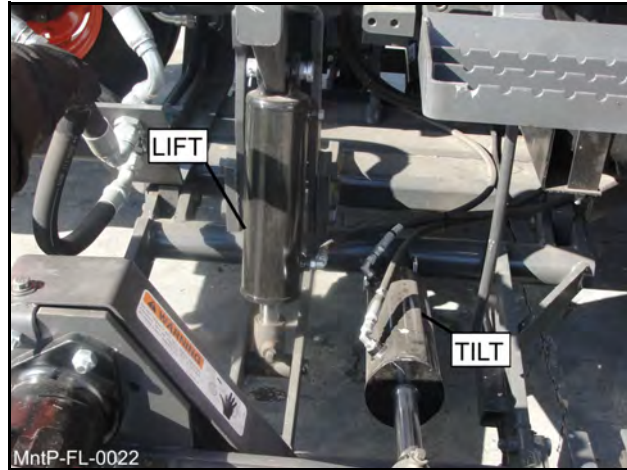

Lift Cylinder (3-1/4" O.D.)

Tilt Cylinder (3-3/4" O.D.)

Disassembly or Lift or Tilt Cylinder

For part numbers and illustration, refer to the Parts Listing section.

1. Disconnect hoses at cylinder. Cap all hoses to prevent fluid contamination. Remove cylinder from unit.
2. Remove reducer bushing and snap ring which retains the rod guide. Remove rod guide, rod, and piston. Remove guide and piston from rod.
3. Replace all "O" rings, back-up washers, and rod wiper. Inspect rod, guide, piston, and body for damage.
4. Clean inside of cylinder with mineral spirits. DO NOT wipe dry; air dry instead. Lint, dirt, and, grit can cause immediate or premature failure.
5. Lubricate all parts with clean hydraulic oil and reassemble.

Cylinder Rod Maintenance

It is important to visually inspect the hydraulic cylinder rods daily before use. It is highly recommended that while the machine is stored or getting very little use that a protectant is applied to the hydraulic cylinder rods to prevent degradation. If the machine receives more frequent use, be sure to fully cycle each cylinder function so that the cylinder rod is coated by the systems hydraulic fluid. Depending on your operating environment it may be necessary, under normal operating conditions, to apply a protective lubricant to the cylinder rods for protection against rust and pitting. Hydraulic fluid may provide a suitable amount of protection, but remember any protectant can attract dust and debris so attention must be given to the cylinder rods daily. Also remember that any other protectant must be compatible with hydraulic fluid. Alamo Industrial is not responsible for rust or pitting of the cylinder rod due to weather exposure or impacts from normal operation or mounting. If hydraulic cylinders and or the cylinder rods are damaged as a result of the rods rusting or pitting, the hydraulic cylinders and rods will not be covered under warranty by Alamo Industrial.

MAINTENANCE

MAINTENANCE

Hydraulic Component Maintenance Schedule

Component	Installation	Hours of Operation											
		200	400	600	800	1000	1200	1400	1600	1800	2000	2200	
Pump Drive Shaft Check and Lubricate	x	x	x	x	x	x	x	x	x	x	x	x	x
Pump Mounting Bolt torque check (Inspect Daily)	x	x	x	x	x	x	x	x	x	x	x	x	x
Charge Pump Filter	Installation	x			x					x			
Pressure Filter to the Control Valve	Installation	x			x					x			
Return Canister Filter Element	Installation	x			x					x			
Hydraulic Oil Change	Installation	x								x			
Hydraulic Oil Particle Count Testing	x	x			x					x			
Hydraulic Tank Breather Filter	Installation	Inspect								Replace			
Hydraulic Tank Suction Screen	Installation	Inspect								Inspect			
Hydraulic Hose Inspection/Replacement	Installation	Inspect	Inspect	Inspect	Inspect	Inspect	Inspect	Inspect	Inspect	Inspect	Inspect	Inspect	Inspect
Cooling Fan Clean and Inspect	Daily	Daily	Daily	Daily	Daily	Daily	Daily	Daily	Daily	Daily	Daily	Daily	Daily
Check Hydraulic Fluid Level (Inspect Daily)	Daily	Daily	Daily	Daily	Daily	Daily	Daily	Daily	Daily	Daily	Daily	Daily	Daily
Mower Blades Replace (INSPECT DAILY)		x	x	x	x	x	x	x	x	x	x	x	x
Blade Bolts Replace (INSPECT DAILY)		x	x	x	x	x	x	x	x	x	x	x	x
Blade Bar Assembly Replace	Installation					x						x	
Spindle Lube Replacement (INSPECT DAILY)	x					x						x	
Spindle Bearing Pre-load Inspection	x	x	x	x	x	x	x	x	x	x	x	x	x
Mower Debris Guard Inspect/Replace	x	x	x	x	x	x	x	x	x	x	x	x	x
Pivot Point Lubrication	Daily	Daily	Daily	Daily	Daily	Daily	Daily	Daily	Daily	Daily	Daily	Daily	Daily
King Pin Bearing Replacement	Installation									x			
Pivot Pin Bearing replacement (Steel)	Installation									x			
Pivot Pin Bearing Replacement (Fiber)	Installation						x					x	
Inspect Operation And Safety Decals Replace when faded, torn or missing.	x	x	x	x	x	x	x	x	x	x	x	x	x

Repeat the Maintenance Schedule based on the hours indicated for the life of the machine

Hydraulic Gear Pump

The gear pump, mounted to the pump mount and driven by the crank shaft pulley, produces oil flow for the control circuit. The gear pump inlet is connected, via a hose, to the reservoir which supplies control circuit oil. A high pressure hose connects the pump outlet to the sectional control valve inlet.

NOTE: The gear pump is not used when tractor hydraulics are used to power the control circuit.



MntP-FL-0018

MAINTENANCE

Sectional Control Valve

The control valve directs oil flow from the gear pump to the hydraulic cylinders. In the "HOLD" position, the spool blocks oil flow to the cylinders which prevents movement, and directs oil through the valve back to the reservoir.

When the spool is shifted, oil flows to one side of the cylinder while the other side is opened to the return line. The cylinder rod then moves in or out and changes the cutter unit's position.

In the "FLOAT" position, the spool will open both sides of the cylinder to the return line. The cylinder rod is then free to move since oil can enter or leave either side of the cylinder.

There are two valve sections for each side of the tractor. One is for TILT, one is for LIFT. The sections are bolted together between an inlet and an outlet section. The LIFT section has three positions: UP, HOLD and DOWN & FLOAT. The TILT section has four positions: UP, HOLD, OUT and FLOAT.

A pressure relief valve is mounted in the inlet section of the valve. When a cylinder is bottomed, the relief valve will open and allow oil from the gear pump to return to the reservoir.



MAINTENANCE

Checking Relief Valve Pressure

1. To check the relief valve pressure setting, remove inlet hose at the control valve. Install a tee fitting and reconnect the hose to a pressure gauge.
2. Check for proper tension on front drive belts (1/4 inch play at midpoint).
3. Start engine and run at low idle.
4. Raise the Tilt cylinder and note the pressure when the cylinder bottoms.
5. The pressure should be the same on both circuits, 1200 psi. If the pressure is 1200 psi on one and not on the other, the relief valve and the pump are working fine. The problem would be somewhere else.
6. If pressure is low on both circuits, adjust relief valve. Remove hex cap, loosen lock nut (if present) and turn adjusting screw clockwise.
7. If the pressure does not increase, remove the relief valve and inspect it. If the valve is good, the gear pump is worn.

MAINTENANCE

External Coil Slip Disk Replacement

A. TO DISASSEMBLE EXTERNAL COIL SPRING CLUTCH (Figure Mnt-FL-0024)

Before beginning disassembly, remove or fold shields out of the way and clean off dirt and trash from the area.

1. Remove two Attaching Bolts (6). Remove Clutch Assembly from shaft of Gearbox. Leave Driveline or Driveline Half attached to Clutch.
2. Loosen six Adjusting Bolts (1). **LOOSEN EACH BOLT A FEW TURNS AT A TIME - NOT ALL AT ONCE.** Continue in rotation until Nuts are loose. Remove these Bolts. Flange Yoke (9) will slide off. On Clutches that have Dust Shields (11), Shields will slide off with Flange Yoke. **Note: Some types do not have Dust Shields.**
3. On the opposite side, Outer Flange (2) will slide off which will allow Clutch Plate (3) to slide over notches on outside diameter of Clutch Body (5).
4. Remove Plate with six bolt holes (7). **Note: Bolts (1) go through these holes.**
5. Remove the four Friction Disks (4) and discard. **DO NO RE-USE.**

B. TO CLEAN AND INSPECT

1. Inspect all components for rust, wear, or damage. Check Spacer (8) for scoring or excessive wear. Clean Clutch Plates and Drive Plates with a wire brush as required to remove any rust.

C. TO REASSEMBLE

1. After all parts have been inspected, cleaned or replaced as necessary, replace components in reverse order from disassembly **USING THE NEW, IMPROVED DISKS.** Do not tighten the six Adjusting Nuts and Bolts (1) until assembly is complete.

D. TO ADJUST

To adjust Slip Clutch, tighten Bolts (1) until the Nut makes contact with Compression Spring (10).

1. After all six Bolts have been assembled so that Nuts contact Springs, mark the position of the top flat on each Nut. Tighten Nuts 1-3/8 turns as follows: **Do NOT** tighten one bolt completely. Tightening as shown in rotation will put equal pressure all the way around on Friction Disks and Drive Plates.
 - a. Tighten the Nuts (1) one-half turn in rotation.
 - b. Tighten one-half turn again until the marks on the Nuts are on top as in the beginning.
 - c. Then, carefully tighten 3/8 of a turn. As a double check, the Springs should now be **COMPRESSED TO 1-11/32" (1.34") TO 1-5/16" (1.31") long.**
1. Re-assemble Clutch to Gearbox. Tighten Bolts (6) securely.
2. Clutch slips too easily, **STOP PTO AT ONCE.** Tighten each Adjusting Nut (1) **NO MORE THAN ¼ TURN AT A TIME. NEVER TIGHTEN SPRINGS SHORTER THAN 1-9/32" (1.28") LONG EVEN AFTER DISK WEAR.**

NOTE: EXCESSIVE SLIPPING WILL BURN UP DISKS AND SLIP CLUTCH TO THE POINT WHERE THE CLUTCH IS NOT REPAIRABLE. HOWEVER, EXCESSIVE TIGHTENING WILL PREVENT THE SLIP CLUTCH FROM SLIPPING AND CAN LEAD TO FAILURES OF DRIVETRAIN COMPONENTS WITH RESULTING DOWNTIME.

E. TO REPLACE SHIELDS

1. Make certain that all Driveline Canopy Shields are in good repair and rotate smoothly on the Drivelines. Replace Bearings and/or Integral Shields if necessary.
2. Re-install Gearbox Canopy Shields with the same hardware and tighten securely.

MAINTENANCE

MAINTENANCE

Slip Clutch

A slip clutch is incorporated in the PTO driveline. It is designed to slip, absorb the shock load, and protect the driveline.

After the first hour of operation, the slip clutch should be checked for overheating. After this first check, the slip clutch should be checked weekly or anytime there is overheating. To adjust the slip clutch, tighten the spring bolts 1/8 (maximum) turn at a time. Bolts should NEVER be adjusted to the point where the springs are compressed solid. Minimum spring length is 1-1/8".

The slip clutch should be checked periodically and adjusted to compensate for wear. The lining plates are 1/8" thick when new. Replace after 1/32" wear. If the mower has been idle for an extended period of time, or in wet weather, before operating check to be sure the friction lining plates are not frozen or rusted together. Should this freezing occur refer to the procedure described in the "Seasonal Clutch Maintenance" section on the next page.

There are four friction lining plates in the slip clutch. These should be checked weekly for oil or grease, wear, and moisture which could cause corrosion on the drive plates.

TANK FILLING INSTRUCTIONS

USE Tractor Hydraulic Oil only

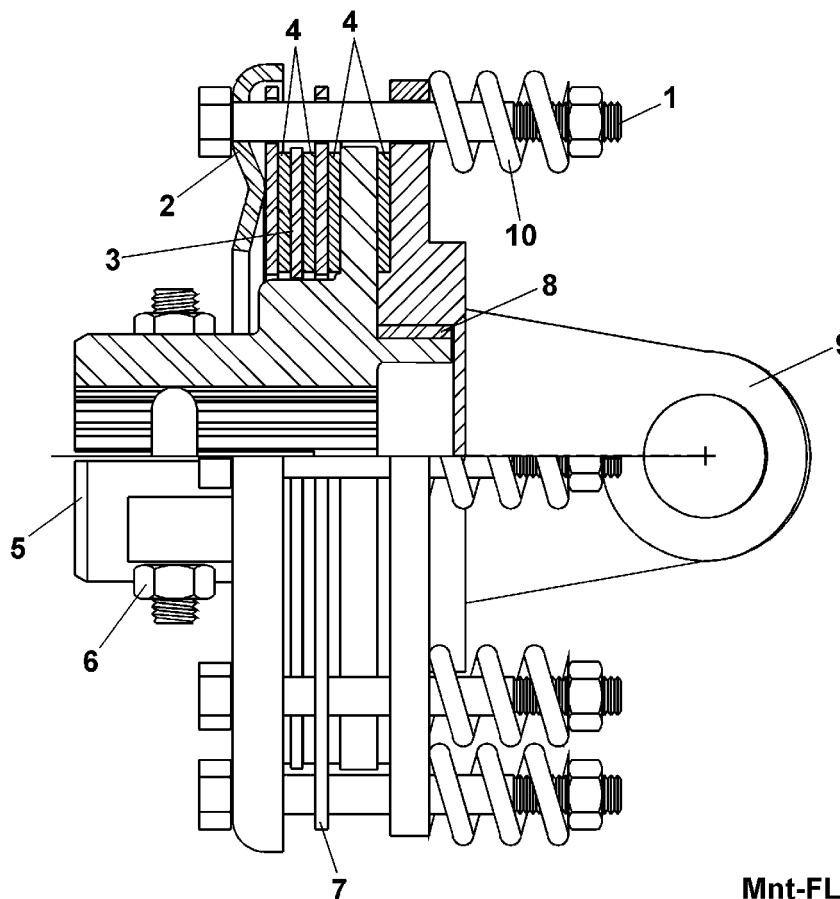

Mnt-FL-0024

MAINTENANCE

SEASONAL CLUTCH MAINTENANCE

It is important that the clutch lining plates slip when an obstacle or load heavier than clutch setting is encountered. Therefore, if the machine sits outside longer than 30 days and is exposed to rain and/or humid air it is important to make sure that the clutch lining plates are not rusted/corroded together. Before using the mower use the following procedure to make sure the clutch will slip and give the overload protection required.

1. Loosen nuts on springs until the springs can freely rotate, yet remain secure on bolts.
2. Attach mower to tractor and start the tractor. Set the engine speed at 1200 RPM.
3. Mark outer plates as shown in.
4. Engage the PTO (approximately one second) and then quickly disengage it. The friction lining plates should break loose (check the mark).
5. Turn tractor off and tighten the nuts on the springs to their original position of 1-5/16" compressed spring length.

A double wing Interstater with 74" wing mowers will require approximately 26 gallons of oil to fill the hydraulic tank, hoses, cylinders and cooling tubes in the mower deck. An Interstater with 60" wings will require less oil and with 88" wings will require more oil. The Hydraulic tank only holds 15 gallons of oil and you can not add enough oil to the tank the first time to completely fill the system. Oil should be changed after the first 200 hours of operation and every 400 hours of 12 months of operation thereafter.

The following filling instructions must be carefully followed to prevent pump cavitation and instant pump failure.

1. After the Interstater mower is completely assembled to the tractor and with the wings on the ground, fill the mower hydraulic tank above the oil level sight gauge approximately 5" or 1" below the top of the tank.
2. Start the tractor and run it for 30 to 45 seconds and then turn it off.
3. Check the oil level in the sight gauge. If no oil is seen, add oil to bring the level up to the sight gauge.

NOTE: Do not fill the tank with oil above the level of the sight gauge after the first filling. Overfilling the tank with oil after the initial filling may result in oil being discharged through the air filter on top of the hydraulic tank.

4. Start the tractor and run it for 2 minutes and then turn it off.
5. Again check the oil level in the sight gauge. If the oil level is in the sight gauge, the unit is ready to run. If no oil is seen, add oil to bring the level up to the sight gauge.
6. Repeat steps 4 and 5 as required until the oil level stabilizes at the level of the sight gauge.

MAINTENANCE

MAINTENANCE

Proper Torque for Fasteners

The chart lists the correct tightening torque for fasteners. When bolts are to be tightened or replaced, refer to this chart to determine the grade of bolts and the proper torque except when specific torque values are assigned in manual text.

RECOMMENDED TORQUE IN FOOT POUNDS UNLESS OTHERWISE STATED IN THE MANUAL *

NOTE: These values apply to fasteners as received from supplier, dry or when lubricated with normal engine oil. They do not apply if special graphited or molydisulphide greases or other extreme pressure lubricants are used. This applies to both UNF fine and UNC coarse threads.

TORQUE SPECIFICATIONS - DRY TORQUE

Proper torque for American fasteners.
Recommended Torque in Foot Pounds (Newton Meters). *

AMERICAN
Bolt Head Markings



SAE Grade 2
(No Dashes)



SAE Grade 5
(3 Dashes)



SAE Grade 8
(6 Dashes)



All Capscrews
SAE Grade 8

WRENCH SIZE (IN.) "A"	BOLT DIAMETER (IN.) "B" AND THREAD SIZE	SAE GRADE 2	SAE GRADE 5	SAE GRADE 8
7/16	1/4 - 20 UNC	6 (7)	8 (11)	12 (16)
7/16	1/4 - 28 UNF	6 (8)	10 (13)	14 (18)
1/2	5/16 - 18 UNC	11 (15)	17 (23)	25 (33)
1/2	5/16 - 24 UNF	13 (17)	19 (26)	27 (37)
9/16	3/8 - 18 UNC	20 (27)	31 (42)	44 (60)
9/16	3/8 - 24 UNF	23 (31)	35 (47)	49 (66)
5/8	7/16 - 14 UNC	32 (43)	49 (66)	70 (95)
5/8	7/16 - 20 UNF	36 (49)	55 (75)	78 (106)
3/4	1/2 - 13 UNC	49 (66)	76 (103)	106 (144)
3/4	1/2 - 20 UNF	55 (75)	85 (115)	120 (163)
7/8	9/16 - 12 UNC	70 (95)	109 (148)	153 (207)
7/8	9/16 - 18 UNF	79 (107)	122 (165)	172 (233)
15/16	5/8 - 11 UNC	97 (131)	150 (203)	212 (287)
15/16	5/8 - 18 UNF	110 (149)	170 (230)	240 (325)
1-1/8	3/4 - 10 UNC	144 (195)	266 (360)	376 (509)
1-1/8	3/4 - 16 UNF	192 (260)	297 (402)	420 (569)
1-5/16	7/8 - 9 UNC	186 (225)	430 (583)	606 (821)
1-5/16	7/8 - 14 UNF	184 (249)	474 (642)	668 (905)
1-1/2	1 - 8 UNC	250 (339)	644 (873)	909 (1232)
1-1/2	1 - 12 UNF	274 (371)	705 (955)	995 (1348)
1-1/2	1 - 14 UNF	280 (379)	721 (977)	1019 (1381)
1-11/16	1-1/8 - 7 UNC	354 (480)	795 (1077)	1260 (1745)
1-11/16	1-1/8 - 12 UNF	397 (538)	890 (1208)	1444 (1957)
1-7/8	1-1/4 - 7 UNC	500 (678)	1120 (1518)	1817 (2462)
1-7/8	1-1/4 - 12 UNF	553 (749)	1241 (1682)	2013 (2728)
2-1/16	1-3/8 - 6 UNC	655 (887)	1470 (1992)	2382 (3228)
2-1/16	1-3/8 - 12 UNF	746 (1011)	1672 (2266)	2712 (3675)
2-1/4	1-1/2 - 6 UNC	870 (1179)	1960 (2642)	3161 (4283)
2-1/4	1-1/2 - 12 UNF	979 (1327)	2194 (2973)	3657 (4820)

Proper torque for Metric fasteners.
Recommended torque in Foot Pounds (Newton Meters) *

METRIC

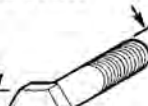

Numbers appearing on bolt heads indicate ASTM class.





*Use 75% of the specified torque value for plated fasteners. Use 85% of the specified torque values for lubricated fasteners.

WRENCH SIZE (mm) "A"	BOLT DIA. (mm) "B"	ASTM 4.6	ASTM 8.8	ASTM 9.8	ASTM 10.9
8	5	1.8 (2.4)		5.1 (6.9)	8.5 (8.8)
10	6	3 (4)		8.7 (12)	11.1 (15)
13	8	7.3 (10)		21.1 (29)	27 (37)
16	10	14.5 (20)		42 (57)	53 (72)
18	12	25 (34)	74 (100)	73 (99)	93 (128)
21	14	40 (54)	118 (160)	116 (157)	148 (201)
24	16	62 (84)	167 (226)	161 (245)	230 (312)
30	20	122 (165)	325 (440)		449 (608)
33	22		443 (600)		611 (828)
36	24	211 (286)	563 (763)		778 (1064)
41	27		821 (1112)		1138 (1542)
46	30	418 (566)	1119 (1516)		1547 (2096)

Mnt-B-0005

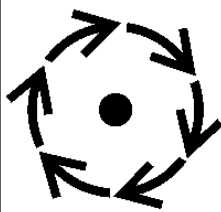
SEGURIDAD

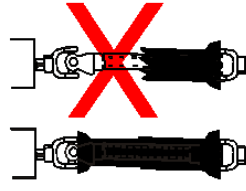
SEGURIDAD

⚠️ ADVERTENCIA		⚠️ WARNING	
<p style="text-align: center;">540 RPM</p> <p style="text-align: center;">OPERE ESTA MÁQUINA LA VELOCIDAD DE PTO (TOMA DE FUERZA O BARRA GITATORIA) DEL TRACTOR DE 540 RPM. El exceso de velocidad de PTO puede causar el fracaso de componente que resultara en lesión. ROTACION DE PTO DEL TRACTOR: EN SENTIDO HORARIO D547 SP</p>		<p style="text-align: center;">540 RPM</p> <p style="text-align: center;">OPERATE THIS MACHINE AT TRACTOR PTO SPEED ONLY. Overspeeding PTO may cause component failure resulting in bodily injury. TRACTOR PTO ROTATION: CLOCKWISE</p>	
⚠️ PELIGRO		⚠️ DANGER	
<p style="text-align: center;">PARA EVITAR LESION SERIA O MUERTE POR CONTACTO A LA LINEA DE CONDUCCION, SEPARACION DE LINEA DE CONDUCCION O EL FRACASO DEL EJE DE PTO:</p> <ul style="list-style-type: none"> • PARE, MIRE Y ESCUCHE por el movimiento de rotación antes de acercarse al implemento. • MANTENGASE ALEJADO y MANTENGA manos, pies y cuerpo LEJOS de partes girando, hasta que todos los elementos de movimiento se han parado. • SIEMPRE apague la Toma De Fuerza (Barra Gitatoria) antes de desmontar. • NO opere si las cubiertas de Toma De Fuerza (Barra Gitatoria) estan dañadas. • EMPUJE Y JALE el yugo hasta que el collar de fijación hace clic y el yugo se trabaja en lugar. • REVISE las guardias de línea de conducción por giración libre y suficiente traslape para evitar áreas sin cobertura. • NO UTILICE UN ADAPTOR PARA LA TOMA DE FUERZA (Barra Gitatoria). <p style="text-align: right; font-size: small;">D547_1</p>	 <p style="text-align: center;">PTO (Barra Gitatoria)</p>  	<p style="text-align: center;">TO AVOID SERIOUS INJURY OR DEATH FROM DRIVELINE CONTACT, DRIVELINE SEPARATION OR PTO SHAFT FAILURE:</p> <ul style="list-style-type: none"> • STOP, LOOK and LISTEN for rotating motion before approaching implement. • STAY AWAY and KEEP hands, feet and body AWAY from rotating parts until all moving elements have stopped. • ALWAYS shut off PTO before dismounting. • DO NOT operate if PTO shields are damaged or missing. • PUSH AND PULL on yoke until collar clicks and locks yoke in place. • CHECK driveline guards for free rotation and sufficient overlap to avoid unshielded areas. • DO NOT USE PTO ADAPTER 	

SEGURIDAD

SEGURIDAD

<p>⚠️ ADVERTENCIA</p>		<p>⚠️ WARNING</p>	
<p>PARA EVITAR INCENDIOS DE EQUIPO Y CÉSPED:</p> <ul style="list-style-type: none"> • QUITE el césped o escombros de engranajes, líneas de conducción y cubiertas. <p>PARA EVITAR INCENDIOS POR IGNICIÓN:</p> <ul style="list-style-type: none"> • NO PERMITA QUE LAS LAMINAS CONTACTEN piedras, metal o objetos sólidos. <p>D708</p>			
<p>TO AVOID EQUIPMENT AND GRASS FIRES:</p> <ul style="list-style-type: none"> • CLEAR AWAY grass or debris from slip clutches, gearboxes, drivelines and decks. <p>TO AVOID FIRE IGNITION:</p> <ul style="list-style-type: none"> • DO NOT ALLOW BLADES TO CONTACT rocks, metal or solid objects. 			

<p>⚠️ PELIGRO</p>		<p>⚠️ DANGER</p>	
<p>FALTA EL CUBIERTA NO OPERE</p>		<p>GUARD DO NOT OPERATE</p>	
			
<p>⚠️ PELIGRO</p>		<p>⚠️ DANGER</p>	



D546 SP

SEGURIDAD

SEGURIDAD

 DANGER	 PELIGRO
<p>Si vous ne savez pas lire le français: avant d'utiliser l'équipement, demandez à une personne de vous traduire les messages de sécurité ou allez sur le site Internet pour voir la traduction des autocollants et des messages de sécurité.</p>	<p>Si no puede leer inglés: antes de poner en funcionamiento este equipo, solicite que alguien le traduzca los mensajes de seguridad o vaya al sitio web para consultar los mensajes de seguridad y las etiquetas ya traducidos.</p>
<p>Manuel de l'Opérateur</p>   <p>www.algqr.com/aff</p>	<p>El Manual del Operador Seguridad video</p>    <p>www.algqr.com/avs</p>

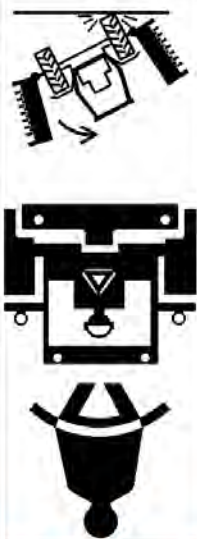
 GEFAHR	 PERIGO
<p>Falls Sie Deutsch nicht lesen können: Lassen Sie sich, bevor Sie das Gerät in Betrieb nehmen, die Sicherheitshinweise von einer geeigneten Person in Ihre Sprache übersetzen. Oder suchen Sie auf unserer Website nach Übersetzungen von Schilderaufschriften und Sicherheitshinweisen.</p>	<p>Caso você não leia inglês: antes de operar o equipamento, peça para alguém traduzir as mensagens de segurança ou visite a web e obtenha tais mensagens ou os decalques traduzidos.</p>
<p>Benutzerhandbuch</p>   <p>www.algqr.com/atfg</p>	<p>Manual do Operator</p>   <p>www.algqr.com/atfp</p>

<p>PARA EVITAR LESION SERIA Y MUERTE DURANTE LA TRANSPORTACION:</p> <ul style="list-style-type: none"> • SIEMPRE ABROCHE el cinturón de seguridad. • COLOQUE el brazo seguramente en transporte y apague el interruptor principal. • VERIFIQUE QUE EL SMV, reflectors, y luces intermitentes de advertencia pueden ser vistos claramente por detras de la unidad. • PRIENDA las luces intermitentes de advertencia. <p>PARA EVITAR LA PERDIDA DEL CONTROL DE TRANSPORTACION:</p> <ul style="list-style-type: none"> • NO remolque en velocidades arriba de 20 mph. • REDUZCA LA VELOCIDAD en inclinaciones y en vueltas y en pobres condiciones de remolque. <p>D699_1</p>		<p>TO AVOID SERIOUS INJURY AND DEATH DURING TRANSPORTATION:</p> <ul style="list-style-type: none"> • ALWAYS BUCKLE UP seat belt. • PLACE wing securely in Transport latch and turn off master switch. • CHECK SMV sign, reflectors and warning lights for visibility behind unit. • TURN ON tractor flashing warning lights. <p>TO AVOID LOSS OF TRANSPORTATION CONTROL:</p> <ul style="list-style-type: none"> • DO NOT travel at speeds over 20 mph. • REDUCE SPEED on inclines, in turns and in poor weather conditions.
<p>PARA EVITAR LESION SERIA Y MUERTE DURANTE LA OPERACION:</p> <ul style="list-style-type: none"> • NO levante el implemento al estar en pendientes pronunciados. • MANTENGASE ALEJADO DE agujeros y zanjas blandas. • MANTENGA SIEMPRE el 20% de peso del tractor en las ruedas delanteras. • NO comience ni acelere repentinamente. • MANTENGA la unidad, por lo menos 10 pies de distancia de las líneas eléctricas y líneas de tubo. <p>D699_2</p>		<p>TO AVOID SERIOUS INJURY AND DEATH DURING OPERATION:</p> <ul style="list-style-type: none"> • DO NOT lift implement while on steep slopes. • KEEP AWAY from soft ditch banks and holes. • ALWAYS MAINTAIN 20% of tractor weight on front wheels. • DO NOT start or accelerate suddenly. • KEEP mower AT LEAST 10 FEET AWAY from electric lines and pipe lines.
<p>PARA EVITAR INCENDIOS DE EQUIPO Y CÉSPED:</p> <ul style="list-style-type: none"> • QUITE el césped y escombros de las líneas hidráulicas, circuito, y las cubiertas. • NO PERMITA QUE LAS CUCHILLAS CONTACTEN piedras, metal o objetos solidos. • NO PERMITA QUE EL ACEITE CAIGA en el equipo o componentes calientes. <p>D699_3</p>		<p>TO AVOID EQUIPMENT AND GRASS FIRES:</p> <ul style="list-style-type: none"> • CLEAR AWAY grass or debris from hydraulic lines, circuits and decks. • DO NOT ALLOW BLADES TO CONTACT rocks, metal or solid objects. • DO NOT ALLOW OIL TO SPRAY on hot equipment or components. <p>D699_3</p>

	<p>▲ WARNING</p> <p>To Avoid Inadvertent Unfolding and Serious Injury during Transportation:</p> <ul style="list-style-type: none"> • Transport with lever in neutral position.
	<p>▲ ADVERTENCIA</p> <p>Para Evitar Despliegue Inadvertido y Lesion Seria durante Transportacion:</p> <ul style="list-style-type: none"> • Transporte con la palanca en la posición neutral.



D685

<p>▲ PELIGRO</p>	<p>▲ DANGER</p>
<p>FALTA EL CUBIERTA NO OPERE</p>	<p>GUARD DO NOT OPERATE</p>
	
<p>▲ PELIGRO</p>	<p>▲ DANGER</p>

D646

SEGURIDAD

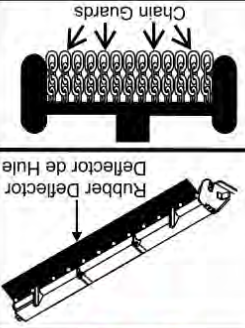
SEGURIDAD

⚠ DANGER		⚠ PELIGRO	
THROWN OBJECT HAZARD		RIESGO DE OBJETOS LANZADOS	
<p>TO AVOID SERIOUS INJURY OR DEATH:</p> <ul style="list-style-type: none"> • DO NOT OPERATE if Thrown Object Shielding is damaged or missing. • Maintain Rubber Deflectors in good condition. • Inspect Rubber Deflectors frequently. 		<p>PARA EVITAR LESION SERIA O MUERTE:</p> <p>NO OPERE si la Cubierta de Objetos Lanzados esta dañada o falta.</p> <p>Mantenga Los Deflectores de Hule en buenas condiciones.</p> <p>Inspeccione Los Deflectores de Hule con frecuencia.</p> <p>D626 SP</p>	
 <p>Chain Guards</p> <p>Rubber Deflector</p> <p>Deflector de Hule</p>			

⚠ DANGER		⚠ PELIGRO	
Crushing Hazard - Injury or Death		Riesgo de Aplastamiento Lesion o Muerte	
<p>TO AVOID SERIOUS INJURY OR DEATH:</p> <ul style="list-style-type: none"> • STAND CLEAR when removing transport latch, lowering or raising wings. • CLEAR AREA of bystanders before lowering implement wings. • IMPLEMENT CAN FALL from hydraulic failure or accidental operation of controls. • BLOCK UP and securely support equipment before putting hands, feet or body under raised equipment or lifted components. • SECURELY ENGAGE transport latch before transportation or working under wing. • FILL CYLINDERS with oil before attempting to lower implement wings. • DO NOT OPERATE in transport position or with wings off ground. 		<p>PARA EVITAR LESION SERIA O MUERTE:</p> <ul style="list-style-type: none"> • MANTENGASE LEJOS al quitar el cierre de transporte, bajando y devantando las alas. • DESOCUPE EL AREA de personas presentes antes de bajar las alas del implemento. • EL IMPLEMENTO PUEDE CAER del fracaso hidráulico o por operación accidental de controles. • BLOQUEE y soporte con seguridad antes de poner manos, pies o cuerpo debajo del equipo de componentes levantados. • CON SEGURIDAD ACTIVE el cierre de transporte antes de la transportation o trabajar debajo de las alas. • LLENE LOS CILINDROS con aceite antes de intentar de bajar las alas del implemento. • NO OPERE en posición de transporte o con las alas devantadas del la tierra. <p>D698</p> 	
			

SEGURIDAD

<p>ADVERTENCIA</p> <p>Cáncer y Daño Reproductivo</p> <p>www.P65Warnings.ca.gov</p>	<p>WARNING</p> <p>Cancer and Reproductive Harm</p> <p>www.P65Warnings.ca.gov</p>
<p>IMPORTANTE</p> <p>ESTE CONSCIENTE SEA ENTRENADO ESTE ALERTO Antes de Funcionar ESTE VIVO Cortacésped</p> <p>Para prevenir lesiones graves a usted y/o personas presentes, sea entrenado en la Práctica de Segar Seguro. Compañías de Alamo Group, Alamo Industrial, Bush Hog, M&W, Rhino, Schulte y Tiger así como AEM y FEMA proporcionan material para entrenar que es esencial para su seguridad y la seguridad de otros al operar este equipo. Haga estos procedimientos de seguridad una parte importante de su día de trabajo. Lea y entienda el Manual de Operadores. No permita que personas sin entrenamiento funcionen este equipo. Contacte a su distribuidor, AEM (www.aem.org), FEMA Group (www.Alamo-Group.com) para la información sobre el material de entrenamiento o cursos que ofrecen el entrenamiento de Prácticas de Operación para Cortadoras.</p> <p>www.algqr.com/avs</p> 	<p>IMPORTANT</p> <p>BE AWARE Before Operating this Mower BE ALERT Before Operating this Mower BE ALIVE Before Operating this Mower</p> <p>To prevent serious injury to yourself and/or bystanders, be trained in Safe Mowing Practices. Alamo Group Companies, Alamo Industrial, Bush Hog, M&W, Rhino, Schulte, Tiger and Terrain King as well as AEM and FEMA provide training material that is critical for your safety and the safety of others when operating this equipment. Make these Safety Procedures an important part of every workday. Read and understand the Operator's Manual. Do not let untrained individuals operate this equipment. Contact your Dealer, AEM (www.aem.org), FEMA (314-878-2304), or Alamo Group (www.Alamo-Group.com) for information on training material or courses that provide training in Safer Operating Practices for Mowers.</p> <p>www.algqr.com/ave</p> 
<p>ADVERTENCIA</p> <p>Partes que no son auténticas pueden fallar catastróficamente. PARA EVITAR LESION SERIA O MUERTE:</p> <ul style="list-style-type: none"> ● Use SOLAMENTE las partes de reemplazo auténticas de ALAMO INDUSTRIAL. ● Partes que no son auténticas pueden fallar y causar condiciones peligrosas para el operador y personas presentes. Contacte a su distribuidor local o ALAMO INDUSTRIAL sobre partes de reparo a: 1502 E. Walnut, Seguin, TX 78155. www.algqr.com/aps Servicio al Cliente: 800-882-5762. Correo Electrónico: support@alamo-industrial.com 	<p>WARNING</p> <p>Non-genuine parts can fail catastrophically. TO AVOID SERIOUS INJURY OR DEATH:</p> <ul style="list-style-type: none"> ● ONLY use genuine ALAMO INDUSTRIAL replacement parts. ● Non-genuine parts can fail creating hazardous conditions for operator and bystanders. Contact local dealer or ALAMO INDUSTRIAL about repair parts at: 1502 E. Walnut, Seguin, TX 78155. Customer Service: 800-882-5762. Email: support@alamo-industrial.com 

SEGURIDAD

D816 SP

D816 SP_B

D564_2

D564_1

SEGURIDAD

SEGURIDAD

! DANGER	
Entanglement Hazard	
Mower head will start running when lowered if Mower ON/OFF Switch is ON.	
TO AVOID SERIOUS INJURY OR DEATH:	
• MAKE CERTAIN the ON/OFF SWITCH is OFF before lowering mower head.	
• CLEAR AREA of bystanders before lowering mower head.	
Mower head automatically shuts OFF when raised above 45°.	
	
! PELIGRO	
Riesgo de Enredamiento	
La Cabeza Cortadora empezará al bajar si el interruptor de ENCENDIDO/APAGADO de cortadora esta en la posición ENCENDIDO. PARA EVITAR LESION SERIA O MUERTE:	
• ESTE SEGURO que el INTERRUPTOR de ENCENDIDO/APAGADO esta en la posición APAGADO antes de bajar la cabeza cortadora.	
• DESOCUPE EL AREA de personas presentes antes de bajar la cabeza cortadora.	
La Cabeza Cortadora se APAGA automáticamente cuando es levantada arriba de 45°.	

D682

<p>! PELIGRO</p>			
			
<p>PARA EVITAR LESION SERIA O MUERTE:</p> <ul style="list-style-type: none"> • LEA Y ENTIENDA el Manual de Operador proporcionado, signos de seguridad y calcomanías informativas para el tractor y implemento antes de operar el equipo. • CONTACTE AL DISTRIBUIDOR inmediatamente si no tiene los manuales. • CONTACTE AL DISTRIBUIDOR para que le explique cualquier instrucciones que no entienda completamente. • SIEMPRE USE lentes de seguridad. • USE un casco, zapatos de seguridad y guantes para su protección cuando esta operando el equipo. 			
<p>! DANGER</p>			
			
<p>TO AVOID SERIOUS INJURY OR DEATH:</p> <ul style="list-style-type: none"> • READ AND UNDERSTAND the provided Operator's Manuals, safety signs and information decals for tractor and implement before operating equipment. • CONTACT DEALER immediately if you do not have manuals. • CONTACT DEALER to explain any instructions not fully understood. • ALWAYS WEAR safety glasses. • WEAR hard hat, safety shoes and gloves for protection when operating equipment. 			

D687 SP 5

SEGURIDAD





SEGURIDAD





				
<p>Riesgo de Aplastamiento - Lesion o Muerte</p> <p>PELIGRO</p>		<p>Crushing Hazard - Injury or Death</p> <p>DANGER</p>		
<p>PARA EVITAR LESION SERIA O MUERTE:</p> <ul style="list-style-type: none"> • USE un tractor equipado con Estructura Protectora Contra Vuélicos ("ROPS") incluyendo barra antivuelco y cinturón de seguridad. Mantenga la barra antivuelco en la posición elevada. • PERMANEZCA ALEJADO al quitar el seguro de transporte, y al bajar o subir las alas. • DESPEJE EL ÁREA de personas presentes antes de bajar las alas del implemento. • EL IMPLEMENTO SE PUEDE CAER por el mal funcionamiento hidráulico o operación accidental de los controles. • BLOQUEE y soporte con seguridad el equipo antes de poner manos, pies o cuerpo debajo del equipo o componentes levantados. 		<p>TO AVOID SERIOUS INJURY OR DEATH:</p> <p>D687 SP 4</p> <ul style="list-style-type: none"> • USE tractor equipped with Rollover Protective Structure ("ROPS") including roll bar and seat belt. Keep roll bar in raised position. • STAND CLEAR when removing transport latch, lowering or raising wings. • CLEAR AREA of bystanders before lowering implement wings. • IMPLEMENT CAN FALL from hydraulic failure or accidental operation of controls. • BLOCK UP and securely support equipment before putting hands, feet or body under raised equipment or lifted components. 		

SEGURIDAD

SEGURIDAD

	<p>PELIGRO</p> <p>RIESGO DE ENREDAMIENTO</p>
	<p>PARA EVITAR LESION SERIA O MUERTE:</p> <ul style="list-style-type: none"> • NO opere sin la cubierta protectora en su lugar y en buen estado. Toma De Fuerza (Barra Gritatoria) y guardias de caja de engranaje son SUJETO AL ESGASTE. • MANTENGASE ALEJADO y MANTENGA manos, pies y cuerpo LEJOS de las cuchillas girando, líneas de conducción, y partes que siguen moviéndose después de que el poder es apagado. ESPERE hasta que todos los elementos móviles se han parado. • SIEMPRE REEMPLACE CUBIERTAS que han sido quitadas para servicio o mantenimiento. • DETENGASE, OBSERVE y ESCUCHE por el movimiento de rotación antes de acercarse al implemento. • NO PISE EN las líneas de conducción o cubiertas.
	<p>DANGER</p> <p>ENTANGLEMENT HAZARD</p>
	<p>TO AVOID SERIOUS INJURY OR DEATH:</p> <ul style="list-style-type: none"> • DO NOT operate without guards in place and in good condition. PTO and gearbox guarding are SUBJECT TO WEAR. • STAY AWAY and KEEP hands, feet and body AWAY from rotating blades, drivelines and parts that continue to move after power shut-off. WAIT until all moving elements have stopped. • ALWAYS REPLACE GUARDS that have been removed for service or maintenance. • STOP, LOOK and LISTEN for rotating motion before approaching implement. • DO NOT STEP ON drivelines or guards.
	<p>D687 SP 3</p>

PELIGRO			
			
Riesgo de Atrapeo Lesión o Muerte			
<p>PARA EVITAR LESION SERIA O MUERTE:</p> <ul style="list-style-type: none"> • SIEMPRE ABROCHE el cinturón de seguridad. • SOLO ENCIENDA el tractor mientras que esta sentado en el asiento del operador. • PARE EL MOTOR Y Toma De Fuerza (Barro Gitaño), aplique el freno de mano, baje el implemento, y deje que todas las partes movili paren completamente, y quite la llave antes de desmontar el tractor. • ENTIENDA COMO parar el tractor y equipo rapidamente en caso de una emergencia. • NO MONTE o DESMONTE el tractor en movimiento. • NUNCA PERMITA pasajeros en el tractor o implemento. • NUNCA PERMITA que niños operen o se monten en el tractor o implemento. • MANTENGA LAS PERSONAS PRESENTES LEJOS de la area antes de mover el tractor o implemento. • MANTENGASE ALERTO y EVITE golpes en troncos, agujeros, pozos o terreno en desnivel. • EVITE las ramas de árbol, maleza y algun otros objetos que sobresalen que puedan golpear y tumbar el operador del asiento. 			
DANGER			
Run Over Hazard - Injury or Death			
<p>TO AVOID SERIOUS INJURY OR DEATH:</p> <ul style="list-style-type: none"> • ALWAYS BUCKLE UP seat belt. • ONLY START Tractor while seated in the operator's seat. • STOP ENGINE and PTO, engage parking brake, lower implement, allow all moving parts to stop and remove key before dismounting from tractor. • KNOW HOW to stop tractor and equipment quickly for an emergency. • DO NOT MOUNT or DISMOUNT Tractor in motion. • NEVER ALLOW riders on tractor or implement. • NEVER ALLOW children to operate or ride on tractor or implement. • KEEP BYSTANDERS CLEAR of area before moving tractor or implement. • KEEP ALERT and AVOID hitting stumps, holes, ruts, and uneven terrain. • AVOID tree limbs, brush and other overhanging objects that can strike and throw the operator from seat. 			

 PELIGRO		
		
RIESGO DE OBJETOS LANZADOS		
<p> Cortacésped puede lanzar objetos hasta 300 pies. PARA EVITAR LESION SERIA O MUERTE a operadores y personas presentes: • Pare de segar si personas o tráfico se acercan entre 300 pies del área de segar. • NO OPERE sin la cubierta para objetos lanzados. • MANTENGA la cubierta para objeto lanzado en su lugar y en buenas condiciones. Los protectores de objetos lanzados son sujetos al desgaste. • REPARAR O REEMPLAZAR cubiertas si son dañadas, quebradas, o si faltan. • INSPECCIONE el área por si hay riesgos potenciales de objetos lanzados antes de segar. • REMUEVA y EVITE objetos como alambre, cable, objetos de metal y todo otro material extraño. • NO DEJE que las cuchillas contacten los objetos sólidos como alambre, rocas, postes, borde de banqueta, o barandillas. • NO OPERE en posición de transporte o con las alas levantadas. </p>		
 DANGER		
THROWN OBJECTS HAZARD		
<p> Mower can throw objects up to 300 feet. TO AVOID SERIOUS INJURY OR DEATH to operator or bystanders: • STOP mowing if pedestrians or bystanders come within 300 feet. • DO NOT OPERATE with thrown object shielding removed. • KEEP thrown object shielding in place and in good condition during operation. Thrown Objects shielding is subject to wear. • REPAIR OR REPLACE shielding if damaged, broken or missing. See Operator's Manual for all Shields and Guards. • INSPECT area for potential mower thrown object hazards before mowing. • Remove and AVOID objects such as wire, cable, metal objects and all other foreign material. • DO NOT ALLOW blades to contact solid objects like wire, rocks, posts, curbs or guard rails. • DO NOT OPERATE in transport position or with wings off ground. </p>		
D687 SP 1		

SEGURIDAD

SEGURIDAD

<p>▲ ADVERTENCIA</p>	<p>▲ WARNING</p>	
<p>PARA EVITAR LESION SERIA O MUERTE POR LA PENETRACION A LA PIEL POR ALTA PRESION DE ACEITE HIDRAULICO:</p> <ul style="list-style-type: none"> • NO OPERE el equipo con fugas de aceite o combustible. • MANTENGA todas las mangueras hidráulicas, líneas y conexiones en buenas condiciones y apretadas antes de aplicar presión al sistema. • Releve la presión hidráulica antes de desconectar las líneas o trabajar en le sistema. • QUITE y reemplace la manguera si sospecha que hay fuga. <p>FUGAS DE ALTA PRESION PUEDEN SER INVISIBLE. AL VERIFICAR POR FUGAS HIDRAULICAS Y TRABAJANDO ALREDEDOR DE SISTEMAS HIDRAULICOS:</p> <ul style="list-style-type: none"> • NO use las manos para verificar si hay agujeros. • SIEMPRE USE lentes de seguridad y guantes impermeables. • USE papel o un cartón para buscar agujeros. • NO USE las manos o partes del cuerpo para buscar agujeros. • MANTENGA manos y cuerpo LEJOS de agujeros de alfiler y boquillas que expulsan el líquido hidráulicos. D617 SP 		<p>TO AVOID SERIOUS INJURY OR DEATH FROM HIGH PRESSURE HYDRAULIC OIL LEAKS PENETRATING SKIN:</p> <ul style="list-style-type: none"> • DO NOT OPERATE equipment with oil or fuel leaks. • KEEP all hydraulic hoses, lines and connections in good condition and tight before applying system pressure. • Relieve hydraulic pressure before disconnecting lines or working on the system. • REMOVE and replace hose if you suspect it leaks. Have dealer test it for leaks. <p>HIGH PRESSURE FLUID LEAKS CAN BE INVISIBLE. WHEN CHECKING FOR HYDRAULIC LEAKS AND WORKING AROUND HYDRAULIC SYSTEMS:</p> <ul style="list-style-type: none"> • DO NOT use hands to check for leaks. • ALWAYS WEAR safety glasses and impermeable gloves. • USE paper or cardboard to search for leaks. • KEEP hands and body AWAY from pin holes and nozzles ejecting hydraulic fluid. • Hydraulic fluid may cause gangrene if not surgically removed immediately by a doctor familiar with this form of injury.

SEGURIDAD

Descripción de Calcomanía

▲ ADVERTENCIA		<p>▲ ADVERTENCIA</p> <p>PINCH POINT HAZARD</p> <p>TO AVOID SERIOUS INJURY: ● DO NOT OPERATE with Belt Shield removed.</p>
<p>RIESGO DE PUNTOS DE PELLIZCO</p> <p>PARA EVITAR LESION SERIA: ● NO OPERE con la cubierta de correa ausente. D641 SP</p>		

▲ ADVERTENCIA		<p>▲ WARNING</p> <p>PRESSURIZED TANK</p> <p>OIL FILLER CAP IS PRESSURE RELIEF CAP</p> <p>TO AVOID SERIOUS INJURY AND DEATH FROM HOT OIL: ● STAY AWAY from hot oil that may spray out of tank. ● ALLOW oil to cool down BEFORE removing cap. ● SLOWLY remove cap to relieve pressure BEFORE removing completely.</p>
<p>TANQUE PRESURIZADO</p> <p>LA TAPA DE DEPOSITO DE PETROLEO ES LA TAPA DE ALIVIO DE PRESION.</p>		
<p>▲ ADVERTENCIA</p> <p>PARA EVITAR LESION SERIA O MUERTE POR ESCALDADURA DE PETROLEO CALIENTE: ● MATENGASE ALEJADO del aceite caliente que puede salir a presión del tanque. ● Remueva LENTAMENTE la tapa para relajar la presión ANTES de remover la tapa completamente. ● PERMITA que el petróleo se enfríe ANTES de remover la tapa.</p>		

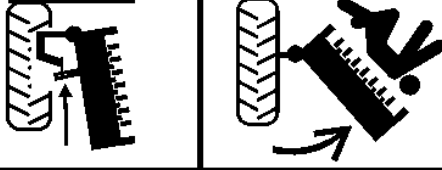
▲ DANGER		<p>Crushing Hazard</p> <p>Transport Latch</p> <p>RAISE AND SECURELY position Wing onto roadways or working under wing.</p>
<p>Riesgo de Aplastamiento</p>		
<p>▲ PELIGRO</p>		
<p>Riesgo de Aplastamiento</p>		
<p>Cierre de Transporte</p> <p>LEVANTE Y DE FORMA SEGURA COLOQUE la ala sobre el cierre de transporte antes de transportar la cortadora en la carretera o trabajando debajo de la ala.</p> <p>D697</p>		

SEGURIDAD

INFORMACIÓN DE PARTES

INFORMACIÓN DE PARTES

Cortacéspedes de ALAMO INDUSTRIAL usan balanceado y componentes del sistema de igualdad para los portadores de la lámina, las láminas, los cortador-ejes, los cuchillos, las suspensiones del cuchillo, los rodillos, los componentes del engranajes de conducción y los cojinetes. Estas piezas se hacen y se prueban a las especificaciones de ALAMO INDUSTRIAL. Partes de No-genuino "cabrer" piezas no resuelven constantemente estas especificaciones. El uso de "cabrer" piezas puede reducir el funcionamiento del cortacéspedes, garantias vacías del cortacéspedes y presentar un peligro de seguridad. ¡Utilice las piezas genuinas de cortacéspedes del ALAMO INDUSTRIAL para la economía y la seguridad! (SPAM-1 SP)

VEA A SU VENDEDOR ALAMO INDUSTRIAL

Manuales de Partes y Operador



www.alqqr.com/aps

NOTA: Si necesita un manual completamente en español por favor de ponerse en contacto a: *Translations, direccion 1502 E. Walnut Street Seguin, TX 78155; Fax: (830) 372-9529*

INTERSTATER 10/18

Sección de Seguridad 1-15

© 2018 Alamo Group Inc.

SEGURIDAD

SEGURIDAD

RIESGOS CON EL MANTENIMIENTO DEL IMPLEMENTO

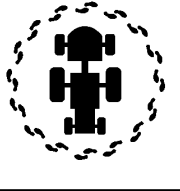
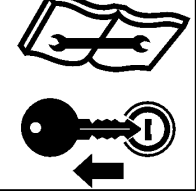
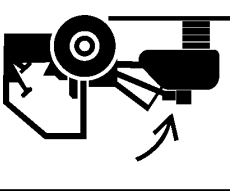
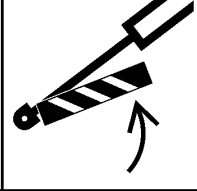
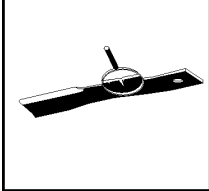
	Inspeccione periódicamente todas las partes móviles, lubrique las líneas de conducción y ajuste todas las sujeciones.
	Apague el motor. Quite la llave antes de realizar tareas de
	Bloquee el implemento antes de repararlo. Utilice bloques grandes sobre suelo blando o húmedo
	Coloque las trabas de transporte cilíndricas
	Inspeccione las cuchillas para detectar daños o fisuras

MANTENGA LOS IMPLEMENTOS EN BUENAS CONDICIONES DE FUNCIONAMIENTO, A TRAVÉS DE UN SERVICIO, REPARACIÓN O MANTENIMIENTO APROPIADO.



ANTES DE REALIZAR TAREAS DE SERVICIO, REPARACIÓN Y MANTENIMIENTO DEL IMPLEMENTO:

- **APAGUE EL MOTOR Y EL PTO**, coloque el freno de mano, descienda el implemento, espere a que se detengan todas las partes móviles y quite la llave antes de bajarse del tractor.
- **COLOQUE** el implemento sobre el suelo o trabe de manera segura los equipos elevados. Utilice bloques grandes sobre suelo blando o húmedo.
- **EMPUJE Y JALE** la palanca del Cilindro Hidráulico Remoto para liberar la presión hidráulica.
- **DESCONECTE** la línea de conducción del **IMPLEMENTO DEL EJE DE PTO** del tractor.

USE GAFAS DE SEGURIDAD Y GUANTES PROTECTORES Y SIGA TODOS LOS PROCEDIMIENTOS DE SEGURIDAD al realizar

- **tareas de servicio, reparación y mantenimiento sobre el implemento:**
- Siempre **USE GUANTES** y **GAFAS DE SEGURIDAD** al reparar componentes en caliente
- **EVITE EL CONTACTO** con tanques de aceite hidráulico, bombas, motores, válvulas y superficies de conexión de mangueras calientes.

SUJETE FIRMEMENTE o TRABE EN POSICIÓN ELEVADA todos los implementos, bastidores y componentes elevados antes de

- trabajar sobre los equipos que se encuentran debajo.
- **DETENGA** el movimiento de todos los implementos y **APAGUE EL MOTOR DEL TRACTOR** antes de realizar ninguna tarea.
- **USE** una escalera o gradas elevadas para alcanzar áreas altas del equipo a las que no se pueda acceder desde la tierra.
- **ASEGURESE** de estar bien apoyado sobre superficies sólidas planas al subirse al implemento para realizar tareas.
- **SIGA** las instrucciones sobre cómo manipular los lubricantes, solventes, limpiadores y otros agentes químicos.
- **NO** cambie ninguna calibración hidráulica de fábrica para evitar fallas de los componentes o equipos.
- **NO** modifique o altere el implemento, las funciones o componentes.
- **NO** suelde o repare los componentes de la cortadora. Esto puede causar vibraciones y fallas de los componentes que se desprendan de la cortadora.

REALICE LAS TAREAS DE SERVICIO, REPARACIÓN, LUBRICACIÓN Y MANTENIMIENTO QUE SE DESCRIBEN EN LA SECCION DE MANTENIMIENTO DEL IMPLEMENTO:





- **INSPECCION** el implemento para detectar sujeciones sueltas, partes gastadas o rotas, ajustes sueltos o con filtraciones, que los pasadores tengan chavetas y arandelas, y las partes móviles para detectar el desgaste.
- **REEMPLACE** todas las partes gastadas o rotas con repuestos autorizados.
- **LUBRIQUE** la unidad tal como se especifica en el cronograma de lubricación.
- **NUNCA** lubrique, ajuste o quite material mientras el equipo está en funcionamiento o movimiento.
- **AJUSTE** todas las tuercas y pernos tal como se especifica.
- **INSPECCION DE CUCHILLAS:**
- **REEMPLACE** las cuchillas dobladas, dañadas, agrietadas o rotas inmediatamente por cuchillas nuevas.
- **EVITE** fallas de las cuchillas y que vuelen trozos de cuchillas. **NO** enderece, suelde o suelde con superficies rígidas.
- **INSPECCION DE PROTECTORES DE SEGURIDAD, GUARDAS Y DISPOSITIVOS DE SEGURIDAD:**
- **MANTENGA** en su lugar y en buen estado todos los defletores, protectores de acero, cubiertas de caja de engranajes, cubiertas integrales de PTO, bandas, falldones laterales y capatas antideslizantes.
- **REEMPLACE** cualquier protector, cubierta o dispositivo de seguridad fallante, roto o gastado.
- **DESCONECTE** la válvula de solenoide de la bomba o la conexión de la línea de conducción de la TDF de antes de reparar el cabezal de la cortadora.
- **SIGA LAS INSTRUCCIONES** de la sección de mantenimiento al reemplazar los cilindros hidráulicos para evitar la caída de componentes

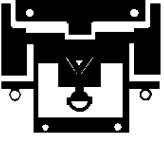

Operar, dar servicio y mantener este equipo puede exponerlo a productos químicos como gasolina, combustible diesel, lubricantes, productos derivados del petróleo, gases de escape de motores, monóxido de carbono y flúatos, que el Estado de California considera que causan cáncer y otros daños relacionados con el nacimiento y crecimiento. Para minimizar la exposición, evite respirar el escape, no haga funcionar el motor en ralentí excepto cuando sea necesario, haga el mantenimiento de su vehículo en un área bien ventilada y use guantes o lávese las manos frecuentemente cuando realice el mantenimiento de su vehículo. Los postes de la batería, terminales y accesorios relacionados contienen plomo y compuestos de plomo, productos químicos que en el estado de California son conocidos por causar cáncer, defectos de nacimiento y otros daños reproductivos. Para obtener más información, vaya a www.P65Warnings.ca.gov. Este sitio web, operado por la Oficina de Evaluación de Peligros para la Salud Ambiental de California, proporciona información sobre estos químicos y cómo las personas pueden estar expuestas a ellos. **PN HM02 SP**

SEGURIDAD

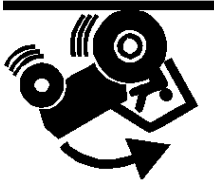
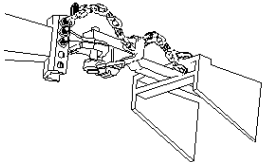
RIESGOS EN TRANSPORTE

 <p>Use señales de SMV (vehículo de movimiento lento) y balizas</p>	 <p>Peligro de detención por pérdida de control</p>	 <p>Peligro de velocidad excesiva por pérdida de control</p>	 <p>Use la cadena de remolque de seguridad – Tractor a implemento</p>	 <p>Coloque las trabas de transporte</p>
----------------------------------------------------------------------------------------------------------------------------------------------------------	-----------------------------------------------------------------------------------------------------------------------------------------	-------------------------------------------------------------------------------------------------------------------------------------------------	----------------------------------------------------------------------------------------------------------------------------------------------------------	-----------------------------------------------------------------------------------------------------------------------------



PARA EVITAR LESIONES GRAVES O LA MUERTE AL REMOLCAR O TRANSPORTAR EQUIPOS:

- **MANTENGA** la velocidad de transporte **POR DEBAJO DE 20** millas por hora para mantener el control del equipo.
- **REDUZCA LA VELOCIDAD** en terreno inclinado, en las curvas y en condiciones de remolque desfavorables.
- **NO REMOLQUE** camiones u otros vehículos
- **USE** un tractor de tamaño adecuado y equipado en función del equipo de remolque.
- **SIGA** todas las reglamentaciones de tránsito locales.
- **REQUISITOS DEL TRACTOR PARA REMOLCAR O TRANSPORTAR IMPLEMENTOS:**
- **SOLO TRANSPORTE** en el tractor con el mecanismo **ROPS** (antivuelco) en posición elevada.
- **USE** un tractor de tamaño adecuado y equipado, que supere el peso del implemento en al menos un 20%
- **MANTENGA EL 20%** del peso del tractor en las ruedas frontales para mantener la dirección en forma segura.

ANTES DE TRANSPORTAR O REMOLCAR EL IMPLEMENTO:

- **INSPECCIÓN DEL TRACTOR:**
- **VERIFIQUE** la dirección y los frenos para asegurarse el correcto funcionamiento y las condiciones adecuadas.
- **VERIFIQUE LLEVAR EL AVISO DE SMV**, los reflectores y las luces de advertencia para la adecuada operación y visibilidad detrás de la unidad.
- **VERIFIQUE** que no haya impedimentos a la visión mientras conduce, en el tractor, la cabina o el implemento, sentado en el asiento del tractor.
- **AJUSTE** su posición de conducción, los espejos y el transporte del implemento para tener una visión clara para condiciones de conducción y tránsito.

PREPARE EL IMPLEMENTO PARA EL TRANSPORTE O EL REMOLQUE:

- **COLOQUE LAS TRABAS PARA TRANSPORTE Y LAS CADENAS DE SEGURIDAD:**
- **ELEVE LA CORTADORA e INSTALE** topes o pasadores de transporte cilíndricos en el eje central
- **ELEVE LAS ALAS e INSTALE TRABAS DE TRANSPORTE** o pasadores.
- **AJUSTE LA CADENA DE SEGURIDAD** del implemento al tractor.
- **QUITTE** todo material cortado que se acumule en la plataforma de la cortadora.
- **DETERMINAR LAS CARACTERÍSTICAS DE DETENCIÓN DEL TRACTOR Y EL IMPLEMENTO PARA EL TRANSPORTE O REMOLQUE:**

PRUEBAS DE FRENADO:

- **FRENE** a velocidades en aumento.
- **DETERMINE** las distancias de **DETECCIÓN** con el aumento de velocidad.
- **DETERMINE** la velocidad de transporte máxima segura que no supere las 20 millas por hora.
- **DETERMINE LA VELOCIDAD DE GIRO MÁXIMA ANTES DE OPERAR EN CARRETERAS O TERRENO IRREGULAR:**

- **PONGA A PRUEBA** el equipo aumentando lentamente la velocidad en las curvas para determinar si se puede operar a mayor velocidad.
- **USE MENORES** velocidades de giro en las curvas pronunciadas para evitar el vuelco.
- **AL REMOLCAR O TRANSPORTAR EL EQUIPO:**
- Siempre **USE EL CINTURÓN DE SEGURIDAD** al operar o transportar la cortadora.
- **USE** bajas velocidades para evitar el vuelco con las alas elevadas.
- **USE** bajas velocidades y dirección gradual en las curvas, colinas, o en superficies irregulares o poco uniformes, y en carreteras mojadas.
- **ENCIENDA LAS BALIZAS DE ADVERTENCIA** del tractor.
- **TENGA EN CUENTA** el espacio necesario para el vaivén del implemento en las curvas.
- **MANTENGA** todas las alas elevadas a 3 metros (10 pies) o una mayor distancia de todos los cables de alimentación y obstrucciones elevadas. *PN TH01 SP*

SEGURIDAD

RIESGOS ELÉCTRICOS Y DE FUEGO

<p>Contacto de ala con cables eléctricos elevados</p>	<p>Riesgo de choque y explosión Contacto de paletas con líneas de servicios o gas</p>	<p>No opere cerca de fuego. Mantenga limpia la plataforma de la cortadora</p>
		

▲ PELIGRO PARA EVITAR LESIONES GRAVES O LA MUERTE POR CONTACTO ELÉCTRICO AL TRABAJAR CERCA DE CABLES ELÉCTRICOS, LÍNEAS DE GAS Y DE SERVICIOS:

- **INSPECCIONE** el área de corte para que no interfiera con cables de alimentación eléctricos subterráneos, obstrucciones, líneas de gas, cables y servicios, estructuras municipales o de otro tipo.
- **MANTENGA** todas las alas elevadas a 3 metros (10 pies) o una mayor distancia de todos los cables de alimentación y obstrucciones elevadas.
- **NO** ponga en contacto la cortadora con ninguna estructura u obstrucción de servicios o municipales.
- **LLAME** AL 811 y al 1-800-258-0808 para identificar cables de servicios subterráneos.

PAUTAS DE PREVENCIÓN DE INCENDIOS durante la operación, reparación, servicio de la cortadora y el tractor, a fin de reducir el riesgo de incendio del equipo y de la vegetación:

- El tractor debe estar **EQUIPADO CON MATAFUEGOS**
- **NO OPERE** la cortadora sobre un tractor equipado con escape debajo del bastidor
- **NO FUME** ni acerque fuego directo a la cortadora o el tractor
- **NO CONDUZCA** sobre residuos encendidos o en áreas recientemente quemadas
- **EVITE LA FORMACIÓN DE CHISPAS** al no permitir que la hoja de la cortadora entre en contacto con objetos sólidos como metal o roca.
- **AJUSTE LOS EMBRAGUES DESLIZANTES** para evitar el deslizamiento excesivo y el calentamiento de la placa del embrague
- **LIMPIE** todo resto de hierba o residuo acumulado alrededor de las líneas de conducción de la cortadora, los embragues deslizantes y cajas de cambios.
- **APAGUE EL MOTOR** al cargar combustible.
- **NO OPERE** el equipo con filtraciones de aceite o combustible. Repare cualquier filtración de aceite y retire el aceite acumulado antes de operar.
- **LIMPIE** todo resto de hierba o residuo acumulado alrededor de las bombas hidráulicas, valvulas, o tanques hidráulicos. *PN EFM-01 SP*

SEGURIDAD

SEGURIDAD

RIESGO DE FILTRACION DE ACEITE HIDRÁULICO DE ALTA PRESIÓN

 <p>Penetración de aceite de alta presión en la piel</p>	 <p>Erosión de la piel por el aceite de alta presión</p>	 <p>Usar cartón para detectar filtraciones de aceite</p>	 <p>Los contenidos del tanque están bajo presión. Permita que el aceite se enfríe antes de quitar la tapa.</p>
-----------------------------------------------------------------------------------------------------------------------------------------------	----------------------------------------------------------------------------------------------------------------------------------------------	---------------------------------------------------------------------------------------------------------------------------------------------	---------------------------------------------------------------------------------------------------------------------------------------------------------------------------------------------------

▲ PELIGRO PARA EVITAR LESIONES GRAVES O LA MUERTE POR PENETRACIÓN DE FILTRACIONES DE ACEITE HIDRÁULICO DE ALTA PRESIÓN:

- **NO OPERE** el equipo con filtraciones de aceite o combustible.
- **MANTENGA** todas las mangueras hidráulicas, líneas y conexiones en **BUEN ESTADO** y **AJUSTADAS** antes de aplicar presión al sistema.
- **LIBERE LA PRESIÓN HIDRÁULICA** antes de desconectar las líneas o trabajar en el sistema.
- **QUITTE** y reemplace la manguera si sospecha que tiene filtraciones. Solicite al distribuidor que verifique si hay filtraciones.

LAS FILTRACIONES DE LÍQUIDO DE ALTA PRESIÓN PUEDEN NO SER VISIBLES.

AL VERIFICAR FILTRACIONES HIDRÁULICAS Y TRABAJAR CERCA DE LOS SISTEMAS HIDRÁULICOS:

- **SIEMPRE USE** gafas de seguridad y guantes impenetrables.
- **USE** papel o cartón para verificar si hay filtraciones.
- **NO USE** las manos o partes del cuerpo para detectar filtraciones.
- **MANTENGA** las manos y el cuerpo **LEJOS** de los orificios de clavijas y boquillas de eyección de fluido hidráulico. El fluido hidráulico puede causar gangrena si no es extraído quirúrgicamente de inmediato por un médico especializado en este tipo de lesiones.

Tenga cuidado cuando retire la tapa del tanque hidráulico.

- Los contenidos del tanque pueden estar bajo presión.
- Siempre permita que el aceite se enfríe antes de quitar la tapa.
- Libere la presión de aceite antes de retirar la tapa lentamente.
- Alejese del aceite caliente que pueda rociarse desde el tanque.

PN HPFM-01_SP

SEGURIDAD

SEGURIDAD

RIESGO DEL CONTACTO A LAS CUCHILLAS DE CORTADORA

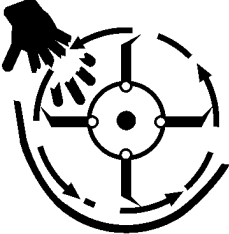
 <p>No ponga los dedos debajo de la cortadora</p>	 <p>No ponga el pie debajo de la cortadora</p>	 <p>Detenga el tractor. Quite la llave. Lea el Manual</p>
----------------------------------------------------------------------------------------------------------------------------------------	-----------------------------------------------------------------------------------------------------------------------------------	----------------------------------------------------------------------------------------------------------------------------------------------

PELIGRO MANTÉNGASE LEJOS DE LAS CUCHILLAS GIRATORIAS PARA EVITAR LESIONES GRAVES O LA MUERTE POR CONTACTO CON LA CUCHILLA:

- MANTÉNGASE LEJOS y NO ACERQUE LAS MANOS, LOS PIES y EL CUERPO a las cuchillas giratorias, líneas de conducción y partes hasta que todos los elementos móviles se hayan detenido.
- NO ponga las manos o los pies debajo de las plataformas de la cortadora
- DETENGA las CUCHILLAS giratorias antes de elevar la plataforma de la cortadora o las alas
- DETENGA la cortadora, EXAMÍNELA y PRESTE ATENCIÓN A LOS SONIDOS antes de acercarse a la cortadora para asegurarse de que se haya detenido todo el movimiento giratorio. *PN MBFM-01 SP*

SEGURIDAD

RIESGO DE ENREDO POR EL PTO

<p>Peligro de enredo No se acerque o toque ningún eje de transmisión de PTO giratorio</p>	
<p>Asegúrese de que el eje de PTO esté firmemente sujetado. No use un adaptador de PTO</p>	<p>PTO (Barra Gítoria)</p> 
<p>No opere la máquina si las cubiertas de PTO están dañadas o faltantes</p>	
<p>Asegúrese de que los ejes de PTO sean del largo adecuado</p>	

▲ PELIGRO MANTÉNGASE ALEJADO DE LAS LÍNEAS DE CONDUCCIÓN Y OTROS ELEMENTOS GIRATORIOS PARA EVITAR LESIONES GRAVES O LA MUERTE:

MANTÉNGASE LEJOS Y NO ACERQUE las manos, los pies y el cuerpo a las cuchillas giratorias, líneas de conducción y partes hasta que todos los elementos móviles se hayan detenido.

- **DETENGA** la cortadora, **EXAMÍNELA Y PRESTE ATENCIÓN A LOS SONIDOS** antes de acercarse a la cortadora para asegurarse de que se haya detenido todo el movimiento giratorio.
- **LOS ELEMENTOS GIRATORIOS SIGUEN ROTANDO** una vez apagada la PTO.

PROTECCIÓN DE LA PTO:

PARA EVITAR LESIONES GRAVES O LA MUERTE POR ENREDO AL OPERAR EL IMPLEMENTO:

- **MANTENGA** instalados los protectores, las cubiertas integrales de las líneas de conducción y las cubiertas de entrada
- **NO OPERE** la cortadora si los protectores o cubiertas no están bien colocados o faltan.
- **REEMPLACE O REPARÉLOS** si faltan, están dañados o rotos
- **SIEMPRE REEMPLACE LOS PROTECTORES** que se han quitado para tareas de reparación o mantenimiento.

PARA EVITAR que la línea de conducción se rompa durante las operaciones:

- **VERIFIQUE** que la línea de conducción tenga el largo adecuado entre el eje de PTO y el eje de la caja de cambios del implemento.
- Las líneas de conducción demasado cortas se pueden soltar o romper.
- Las líneas de conducción demasado largas pueden tocar el suelo.

- Un ensamblaje telescópico de la línea de conducción que toque el suelo no se deslizará y se solidificará.
- Si la línea de conducción toca el suelo, puede atravesar los cojinetes de soporte y romper el eje de PTO.
- **EVITE** hacer curvas pronunciadas o elevar la cortadora a alturas que puedan hacer caer la línea de conducción.
- Lubrique los componentes telescópicos del eje de transmisión en forma semanal.

COMUNÍQUESE CON EL DISTRIBUIDOR si la línea de conducción del implemento no coincide con el eje de PTO del tractor:

- **NO UTILICE UN ADAPTADOR DE PTO.**

El uso de un adaptador de PTO puede causar vibración excesiva, caída de objetos, fallas de las cuchillas y el implemento como consecuencia de la duplicación de la velocidad operativa. El aumento de la longitud de trabajo puede exponer áreas desprotegidas de la línea de conducción. *PN PE01 SP*

SEGURIDAD

RIESGO DE ATROPELLO

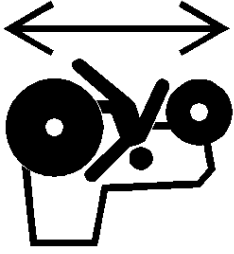
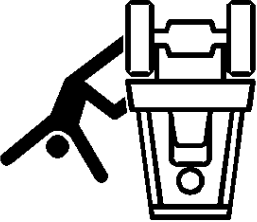
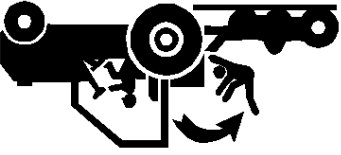
		
<p>Riesgo de atropello del operador</p>	<p>Riesgo de atropello por caída del operador</p>	<p>Riesgo de atropello por caída del operador</p>

▲ PELIGRO PARA EVITAR LESIONES GRAVES O LA MUERTE POR CAÍDA DEL TRACTOR O ATROPELLO DEL EQUIPO:

- USE tractores equipados con SISTEMA ANTIVUELCO (ROPS) y CINTURONES DE SEGURIDAD para las operaciones de corte.
 - MANTENGA EL SISTEMA ROPS trabado en posición vertical.
 - SÓLO ENCIENDA el tractor sentado en el asiento del tractor.
 - SIEMPRE ABROCHESE el cinturón de seguridad al operar el tractor y los equipos.
 - SÓLO OPERE el tractor y el equipo sentado en el asiento del tractor.
 - NUNCA LLEVE A OTRAS PERSONAS en el tractor o implemento.
- AL SUBIR Y BAJAR DEL TRACTOR:**
- SÓLO suba o baje del tractor cuando éste y sus partes móviles estén detenidos.
 - APAGUE EL MOTOR Y LA TDF, coloque el freno de mano, descienda del implemento, espere a que se detengan todas las partes móviles y quite la llave antes de bajarse del tractor. *PN R001 SP*

SEGURIDAD

RIESGO DE OBJETOS LANZADOS (Continuado)

Peligro de objetos lanzados por la cortadora	
Objetos lanzados desde cortadora elevada	
Inspeccione el área. Quite los objetos extraños	
No permita que las cuchillas entren en contacto con objetos sólidos	

OPERACIÓN DE LA CORTADORA:

- **NO** exceda la capacidad de corte nominal de la cortadora, ni corte elementos que no sean vegetación.
- **USE CABINAS DE TRACTOR CERRADAS** cuando haya dos o más cortadoras operando en un mismo sector..
- **AJUSTE** las secciones de la cortadora o la ala cercana y paralela al suelo sin exponer las cuchillas
- **AJUSTE LA ALTURA** de corte para **EVITAR EL CONTACTO DE LAS CUCHILLAS** con objetos sólidos, como alambres, piedras, postes, cordones, guardarrailles y obstrucciones fijas.
- **NO** opere la cortadora con la(s) ala(s) elevada(s) o en posición de transporte.
- **DETENGA LA CORTADORA** de inmediato si las cuchillas entran en contacto con objetos pesados, estructuras fijas, guardarrailles de metal y estructuras de cemento:
- 1. **LAS CUCHILLAS PUEDEN FALAR** con el impacto y los objetos pueden ser arrojados a gran velocidad.
- 2. **INSPECCIONE y REEMPLACE** las cuchillas dañadas.
- 3. **VERIFIQUE** el equilibrio del porta cuchillas y **REEMPLÁCELO** si está dañado.
- **NO** opere la cortadora en agua **PARA EVITAR** una posible **FALLA DE LAS CUCHILLAS**.
- **EVITE OPERAR LA CORTADORA** en reversa:
 1. **DETENGA EL PTO** y retroceda la cortadora.
 2. **DESCIENDA** la cortadora, encienda el **PTO** y corte hacia adelante.
- **DETENGA EL PTO** y las **CUCHILLAS** al elevar la cortadora a posición de transporte.
- **NO** encienda el **PTO** con la cortadora en posición de transporte.
- **DETENGA** la cortadora cuando se produzca **VIBRACIÓN EXCESIVA**:
 1. **DETENGA EL PTO Y EL MOTOR** del tractor.
 2. **INSPECCIONE** la cortadora para detectar la fuente de la vibración
 3. **REEMPLACE** toda parte dañada o las **CUCHILLAS** dobladas o dañadas. *PN TOM-02 SP*

SEGURIDAD

RIESGO DE OBJETOS LANZADOS

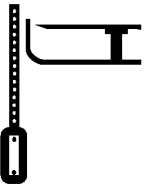
			
Peligro de objetos lanzados por la cortadora	Objetos lanzados desde cortadora elevada	Inspeccione el área. Quite los objetos extraños	No permita que las cuchillas entren en contacto con objetos sólidos



LAS CORTADORAS GIRATORIAS PUEDEN ARROJAR OBJETOS A 90 METROS (300 PIES) O MÁS EN CONDICIONES ADVERSAS.

PARA EVITAR LESIONES GRAVES O LA MUERTE AL OPERADOR O TRANSEÚNTES COMO CONSECUENCIA DE OBJETOS ARROJADOS:

- MANTENGA a los transeúntes a 100 metros de distancia (300 pies)
- **NO OPERE LA CORTADORA SI HAY PERSONAS A MENOS DE 100 METROS(300 PIES), SALVO QUE:**

- Todos los **PROTECTORES CONTRA OBJETOS ARROJADOS** estén colocados y en buen funcionamiento al operar la cortadora, entre los que se incluyen los deflectores frontales y traseros, los protectores de acero, las bandas, los faldones laterales y las zapatas antidestilizantes.

- Las partes de la cortadora o la aia estén ajustadas cerca y paralelas al suelo, sin exponer las cuchillas.
- Se ha inspeccionado el **ÁREA DE CORTE** y se han quitado todos los materiales extraños y residuos.
- **LOS TRANSEÚNTES** estén en el interior de un vehículo cerrado.

ANTES DE OPERAR LA CORTADORA, INSPECCIONE EL ÁREA PARA DETECTAR LA POSIBILIDAD DE OBJETOS QUE PUEDAN SER LANZADOS:

- **QUITE** residuos, piedras, cables, alambres, objetos metálicos y cualquier otro objetos extraños del área.
- Los alambres, cables, sogas, cadenas y objetos metálicos pueden ser arrojados o salir desprendidos de la plataforma a gran velocidad:

No permita que las cuchillas de la cortadora entren en contacto con cadáveres de animales en descomposición o otros materiales peligrosos. Las cuchillas de la cortadora podrían arrojar materiales peligrosos y biológicos de la cortadora, exponiendo al operador y personas presentes a riesgos de salud. Siempre use el equipo de protección personal (PPE) aprobado por OSHA cuando limpie o retire material potencialmente peligroso de equipo.

1. **MARQUE** los objetos que no se puedan quitar.
2. **EVITE** estos objetos cuando use la cortadora.

INSPECCIÓN DEL ÁREA PARA DETECTAR HIERBA ALTA Y MALEZAS:

- **INSPECCIONE Y QUITE** cualquier residuo oculto de gran tamaño.
- **PASE LA CORTADORA** a una altura intermedia
- **INSPECCIONE** y quite el residuo restante
- **PASE LA CORTADORA** a la altura final

PROTECCIÓN CONTRA OBJETOS ARROJADOS DE LA CORTADORA:

- **MANTENGA** todos los protectores contra objetos arrojados en su lugar y en buen funcionamiento al operar la cortadora, entre los que se incluyen los deflectores frontales y traseros, los protectores de acero, las bandas, los faldones laterales y las zapatas antidestilizantes.

- **NO OPERE LA CORTADORA** si falta algún protector contra objetos arrojados, o si éstos están dañados.

DERECHO DE PASO (autopista) CON LA CORTADORA

- Ninguna protección ofrece una eficacia del 100% en la prevención de objetos arrojados. Para reducir la posibilidad de que se produzcan lesiones:

1. **MANTENGA LOS PROTECTORES DE LA CORTADORA**, los faldones laterales, las zapatas antidestilizantes y las cuchillas en buen estado de funcionamiento,
2. **ELEVE LA ALTURA DE CORTE a 15 CM (6 PULGADAS)** como mínimo,
3. **INSPECCIONE EL ÁREA** con cuidado antes de pasar la cortadora para ELIMINAR el posible riesgo de **OBJETOS ARROJADOS**,
4. **NUNCA PERMITA QUE LAS CUCHILLAS EN MOVIMIENTO ENTREN EN CONTACTO CON OBJETOS SÓLIDOS** como

alambres, piedras, postes, cordones, guardarrallies o el suelo. **PN T0FM-01 SP**

SEGURIDAD

SEGURIDAD DE CONECTAR O DESCONECTAR IMPLEMENTO

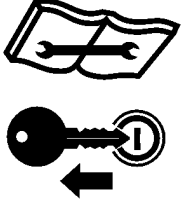
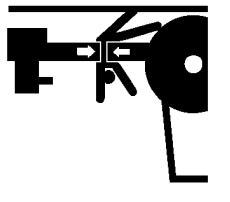
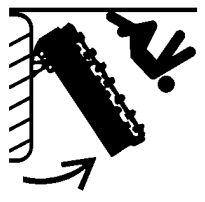
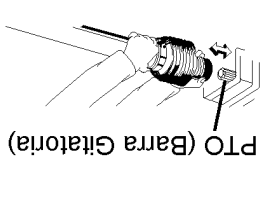
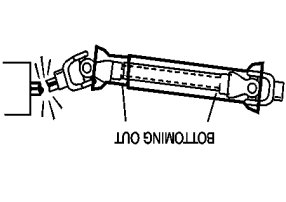
 <p>Detenga el tractor e Quite la llave Lea el Manual</p>	 <p>Lesión opresiva entre tractor e implemento</p>	 <p>Lesión aplastante por caída de ala</p>	 <p>PTO (Barra Gítoria)</p> <p>Asegúrese de que el eje de TDF esté firmemente ajustado al tractor</p>	 <p>Asegúrese de que el eje de TDF sea del largo adecuado</p>
------------------------------------------------------------------------------------------------------------------------------------------------	----------------------------------------------------------------------------------------------------------------------------------------	-------------------------------------------------------------------------------------------------------------------------------	------------------------------------------------------------------------------------------------------------------------------------------------------------------------------------------	--------------------------------------------------------------------------------------------------------------------------------------------------

▲ PELIGRO

PARA EVITAR LESIONES GRAVES O LA MUERTE POR APLASTAMIENTO POR EL TRACTOR O IMPLEMENTO:

AL DAR MARCHA ATRÁS el tractor hacia el enganche del implemento:

- **NO PERMITA QUE HAYA PERSONAS** entre el tractor y el implemento

ANTES de conectar y desconectar el enganche del implemento:

- **APAGUE EL MOTOR DEL TRACTOR**, coloque la palanca en "estacionar", ponga el freno de mano y saque la llave.

Al conectar y desconectar el enganche del implemento:

- **NO** se agache o camine debajo de la cortadora o la ala en posición elevada.

AL CONECTAR LA LÍNEA DE CONDUCCIÓN DEL IMPLEMENTO:

PARA EVITAR que la línea de conducción del implemento se suelte durante la operación:

- **LUBRIQUE** el anillo de cierre del resorte del yugo para asegurarse de que se deslice libremente sobre el eje de **PTO**
- **ASEGURE** las bolas de cierre del yugo en la muesca del eje de **PTO**.

- **PRESIONE y JALE DE LA LÍNEA DE CONDUCCIÓN del EJE DE TOMA DE FUERZA(PTO)** del tractor y del implemento para asegurarse de que estén **FIRMEMENTE SUJETADOS**

PARA EVITAR que la línea de conducción se rompa durante las operaciones:

- **VERIFIQUE** que la línea de conducción tenga el largo adecuado entre el eje de **PTO** y el eje de la caja de cambios del implemento.
- Las líneas de conducción demastado cortas se pueden soltar o romper.
- Las líneas de conducción demastado largas pueden tocar el suelo.
- Un ensamblaje telescópico de la línea de conducción que toque el suelo no se deslizará y se solidificará.
- Si la línea de conducción toca el suelo, puede atravesar los cojinetes de soporte y romper el eje de **PTO**.

COMUNIQUESE CON EL DISTRIBUIDOR si la línea de conducción del implemento no coincide con el eje de TDF del tractor:

- **NO UTILICE UN ADAPTADOR DE PTO.**
- El uso de un adaptador de **PTO** puede ocasionar:
- Vibración excesiva, caída de objetos, fallas de la hoja y el implemento como consecuencia de la duplicación de la velocidad opera-
- tiva.
- Mayor extensión de trabajo, lo que deja expuestas áreas desprotegidas de la línea de conducción e implica el riesgo de entredo con otros objetos.

ANTES DE QUITAR LAS TRABAS DE RETENCIÓN DE LAS ALAS:

- **LLENE** los cilindros de las alas con lubricante
- **MANTENGA** a los transeñetes lejos del área antes de operar las alas
- **DESCIENDA LAS ALAS** de manera lenta y cuidadosa.

NO conecte la cortadora a un tractor con la TDF directamente conectada a la transmisión del tractor. PN CDFM-03 SP

SEGURIDAD

RIESGO DE APLASTAMIENTO

				
Lesión aplastante por caída de ala	Lesión aplastante por caída de implemento	Siempre utilice cinturón de seguridad	Trabe el sistema ROPS (antivuelco) en la posición vertical	Lesión aplastante por vuelco

PELIGRO PARA EVITAR UNA LESIÓN GRAVE O LA MUERTE POR CAÍDA DEL TRACTOR, O EL APLASTAMIENTO, VUELCO Y APLASTAMIENTO DE UN EQUIPO POR LA CAÍDA DE UNA ALA O UN IMPLEMENTO:

- USE tractores equipados con **SISTEMA ANTIVUELCO (ROPS) Y CINTURONES DE SEGURIDAD** para las operaciones de corte.
- **MANTENGA EL SISTEMA ROPS** trabado en posición vertical.
- **SIEMPRE ABROCHÉSE** el cinturón de seguridad al operar el tractor y los equipos.
- **SOLO OPERE** el tractor y el equipo sentado en el asiento del tractor.
- **EN CASO DE EMERGENCIA**, apague el motor del tractor, desenganche la toma de fuerza y espere a que todo movimiento de rotación se detenga. Coloque el tractor en posición de estacionamiento, ponga el freno de estacionamiento y retire la llave antes de abandonar el asiento del operador.

AL ELEVAR O DESCENDER LAS ALAS:

- Eleve o descienda las alas **SÓLO CUANDO ESTÉ SENTADO** en el asiento del tractor, con el cinturón de seguridad ajustado.
- **PARA EVITAR** el vuelco del implemento.
- **MANTENGA A LOS TRANSEUNTES FUERA** del área de operación **PARA EVITAR** accidentes por aplastamiento.
- **MANTENGA** suficiente espacio libre alrededor de los implementos y alas **PARA EVITAR** el contacto con edificios o cables elevados.

Los equipos **ELEVADOS** se pueden caer por fallas mecánicas o hidráulicas o por un movimiento inesperado de la palanca de control.

ADVERTENCIA

PARA EVITAR LA CAÍDA DEL EQUIPO al trabajar cerca o debajo de las alas, los componentes e implementos elevados por un enganche de tractor de 3 puntos:

- **SUJETE CON FIRMEZA** o bloquee en posición vertical todos los equipos, alas y componentes elevados.
- **BLOQUEE EN POSICIÓN VERTICAL** y sujete con firmeza el equipo antes de poner las manos, los pies o el cuerpo debajo de los equipos o componentes elevados.
- **MANTENGA A LOS TRANSEUNTES LEJOS** de las alas dobladas hasta que estén bloqueadas o trabadas en posición vertical.

AL ESTACIONAR el implemento y el tractor:

- **DESCIENDA** el implemento, **TRABE** o **BLOQUEE** las partes elevadas antes de alejarse del equipo.
- **NUNCA** deje un implemento sin atención en posición elevada.

ADVERTENCIA

PARA EVITAR LA CAÍDA O EL APLASTAMIENTO DE NIÑOS POR EL EQUIPO:

- **NUNCA DEJE** que los niños jueguen sobre el tractor o los implementos, ni en sus alrededores.
- **AL DESENGANCHAR EL IMPLEMENTO:**





- **DESCIENDA** el implemento, **TRABE** o **BLOQUEE** las partes elevadas antes de alejarse del equipo.
- **USE** el gato de la lengüeta para controlar el movimiento de la lengüeta del implemento.
- **USE** el **GATO** de la lengüeta para elevar lengüetas de implementos pesados.
- **EVITE** recargar el gato para evitar falla al gato y una lesión al operador.

ANTES DE QUITAR LAS TRABAS DE RETENCIÓN DE LAS ALAS:

- **CONECTE** las mangueras al tractor.
- **LENE** los cilindros de las alas con lubricante
- **MANTENGA** a los transeuntes lejos del área de funcionamiento de las alas
- **DESCIENDA LAS ALAS** de manera lenta y cuidadosa. *PN CH01 SP*

SEGURIDAD

SEGURIDAD DEL OPERADOR

	Lea con atención el Manual del Operador
	Siempre use gafas de seguridad
	Use casco y calzado protector
	Nunca consuma drogas o alcohol mientras opera el equipo
	Utilice chaleco de seguridad al operar en o cercas de carreteras

PARA EVITAR LESIONES GRAVES O LA MUERTE, SIGA LAS SIGUIENTES INSTRUCCIONES:



- **LEA, COMPRENDA y SIGA** las instrucciones del Manual del Operador, al igual que las Advertencias y Mensajes de Seguridad.
- **USE GAFAS DE SEGURIDAD**, calzado protector, casco, protección auditiva y guantes al operar o reparar el equipo.
- **USE** un aparato de respiración apropiado al operar en condiciones polvorientas a fin de evitar contraer enfermedades respiratorias.
- **NO USE** prendas sueltas o joyas que se puedan enredar con las partes giratorias y causar una lesión.
- **NO CONSUMA DROGAS o ALCOHOL** antes o durante la operación del equipo.
- **NO PERMITA** que nadie opere el equipo bajo los efectos negativos de las drogas o el alcohol.
- **CONSULTE** a un médico para conocer los efectos desfavorables de la medicación sobre los sentidos.
- **MANTÉNGASE ALERTA**, la operación prolongada puede causar fatiga. **HAGA UNA PAUSA y DESCANSE.**

SEGURIDAD DE OPERACIÓN GENERAL

- **CONDICIONES DE VISIBILIDAD AL USAR LA CORTADORA:**
- **OPERE LA CORTADORA CON LUZ SOLAR** o con luz que aporte una visibilidad nítida de más de 90 metros (100 yardas).
- **DEBE PODER VISUALIZAR e** identificar transeúntes, terrenos empinados, pozos, desniveles, obstrucciones elevadas, cables de alimentación, residuos y objetos extraños.
- **VELOCIDAD RESPECTO AL SUELO AL USAR LA CORTADORA:**
- El rango de **VELOCIDAD NORMAL** es de entre 2 y 5 millas por hora.
- **AJUSTE LA VELOCIDAD DE CORTE** según las condiciones del terreno y el tipo de césped, la densidad y la altura del corte.
- **REDUZCA LA VELOCIDAD DE CORTE** al acercarse a inclinaciones empinadas, pozos, desniveles, obstrucciones elevadas, cables de alimentación y para evitar residuos y objetos extraños.

INFESTACIÓN CON INSECTOS

- No opere en áreas susceptibles al ataque de abejas o insectos, salvo que **USE PRENDAS PROTECTORAS** o una cabina de tractor cerrada.

VELOCIDAD DE PTO:

- **NO EXCEDA LA VELOCIDAD DE PTO NOMINAL DEL IMPLEMENTO**
- **EVITE** superar las velocidades nominales de PTO, porque puede causar roturas en la línea de conducción o fallas de las cuchillas.
- **SENALES DE SEGURIDAD:**
- **REEMPLACE** cualquier señal de seguridad faltante, dañada o ilegible. *PN OS01 SP*

SEGURIDAD

SEGURIDAD

INSTRUCCIONES DE SEGURIDAD Y PRÁCTICAS GENERALES

El mejor operador es un operador cuidadoso. La seguridad es de importancia fundamental para el fabricante, y también debería serlo para el propietario u operador. La mayoría de los accidentes se pueden evitar prestando suma atención al equipo, al ambiente circundante, y tomando algunas precauciones. La primera sección de este manual incluye una lista de Mensajes de Seguridad que deben observarse para contribuir a la protección del operador y otras personas frente a lesiones o la muerte. Lea con atención estos Mensajes de Seguridad antes de ensamblar, operar o reparar este implemento. Este equipo sólo debe ser operado por personas que hayan leído el manual, responsables y calificadas, que sepan cómo hacerlo de manera responsable.



El Símbolo de Alerta de Seguridad se utiliza en combinación con una Señal Verbal, tal como la que se muestra a continuación, en todo este manual y en los autoadhesivos adheridos a los equipos. El Símbolo de Alerta de Seguridad significa:

“¡ATENCIÓN! MANTÉNGASE ALERTA! SU SEGURIDAD ESTÁ EN JUEGO!” El Símbolo y la Señal Verbal tienen el objetivo de advertir al propietario/operador sobre un riesgo inminente y el grado de lesión que se puede producir al operar este equipo.

Adopte todas las medidas habituales para trabajar en forma segura y, sobre todo, recuerde que la seguridad depende de USTED. Sólo USTED puede impedir una lesión grave o la muerte a causa de prácticas no seguras.



Indica una situación peligrosa inminente que, de no ser evitada, OCASIONARÁ la MUERTE O UNA LESIÓN MUY GRAVE.



Indica una situación peligrosa inminente que, de no ser evitada, PODRÍA OCASIONAR la MUERTE O UNA LESIÓN MUY GRAVE.



Indica una situación peligrosa inminente que, de no ser evitada, PODRÍA OCASIONAR UNA LESIÓN MENOR.

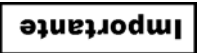

Indica instrucciones o procedimientos específicos que, de no observarse estrictamente, podrían ocasionar daños o la destrucción de la maquinaria, los accesorios o el entorno.

NOTA: Identifica aspectos de particular interés para lograr una operación o reparación más eficiente y conveniente.

LEA CON ATENCIÓN Y RESPETE los siguientes Mensajes de Seguridad. Si no se siguen cuidadosamente las advertencias e instrucciones indicadas en este Manual y en los Mensajes de Seguridad del implemento, se pueden producir lesiones graves o la muerte. Siempre siga las instrucciones de este manual y use el sentido común para evitar situaciones peligrosas.



Los pictogramas se utilizan a lo largo de este manual para ayudar a que su atención visual se centre en los problemas de seguridad.

PREVENCIÓN DE SEGURIDAD	PROCEDIMIENTO DE EVITACIÓN	PELIGRO DE SEGURIDAD
<p>No FUMAR</p> <p>EJEMPLO: Una acción que está prohibida.</p>	<p>EJEMPLO: lesiones</p> <p>evitación que se debe seguir para evitar una caja indica un procedimiento de</p> <p>El pictograma por sí mismo o dentro de</p> <p>Apague siempre el motor y retire la llave antes de trabajar en el equipo</p>	<p>EJEMPLO: evitar.</p> <p>Indica un peligro de seguridad que debe</p> <p>El pictograma rodeado por un triángulo</p> <p>Equipos en contacto con líneas eléctricas aéreas</p>

NOTA: Si desea obtener una traducción de esta sección de seguridad en alguno de los siguientes idiomas, comuníquese con: Translations, a la dirección 1502 E. Walnut Street Seguin, TX 78155; Fax: (830) 372-9529; La Sección de Seguridad está disponible en español, portugués, francés, alemán, ruso. PN 6501 SP

SECCIÓN DE SEGURIDAD

Sección de Seguridad 1-1

Instrucciones de operaciones antes de la entrega del DISTRIBUIDOR al CLIENTE

El distribuidor deberá informar al comprador de este producto las condiciones, disposiciones y procedimientos de garantía aplicables; informar la responsabilidad del comprador de capacitar a sus operadores para la operación segura; revisar el contenido del Manual del Operador, incluido el equipo de seguridad, la operación segura y el mantenimiento; y revisar las Señales de Seguridad que se encuentran en el implemento (y en el tractor, de ser posible).

- **IMPLEMENTOS:** He explicado que los deflectores, protectores de cadena o faldones sólidos se deben mantener en buenas condiciones de reparación y se deben instalar, excepto en zonas donde personas, vehículos, ganado u otros bienes no corran peligro por objetos arrojados, y en los casos en que dichos equipos de seguridad impedirían un desempeño razonable de la cortadora en su tarea asignada.
- **LÍNEAS DE CONDUCCIÓN:** Me he asegurado de que todos los protectores de líneas de conducción, de caja de engranajes y otros están en buenas condiciones de reparación y firmemente sujetos para prevenir lesiones por entredos u objetos arrojados.

- **MÁQUINAS HIDRÁULICAS:** He explicado la necesidad de usar aceite hidráulico limpio, cambiar los filtros según las instrucciones, detener filtraciones, prevenir daños por operar con aceite demasado caliente, cuidar las mangueras, usar mangueras del tipo correcto, mantener la presión operativa especificada y prevenir el posible riesgo de que el aceite penetre en la piel.

- **IMPLEMENTOS PLEGABLES:** He explicado que no es posible proteger contra objetos arrojados cuando el cabezal está elevado del suelo y que el operador es responsable de verificar que no existan personas en las inmediaciones. He explicado que el brazo o cabezal de cortadora elevado puede entrar en contacto con obstrucciones elevadas y dañar cables y líneas telefónicas, y posiblemente causar lesiones. He explicado que el brazo o cabezal extendido, o el brazo, puede entrar en contacto con cables de alimentación y causar lesiones o la muerte por electrocución, y que el operador es responsable de evitar dichos riesgos.

SERVICIO ANTES DE LA ENTREGA VERIFIQUE Y AJUSTE O LUBRIQUE SEGUN SEA NECESARIO

Consulte los detalles en el Manual del Operador
Inspección realizada – Garantía y procedimientos de seguridad explicados – Instalación realizada

LUBRICACIÓN E HIDRÁULICA

- Caja de engranajes (niveles de aceite)
- Nivel de aceite hidráulico (tanque externo)
- Nivel de aceite hidráulico del tractor
- Mangueras hidráulicas (no retorcidas y ajustadas)
- Propulsor de bomba frontal (conjunto ajustado y eje bien alineado)

CORTADORA

- Nivel y altura de corte de la cortadora ajustados
- Cojinetes del eje de corte lubricados
- Todas las piezas metálicas bien ajustadas

ACCESORIOS E INSTALACIÓN

- Deflectores frontales y traseros
- Sentido de giro de las hojas correcto

CONEXIONES DE CORTADORA A TRACTOR

- Pivote y conexiones de bastidor en A
- Altura de eje (ajustar)
- Altura de corte (ajustar)
- Verificación de pre-operación de kit de montaje

ELEMENTOS DE SEGURIDAD

- Protectores (operación e instalación)
- Embrague de línea de conducción (limitador de ajuste) (ajustar y poner en marcha)
- Autoadhesivos de seguridad (colocados)
- Manual del Operador (entregado)
- Protector de TDF del tractor (instalado)
- Emblema S.M.V. (instalado de ser necesario)
- Gato con lengüeta (instalación y operación)
- Cadena de remolque de seguridad (instalada)
- Manual de Seguridad de Línea de Conducción ADMA (entregado)
- Manual de Seguridad de Cortadora AEM (entregado en porta manual)
- Se mostró el Video de Seguridad de Cortadora AEM al comprador

Alamo Industrial está dispuesto a suministrar un (1) Video de Prácticas de Seguridad para Cortadoras AEM

Por favor enviar: Video de Seguridad para el Operador de Cortadoras AEM/FEMA – formato VHS

Video de Seguridad para el Operador de Cortadoras AEM/FEMA – formato DVD

Manual del Operador de la Cortadora

Manual de Seguridad del Operador de la Cortadora AEM

Nombre del solicitante: _____ Teléfono: _____

Dirección del solicitante: _____

Ciudad _____

Estado _____

Código postal _____

Modelo de cortadora: _____ Número de serie: _____

Fecha de compra: _____ Vendedor del distribuidor: _____

Nombre del distribuidor: _____ Dirección del distribuidor: _____

Enviar por correo a:

AEM Video Services

1502 E. Walnut Street

Seguin, TX 78155

enviar por fax a:

(830) 372-9529

enviar por correo electrónico a:

AEMVideo@alamo-group.com



➤ **Sea Seguro**

➤ **Sea Alerto**

➤ **Sea Vivo**

➤ **Sea Entrenado**

**antes de funcionar
el cortacésped**

Entrenamiento de Seguridad Hace la Diferencia

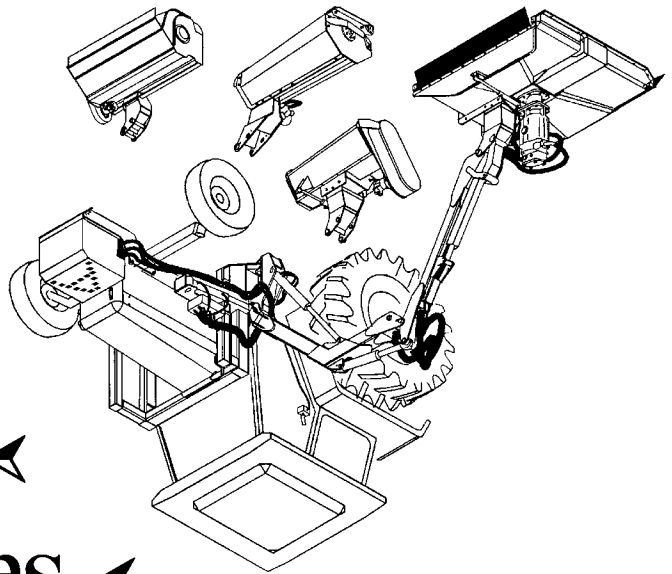

A fin de reducir la tasa de accidentes y mejorar la operación segura de las cortadoras, Alamo Industrial se ha asociado con otros fabricantes de la industria para desarrollar el video y la guía de Prácticas de Seguridad para Cortadoras Industriales y Agrícolas AEM/FEMA.

El video explica a los operadores de tractores y cortadoras las prácticas seguras que deben adoptar cuando utilizan cortadoras industriales y agrícolas. Es importante que todos los operadores de cortadoras aprendan cómo operar sus equipos de corte y puedan reconocer los posibles peligros que pueden surgir al operar una cortadora. Este video, en conjunto con el manual del operador de la cortadora y los mensajes de advertencia que se encuentran en la cortadora, serán muy útiles para complementar este aprendizaje tan importante.

Es posible que su distribuidor autorizado de *Alamo Industrial* le haya mostrado este video y le haya entregado una copia en DVD cuando adquirió su cortadora. Si usted o algún operador de cortadora no vio el video: mire el video, lea este Manual del Operador, y complete la Guía del Video antes de operar su cortadora nueva. Si no comprende alguna de las instrucciones del video o del manual del operador, o si tiene alguna pregunta acerca de la operación segura, comuníquese con su supervisor, con el distribuidor o con Alamo Industrial. Si desea recibir una copia del video en VHS, envíe un mensaje de correo electrónico a AEMVideo@alamo-group.com o un fax al (830) 372-9529, o envíe por correo una copia rellena del formulario que se encuentra al dorso de esta página a AEM VHS Video 1502 E Walnut Street, Seguin, TX 78155, y solicite la versión en VHS. Indique su nombre, dirección postal, modelo de cortadora y número de serie.

Cada uno de los operadores debe recibir capacitación para cada equipo (tractor y cortadora), comprender el uso previsto, y comprender los posibles peligros antes de operar el equipo. La información y material mecionado en la información anterior junto con el Manual de Operador puede asistir en cumplir con los requisitos de OSHA para el entrenamiento anual del Operador.

REQUISITOS DE ENTRENAMIENTO DEL OSHA

Los siguientes requisitos de entrenamiento se an tomada del Título 29, código de la pieza de regulaciones federales 1928.57 (a) (6). www.osha.gov

Instrucciones del operador. A la hora de la asignación inicial y por lo menos anualmente después de eso, el empleador mandará a cada empleado quien opera un tractor agrícola o implemento en las prácticas de operación segura y el mantenimiento de el equipo con el cual el empleado este, o estará implicado y de cualquier otras prácticas dictados por el ambiente laboral.

Al propietario/operador/distribuidor

Este Manual del Operador es una parte esencial de la operación segura de esta máquina y se debe mantener con la unidad siempre. El implemento incluye un porta manual donde se puede guardar el manual de manera adecuada. Si el manual se extravía o se daña, puede solicitar otra copia sin cargo a un distribuidor autorizado de *Alamo Industrial* o descargarlo del sitio web de *Alamo Industrial* (www.alamo-industrial.com).

ANTES DE COMENZAR LEA, COMPRENDA Y SIGA la información incluida en este manual, el Manual de Seguridad de la Cortadora AEM y el manual del operador del tractor para conocer cómo operar la máquina y realizar tareas de servicio correctamente. De lo contrario, podría sufrir lesiones u ocasionar lesiones a terceros. Todos los implementos con partes móviles son potencialmente peligrosos. Cada esfuerzo ha sido hecho para asegurar que la máquina esté segura, pero los operadores deben evitar entrar en prácticas peligrosas y seguir las instrucciones escritas que son proporcionadas. El fabricante ha diseñado este implemento para ser usado con todos sus equipos de seguridad correctamente sujetados para minimizar la probabilidad de accidentes.

LA SEGURIDAD PRIMERO. Lea con atención la totalidad de la sección de seguridad de este manual antes de operar el equipo. No permita que nadie opere el equipo sin haber leído y comprendido la totalidad de este manual. Comuníquese con el distribuidor si necesita explicación sobre alguna instrucción que no haya comprendido del todo.

Los cuidados que brinde a su implemento *Alamo Industrial* determinarán en gran medida su satisfacción con el desempeño y la vida útil del equipo. Lea con atención y siga las instrucciones de este manual para comprender cabalmente su nuevo implemento, su uso previsto, y sus requisitos de servicio.

Todas las referencias que se hacen en este manual a derecha, izquierda, frontal, trasero, arriba y abajo corresponden a la perspectiva en el sentido del desplazamiento hacia delante con el implemento correctamente sujetado al tractor.

La información sobre repuestos se encuentra por separado en el Manual de Partes. Las cortadoras *Alamo Industrial* utilizan componentes del sistema equilibrados y coincidentes para porta cuchillas, cuchillas, ejes de corte, hojas, ganchos para hojas, rodillos, componentes de los engranajes, y cojinetes. Estas partes se fabrican y se prueban según las especificaciones de *Alamo Industrial*. Las partes compatibles no genuinas no siempre cumplen con estas especificaciones. El uso de partes no genuinas puede perjudicar el desempeño de la cortadora, anular la garantía y presentar un riesgo para la seguridad. Use partes genuinas *Alamo Industrial* para ahorrar dinero y maximizar la seguridad.

Para referencia futura, registre el número de modelo y el número de serie de *Alamo Industrial* que ha adquirido.

Distribuidor	Teléfono	Número de Modelo
Dueño	Fecha de compra:	Número de serie



INTERSTATER

Segadora Desgranadora



Publicado en 10/18

MANUAL DE OPERADOR

Parte n°. 803213C

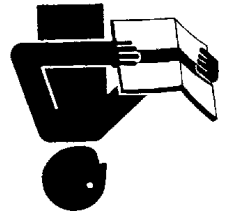

Este Manual del Operador es una parte esencial de la operación segura de esta máquina y se debe mantener con la unidad siempre. LEA, ENTENDA, y SIGA las Instrucciones de Seguridad y Operación contenidas en este manual antes de operar el equipo. C01-Cover SP_A

Importantes instrucciones de operación y las instrucciones de seguridad se encuentran en el video Cortacésped Sobre Seguridad que se puede acceder instantáneamente en el internet en: www.aligr.com/avs



www.aligr.com/avs



FCP-FL-0004

ALAMO INDUSTRIAL®

1502 E. Walnut
Seguin, Texas 78155
830-372-3551

Email: parts@alamo-industrial.com

Página Web de
Alamo Industrial

www.aligr.com/avs

ATTENTION!
Read Manual

If you do not read
spanish
please flip manual over in
english.

**MEMBER OF THE
ALAMO GROUP**

ALWAYS ON THE CUTTING EDGE®

©2018 Alamo Group Inc.

\$0.00